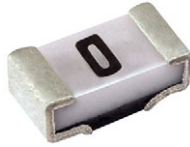


Zero Ohm Jumper (0.003 Ω Max.), Metal Foil, Surface-Mount Device


FEATURES

- Ideal for all applications including switching power supplies, voltage regulation modules, DC/DC converters and power management applications
- AEC-Q200 qualified
- High current jumper
- Material categorization: for definitions of compliance please see www.vishay.com/doc?99912



RoHS
COMPLIANT
HALOGEN
FREE

STANDARD ELECTRICAL SPECIFICATIONS

GLOBAL MODEL	SIZE	CURRENT RATING A	WEIGHT (typical) g/1000 pieces	RESISTANCE VALUE MAX. Ω
WFZ0402	0402	6.5	0.86	0.003
WFZ0603	0603	25	3.28	0.0005
WFZ0805	0805	31	7.86	0.0005
WFZ1206	1206	38	14.44	0.0005
WFZ2512	2512	63	57.89	0.0005

Note

- AEC-Q200 rev. E testing

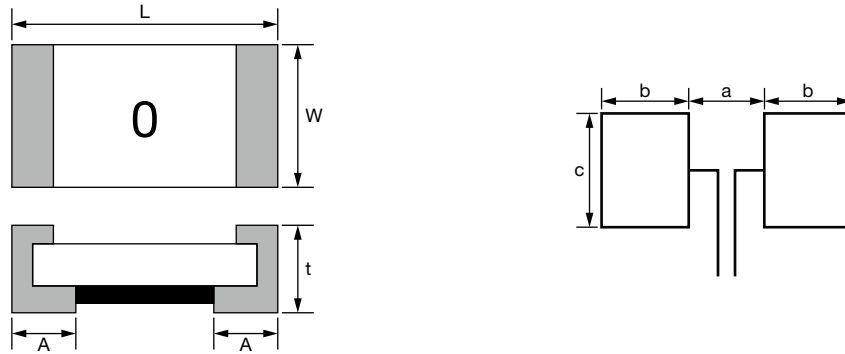
GLOBAL PART NUMBER INFORMATION

Global Part Numbering Example: WFZ080500000Z E66

W	F	Z	0	8	0	5	0	0	0	0	0	Z	E	6	6		
GLOBAL MODEL (3 digits) WFZ			CASE SIZE (EIA) (4 digits) 0805				RESISTANCE VALUE (5 digits) 00000 = jumper					TOLERANCE CODE (1 digit) Z = jumper			PACKAGING CODE (3 digits) E66 = lead (Pb)-free, tape/reel		

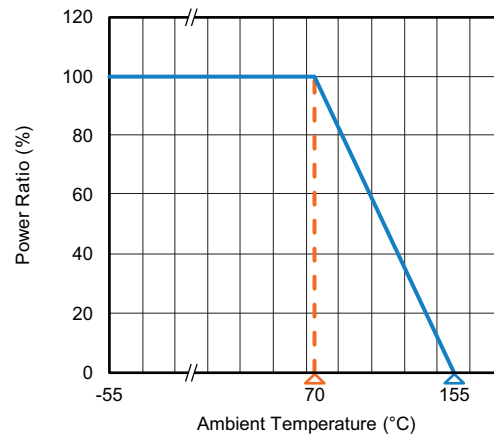
TECHNICAL SPECIFICATIONS

PARAMETER	UNIT	RESISTOR CHARACTERISTICS
Operating temperature range	°C	-55 to +155

DIMENSIONS in millimeters

Note

- Surface mount solder profile recommendations: www.vishay.com/doc?31052

TYPE (INCH SIZE)	DIMENSIONS (in millimeters)				SOLDER PAD DIMENSIONS (in millimeters)		
	L	W	t	A	a	b	c
WFZ0402	1.00 ± 0.10	0.50 ± 0.10	0.40 ± 0.10	0.30 ± 0.10	0.40	0.50	0.60
WFZ0603	1.55 ± 0.10	0.80 ± 0.10	0.55 ± 0.10	0.35 ± 0.20	0.90	0.70	1.00
WFZ0805	2.00 ± 0.15	1.25 ± 0.15	0.65 ± 0.10	0.35 ± 0.20	1.20	1.20	1.40
WFZ1206	3.10 ± 0.20	1.55 ± 0.15	0.70 ± 0.10	0.80 ± 0.20	2.00	1.30	1.80
WFZ2512	6.35 ± 0.20	3.10 ± 0.20	0.65 ± 0.10	0.80 ± 0.25	3.80	2.10	3.40

DERATING




PERFORMANCES			
DESCRIPTION	AEC TEST NUMBER	TEST CONDITIONS	LIMIT
High temperature exposure (storage)	3	MIL-STD-202, Method 108, 1000 h at T = 155 °C at 0 % power, measurements at 24 h ± 4 h	0402: ≤ 3 mΩ 0603 to 2512: ≤ 500 μΩ
Temperature cycling	4	JESD22 Method JA-104; 1000 cycles (-55 °C to +155 °C) measurement at 24 h ± 4 h after test conclusion. 15 min. dwell time at each temperature extreme. 1 min. maximum transition time.	0402: ≤ 3 mΩ 0603 to 2512: ≤ 500 μΩ
Moisture resistance	6	MIL-STD-202, Method 106, t = 24 h/cycle. Note: steps 7a and 7b not required, 0 % power, no polo, 65 °C, Measurement at 24 h ± 2 h after test.	0402: ≤ 3 mΩ 0603 to 2512: ≤ 500 μΩ
Biased humidity	7	MIL-STD-202, Method 103, 1000 h 85 °C/85 % RH. Note: specified conditions: 10 % of rating current. Measurement at 24 h ± 4 h after test.	0402: ≤ 3 mΩ 0603 to 2512: ≤ 500 μΩ
Operational life	8	MIL-STD-202 Method 108; 1000 h test; Condition D; 1.5 h "ON", 0.5 h "OFF"; +70 °C at rated current. Measurement 24 h ± 4 h after test conclusion	0402: ≤ 3 mΩ 0603 to 2512: ≤ 500 μΩ
External visual	9	MIL-STD-883, Method 2009; electrical test not required. Inspect device construction, marking, and workmanship	Per MIL-STD-883
Physical dimension	10	JESD22 Method JB-100, Verify physical dimensions to the standard WFZ datasheet.	Per datasheet
Resistance to solvents ⁽¹⁾	12	MIL-STD-202 Method 215; Note: add aqueous wash chemical - OKEM clean or equivalent.	Marking remains legible
Mechanical shock	13	MIL-STD-202, Method 213, Condition C	0402: ≤ 3 mΩ 0603 to 2512: ≤ 500 μΩ
Vibration	14	MIL-STD-202 Method 204; 5 g's for 20 min., 12 cycles each of 3 orientations. Test from 10 Hz to 2000 Hz. Verify transfer load using a laser vibrometer or other adequate measuring device.	0402: ≤ 3 mΩ 0603 to 2512: ≤ 500 μΩ
Resistance to solder heat	15	MIL-STD-202, Method 210, condition K	0402: ≤ 3 mΩ 0603 to 2512: ≤ 500 μΩ
ESD	17	AEC-Q200-002	0402: ≤ 3 mΩ 0603 to 2512: ≤ 500 μΩ
Solderability	18.1	J-STD-002; Method B1; 4 h at +155 °C dry heat; +235 °C lead (Pb)-free; no electrical test; 50 x mag.	> 95 % coverage
Solderability	18.2	J-STD-002; Method B; 4 h at +155 °C dry heat; +215 °C SnPb; no electrical test; 50 x mag.	> 95 % coverage
Solderability	18.3	J-STD-002; Method D; 4 h at +155 °C dry heat; +260 °C lead (Pb)-free; no electrical test; 50 x mag.	> 95 % coverage
Electrical characterization	19	⁽²⁾	
Flammability	20	UL 94	V-0
Board flex	21	AEC-Q200-005; 2 mm min, 60 s hold time	0402: ≤ 3 mΩ 0603 to 2512: ≤ 500 μΩ
Terminal strength (SMD)	22	0402: AEC-Q200-006 force of 0.75 kg for 60 s (terminal strength force was adjusted to 0.75 kg to test to MIL-PRF-55342 Table XVI.) 0603 to 2512: AEC-Q200-006 force of 1.8 kg for 60 s	0402: ≤ 3 mΩ 0603 to 2512: ≤ 500 μΩ
Short time overload		MIL-PRF-55342 paragraph 4.8.6: 2.5 x rated current for 5 s.	0402: ≤ 3 mΩ 0603 to 2512: ≤ 500 μΩ

Notes

- Full qualification data available upon request at ww2bresistors@vishay.com

⁽¹⁾ Applies to all case sizes except 0402, which does not contain marking

⁽²⁾ Electrical characterization was not performed for this part, as this is a zero-ohm jumper, and not a resistor. The TCR for Cu = 3900 ppm/°C

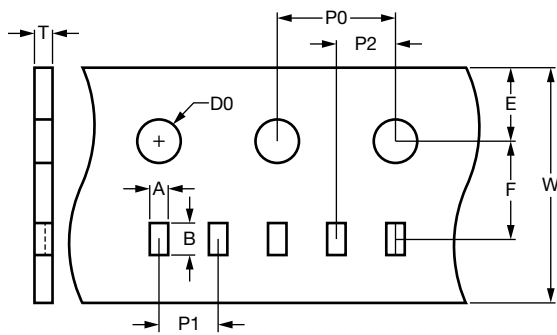
TAPE SPECIFICATION


Fig. 1

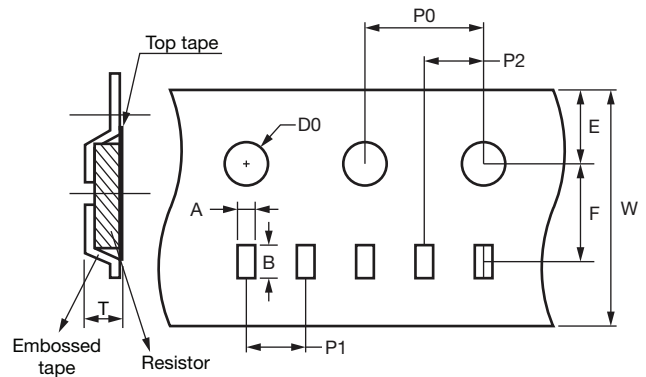


Fig. 2

TYPE	CARRIER DIMENSIONS in millimeters										
	A	B	E	F	W	P0	P1	P2	D0	T	FIG.
WFZ0402	0.7 ± 0.05	1.2 ± 0.05	1.75 ± 0.1	3.5 ± 0.05	8.0 ± 0.2	4.0 ± 0.1	2.0 ± 0.1	2.0 ± 0.05	1.55 ± 0.05	0.45 ± 0.1	1
WFZ0603	1.1 ± 0.1	1.9 ± 0.1	1.75 ± 0.1	3.5 ± 0.05	8.0 ± 0.2	4.0 ± 0.1	4.0 ± 0.1	2.0 ± 0.05	1.55 ± 0.05	0.60 ± 0.1	1
WFZ0805	1.6 ± 0.1	2.4 ± 0.1	1.75 ± 0.1	3.5 ± 0.05	8.0 ± 0.2	4.0 ± 0.1	4.0 ± 0.1	2.0 ± 0.05	1.55 ± 0.05	0.97 ± 0.1	1
WFZ1206	2.0 ± 0.1	3.6 ± 0.1	1.75 ± 0.1	3.5 ± 0.05	8.0 ± 0.2	4.0 ± 0.1	4.0 ± 0.1	2.0 ± 0.05	1.55 ± 0.05	0.97 ± 0.1	1
WFZ2512	3.5 ± 0.1	6.8 ± 0.1	1.75 ± 0.1	5.5 ± 0.05	12.0 ± 0.2	4.0 ± 0.05	4.0 ± 0.1	2.0 ± 0.05	1.5 ± 0.1	1.0 ± 0.2	2

PACKAGING			
MODEL	TAPE WIDTH	DIAMETER	PIECES / REEL
WFZ0402	Embossed paper tape	178 mm / 7"	10 000
WFZ0603 WFZ0508 WFZ1206	Embossed paper tape	178 mm / 7"	5000
WFZ2512	Embossed plastic tape	178 mm / 7"	4000



Disclaimer

ALL PRODUCT, PRODUCT SPECIFICATIONS AND DATA ARE SUBJECT TO CHANGE WITHOUT NOTICE TO IMPROVE RELIABILITY, FUNCTION OR DESIGN OR OTHERWISE.

Vishay Intertechnology, Inc., its affiliates, agents, and employees, and all persons acting on its or their behalf (collectively, "Vishay"), disclaim any and all liability for any errors, inaccuracies or incompleteness contained in any datasheet or in any other disclosure relating to any product.

Vishay makes no warranty, representation or guarantee regarding the suitability of the products for any particular purpose or the continuing production of any product. To the maximum extent permitted by applicable law, Vishay disclaims (i) any and all liability arising out of the application or use of any product, (ii) any and all liability, including without limitation special, consequential or incidental damages, and (iii) any and all implied warranties, including warranties of fitness for particular purpose, non-infringement and merchantability.

Statements regarding the suitability of products for certain types of applications are based on Vishay's knowledge of typical requirements that are often placed on Vishay products in generic applications. Such statements are not binding statements about the suitability of products for a particular application. It is the customer's responsibility to validate that a particular product with the properties described in the product specification is suitable for use in a particular application. Parameters provided in datasheets and / or specifications may vary in different applications and performance may vary over time. All operating parameters, including typical parameters, must be validated for each customer application by the customer's technical experts. Product specifications do not expand or otherwise modify Vishay's terms and conditions of purchase, including but not limited to the warranty expressed therein.

Hyperlinks included in this datasheet may direct users to third-party websites. These links are provided as a convenience and for informational purposes only. Inclusion of these hyperlinks does not constitute an endorsement or an approval by Vishay of any of the products, services or opinions of the corporation, organization or individual associated with the third-party website. Vishay disclaims any and all liability and bears no responsibility for the accuracy, legality or content of the third-party website or for that of subsequent links.

Vishay products are not designed for use in life-saving or life-sustaining applications or any application in which the failure of the Vishay product could result in personal injury or death unless specifically qualified in writing by Vishay. Customers using or selling Vishay products not expressly indicated for use in such applications do so at their own risk. Please contact authorized Vishay personnel to obtain written terms and conditions regarding products designed for such applications.

No license, express or implied, by estoppel or otherwise, to any intellectual property rights is granted by this document or by any conduct of Vishay. Product names and markings noted herein may be trademarks of their respective owners.