

Data Sheet | Item Number: 890-855
Plug for PCBs; straight; 5-pole; Cod. B; gray

<https://www.wago.com/890-855>

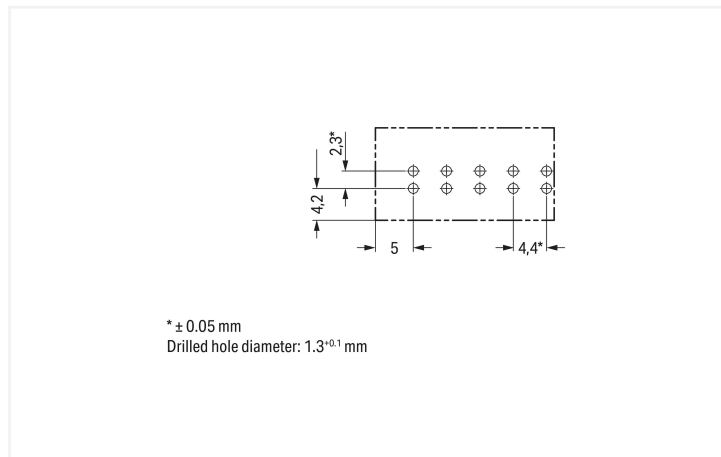

Color: ■ gray

Dimensions in mm

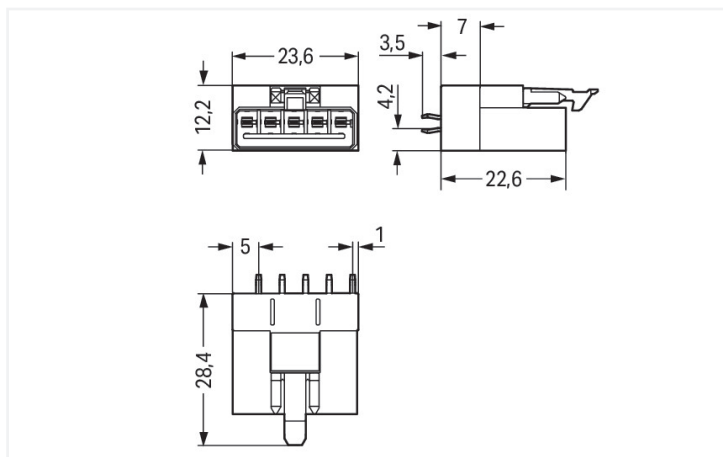

Dimensions in mm

Male connector/plug WINSTA® MINI rated current 16 A

The WINSTA® MINI male connector/plug with protection against mismatching offers very secure handling to support drive and control technology tasks. The pluggable PCB connectors with spring pressure connection technology and Push-in CAGE CLAMP® technology from WAGO allow impact-resistant, maintenance-free, fast terminal connections. The mechanical coding and color coding of the pcb connectors ensure error-free installation of the individual components – including protection against mismatching. Solutions like the WINSTA® MINI pcb connectors with B coding are suitable for process control, such as for lighting or in data networks. Particularly if only limited space is available, our smallest pluggable connection system, WINSTA® MINI, conveniently displays its advantageous properties. It is very compact, and, with Push-in CAGE CLAMP® spring pressure connection technology, it additionally saves time, since the connection is low-maintenance and can be performed without screw connections.

WINSTA® MINI solutions for your electrical installation – protected against mismatching and maintenance-free

WINSTA® is the pluggable connection system that is optimally tailored to the strict requirements of electrical installation. It offers error-free installation of cables and components, quickly and reliably. Choose quality and durability – with locking lever from WAGO makes the electrical installation of electrical components noticeably easier.

- protection against mismatching eliminates errors
- consistent IP40 protection
- with B coding for use in automation of processes, such as lighting technology, for example
- quick replacement of defective units during ongoing operation

Notes

General safety information

1. Only to be used by a qualified electrician or by a person electrically instructed for the task (EIP per DIN VDE 0105-100).
2. Do not install while energized or under load.
3. Use only for its intended purpose.
4. Observe applicable national regulations, standards and directives.
5. Observe the technical specifications of the products.
6. Ensure correct polarity assignment.
7. Do not use damaged or contaminated components.
8. Observe conductor types, conductor cross-sections, strip lengths and cable diameters.
9. Insert conductors up to the stop.
10. Use only with locking lever and strain relief.
11. Use original accessories only.

To be sold only with installation instructions!

Variants:

Other pole markings

Other versions (or variants) can be requested from WAGO Sales or configured at <https://configurator.wago.com/>.

Electrical data

Ratings per	IEC/EN 60664-1		
Overvoltage category	III	III	II
Pollution degree	3	2	2
Nominal voltage	250 V	-	-
Rated impulse withstand voltage	4 kV	-	-
Rated current	16 A	-	-

Ratings per IEC/EN – Notes

Rated current (note)	13 A for 3-pole load 10 A for 4- and 5-pole load
----------------------	---

Approvals per

UL 1977

Rated voltage	600 V
Rated current	12 A

General information

Note on contact resistance	approx. 1 mΩ of contact resistance approx. 0.25 mΩ contact transition plug/socket
----------------------------	--

Connection Data

Total number of potentials	5
----------------------------	---

Connection 1

Pole number	5
-------------	---

Physical data

Pin spacing	4.4 mm / 0.173 inches
Width	23.6 mm / 0.929 inches
Height	31.9 mm / 1.256 inches
Height from the surface	28.4 mm / 1.118 inches
Depth	12.2 mm / 0.48 inches
Solder pin length	3.5 mm
Solder pin dimensions	1 x 0.8 mm
Drilled hole diameter	1.3 ^(+0.1) mm

Mechanical data

Use	Control technology
Coding	B
Variable coding	No
Marking	5 4 3 2 1
Potential marking	5 4 3 2 1
Mating force of a plug-in connection	approx. 20 ... 70 N (depending on pole number)
Retention force of a plug-in connection	Locked: > 80 N
Unmating force of a plug-in connection	Unlocked: approx. 20 ... 70 N (depending on pole number)
Number of mating cycles	200, without resistive load 100, with resistive load $I_N = 16$ A, tested (1.5 mm ²)
Design	straight

Plug-in connection

Contact type (pluggable connector)	Male connector/plug
Connector (connection type)	for PCB
Mismating protection	Yes
Note on mismating protection	All WINSTA® components are 100% protected against mismating when: a.) plugging different numbers of poles b.) plugging while rotated 180 c.) plugging while laterally staggered d.) plugging one pole
Mating direction to the PCB	90 °
Locking lever	Yes
Locking of plug-in connection	Locking lever
Note on locking system	All connectors for mounted installations (snap-in versions for lighting fixtures or devices, all types of PCB and distribution connectors) are factory-equipped with locking levers to ensure plugs and sockets are securely locked. Additional locking levers are only required for flying leads (plug/socket).

PCB contact

PCB contact	THT
Solder pin arrangement	2 in-line solder pins/pole
Number of solder pins per potential	2

Material data

Note (material data)	Information on material specifications can be found here
Color	gray
Cover color	gray
Material group	I
Insulation material (main housing)	Polyamide (PA66)
Flammability class per UL94	V0
Clamping spring material	Chrome-nickel spring steel (CrNi)
Contact material	Copper or copper alloy; surface-treated
Contact Plating	Tin
Fire load	0.075 MJ
Weight	4.8 g

Environmental requirements

Processing temperature	-5 ... +40 °C
Continuous operating temperature	-35 ... +85 °C
Note on continuous operating temperature	Insulating parts for temperatures ≤ 105 °C

Commercial data

PU (SPU)	50 pcs
Packaging type	Box
Country of origin	PL
GTIN	4050821890010
Customs tariff number	85366990990

Product Classification

UNSPSC	39121409
eCl@ss 10.0	27-44-06-05
eCl@ss 9.0	27-44-06-05
ETIM 9.0	EC002637
ETIM 10.0	EC002637
ECCN	NO US CLASSIFICATION

Environmental Product Compliance

RoHS Compliance Status	Compliant, No Exemption
------------------------	-------------------------

Approvals / Certificates

General approvals



Approval	Standard	Certificate Name
CB DEKRA Certification B.V.	IEC 61984	NL-64351
CB DEKRA Certification B.V.	EN 61984	71-112993
cURus Underwriters Laboratories Inc.	UL 1977	E45171
KEMA/KEUR DEKRA Certification B.V.	EN 60320	2148952.04

Declarations of conformity and manufacturer's declarations

Approval	Standard	Certificate Name
EU-Declaration of Confor- mity WAGO GmbH & Co. KG	-	-
UK-Declaration of Confor- mity WAGO GmbH & Co. KG	-	-

Approvals for marine applications



Approval	Standard	Certificate Name
DNV GL Det Norske Veritas, Ger- manischer Lloyd	-	TAE00001Z6
LR Lloyds Register	EN 61535	LR23317167TA
PRS Polski Rejestr Statków	-	TE/1096/880590/23

Downloads

Environmental Product Compliance

Compliance Search

Environmental Product
Compliance 890-855



CAD/CAE-Data

CAD data

2D/3D Models 890-855



CAE data

ZUKEN Portal 890-855

