

TABLE 4	
POSITIONS	COPLANARITY
02 THRU 29	.004[0.10]
30 THRU 50	.006[0.15]

DO NOT SCALE FROM THIS PRINT

TABLE 1				
LEAD STYLE	"A"	"B"	AUTOMATED BKT	HAND FILL
-02	.075 [1.91] \odot	.075[1.91]	T-1S16-03-XX-2	T-1S16-01-XX-2
-03	.065 [1.65] \odot	.055[1.40]	T-1S16-04-XX-2	T-1S16-01-XX-2

FTMH-1XX-XX-XX-DV-XX-X-XX

No OF POS PER ROW
-02 THRU -50
(SEE NOTE 10)

LEAD STYLE

-02: .075 [1.91]
(USE T-1S16-03-XX-2)
-03: .065 [1.65]
(USE T-1S16-04-XX-2)

PLATING SPECIFICATION

-L: 10 μ " LIGHT SELECTIVE GOLD IN CONTACT AREA, MATTE TIN ON TAIL
-F: 3 μ " FLASH SELECTIVE GOLD IN CONTACT AREA, MATTE TIN ON TAIL
-H: 30 μ " HEAVY GOLD IN CONTACT AREA, 3 μ " FLASH GOLD ON TAIL
-G: 10 μ " GOLD IN CONTACT AREA, 3 μ " FLASH GOLD ON TAIL
-LM: 10 μ " LIGHT SELECTIVE GOLD IN CONTACT AREA, MATTE TIN ON TAIL
-FM: 3 μ " FLASH SELECTIVE GOLD IN CONTACT AREA, MATTE TIN ON TAIL

PACKAGING (SEE NOTE 5)
BLANK: TUBES (SEE NOTE 11)
-TR: TAPE & REEL (SEE NOTES 12 & 13)
-FR: FULL REEL QTY TAPE & REEL (SEE NOTES 12 & 13)

PICK & PLACE OPTION

-P: PICK & PLACE PAD (USE PPP-30)
(USE PPP-30-NT FOR TAPE & REEL)
(SEE FIG 3, SHT 4; 6 POS MIN)

OPTIONS

-ES: SNAP ON END SHROUDS (SEE FIG 2, SHT 2; 9 POS MIN)
MOLD TO POSITION END SHROUDS (5 POS MIN; SEE FIG 2, SHT 2)
(SAMTEC DISCRETION ON WHICH END SHROUDS ARE USED FOR POSITIONS -09 AND GREATER)
-EP: GUIDE POST (SEE FIG 4, SHT 4; 9 POS MIN)
(USE ONLY WHEN MATING WITH A CLM)
-EC: LOCKING CLIP (SEE FIG 5, SHT 4)
(SEE NOTE 9; 9 POS MIN)
-A: ALIGNMENT PIN (SEE FIG 6 & 7, SHT 5)
(SAMTEC DISCRETION ON WHICH -A PIN IS USED)
(MOLDED: 3 POS MIN, USE FTMH-75-D-XX)
(STAKED: 7 POS MIN, USE FTMH-60-D)

ROW SPECIFICATION

-DV: DOUBLE ROW VERTICAL (USE FTMH-75-D)

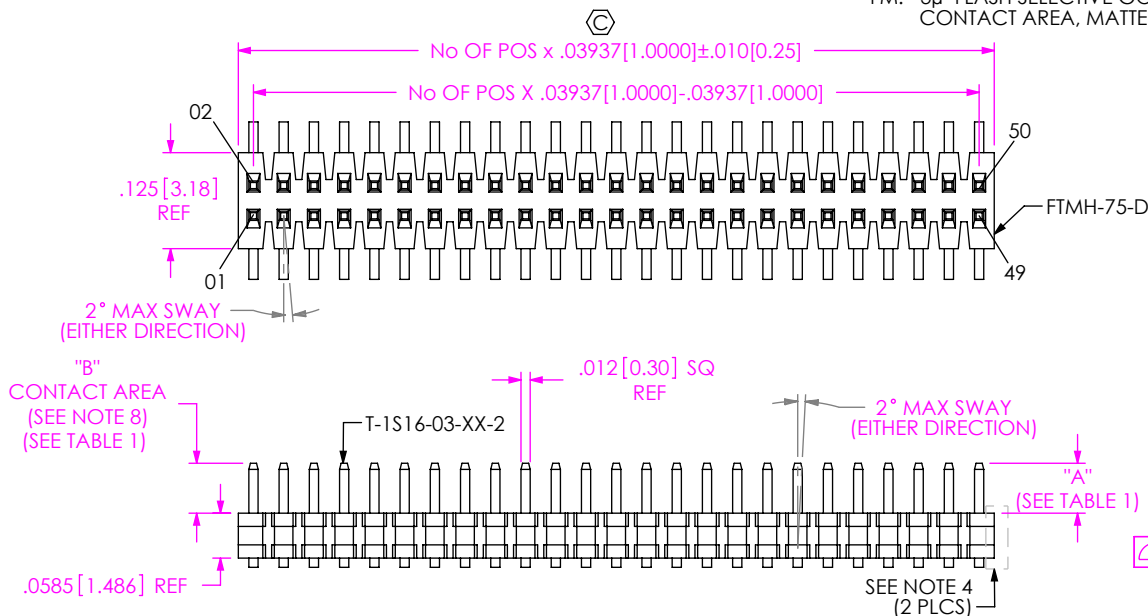
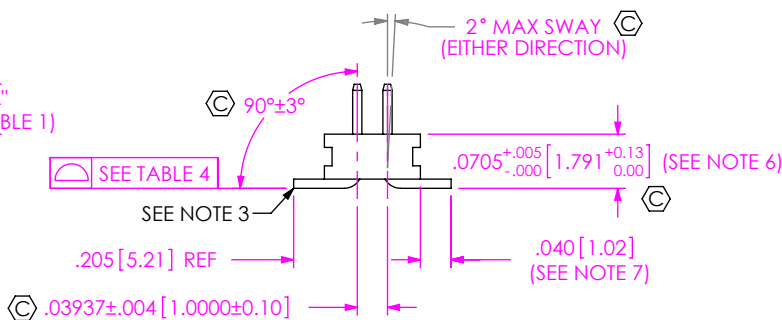

FIG 1
FTMH-125-03-X-DV SHOWN



NOTES:

- \odot REPRESENTS CRITICAL DIMENSION.
- MINIMUM PUSHOUT FORCE: 1.0 LB = 16 OZ.
- MAXIMUM BURR: .003 [0.08]
- MAXIMUM CUT FLASH: .010 [0.25]
- POSITIONS -02 THRU -04 TO BE LAYER PACKAGED.
- MEASURED AT BEND RADIUS.
- SHEAR TAILS TO DIMENSION SHOWN.
- FOR SELECTIVE PLATING OPTIONS, GOLD PLATING TO BE ON POST, TIN PLATING TO BE ON TAIL.
- DUE TO THE HIGH AMOUNT OF INSERTION FORCE NEEDED, THE -EC OPTION IS NOT COMPATIBLE WITH AUTO PLACEMENT. SAMTEC RECOMMENDS MANUAL PLACEMENT FOR ALL ASSEMBLIES WITH THE -EC OPTION.
- NUMBER OF POSITIONS MAY BE AS HIGH AS -75 FOR SAMTEC MANUFACTURING ONLY.
- TUBES ARE STANDARD PACKAGING.
- ORDERS WILL BE PACKAGED ACCORDING TO THE SAMTEC PACKAGING EFFICIENCY STANDARDS (SPES) FOUND ON WWW.SAMTEC.COM.
- ATTACH LABEL TO EACH REEL.
- ES MOLDED OPTION ONLY, DURING CUT PROCESS, WALL MUST BE A MINIMUM OF .004" OR COMPLETELY REMOVED.

UNLESS OTHERWISE SPECIFIED, DIMENSIONS ARE IN INCHES.

PROPRIETARY NOTE

THIS DOCUMENT CONTAINS CONFIDENTIAL AND PROPRIETARY INFORMATION AND ALL DESIGN, MANUFACTURING, REPRODUCTION, USE, PATENT RIGHTS AND SALES RIGHTS ARE EXPRESSLY RESERVED BY SAMTEC, INC. THIS DOCUMENT SHALL NOT BE DISCLOSED, IN WHOLE OR PART, TO ANY UNAUTHORIZED PERSON OR ENTITY NOR REPRODUCED, TRANSFERRED OR INCORPORATED IN ANY OTHER PROJECT IN ANY MANNER WITHOUT THE EXPRESS WRITTEN CONSENT OF SAMTEC, INC.

TOLERANCES ARE:

DECIMALS ANGLES
.XX: ±.01 [0.3]
.XXX: ±.005 [0.13]
.XXXX: ±.0020 [0.051]

MATERIAL DO NOT SCALE DRAWING SHEET SCALE: 5:1
INSULATOR: BLACK, LCP, UL-94-V-0
TERMINAL: PHOSPHOR BRONZE

DESCRIPTION:
1mm x 1mm DOUBLE VERTICAL SMT TERMINAL STRIP

DWG. NO.
FTMH-1XX-XX-XX-DV-XX-X-XX

BY: PURVIS 04/22/96 SHEET 1 OF 6

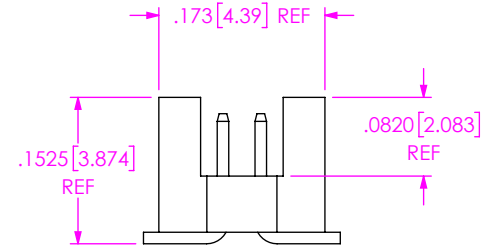
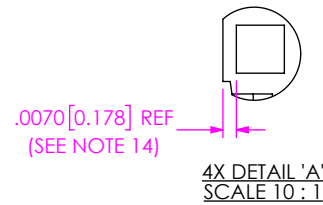
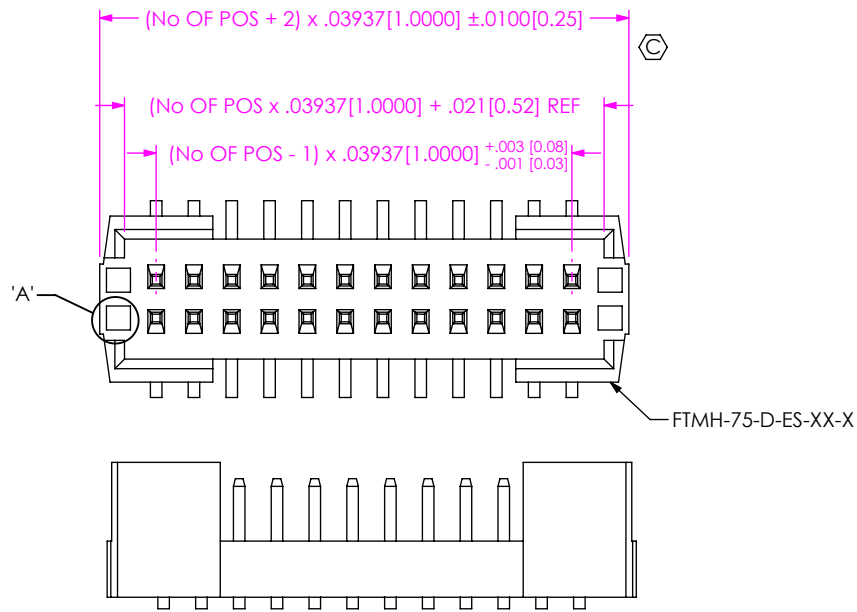
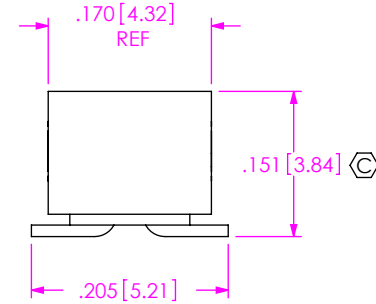
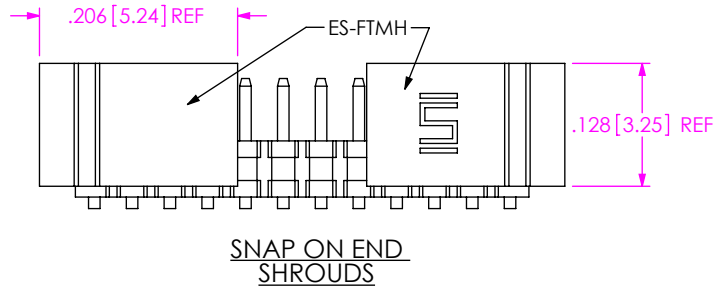
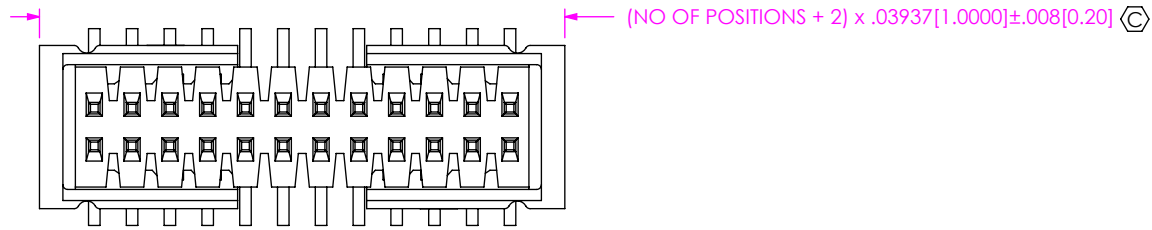

MOLDED TO POSITION END SHROUDS

FIG 2
-ES: END SHROUDS
FTMH-112-02-X-DV-ES SHOWN
(DIFFERENT AS SHOWN, OTHERWISE SAME AS FIG 1. MACHINE FILL ONLY)

PROPRIETARY NOTE
THIS DOCUMENT CONTAINS CONFIDENTIAL AND PROPRIETARY INFORMATION AND ALL DESIGN, MANUFACTURING, REPRODUCTION, USE, PATENT RIGHTS AND SALES RIGHTS ARE EXPRESSLY RESERVED BY SAMTEC, INC. THIS DOCUMENT SHALL NOT BE DISCLOSED, IN WHOLE OR PART, TO ANY UNAUTHORIZED PERSON OR ENTITY NOR REPRODUCED, TRANSFERRED OR INCORPORATED IN ANY OTHER PROJECT IN ANY MANNER WITHOUT THE EXPRESS WRITTEN CONSENT OF SAMTEC, INC.

DO NOT SCALE DRAWING

SHEET SCALE: 5:1



520 PARK EAST BLVD, NEW ALBANY, IN 47150
PHONE: 812-944-6733 FAX: 812-948-5047
e-Mail: info@SAMTEC.com code: 55322

DESCRIPTION:
1mm x 1mm DOUBLE VERTICAL SMT TERMINAL STRIP

DWG. NO.
FTMH-1XX-XX-XX-DV-XX-X-XX

BY: PURVIS 04/22/96 SHEET 2 OF 6

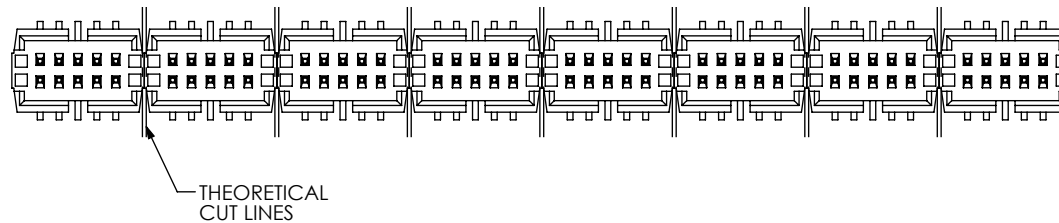

FTMH-105-XX-XX-DV-ES SHOWN (BEFORE CUT)

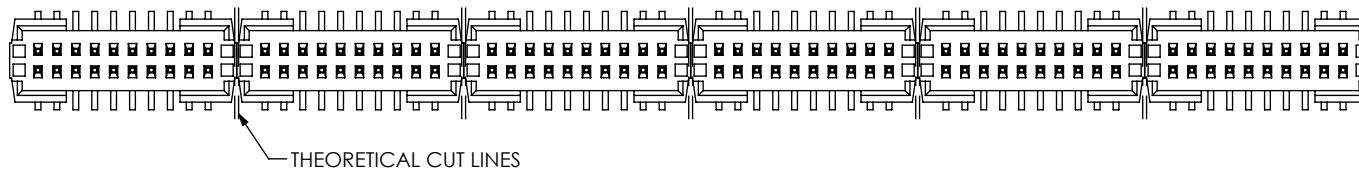

FTMH-110-XX-XX-DV-ES SHOWN (BEFORE CUT)

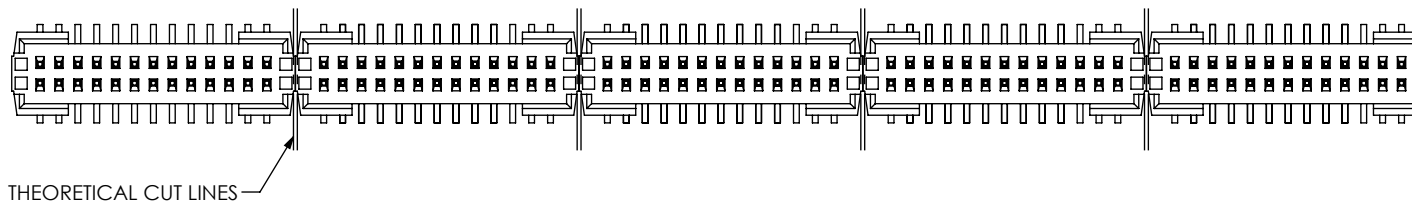

FTMH-113-XX-XX-DV-ES SHOWN (BEFORE CUT)

PROPRIETARY NOTE
 * THIS DOCUMENT CONTAINS CONFIDENTIAL AND PROPRIETARY INFORMATION AND ALL DESIGN, MANUFACTURING, REPRODUCTION, USE, PATENT RIGHTS AND SALES RIGHTS ARE EXPRESSLY RESERVED BY SAMTEC, INC. THIS DOCUMENT SHALL NOT BE DISCLOSED, IN WHOLE OR PART, TO ANY UNAUTHORIZED PERSON OR ENTITY NOR REPRODUCED, TRANSFERRED OR INCORPORATED IN ANY OTHER PROJECT IN ANY MANNER WITHOUT THE EXPRESS WRITTEN CONSENT OF SAMTEC, INC. *

DO NOT SCALE DRAWING

SHEET SCALE: 5:1



520 PARK EAST BLVD, NEW ALBANY, IN 47150
 PHONE: 812-944-6733 FAX: 812-948-5047
 e-Mail: info@SAMTEC.com code: 55322

DESCRIPTION:
1mm x 1mm DOUBLE VERTICAL SMT TERMINAL STRIP

DWG. NO.
FTMH-1XX-XX-XX-DV-XX-X-XX

BY: PURVIS 04/22/96 SHEET 3 OF 6

REVISION BQ

NOTE
 "M" = USED MEASURED DIMENSION (REF)
 "P" = $(("M" - .200[5.08]) / 2) \pm .020[.51]$

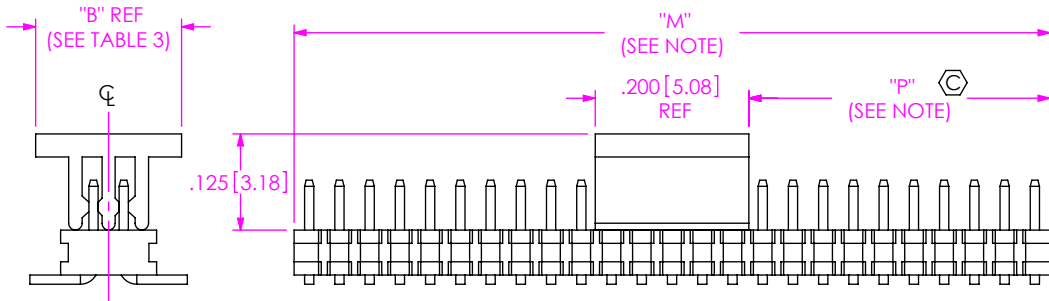

FIG 3
 -P: PICK & PLACE PAD
 FTMH-125-03-X-DV-P SHOWN
 (DIFFERENT AS SHOWN, OTHERWISE SAME AS FIG 1)

TABLE 3	
PAD	"B"
PPP-30	.125[3.18]
PPP-30-NT	.190[4.83]

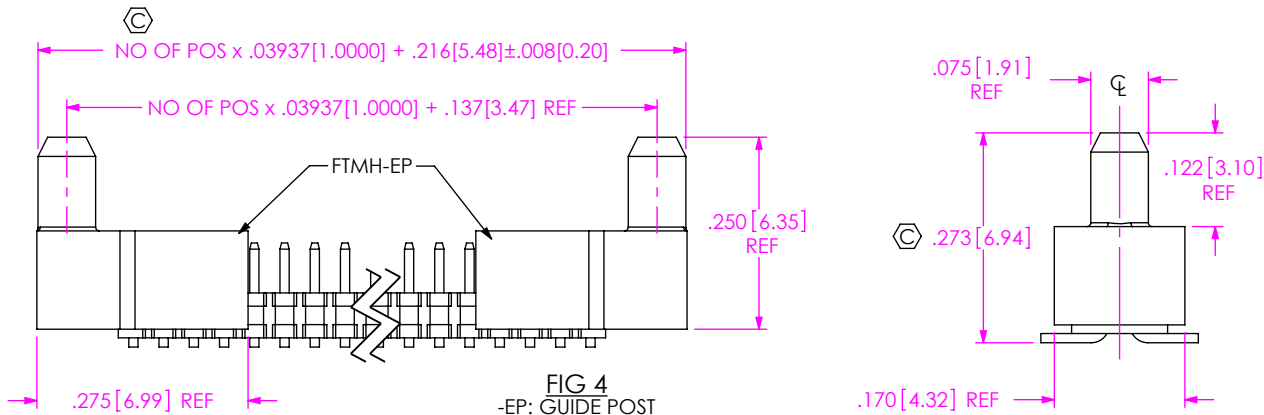

FIG 4
 -EP: GUIDE POST
 FTMH-125-03-X-DV-EP SHOWN
 (DIFFERENT AS SHOWN, OTHERWISE SAME AS FIG 1)

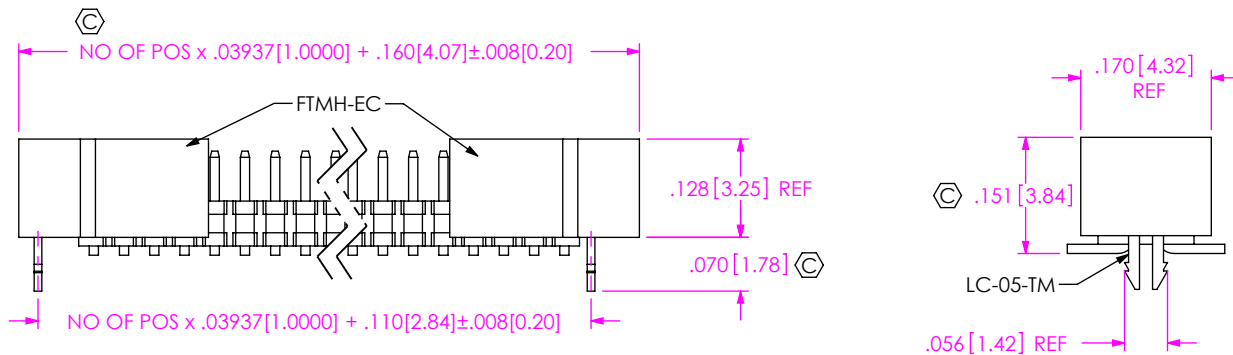

FIG 5
 -EC: LOCKING CLIP
 FTMH-125-03-X-DV-EC SHOWN
 (DIFFERENT AS SHOWN, OTHERWISE SAME AS FIG 1)

PROPRIETARY NOTE
 THIS DOCUMENT CONTAINS CONFIDENTIAL AND PROPRIETARY INFORMATION AND ALL DESIGN, MANUFACTURING, REPRODUCTION, USE, PATENT RIGHTS AND SALES RIGHTS ARE EXPRESSLY RESERVED BY SAMTEC, INC. THIS DOCUMENT SHALL NOT BE DISCLOSED, IN WHOLE OR PART, TO ANY UNAUTHORIZED PERSON OR ENTITY NOR REPRODUCED, TRANSFERRED OR INCORPORATED IN ANY OTHER PROJECT IN ANY MANNER WITHOUT THE EXPRESS WRITTEN CONSENT OF SAMTEC, INC.

DO NOT SCALE DRAWING

SHEET SCALE: 5:1



520 PARK EAST BLVD, NEW ALBANY, IN 47150
 PHONE: 812-944-6733 FAX: 812-948-5047
 e-Mail: info@SAMTEC.com code: 55322

DESCRIPTION:
 1mm x 1mm DOUBLE VERTICAL SMT TERMINAL STRIP

DWG. NO.
FTMH-1XX-XX-XX-DV-XX-X-XX

BY: PURVIS 04/22/96 SHEET 4 OF 6

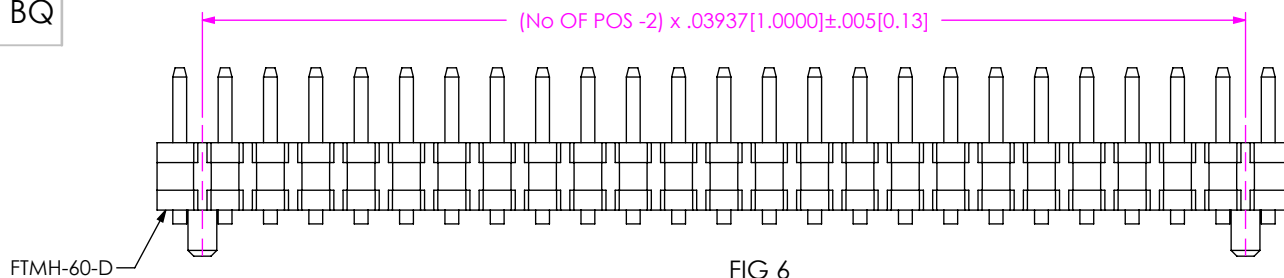

FIG 6
 -A: ALIGNMENT PIN (STAKED)
 (MIN 7 POSITIONS)
 FTMH-125-03-X-DV-A SHOWN
 (DIFFERENT AS SHOWN, OTHERWISE SAME AS FIG 1)

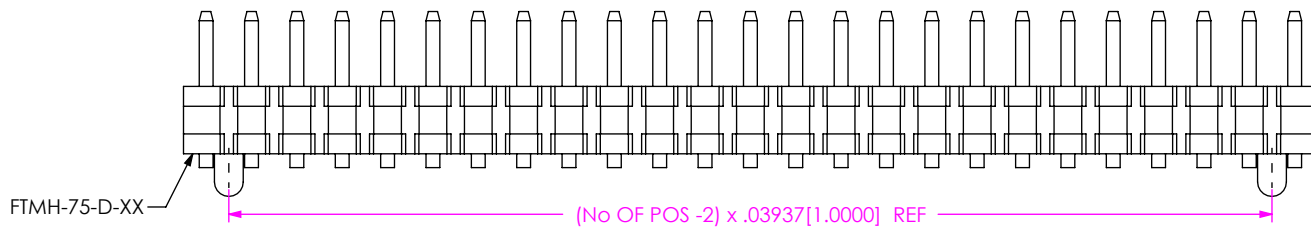
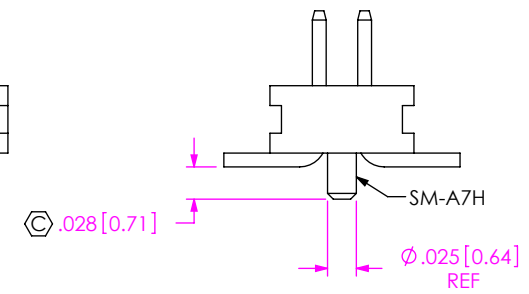
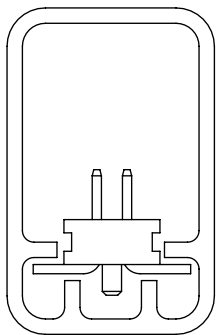
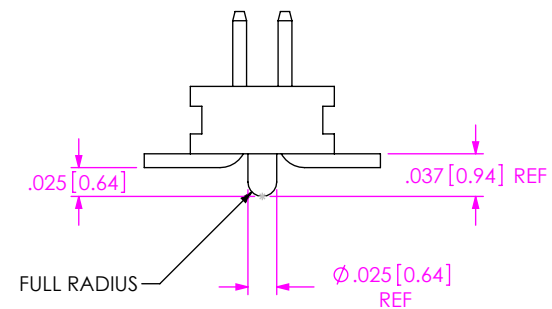
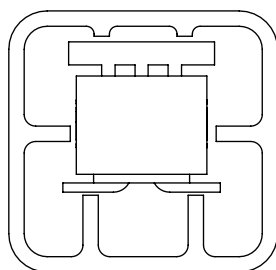

FIG 7
 -A: ALIGNMENT PIN (MOLDED)
 (MIN 3 POSITIONS)
 FTMH-125-03-X-DV-A SHOWN
 (DIFFERENT AS SHOWN, OTHERWISE SAME AS FIG 1)



-A OPTION
 PT-1-24-01-60



-ES-P OPTION
 PT-1-24-01-63

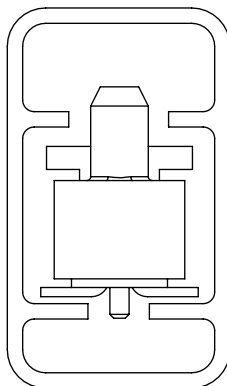

-EP, -EP-A & -EP-A-P OPTION
 PT-1-24-02-15

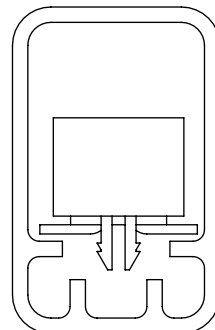

-EC OPTION
 PT-1-24-01-60

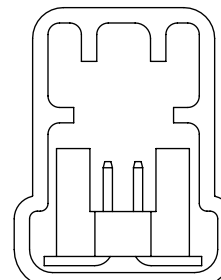

-ES & -ES-A OPTION
 PT-1-24-13-09

F:\DWG\SW\Exisprod\Assembly\1mm\FTMH-1XX-XX-XX-DV-XX-X-XX.SLDDRW

PACKAGING VIEWS

TABLE 2 (SEE NOTE 5 FOR PACKAGING NOTES)			
LEAD STYLE	OPTION (S)	PACKAGING TUBE	TUBE PLUG
-02, -03	-NONE	PT-1-24-01-60	TP-03 (x 2)
-02, -03	-A	PT-1-24-01-60	TP-03 (x 2)
-02, -03	-P, -A-P	PT-1-24-01-60	TP-03 (x 2)
-02, -03	-ES-P	PT-1-24-01-63	TP-24 (x 2)
-02, -03	-EC, -EC-P, -EC-A	PT-1-24-01-60	TP-03 (x 2)
-02, -03	EP, -EP-A, -EP-A-P	PT-1-24-02-15	TP-03 (x 2)
-02, -03	-ES, -ES-A	PT-1-24-13-09	TP-24 (x 2)

PROPRIETARY NOTE
 THIS DOCUMENT CONTAINS CONFIDENTIAL AND PROPRIETARY INFORMATION AND ALL DESIGN, MANUFACTURING, REPRODUCTION, USE, PATENT RIGHTS AND SALES RIGHTS ARE EXPRESSLY RESERVED BY SAMTEC, INC. THIS DOCUMENT SHALL NOT BE DISCLOSED, IN WHOLE OR PART, TO ANY UNAUTHORIZED PERSON OR ENTITY NOR REPRODUCED, TRANSFERRED OR INCORPORATED IN ANY OTHER PROJECT IN ANY MANNER WITHOUT THE EXPRESS WRITTEN CONSENT OF SAMTEC, INC.
 DO NOT SCALE DRAWING
 SHEET SCALE: 5:1

520 PARK EAST BLVD, NEW ALBANY, IN 47150
 PHONE: 812-944-6733 FAX: 812-948-5047
 e-Mail: info@SAMTEC.com code: 55322

DESCRIPTION:
 1mm x 1mm DOUBLE VERTICAL SMT TERMINAL STRIP
 DWG. NO.
FTMH-1XX-XX-XX-DV-XX-X-XX
 BY: PURVIS 04/22/96 SHEET 5 OF 6

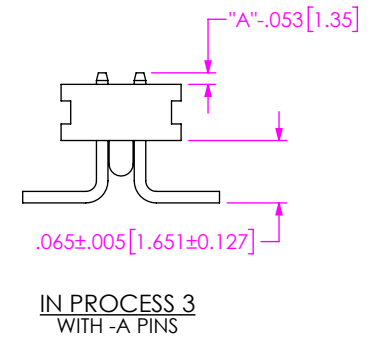
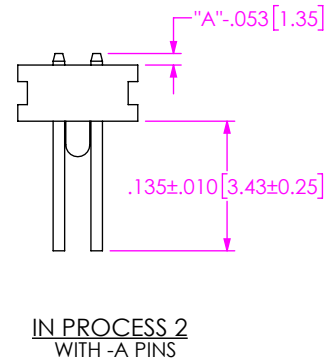
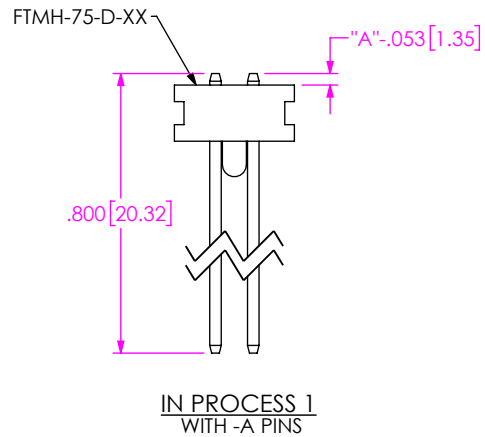
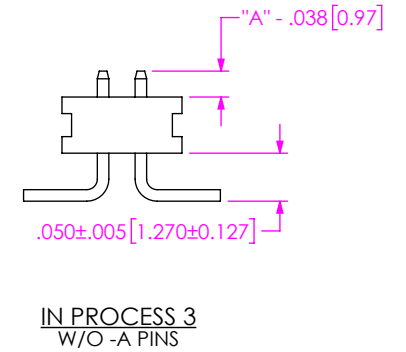
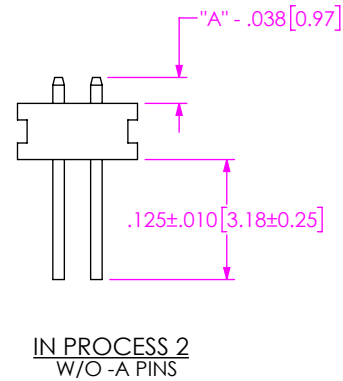
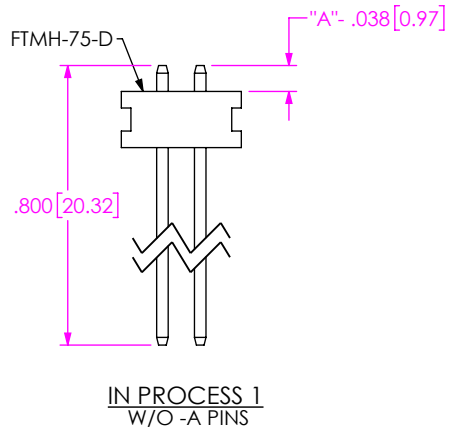

PROPRIETARY NOTE
 THIS DOCUMENT CONTAINS CONFIDENTIAL AND PROPRIETARY INFORMATION AND ALL DESIGN, MANUFACTURING, REPRODUCTION, USE, PATENT RIGHTS AND SALES RIGHTS ARE EXPRESSLY RESERVED BY SAMTEC, INC. THIS DOCUMENT SHALL NOT BE DISCLOSED, IN WHOLE OR PART, TO ANY UNAUTHORIZED PERSON OR ENTITY NOR REPRODUCED, TRANSFERRED OR INCORPORATED IN ANY OTHER PROJECT IN ANY MANNER WITHOUT THE EXPRESS WRITTEN CONSENT OF SAMTEC, INC.

samtec
 520 PARK EAST BLVD, NEW ALBANY, IN 47150
 PHONE: 812-944-6733 FAX: 812-948-5047
 e-Mail: info@SAMTEC.com code: 55322

DO NOT SCALE DRAWING

SHEET SCALE: 5:1

DESCRIPTION:
 1mm x 1mm DOUBLE VERTICAL SMT TERMINAL STRIP

DWG. NO.
FTMH-1XX-XX-XX-DV-XX-X-XX

BY: PURVIS 04/22/96 SHEET 6 OF 6