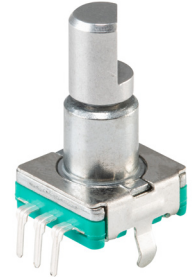

SERIES: RIC11 | **DESCRIPTION:** MECHANICAL INCREMENTAL ENCODER

FEATURES

- multiple shaft options
- different mounting options
- different resolution and detent options

ELECTRICAL

parameter	conditions/description	min	typ	max	units
power supply			5		V
current consumption	each lead	0.5		10	mA
	common lead	0.5	1	10	mA
output	2-bit quadrature, channel A leads channel B by 90° with counter-clockwise rotation				
output phase difference	$\Delta T \geq 6$ ms @ 60 rpm (see output waveform)				
output resolution	15, 20 PPR				
detent step angle	20 detent models	16	18	20	°
	30 detent models	10	12	14	°
insulation resistance	at 250 Vdc, for 1 minute between terminals and bushing	100			M Ω
dielectric strength	for 1 minute between terminals and bushing	300			Vac

Notes: 1. All specifications measured at 15-35°C, humidity at 25-85%, under 86-106 kPa pressure, unless otherwise noted.

PUSH SWITCH SPECIFICATIONS

parameter	conditions/description	min	typ	max	units	
rating	5 Vdc, 10 mA (1 mA min)					
contact resistance	voltage step-down test at 5 Vdc, 1 mA				100	m Ω
insulation resistance	at 250 Vdc, for 1 minute between terminals and bushing	100			M Ω	
dielectric strength	between terminals and bushing				Vac	
	for 1 minute (leakage current 1 mA) for 2 seconds (leakage current 1 mA)	250 300			Vac	
operating push force		3	5	7	N	
travel		0.3	0.5	0.7	mm	
bounce	shaft rotated at 1 cycles/s (OFF-ON-OFF)				10	ms
push switch life	at 1800~2000 cycles/hour without electrical load	20,000			cycles	

MECHANICAL

parameter	conditions/description	min	typ	max	units
shaft load	pull static load for 20 seconds		100		N
	push static load for 10 seconds		100		N
rotational torque		10	15	20	mN·m
terminal strength	a static load of 3 N applied to tip of terminals for 10 s				
rotational angle	continuous		360		°
side thrust strength of shaft	a load of 80 N applied at the point 5 mm from the tip of the shaft perpendicular to the shaft axis for 10 s				
shaft play in rotational wobble	testing by angle board			2	°
shaft play in axial direction	pull/push load of 0.5 N applied on the shaft			0.2	mm
rotational life	at 600~800 cycles/hour without electrical load		100,000		cycles

ENVIRONMENTAL

parameter	conditions/description	min	typ	max	units
operating temperature		-40		85	°C
storage temperature		-40		85	°C
RoHS	yes				

SOLDERABILITY

parameter	conditions/description	min	typ	max	units
hand soldering	for maximum 3 seconds			350	°C
reflow soldering	only suitable for surface mount models		260		°C

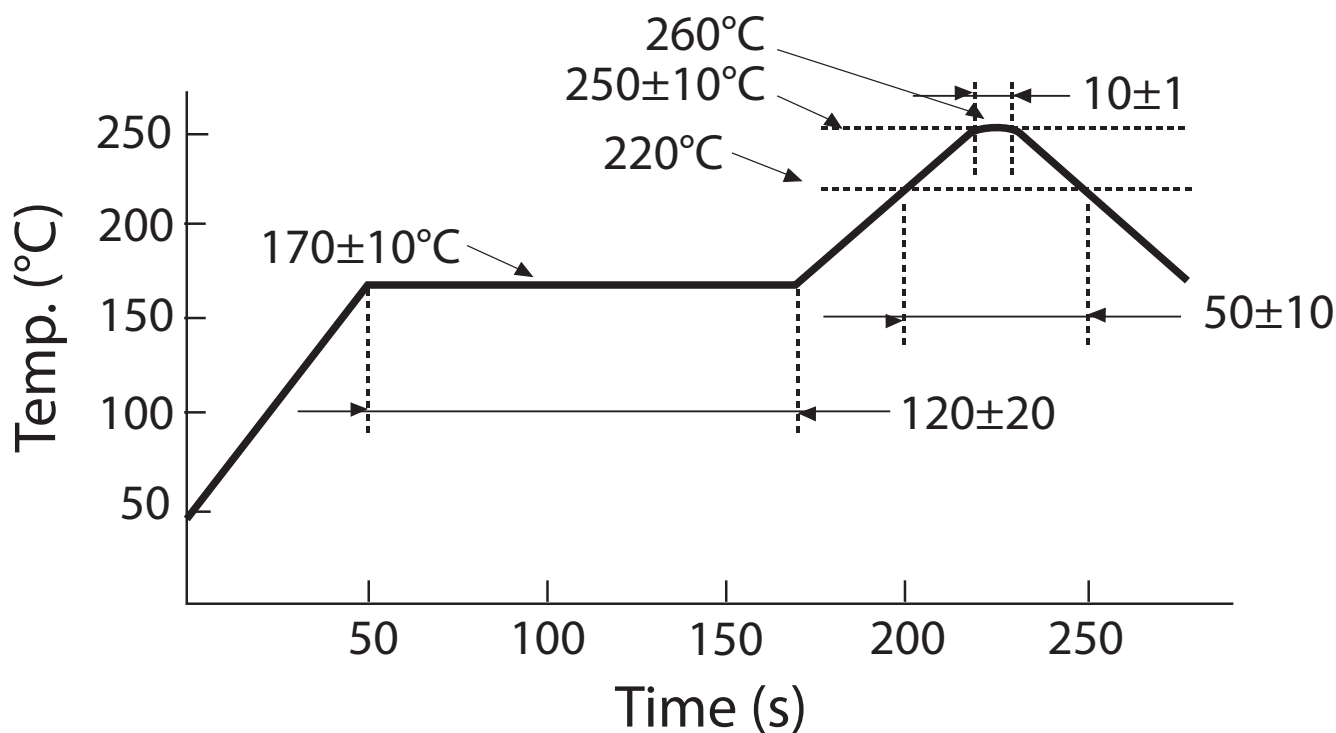

PART NUMBER KEY

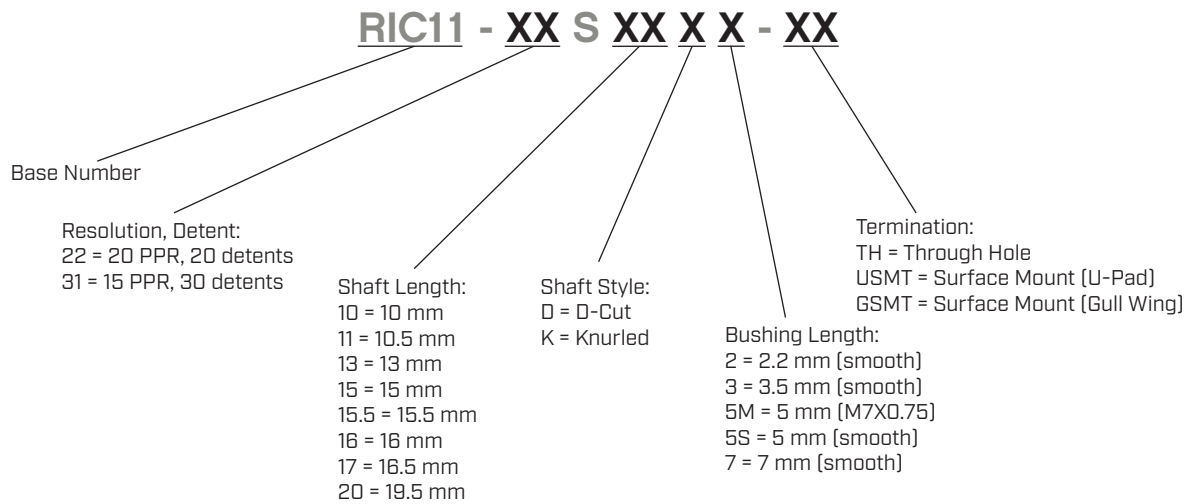

Note: 2. See Shaft Types and Mechanical Drawings for available configurations.

OUTPUT WAVEFORM

20 PPR, 20 Detent Models

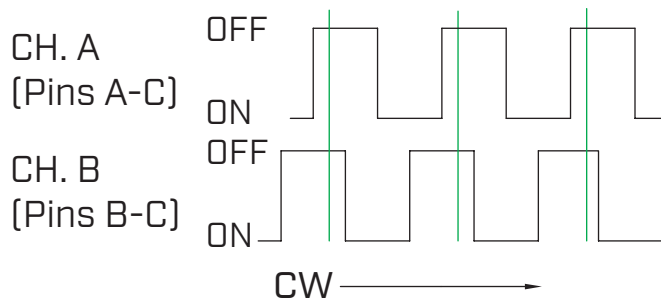

15 PPR, 30 Detent Models

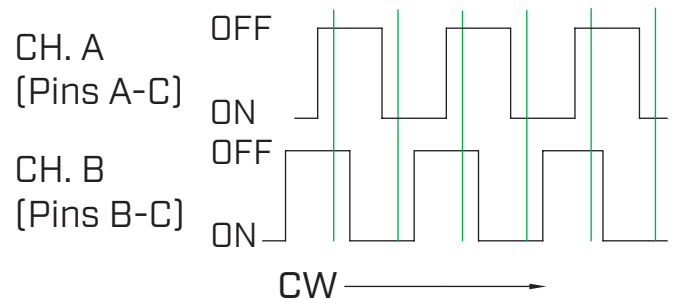

SWITCHING CHARACTERISTICS

parameter	conditions/description	value
chattering	signal's passage of time from 1.5 V to 3.5 V of each switching position (OFF to ON or ON to OFF)	$t_1, t_3 \leq 3 \text{ ms}$
sliding noise (bounce)	time of voltage change exceeds 1.5 V in code ON area. When the bounce has code ON time less than 1 ms between chattering [t_1 or t_3], the voltage change shall be regarded as a part of chattering. When the code ON time between 2 bounces is less than 1 ms, they are regarded as 1 linked bounce.	$t_2 \leq 2 \text{ ms}$
sliding noise	voltage change in code OFF area	3.5 V min

Notes: 3. Testing at 60 RPM.
 4. Code OFF: The area which the voltage is 3.5 V or more. Code ON: The area which the voltage is 1.5 V or less.

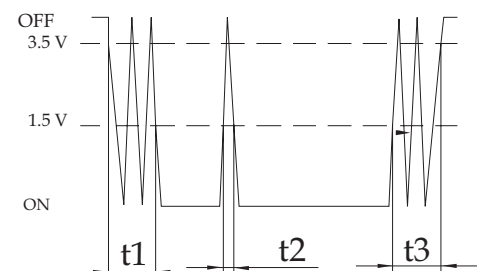
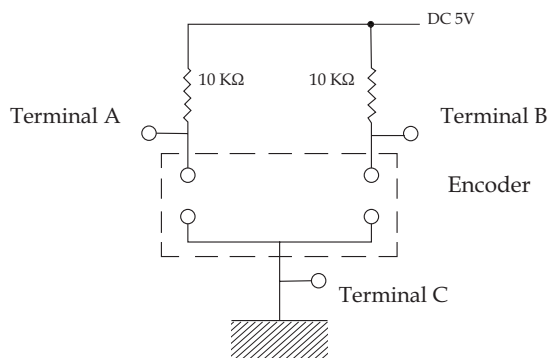

PHASE DIFFERENCE

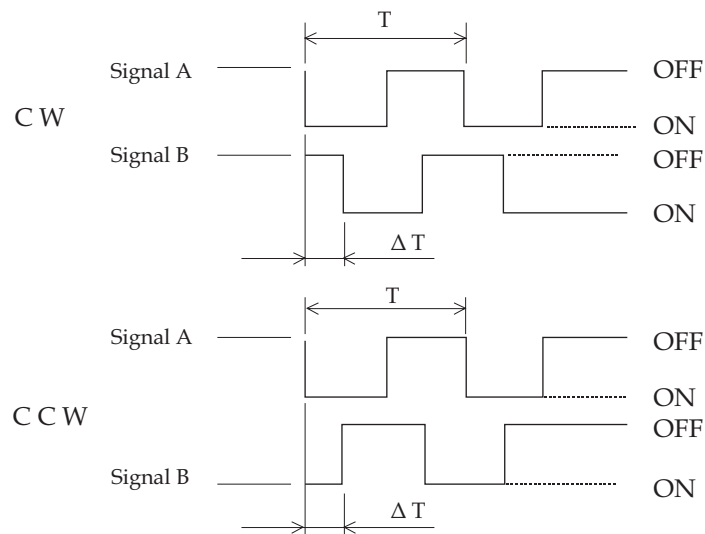

At 60 RPM constant speed: $\Delta T \geq 6$ ms

SHAFT TYPES

units: mm
 tolerance:
 $X \leq 10.00$: ± 0.30 mm
 $10.00 < X \leq 100.00$: ± 0.50 mm
 unless otherwise noted

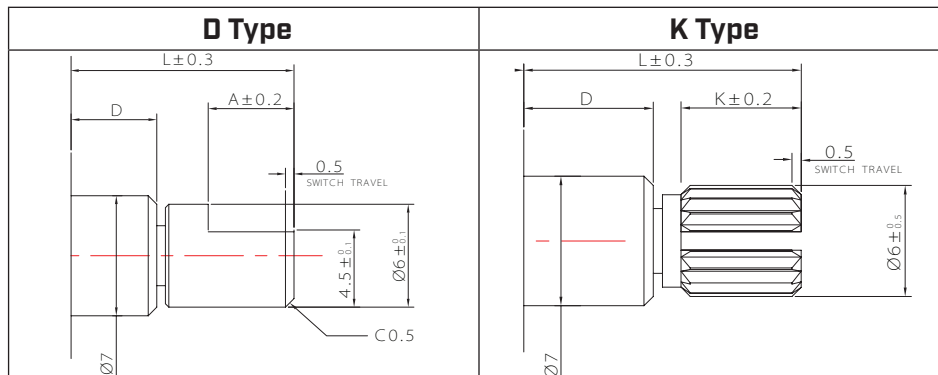

D=5				
	10D	13D	16D	20D
L	10	13	16	19.5
A	4	5	10	11

	10K	10K	11K	15K
D	2.2	3.5	5	7
L	10	10	10.5	15
K	5	5	3.5	6.5

D=7				
	15D	15.5D	17D	20D
L	15	15.5	16.5	19.5
A	7	6	8	11

MECHANICAL DRAWING (RIC11-31S10K2-GSMT)

units: mm
 tolerance:
 $X \leq 10.00$: ± 0.30 mm
 $10.00 < X \leq 100.00$: ± 0.50 mm
 unless otherwise noted

DESCRIPTION	MATERIAL	PLATING/COLOR
housing	LCP	
bracket	SPCC	
bushing	zinc alloy	
shaft	aluminum	
terminals	phosphor copper	

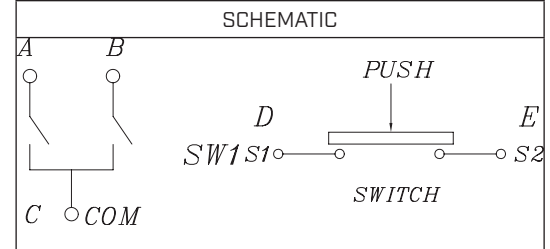
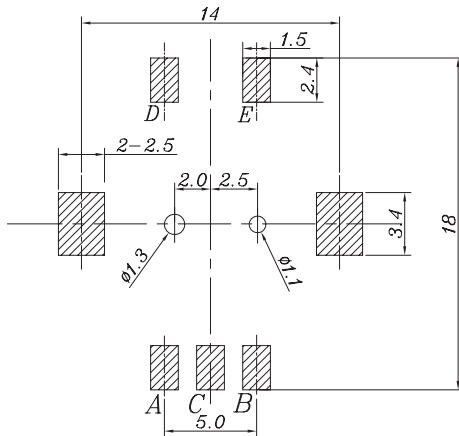
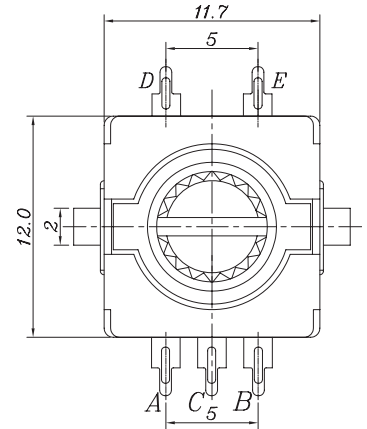
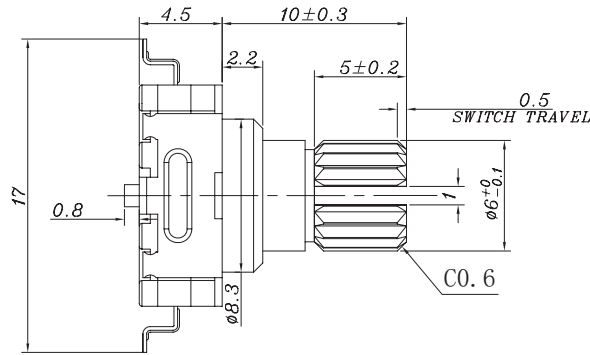
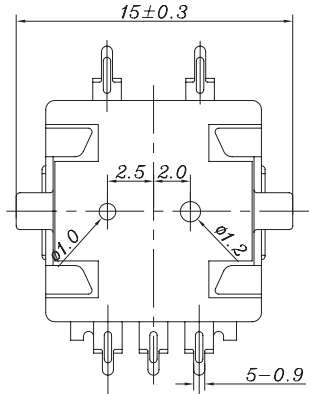

Recommended PCB Layout
 Top View

MECHANICAL DRAWING (THROUGH HOLE MODELS)

units: mm
 tolerance:
 $X \leq 10.00$: ± 0.30 mm
 $10.00 < X \leq 100.00$: ± 0.50 mm
 unless otherwise noted

DESCRIPTION	MATERIAL	PLATING/COLOR
housing	PBT	
bracket	SPCC	
bushing	zinc alloy	
shaft	aluminum/zinc alloy	
terminals	phosphor copper	

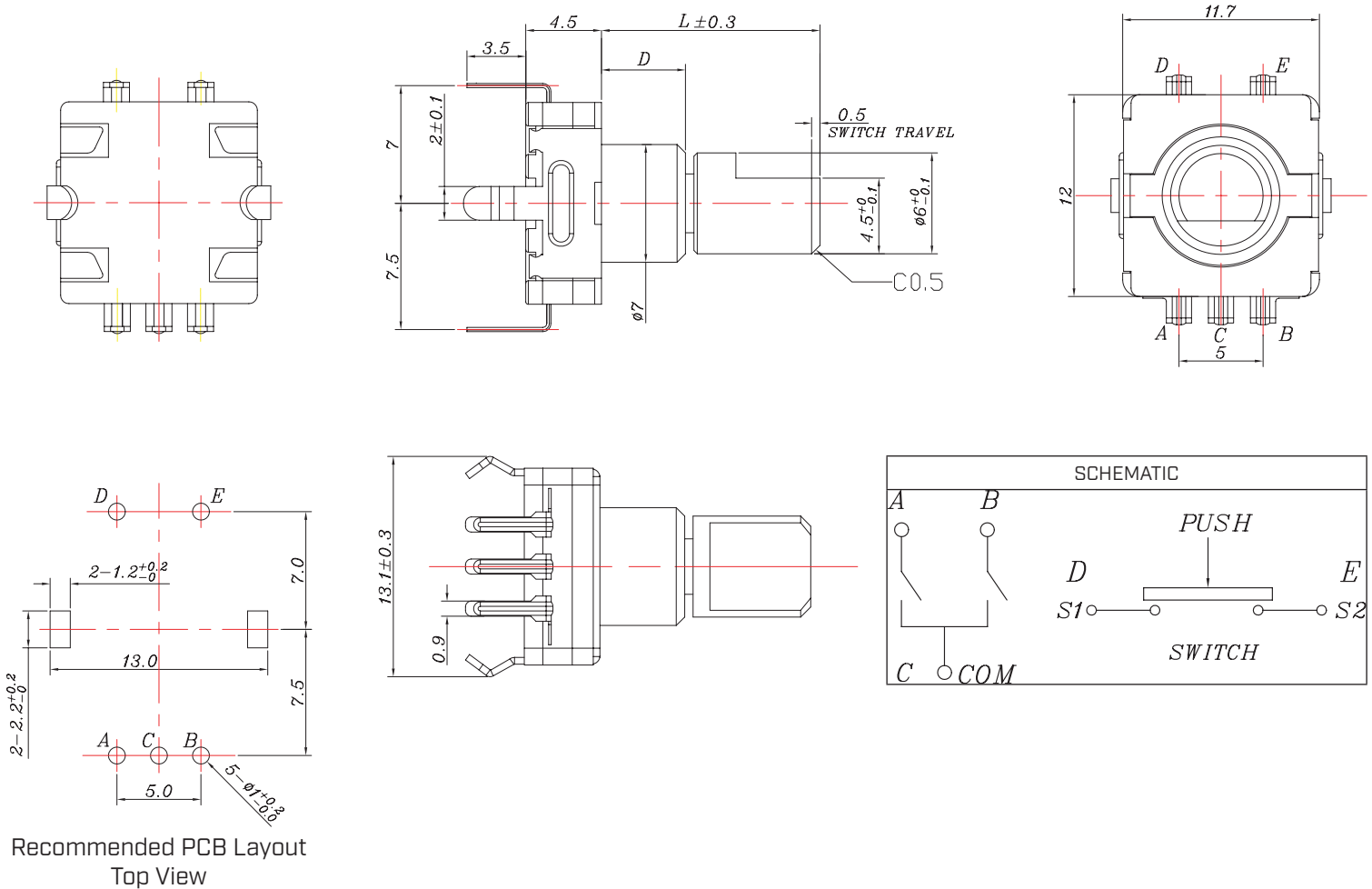

MECHANICAL DRAWING (GULL WING SMT MODELS)

units: mm
 tolerance:
 $X \leq 10.00$: ± 0.30 mm
 $10.00 < X \leq 100.00$: ± 0.50 mm
 unless otherwise noted

DESCRIPTION	MATERIAL	PLATING/COLOR
housing	LCP	
bracket	SPCC	
bushing	zinc alloy	
shaft	aluminum/zinc alloy	
terminals	phosphor copper	

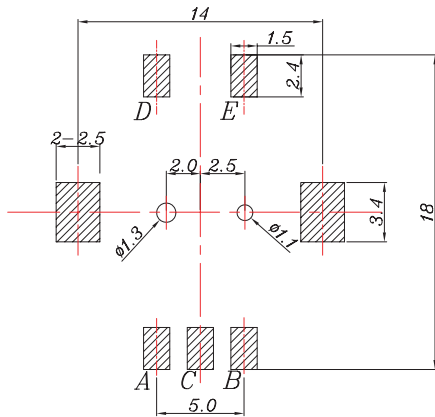
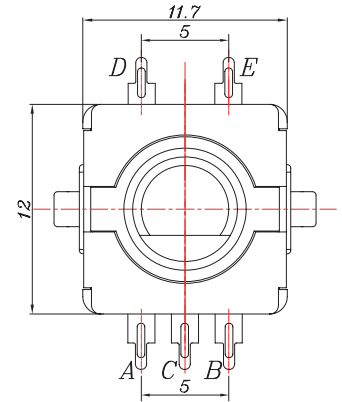
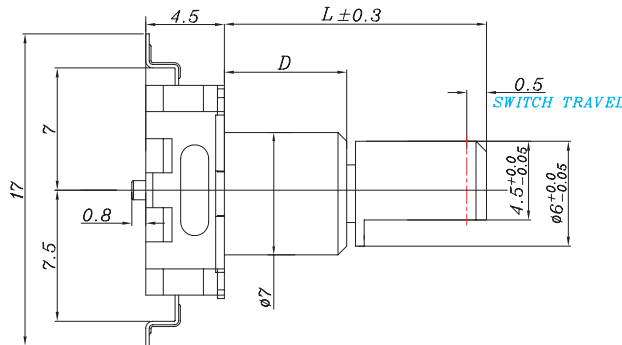
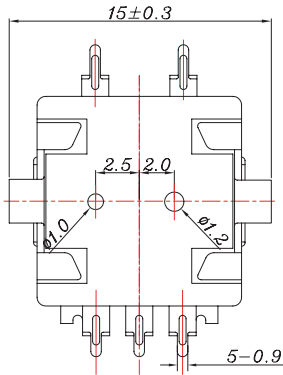

Recommended PCB Layout
Top View

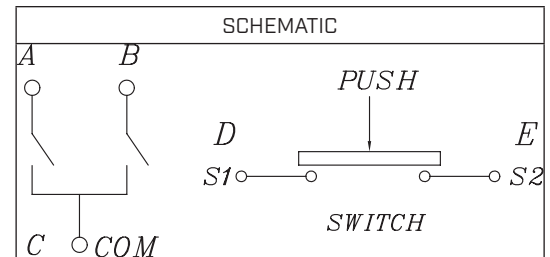

MOUNTING HARDWARE

units: mm

Nut

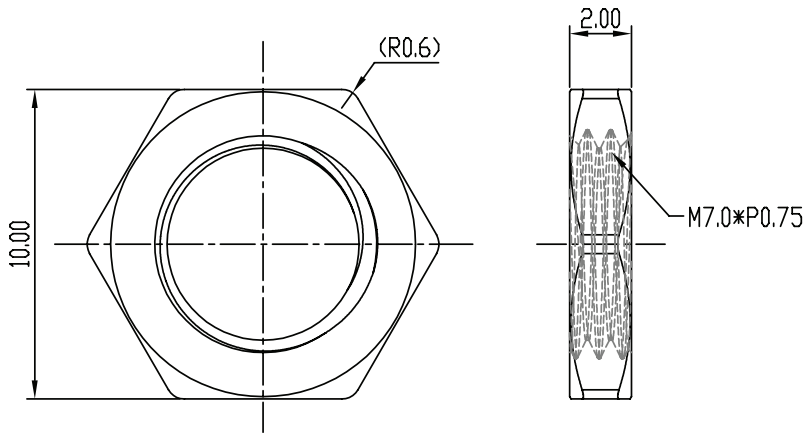

Washer

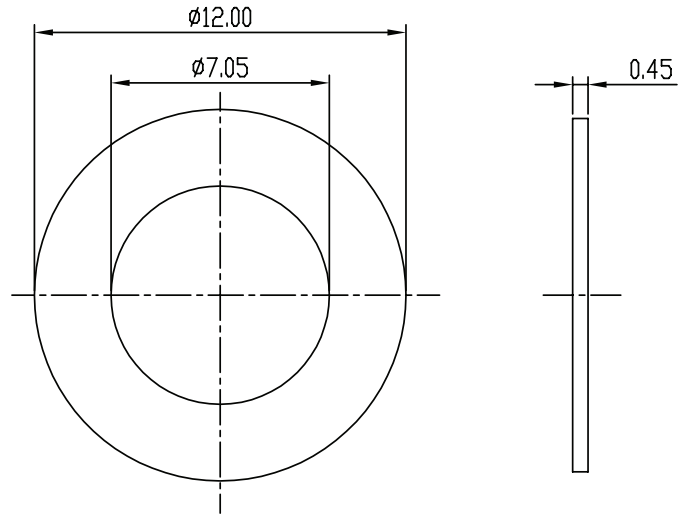

REVISION HISTORY

rev.	description	date
1.0	initial release	09/20/2023
1.01	CUI Devices rebranded to Same Sky	09/12/2024
1.02	updated datasheet	04/21/2025
1.03	updated datasheet	04/29/2025
1.04	updated nut and washer drawings	07/01/2025

The revision history provided is for informational purposes only and is believed to be accurate.



Same Sky offers a one (1) year limited warranty. Complete warranty information is listed on our website.

Same Sky reserves the right to make changes to the product at any time without notice. Information provided by Same Sky is believed to be accurate and reliable. However, no responsibility is assumed by Same Sky for its use, nor for any infringements of patents or other rights of third parties which may result from its use.

Same Sky products are not authorized or warranted for use as critical components in equipment that requires an extremely high level of reliability. A critical component is any component of a life support device or system whose failure to perform can be reasonably expected to cause the failure of the life support device or system, or to affect its safety or effectiveness.

[sameskydevices.com](https://www.sameskydevices.com)