

52957 ✓ ACTIVE

PLASTI-GRIP

TE Internal #: 52957

Spring Spade Terminal, 16 – 14 AWG, #10 Stud, 4.82 mm [.19 in] Stud Diameter, Closed Barrel, Straight, Tin Plating, Partially Insulated, PLASTI-GRIP

[View on TE.com >](#)



Terminals & Splices > Spade Terminals

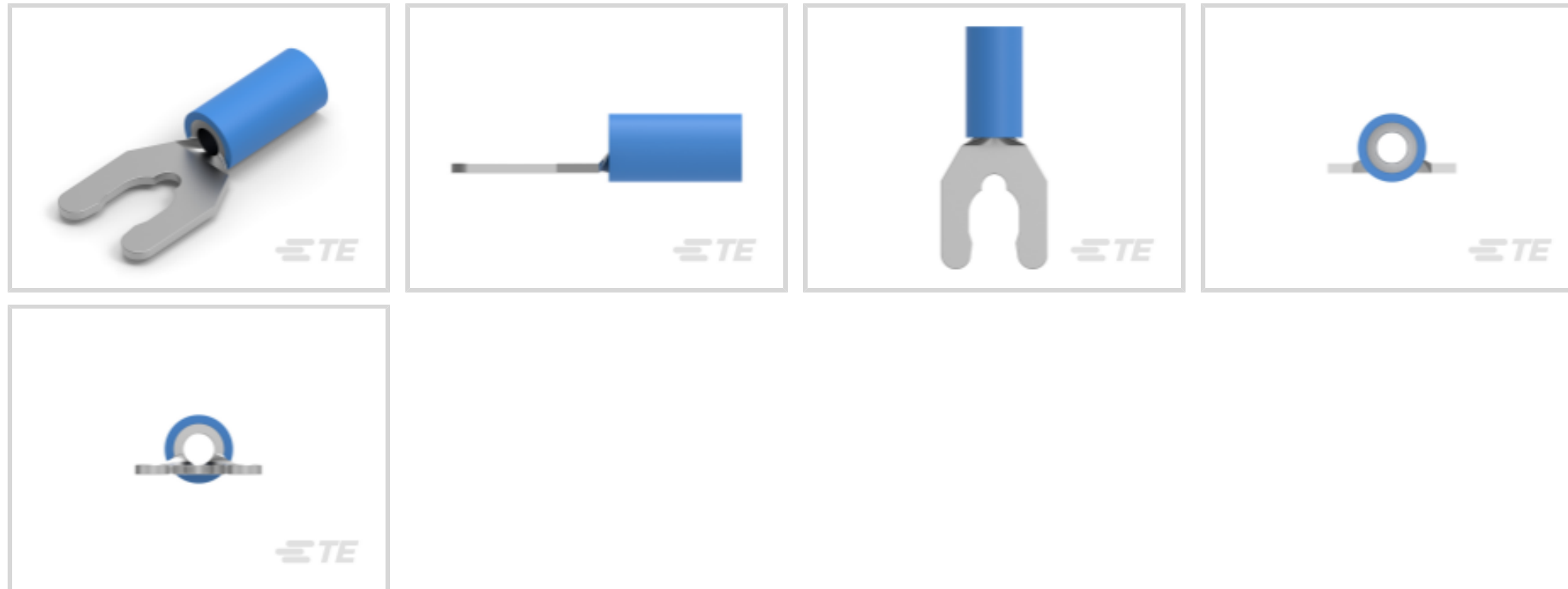

Spade Terminal Type: **Spring Spade Terminal**

Wire Size: **2050 – 5180 CMA**

Stud Size: **#10**

### Features

#### Mechanical Attachment

Wire Insulation Support	With
-------------------------	------

#### Electrical Characteristics

Voltage Rating	600 V
----------------	-------

#### Industry Standards

Government Qualified Terminal	No
-------------------------------	----

#### Body Features

Insulation Sleeve Color	Blue
-------------------------	------

Stripe Color	Blue
--------------	------

#### Packaging Features

Packaging Quantity	1000
--------------------	------

Packaging Method	Loose Piece
------------------	-------------

#### Product Type Features

Terminal Features	Inspection Slot
-------------------	-----------------

Stud Size	#10
-----------	-----

Sealable	No
----------	----



Wire Insulation Support Retention Type	Insulation Support
--	--------------------

### Contact Features

Spade Terminal Type	Spring Spade Terminal
Barrel Type	Closed
Terminal Orientation	Straight
Terminal Plating Material	Tin

### Dimensions

Wire Size	2050 – 5180 CMA
Stud Diameter	4.82 mm [.19 in]
Tongue Thickness	.79 mm [.031 in]
Product Length	23.37 mm [.92 in]
Compatible Insulation Diameter (Max)	4.9 mm [.193 in]
Compatible Insulation Diameter Range	3 – 4.9 mm [.118 – .193 in]

### Usage Conditions

Insulation Option	Partially Insulated
-------------------	---------------------

### Operation/Application

Compatible With Wire Base Material	Copper
Compatible With Wire Plating Material	Tin

### Other

EU RoHS Compliance	Compliant
EU ELV Compliance	Compliant

### Product Compliance

[For compliance documentation, visit the product page on TE.com>](#)

EU RoHS Directive 2011/65/EU	Compliant
EU ELV Directive 2000/53/EC	Compliant
China RoHS 2 Directive MIIT Order No 32, 2016	No Restricted Materials Above Threshold
EU REACH Regulation (EC) No. 1907/2006	Current ECHA Candidate List: JUNE 2024 (241) Candidate List Declared Against: JUNE 2024 (241) Does not contain REACH SVHC
Halogen Content	Not Low Halogen - contains Br or Cl > 900 ppm.

Solder Process Capability

Not applicable for solder process capability

Product Compliance Disclaimer

This information is provided based on reasonable inquiry of our suppliers and represents our current actual knowledge based on the information they provided. This information is subject to change. The part numbers that TE has identified as EU RoHS compliant have a maximum concentration of 0.1% by weight in homogenous materials for lead, hexavalent chromium, mercury, PBB, PBDE, DBP, BBP, DEHP, DIBP, and 0.01% for cadmium, or qualify for an exemption to these limits as defined in the Annexes of Directive 2011/65/EU (RoHS2). Finished electrical and electronic equipment products will be CE marked as required by Directive 2011/65/EU. Components may not be CE marked. Additionally, the part numbers that TE has identified as EU ELV compliant have a maximum concentration of 0.1% by weight in homogenous materials for lead, hexavalent chromium, and mercury, and 0.01% for cadmium, or qualify for an exemption to these limits as defined in the Annexes of Directive 2000/53/EC (ELV). Regarding the REACH Regulation, the information TE provides on SVHC in articles for this part number is based on the latest European Chemicals Agency (ECHA) 'Guidance on requirements for substances in articles' posted at this URL: <https://echa.europa.eu/guidance-documents/guidance-on-reach>

### Compatible Parts



REPRESENTATION ONLY

TE Part # 525691  
DAHT PG PIDG 16-14 ASSY



TE Part # 52957-1  
TERMINAL,PG SPR SPD 16-14 10



TE Part # 52957-3  
TERMINAL,PG SPR SPD 16-14 10



TE Part # 59824-1  
TETRA-CRIMP PIDG PG FASTON 22-10 ASSY



TE Part # 47807-1  
DIES PIDG 16-14 DIE SET



TE Part # 58423-1  
DIE, RBY IS9252



TE Part # 58433-3  
PRO CR ASSY, RBY IS9252

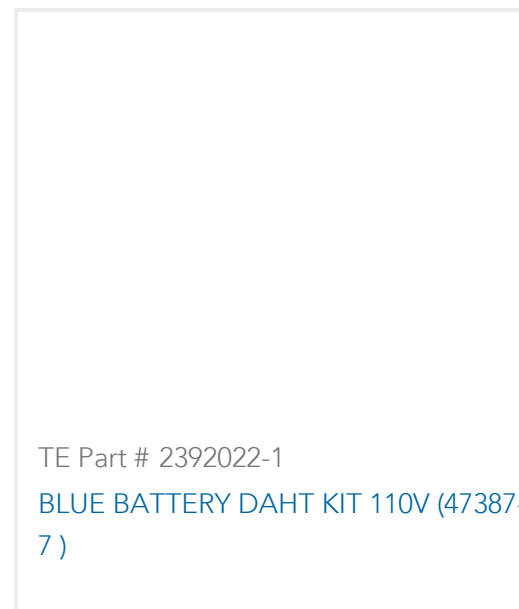

TE Part # 2392022-1  
BLUE BATTERY DAHT KIT 110V (47387-7)



TE Part # 169404  
CERTI-LOK DIE



TE Part # 539691-2  
ERGO DIE R.B.Y



TE Part # 2063030-1  
SDE DIESET, RBY, UL



REPRESENTATION ONLY

TE Part # 47387-7  
DAHT PG PIDG 16-12 ASSY

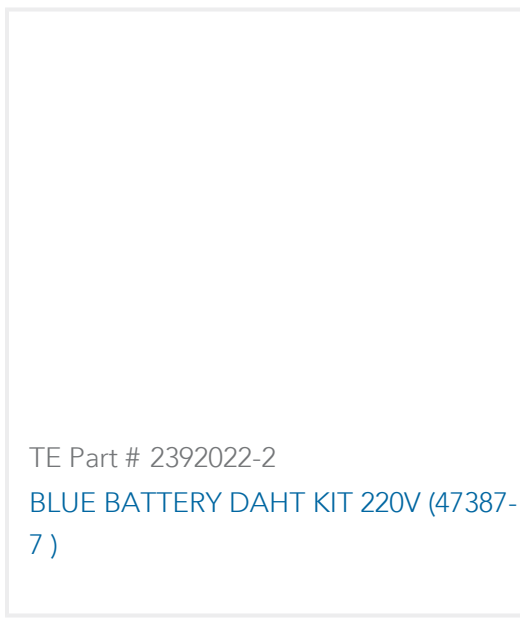

Also in the Series | **PLASTI-GRIP**

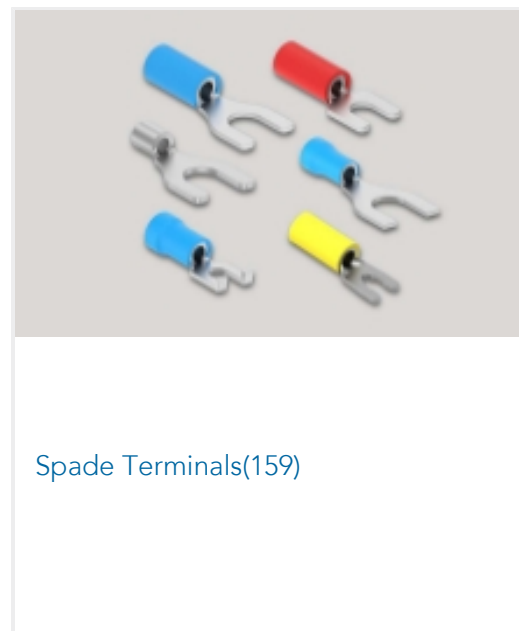
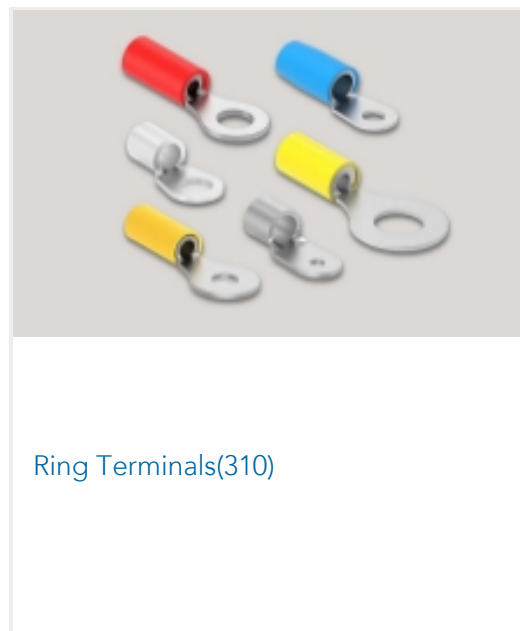
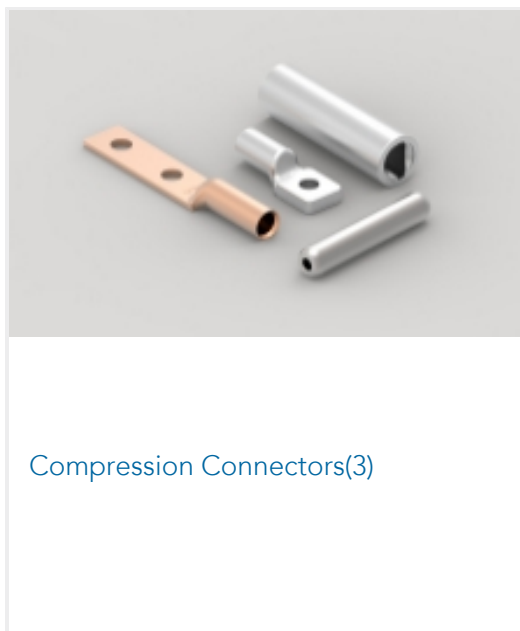

Customers Also Bought

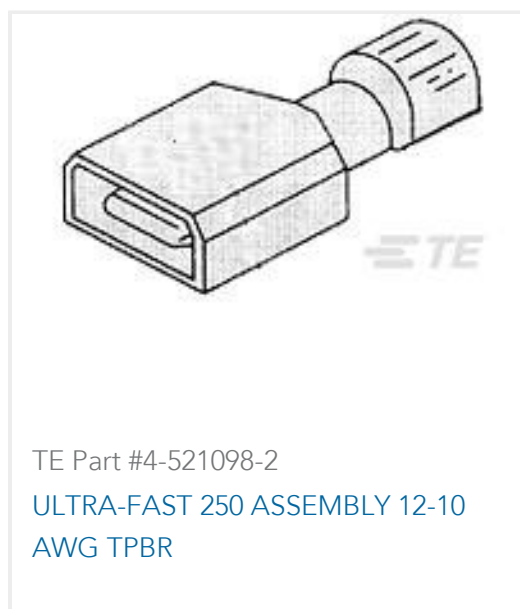

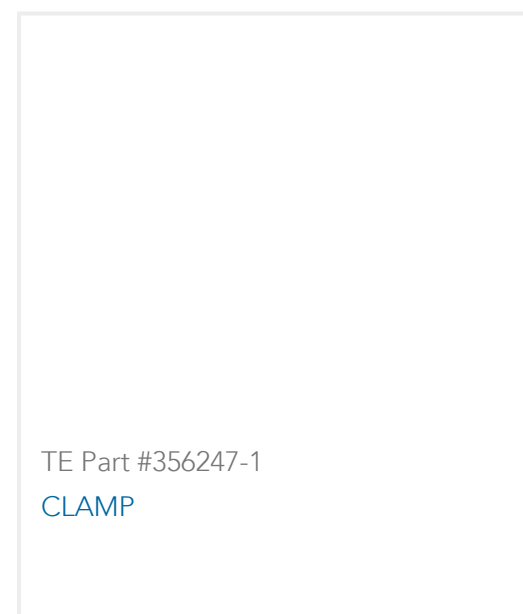
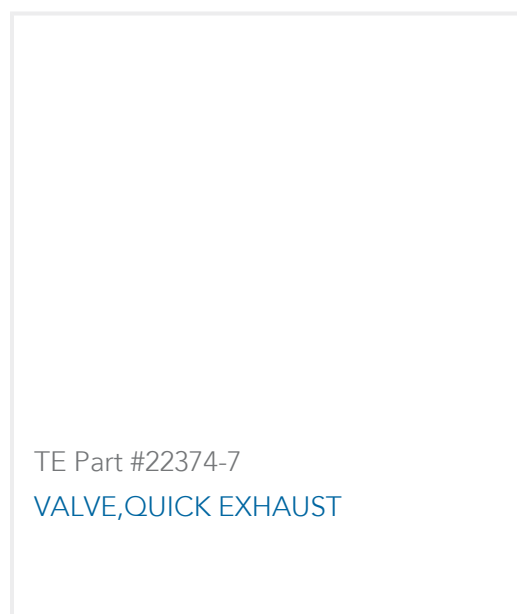

## Documents

### Product Drawings

[TERMINAL, PG SPR SPD 16-14 10](#)

English

### CAD Files

#### 3D PDF

3D

Customer View Model

[ENG\\_CVM\\_CVM\\_52957\\_T.2d\\_dxf.zip](#)

English

Customer View Model

[ENG\\_CVM\\_CVM\\_52957\\_T.3d\\_igs.zip](#)

English

Customer View Model

[ENG\\_CVM\\_CVM\\_52957\\_T.3d\\_stp.zip](#)

English

Customer View Model

[ENG\\_CVM\\_52957\\_N.3d\\_igs.zip](#)

English

Customer View Model

[ENG\\_CVM\\_52957\\_N.3d\\_stp.zip](#)

English

Customer View Model

[ENG\\_CVM\\_52957\\_N.2d\\_dxf.zip](#)

English

#### 3D PDF

English

By downloading the CAD file I accept and agree to the [Terms and Conditions](#) of use.

### Product Specifications

[Application Specification](#)

English

### Instruction Sheets

[AMP\\* PIDG\\* \(VINYL\) & PLASTI-GRIP\\* SHORT SPRING SPADE TERMINALS FOR BAR](#)

English



**Instruction Sheet (U.S.)**

English

---

**Agency Approvals**

**UL Report**

English

**UL Report**

English