

PCB LAYOUT : COMPONENT SIDE
RECOMMENDED PCB THICKNESS : (1.57)

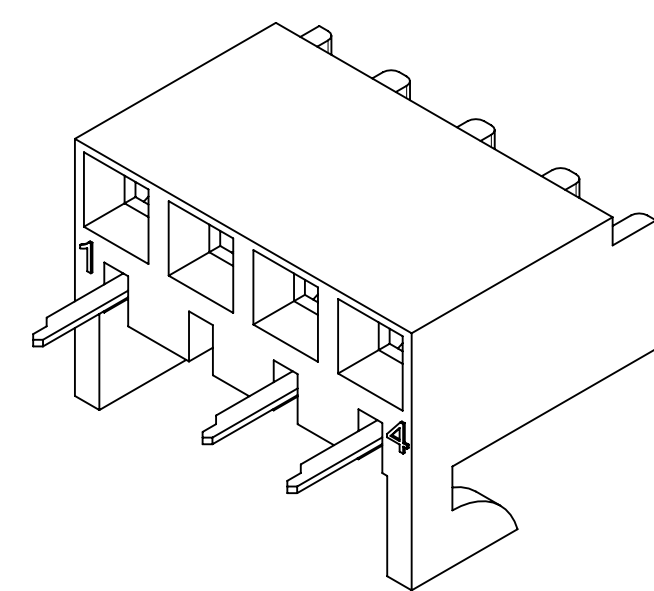

PN : 418150702
4CKT (CKT-2 VOID)

- NOTES:
- MATERIAL: HOUSING: POLYESTER, RATED UL 94V-0, COLOR: NATURAL (WHITE)
 - FINISH:
(197) = OVERALL REFLOWED MATTE TIN: 0.00152/.000060 MIN
OVER 0.00127/.000050 MIN NICKEL.
 - PRODUCT SPECIFICATION: PS-08-50
 - PACKAGING: PK-41815-001 (TRAY)
 - SOLDERABILITY: WHEN PARTS ARE SOLDERED AT A TEMPERATURE OF 230°C (446°F) FOR 5 SECONDS EACH SOLDERED SURFACE SHALL BE A MINIMUM OF 95% COVERED WITH A SMOOTH CONTINUOUS ADHERENT COATING. FOR ADDITIONAL INFORMATION SEE SMES-152.
 - PARTS ARE STACKABLE END TO END ON (3.96) .156 CENTERLINE.
 - THIS PART CONFORMS TO CLASS B REQUIREMENTS OF COSMETIC SPEC PS-45499-002.
 - DIMENSION MEASURED WITH TERMINAL PUSHED IN AGAINST THE STOP.

THIS DRAWING CONTAINS INFORMATION THAT IS PROPRIETARY TO MOLEX ELECTRONIC TECHNOLOGIES, LLC AND SHOULD NOT BE USED WITHOUT WRITTEN PERMISSION									
DIMENSION UNITS		SCALE		CURRENT REV DESC: UPDATED TO W/O RAMP VERSION				molex	
mm		NTS							
GENERAL TOLERANCES (UNLESS SPECIFIED)				EC NO: 642014		DRWN: YVENKATESWAR		2020/07/06	
				CHK'D: YVENKATESWAR		2020/07/22		KK 156 RECEPTACLE ASSEMBLY	
				APPR: ISHWARG		2020/07/22		41815 SERIES	
				INITIAL REVISION:		DRWN: YVENKATESWAR		RESTRICTED PRODUCT CUSTOMER DRAWING	
				APPR: ISHWARG		2020/06/19		DOCUMENT NUMBER	
				ANGULAR TOL ± 0.5°		2020/07/22		418150702-RSD	
DRAFT WHERE APPLICABLE MUST REMAIN WITHIN DIMENSIONS				THIRD ANGLE PROJECTION		DRAWING		SERIES	
				B-SIZE		41815		MATERIAL NUMBER	
						418150702		CUSTOMER	
								SHEET NUMBER	
								1 OF 1	