

Power Resistor for Mounting Onto a Heatsink Thick Film Technology



RoHS
COMPLIANT

FEATURES

- AEC-Q200 qualified
- Compliant with requirement #26 of NF-EN45545-2
- High power 800 W at 85 °C bottom case temperature
- Wide resistance range: 0.3 Ω to 900 kΩ E24 series
- Non inductive
- Easy mounting
- Low thermal radiation of the case
- Material categorization: for definitions of compliance please see www.vishay.com/doc?99912

LINKS TO ADDITIONAL RESOURCES

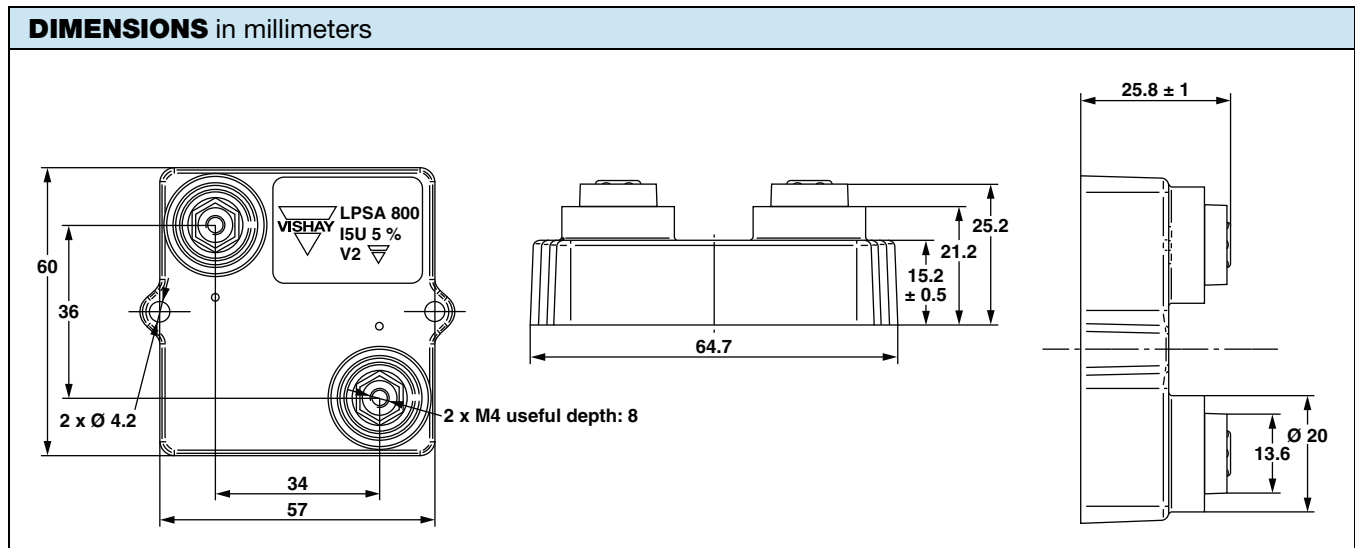
LPSA is a fully AEC-Q200 qualified high power resistor. Its high power / energy capability makes it a perfect fit for automotive precharge and discharge applications requiring high levels of performance.

Note

- Tolerances unless stated: ± 0.2 mm

STANDARD ELECTRICAL SPECIFICATIONS						
MODEL	RESISTANCE RANGE Ω	RATED POWER $P_{85^{\circ}\text{C}}$ W	LIMITING ELEMENT VOLTAGE U_L V	TOLERANCE ± %	TEMPERATURE COEFFICIENT ± ppm/°C	CRITICAL RESISTANCE (Ω)
LPSA 800	0.3 to 900K	800	5K	1, 2, 5, 10	150, 300, 500	31.25K



MECHANICAL SPECIFICATIONS	
Flammability	Insulated case UL 94 V-0
Resistive Element	Thick film
Substrate	Alumina
End Connections	Screws M4
Tightening Torque Connections	2 Nm
Tightening Torque Heatsink	2 Nm
Maximum Torque	2.5 Nm
Weight	83 g ± 10 %

ENVIRONMENTAL SPECIFICATIONS	
Temperature Range	-55 °C to +175 °C
Climatic Category	55 / 175 / 56

TECHNICAL SPECIFICATIONS	
Power Rating and Thermal Resistance	800 W at +85 °C bottom case temperature $R_{TH(j-c)}$: 0.112 °C/W
Temperature Coefficient -55 °C / +175 °C IEC 60115-1 Standard	$R \leq 1 \Omega$: ± 500 ppm/°C $1 \Omega < R \leq 10 \Omega$: ± 300 ppm/°C $10 \Omega < R$: ± 150 ppm/°C
Dielectric Strength IEC 60115-1, 1 min, 10 mA max.	7 kV _{RMS} or 12 kV _{RMS}
Lightning test 1.2/50 μs IEC 61000-4-5	Until 12 kV
Insulation Resistance	≥ 10 ⁴ MΩ
Inductance	≤ 0.1 μH
Partial Discharge (for LPSA 800 D only)	≤ 100 pC/7 kV ≤ 10 pC/5 kV Other cases: Consult us

PERFORMANCE		
TESTS	CONDITIONS	REQUIREMENTS
Momentary Overload	IEC 60115-1 1.5 x P _r /10 s $U_{max.} \leq U_L = 5000 V$	± (0.5 % + 0.005 Ω)
Load Life	IEC 60115-1 1000 h (90/30) P _r at 85 °C	± (0.5 % + 0.05 Ω)
High Temperature Exposure	AEC-Q200 rev. D conditions: MIL-STD-202 method 108 1000 h, +125 °C, unpowered	± (0.5 % + 0.005 Ω)
Temperature Cycling	AEC-Q200 rev. D conditions: JESD22 method JA-104 1000 cycles, -55 °C to +125 °C dwell time -15 min	± (1 % + 0.005 Ω)
Biased Humidity	AEC-Q200 rev. D conditions: MIL-STD-202 method 103 1000 h, +85 °C, 85 % RH	± (0.5 % + 0.005 Ω)
Operational Life	AEC-Q200 rev. D conditions: MIL-STD-202 method 108 1000 h, 90/30, powered, +25 °C	± (1 % + 0.005 Ω)
ESD Human Body Model	AEC-Q200 rev. D conditions: AEC-Q200-002 25 kV _{AD}	± (0.5 % + 0.005 Ω)
Vibration	AEC-Q200 rev. D conditions: MIL-STD-202 method 204 5 g for 20 min, 12 cycles test from 10 Hz to 2000 Hz	± (0.5 % + 0.005 Ω)
Mechanical Shock	AEC-Q200 rev. D conditions: MIL-STD-202 method 213 100 g; 6 ms, 3.75 m/s 3 shocks/direction	± (0.5 % + 0.005 Ω)
Terminal Strength	AEC-Q200 rev. D conditions: AEC-Q200-006 2.27 kg, 60 s	± (0.25 % + 0.01 Ω)



RECOMMENDATIONS FOR MOUNTING ONTO A HEATSINK

- Surfaces in contact must be carefully cleaned.
The heatsink must have an acceptable flatness: from 0.05 mm to 0.1 mm/100 mm.
Roughness of the heatsink must be around 6.3 μm. In order to improve thermal conductivity, surfaces in contact (alumina, heatsink) should be coated with a silicone grease (type Bluesil Past 340 from BlueStar Silicones) or a thermal film (type Q pad II) easier and faster to install than the grease.
The fastening of the resistor to the heatsink is under pressure control of two screws tightened at 2 Nm for full power availability.

Table with 2 columns: Tightening Torque on Heatsink, LPSA 800. Value: 2 Nm

- The following accessories are supplied with each product:
- 2 screws CHC M4 x 25 class 8.8 and 2 M4 contact lock washers for heatsink mounting
- 2 screws TH M4 x 6/6 and 2 M4 contact lock washers for connections.

CHOICE OF THE HEATSINK

The user must choose the heatsink according to the working conditions of the component (power, room temperature). Maximum working temperature must not exceed 175 °C. The dissipated power is simply calculated by the following ratio:

P = ΔT / (R_TH(j-c) + R_TH(c-h) + R_TH(h-a))

- P: expressed in W
ΔT: difference between maximum working temperature and room temperature
R_TH(j-c): thermal resistance value measured between resistive layer and outer side of the resistor. It is the thermal resistance of the component: (see specifications environmental paragraph).
R_TH(c-h): thermal resistance value measured between outer side of the resistor and upper side of the heatsink. This is the thermal resistance of the interface (grease, thermal pad), and the quality of the fastening device.
R_TH(h-a): thermal resistance of the heatsink.

Example:

R_TH(c-a) for LPSA 800 power dissipation 180 W at +50 °C room temperature.

ΔT ≤ 175 °C - 50 °C = 125 °C

R_TH(j-c) + R_TH(c-h) + R_TH(h-a) = ΔT / P = 125 / 180 = 0.69 °C/W

R_TH(j-c) = 0.112 °C/W

R_TH(c-h) + R_TH(h-a) = 0.69 °C/W - 0.112 °C/W = 0.578 °C/W

Table with 5 columns: CONFIG. 1: WATER COOLING HEATSINK CP15 AND THERMAL GREASE BLUESIL PAST 340, CONFIG. 2: AIR COOLING HEATSINK P207/250 AND THERMAL GREASE BLUESIL PAST 340, CONFIG. 3: WATER COOLING HEATSINK CP15 AND THERMAL PAD Q-PAD II, CONFIG. 4: AIR COOLING HEATSINK P207/250 AND THERMAL PAD Q-PAD II. Rows include Power dissipation (W), T° resistive element (°C), R_TH(j-c) max. (°C/W), R_TH(c-h) typ. (°C/W), R_TH(h-a) max. (°C/W), Fluid T° (°C).

Notes

- Configuration 1: Water cooling heatsink CP15 from Lytron (304 mm x 95.3 mm x 8 mm) with water flow rate 4 LPM and thermal grease Bluesil Past 340 from BlueStar silicones.
Configuration 2: Air cooling heatsink P207/250 from Semikron (250 mm x 200 mm x 72 mm) and thermal grease Bluesil Past 340 from BlueStar silicones.
Configuration 3: Water cooling heatsink CP15 from Lytron (304 mm x 95.3 mm x 8 mm) with water flow rate 4 LPM and thermal pad Q-Pad II from Berquist.
Configuration 4: Air cooling heatsink P207/250 from Semikron (250 mm x 200 mm x 72 mm) and thermal pad Q-Pad II from Berquist.

OVERLOADS

In any case the applied voltage must be lower than U_L = 5000 V.

Short time overload: 1.5 x P_r/10 s

Accidental overload: The values indicated on the following graph are applicable to resistors in air or mounted onto a heatsink.



ENERGY CURVE

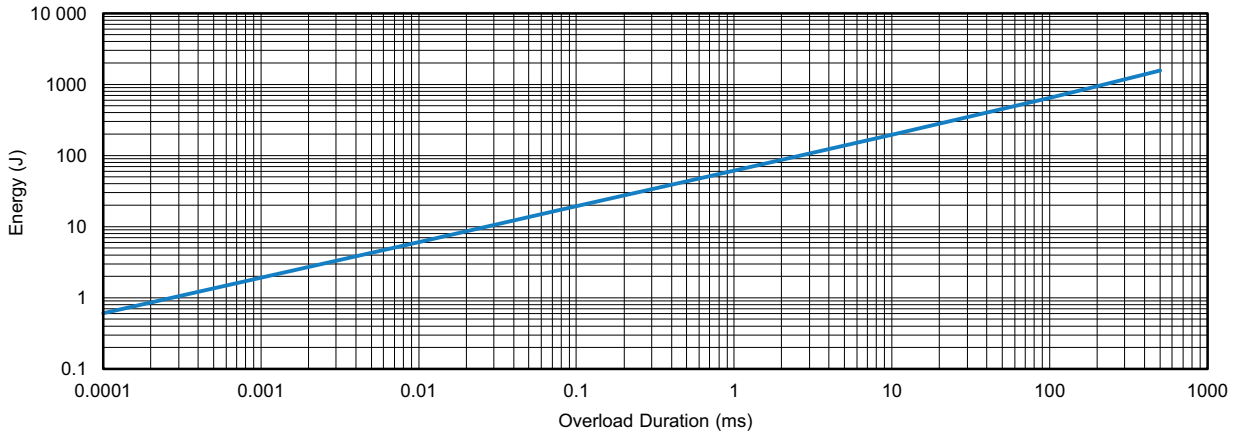

POWER CURVE

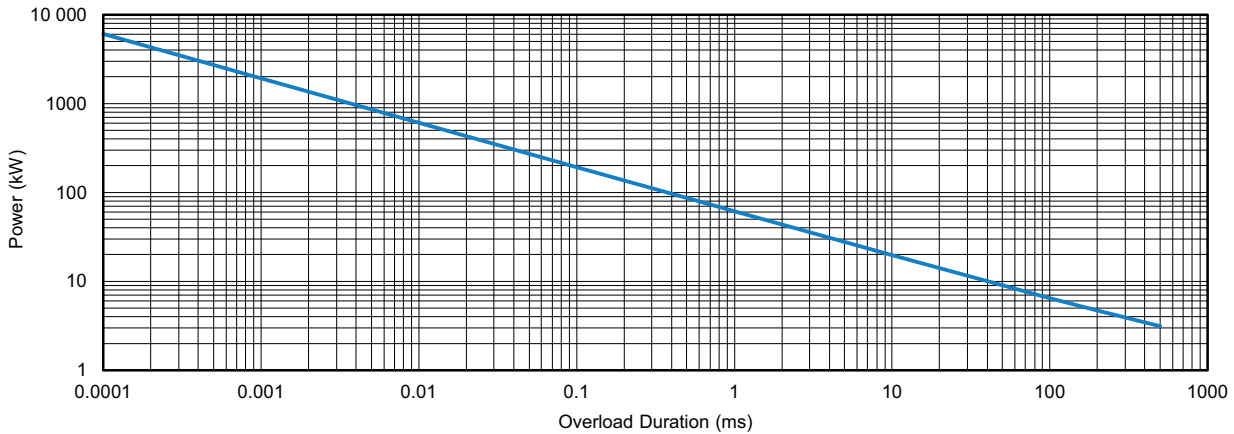

POWER RATING

The temperature of the case should be maintained within the limits specified in the following figure. To optimize the thermal conduction, contacting surfaces should be coated with silicone grease or thermal film, and heatsink mounting screws tightened to 2 Nm.

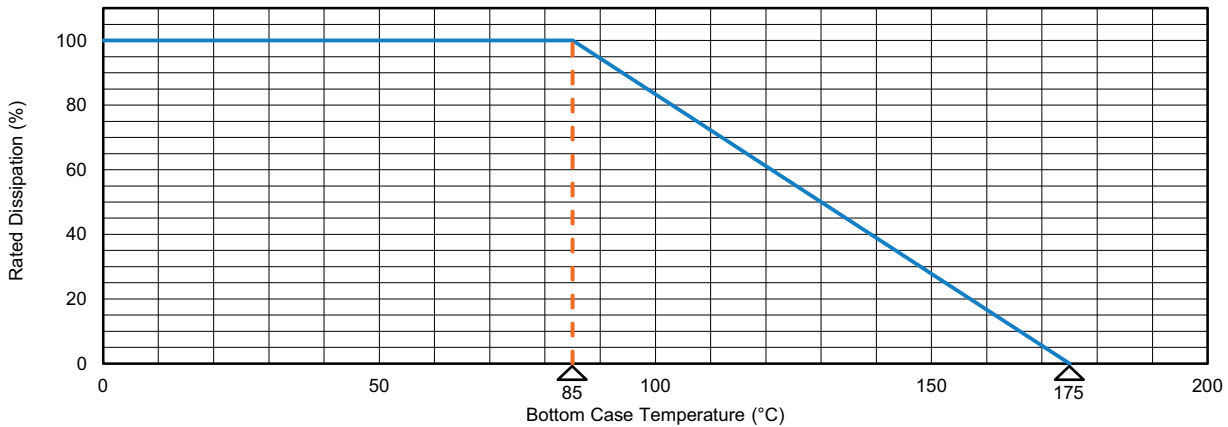



MARKING

Series, style, ohmic value (in Ω), tolerance (in %), manufacturing date, Vishay Sfernice trademark.

PACKAGING
Box of 15 units

ORDERING INFORMATION						
LPSA	800	100 kΩ	± 1 %	xxx	BO15	e
MODEL	STYLE	RESISTANCE VALUE	TOLERANCE	CUSTOM DESIGN	PACKAGING	LEAD (Pb)-FREE
			± 1 % ± 2 % ± 5 % ± 10 %	Optional on request: special TCR, shape etc.		

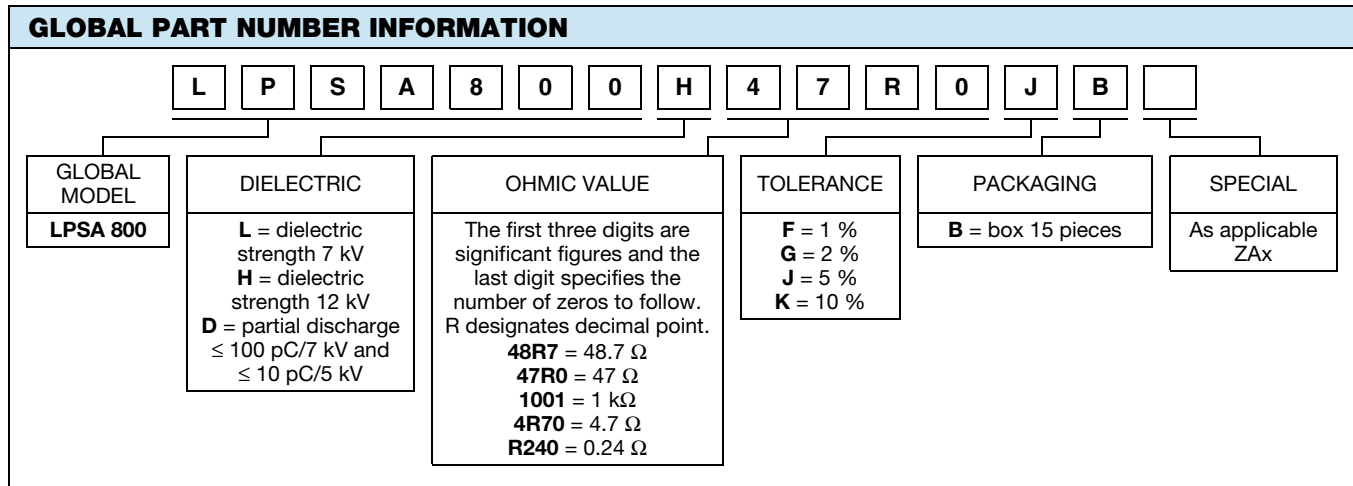



Disclaimer

ALL PRODUCT, PRODUCT SPECIFICATIONS AND DATA ARE SUBJECT TO CHANGE WITHOUT NOTICE TO IMPROVE RELIABILITY, FUNCTION OR DESIGN OR OTHERWISE.

Vishay Intertechnology, Inc., its affiliates, agents, and employees, and all persons acting on its or their behalf (collectively, "Vishay"), disclaim any and all liability for any errors, inaccuracies or incompleteness contained in any datasheet or in any other disclosure relating to any product.

Vishay makes no warranty, representation or guarantee regarding the suitability of the products for any particular purpose or the continuing production of any product. To the maximum extent permitted by applicable law, Vishay disclaims (i) any and all liability arising out of the application or use of any product, (ii) any and all liability, including without limitation special, consequential or incidental damages, and (iii) any and all implied warranties, including warranties of fitness for particular purpose, non-infringement and merchantability.

Statements regarding the suitability of products for certain types of applications are based on Vishay's knowledge of typical requirements that are often placed on Vishay products in generic applications. Such statements are not binding statements about the suitability of products for a particular application. It is the customer's responsibility to validate that a particular product with the properties described in the product specification is suitable for use in a particular application. Parameters provided in datasheets and / or specifications may vary in different applications and performance may vary over time. All operating parameters, including typical parameters, must be validated for each customer application by the customer's technical experts. Product specifications do not expand or otherwise modify Vishay's terms and conditions of purchase, including but not limited to the warranty expressed therein.

Hyperlinks included in this datasheet may direct users to third-party websites. These links are provided as a convenience and for informational purposes only. Inclusion of these hyperlinks does not constitute an endorsement or an approval by Vishay of any of the products, services or opinions of the corporation, organization or individual associated with the third-party website. Vishay disclaims any and all liability and bears no responsibility for the accuracy, legality or content of the third-party website or for that of subsequent links.

Vishay products are not designed for use in life-saving or life-sustaining applications or any application in which the failure of the Vishay product could result in personal injury or death unless specifically qualified in writing by Vishay. Customers using or selling Vishay products not expressly indicated for use in such applications do so at their own risk. Please contact authorized Vishay personnel to obtain written terms and conditions regarding products designed for such applications.

No license, express or implied, by estoppel or otherwise, to any intellectual property rights is granted by this document or by any conduct of Vishay. Product names and markings noted herein may be trademarks of their respective owners.