



Part Number : [1200750015](#)

Product Description : Micro-Change (M12)
Dual Keyway with PG9 Cable Fitting, Straight
Female, 3 Poles, Cable Diameter 4.10-8.10mm

Series Number : 120075

Status : Active

Product Category : Circular Industrial
Connectors

Engineering Number : 7A3000-32

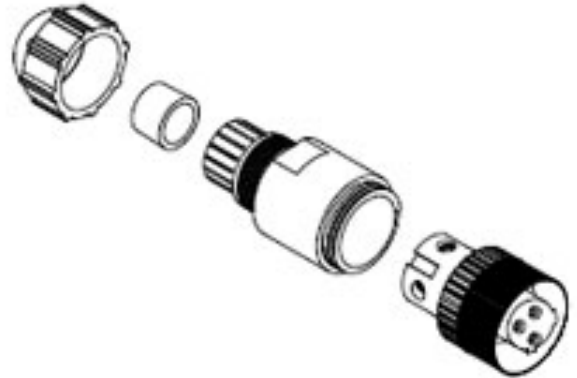

Documents & Resources

Drawings

[1200750015_sd.pdf](#)

Product Environment Compliance

Compliance

GADSL/IMDS	Not Relevant
China RoHS	Not Reviewed per SJ/T 11365-2006
EU ELV	Not Relevant
Low-Halogen Status	Not Reviewed per IEC 61249-2-21
REACH SVHC	Not Reviewed per D(2024)6225-DC (07 Nov 2024)
EU RoHS	Not Reviewed per EU 2015/863

Multiple Part Product Compliance Statements

- Eu RoHS
- REACH SVHC
- Low-Halogen

Multiple Part Industry Compliance Documents

- IPC 1752A Class C
- IPC 1752A Class D
- Molex Product Compliance Declaration
- IEC-62474
- chemSHERPA (xml)

Part Details

General

Status	Active
Category	Circular Industrial Connectors
Series	120075
Description	Micro-Change (M12) Dual Keyway with PG9 Cable Fitting, Straight Female, 3 Poles, Cable Diameter 4.10-8.10mm
IP Rating	IP67
Product Name	Micro-Change (1/2" - 20 UNF)
Type	Field Attachable Connector
UPC	78678830716

Electrical

Current - Maximum per Contact	4.0A
Voltage - Maximum	250V AC / 300V DC

Physical

Cable Diameter	4.10-8.10mm (.161-.319")
Coupling Type	Internal Thread
Diagnostics / LEDs	No
Diagnostics Port	No
Gender	Female
Keyway	Dual
Material - Connector Body	PA
Material - Contact	Brass
Material - Coupling Nut	Nickel-plated Brass
Material - Plating Mating	Gold
Orientation	Straight
Poles	3
Temperature Range - Operating	-25°C to +90°C
Wire Size (AWG)	18

This document was generated on Feb 13, 2025