

TPS92543-Q1 65V Automotive Synchronous BOOST Controller, 2A Synchronous CC BUCK and Bypass FET Controllers

1 Features

- AEC-Q100 qualified for automotive applications
 - Grade 1: –40°C to 125°C ambient operating temperature
 - Device HBM classification level H1C
 - Device CDM classification level C5
- [Functional Safety-Capable](#)
 - Documentation available to aid functional safety system design
- 4.5V to 65V wide input voltage range
- Synchronous Buck with integrated switches
 - Up to 2A continuous output current with 4% accuracy
- Synchronous BOOST controller
 - Programmable output voltage up to 65V
- Six floating gate drivers for shunt-FET dimming
 - Programmable width and phase setting
 - Programmable PWM frequency
- BOOST and BUCK spread-spectrum for EMI mitigation
- BUCK switch thermal protection
- UART serial communication
 - Internal oscillator for system clock
 - LMM compatible
- Internal EEPROM
 - Default settings
 - Customer calibration data

2 Applications

- [Automotive headlight and adaptive LED driving module](#)

3 Description

The TPS92543 device contains a synchronous BOOST controller and a monolithic synchronous buck LED driver with a wide 4.5V to 65V operating BUCK input voltage range. The TPS92543 includes two sub-strings of three series connected floating bypass FET controllers.

The synchronous BOOST controller implements a peak current-mode controller to operate in constant voltage mode. The Boost can be programmed to operate as dual-phase together with another TPS92543. The output voltage can be programmed using a programmable 8-bit DAC.

The monolithic synchronous BUCK implements an adaptive on-time average current mode control and

is designed to be compatible with shunt FET dimming techniques and LED matrix manager-based dynamic beam headlamps. The adaptive on-time control provides near constant switching frequency that can be set between 100kHz and 1.0MHz. Inductor current sensing and closed-loop feedback enable better than ±4% accuracy over wide input voltage, output voltage and ambient temperature range.

The TPS92543 incorporates two sub-strings of three series connected floating bypass FET controllers to perform LED shunt FET dimming. Each controller can perform FET dimming with segment voltages of up to 55V. The device includes programmable registers for phase shift and pulse width of each individual segment.

The TPS92543 includes an internal oscillator. The UART serial interface is compatible with TPS9266x, and TPS9254x devices. The internal EEPROM can store system defaults as well as calibration and lighting module data. The four configurable MPIOs can be configured as digital inputs or outputs, or ADC input for use with system temperature compensation, LED binning and coding.

The TPS92543-Q1 is available in a 7.0mm × 7.0mm thermally-enhanced 48-pin HTQFP package with top-exposed pad.

Device Information

PART NUMBER ⁽¹⁾	PACKAGE	BODY SIZE (NOM)
TPS92543-Q1	PKD (HTQFP, 48)	7.0mm × 7.0mm

(1) For all available packages, see the orderable addendum at the end of the data sheet.

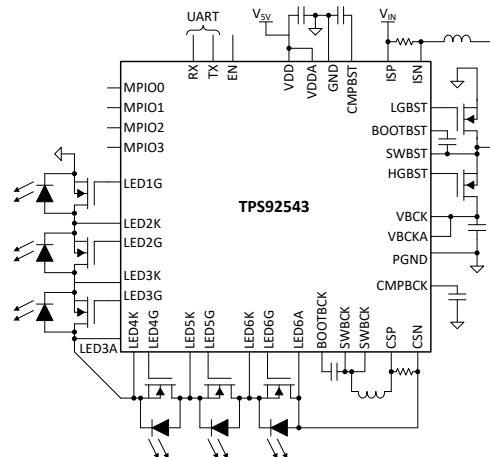

Simplified Schematic

Table of Contents

1 Features	1	5.3 Trademarks.....	5
2 Applications	1	5.4 Glossary.....	5
3 Description	1	6 Revision History	5
4 Pin Configuration and Functions	3	7 Mechanical, Packaging, and Orderable Information	5
5 Device and Documentation Support	5	7.1 Package Option Addendum.....	6
5.1 Receiving Notification of Documentation Updates.....	5	7.2 Tape and Reel Information.....	7
5.2 Support Resources.....	5		

4 Pin Configuration and Functions

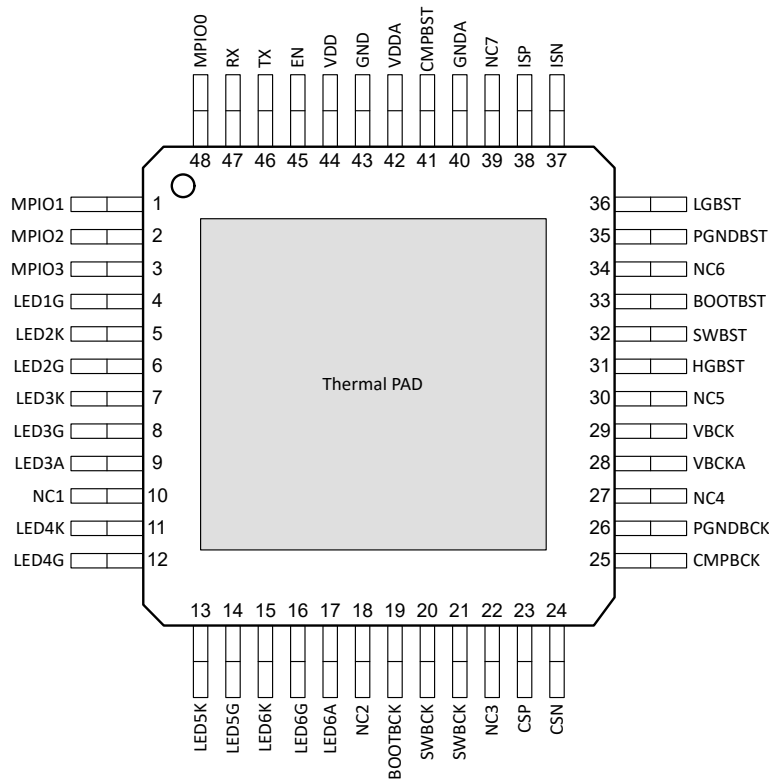

Figure 4-1. PKD Package 48-Pin HTQFP (Top-Exposed PAD) Top View

Table 4-1. Pin Functions

PIN		I/O	DESCRIPTION
NAME	NO. PKD		
BOOTBCK	19	P	Supply input for BUCK high-side MOSFET gate drive circuit. Connect a ceramic capacitor between BOOTBCK and SWBCK pins. An internal diode is connected between VDD and BOOTBCK.
BOOTBST	33	P	Supply input for BOOST high-side MOSFET gate drive circuit. Connect a ceramic capacitor between BOOTBST and SWBST pins. An internal diode is connected between VDD and BOOTBST.
CMPBCK	25	I/O	Output of BUCK internal transconductance error amplifier. Connect an integral compensation network to ensure stability.
CMPBST	41	I/O	Output of BOOST internal transconductance error amplifier. Connect a proportional-integral compensation network to ensure stability.
CSN	24	I	Negative input (–) of internal rail-to-rail transconductance error amplifier. Connect directly to the negative node of the LED current sense resistor, R_{CS} .
CSP	23	I	Positive input (+) of internal rail-to-rail transconductance error amplifier. Connect directly to the positive node of the LED current sense resistor, R_{CS} .
EN	45	I	Hardware enable. Pull this pin low to enter shutdown.
GND	43	G	Signal and analog ground. Return for the internal voltage reference and analog circuits. Connect to circuit ground to complete return path.
GNDA	40		
HGBST	31	I/O	BOOST high side gate driver output.
ISN	37	O	Negative input (–) of BOOST current sense amplifier. Connect directly to the current sense resistor, R_{IS} .

Table 4-1. Pin Functions (continued)

PIN		I/O	DESCRIPTION
NAME	NO. PKD		
ISP	38	I	Positive input (+) of BOOST current sense amplifier. Connect directly to the current sense resistor, R_{IS} .
LGBST	36	I/O	BOOST low side gate driver output.
LED1G	4	I/O	Gate driver output for external shunt FET controller. Connect to the gate of the external FET
LED2G	6	I/O	
LED3G	8	I/O	
LED4G	12	I/O	
LED5G	14	I/O	
LED6G	16	I/O	
LED3A	9	I/O	
LED6A	17	I/O	Connect to anode of the LED6 (top of the sub-string 1)
LED2K	5	I/O	Connect to cathode of the LED2
LED3K	7	I/O	Connect to cathode of the LED3
LED4K	11	I/O	Connect to cathode of the LED4
LED5K	13	I/O	Connect to cathode of the LED5
LED6K	15	I/O	Connect to cathode of the LED6
MPIO0	48	I/O	Multi-purpose IO. The pin can be configured as an ADC input, digital input, or digital output. MPIO0 is used to enter CTM.
MPIO1	1	I/O	Multi-purpose IO. The pin can be configured as an ADC input, digital input, or digital output
MPIO2	2	I/O	
MPIO3	3	I/O	
NC1, NC2, NC3, NC4, NC5, NC6, NC7	10, 18, 22, 27, 30, 34, 39	NC	Do not connect. Can be connected to ground.
PGNDBCK	26	G	Ground return for BUCK low-side MOSFET
PGNDBST	35	G	Ground return for BOOST high-side gate driver
RX	47	I	UART receive data input. Connect to RX of CAN transceiver.
SWBCK	20, 21	P	Switching output of the BUCK regulator. Internally connected to both power MOSFETs. Connect to the power inductor.
SWBST	32	P	Switch node of the BOOST controller.
TX	46	O	UART transmit data output. Connect to TX of CAN transceiver.
VBCK	29	P	Power input and connections to BUCK high-side MOSFET drain node. Connect to the BOOST output voltage and bypass capacitors C_{IN} . The path from the VBCK pin to high frequency bypass C_{IN} and PGND must be as short as possible.
VBCKA	28	P	Power to internal analog block of BUCK regulator. Connect to VBCK pin and high frequency bypass capacitor.
VDD	44	P	Digital input supply voltage. Locally decouple to GND using a 2.2 μ F to 4.7 μ F ceramic capacitor located close to the device.
VDDA	42	P	Analog input supply voltage. Locally decouple to GND using a 100nF to 1 μ F ceramic capacitor located close to the device.

5 Device and Documentation Support

5.1 Receiving Notification of Documentation Updates

To receive notification of documentation updates, navigate to the device product folder on ti.com. In the upper right corner, click on *Alert me* to register and receive a weekly digest of any product information that has changed. For change details, review the revision history included in any revised document.

5.2 Support Resources

[TI E2E™ support forums](#) are an engineer's go-to source for fast, verified answers and design help — straight from the experts. Search existing answers or ask your own question to get the quick design help you need.

Linked content is provided "AS IS" by the respective contributors. They do not constitute TI specifications and do not necessarily reflect TI's views; see TI's [Terms of Use](#).

5.3 Trademarks

TI E2E™ is a trademark of Texas Instruments.
All trademarks are the property of their respective owners.

5.4 Glossary

[TI Glossary](#) This glossary lists and explains terms, acronyms, and definitions.

6 Revision History

NOTE: Page numbers for previous revisions may differ from page numbers in the current version.

DATE	REVISION	NOTES
November 2024	*	Initial release

7 Mechanical, Packaging, and Orderable Information

The following pages include mechanical, packaging, and orderable information. This information is the most current data available for the designated devices. This data is subject to change without notice and revision of this document. For browser-based versions of this data sheet, refer to the left-hand navigation.

7.1 Package Option Addendum

Packaging Information

Orderable Device	Status ⁽¹⁾	Package Type	Package Drawing	Pins	Package Qty	Eco Plan ⁽²⁾	Lead/Ball Finish ⁽⁴⁾	MSL Peak Temp ⁽³⁾	Op Temp (°C)	Device Marking ^{(5) (6)}
TPS92543QPKDRQ1	PREVIEW	HTQFP	PKD	48	1000	Green (RoHS and no Sb/Br)	NIPDAU	LEVEL3-260C-168 HR	-40 to 125	TPS92543

- (1) The marketing status values are defined as follows:
ACTIVE: Product device recommended for new designs.
LIFEBUY: TI has announced that the device will be discontinued, and a lifetime-buy period is in effect.
NRND: Not recommended for new designs. Device is in production to support existing customers, but TI does not recommend using this part in a new design.
PRE_PROD Unannounced device, not in production, not available for mass market, nor on the web, samples not available.
PREVIEW: Device has been announced but is not in production. Samples may or may not be available.
OBSOLETE: TI has discontinued the production of the device.
- (2) Eco Plan - The planned eco-friendly classification: Pb-Free (RoHS), Pb-Free (RoHS Exempt), or Green (RoHS & no Sb/Br) - please check <http://www.ti.com/productcontent> for the latest availability information and additional product content details.
TBD: The Pb-Free/Green conversion plan has not been defined.
Pb-Free (RoHS): TI's terms "Lead-Free" or "Pb-Free" mean semiconductor products that are compatible with the current RoHS requirements for all 6 substances, including the requirement that lead not exceed 0.1% by weight in homogeneous materials. Where designed to be soldered at high temperatures, TI Pb-Free products are suitable for use in specified lead-free processes.
Pb-Free (RoHS Exempt): This component has a RoHS exemption for either 1) lead-based flip-chip solder bumps used between the die and package, or 2) lead-based die adhesive used between the die and leadframe. The component is otherwise considered Pb-Free (RoHS compatible) as defined above.
Green (RoHS & no Sb/Br): TI defines "Green" to mean Pb-Free (RoHS compatible), and free of Bromine (Br) and Antimony (Sb) based flame retardants (Br or Sb do not exceed 0.1% by weight in homogeneous material)
- (3) MSL, Peak Temp. -- The Moisture Sensitivity Level rating according to the JEDEC industry standard classifications, and peak solder temperature.
- (4) Lead/Ball Finish - Orderable Devices may have multiple material finish options. Finish options are separated by a vertical ruled line. Lead/Ball Finish values may wrap to two lines if the finish value exceeds the maximum column width.
- (5) There may be additional marking, which relates to the logo, the lot trace code information, or the environmental category on the device
- (6) Multiple Device markings will be inside parentheses. Only one Device Marking contained in parentheses and separated by a "~" will appear on a device. If a line is indented then it is a continuation of the previous line and the two combined represent the entire Device Marking for that device.
Important Information and Disclaimer: The information provided on this page represents TI's knowledge and belief as of the date that it is provided. TI bases its knowledge and belief on information provided by third parties, and makes no representation or warranty as to the accuracy of such information. Efforts are underway to better integrate information from third parties. TI has taken and continues to take reasonable steps to provide representative and accurate information but may not have conducted destructive testing or chemical analysis on incoming materials and chemicals. TI and TI suppliers consider certain information to be proprietary, and thus CAS numbers and other limited information may not be available for release.
 In no event shall TI's liability arising out of such information exceed the total purchase price of the TI part(s) at issue in this document sold by TI to Customer on an annual basis.

7.2 Tape and Reel Information

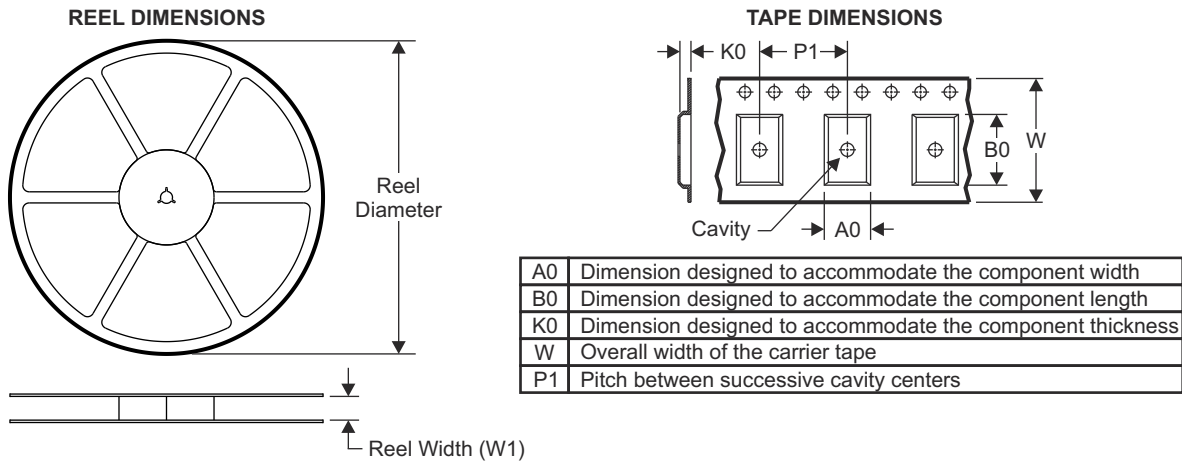

QUADRANT ASSIGNMENTS FOR PIN 1 ORIENTATION IN TAPE

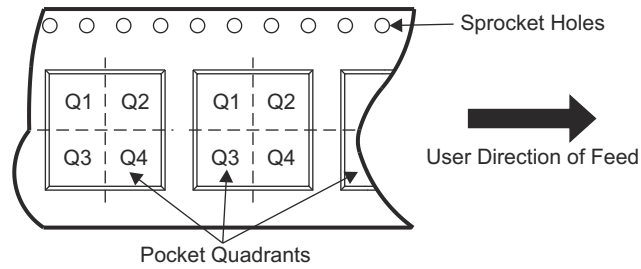

Device	Package Type	Package Drawing	Pins	SPQ	Reel Diameter (mm)	Reel Width W1 (mm)	A0 (mm)	B0 (mm)	K0 (mm)	P1 (mm)	W (mm)	Pin1 Quadrant
TPS92543QPKDRQ1	HTQFP	PKD	48	1000	330	16.4	9.6	9.6	1.5	12	16	Q2

TAPE AND REEL BOX DIMENSIONS

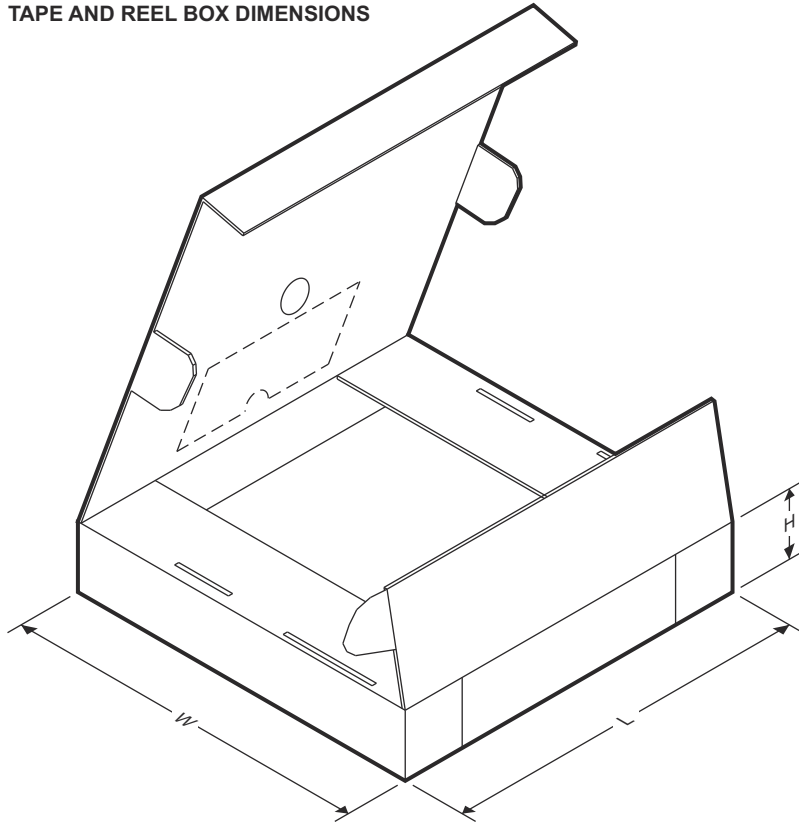

Device	Package Type	Package Drawing	Pins	SPQ	Length (mm)	Width (mm)	Height (mm)
TPS92543QPKDRQ1	HTQFP	PKD	48	1000	336.6	336.6	31.8

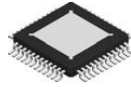

PACKAGE OUTLINE

PKD0048A

PowerPAD™ HTQFP - 1.15 mm max height

PLASTIC QUAD FLATPACK

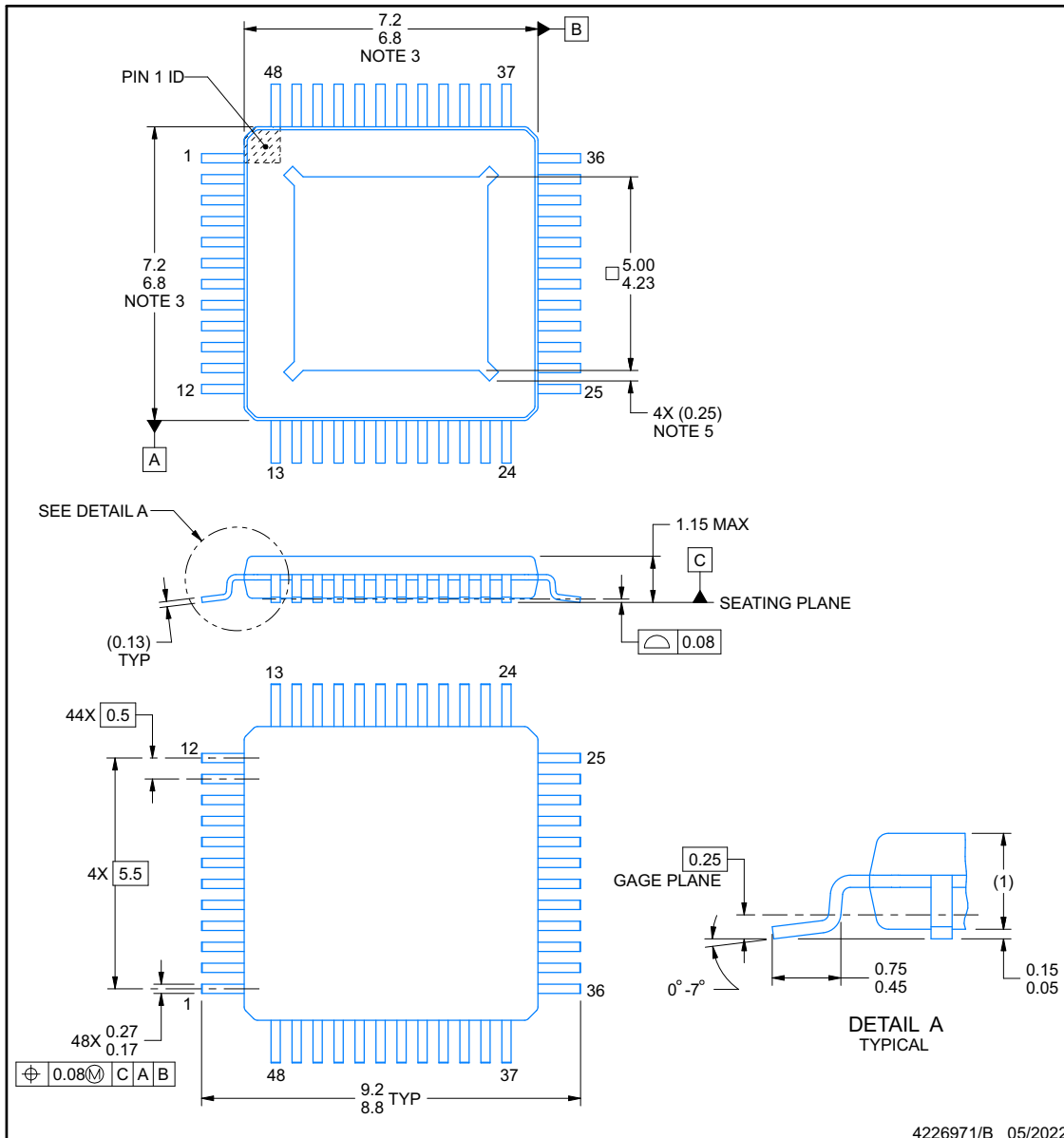

NOTES:

PowerPAD is a trademark of Texas Instruments.

1. All linear dimensions are in millimeters. Any dimensions in parenthesis are for reference only. Dimensioning and tolerancing per ASME Y14.5M.
2. This drawing is subject to change without notice.
3. This dimension does not include mold flash, protrusions, or gate burrs. Mold flash, protrusions, or gate burrs shall not exceed 0.15 mm per side.
4. Reference JEDEC registration MS-026.
5. Feature may not be present.

EXAMPLE STENCIL DESIGN

PKD0048A

PowerPAD™ HTQFP - 1.15 mm max height

PLASTIC QUAD FLATPACK

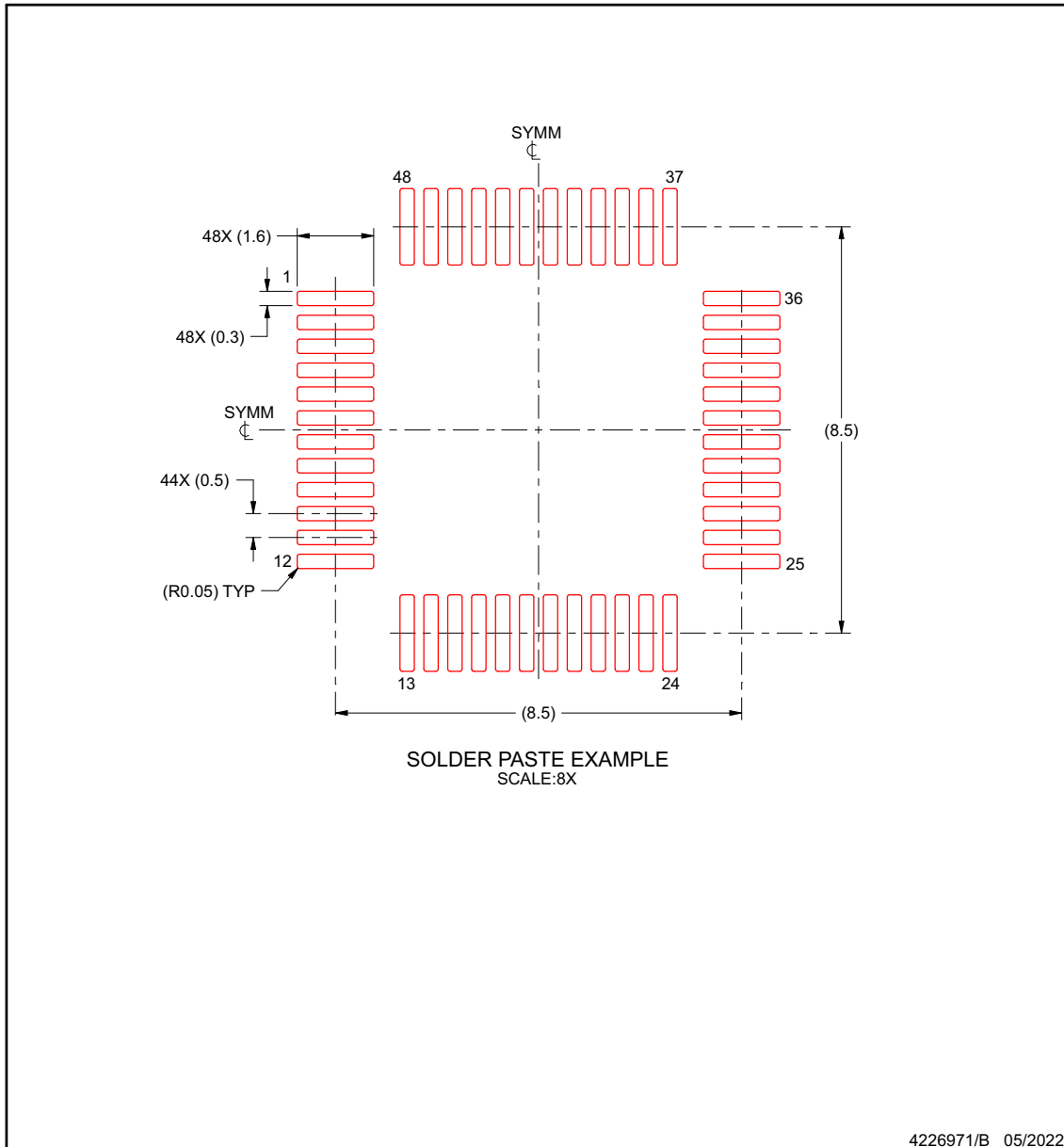

NOTES: (continued)

11. Laser cutting apertures with trapezoidal walls and rounded corners may offer better paste release. IPC-7525 may have alternate design recommendations.
12. Board assembly site may have different recommendations for stencil design.

PACKAGING INFORMATION

Orderable Device	Status (1)	Package Type	Package Drawing	Pins	Package Qty	Eco Plan (2)	Lead finish/ Ball material (6)	MSL Peak Temp (3)	Op Temp (°C)	Device Marking (4/5)	Samples
TPS92543QPKDRQ1	ACTIVE	HTQFP	PKD	48	1000	RoHS & Green	NIPDAU	Level-3-260C-168 HR	-40 to 125	TPS92543	Samples

(1) The marketing status values are defined as follows:

ACTIVE: Product device recommended for new designs.

LIFEBUY: TI has announced that the device will be discontinued, and a lifetime-buy period is in effect.

NRND: Not recommended for new designs. Device is in production to support existing customers, but TI does not recommend using this part in a new design.

PREVIEW: Device has been announced but is not in production. Samples may or may not be available.

OBSELETE: TI has discontinued the production of the device.

(2) **RoHS:** TI defines "RoHS" to mean semiconductor products that are compliant with the current EU RoHS requirements for all 10 RoHS substances, including the requirement that RoHS substance do not exceed 0.1% by weight in homogeneous materials. Where designed to be soldered at high temperatures, "RoHS" products are suitable for use in specified lead-free processes. TI may reference these types of products as "Pb-Free".

RoHS Exempt: TI defines "RoHS Exempt" to mean products that contain lead but are compliant with EU RoHS pursuant to a specific EU RoHS exemption.

Green: TI defines "Green" to mean the content of Chlorine (Cl) and Bromine (Br) based flame retardants meet JS709B low halogen requirements of <=1000ppm threshold. Antimony trioxide based flame retardants must also meet the <=1000ppm threshold requirement.

(3) MSL, Peak Temp. - The Moisture Sensitivity Level rating according to the JEDEC industry standard classifications, and peak solder temperature.

(4) There may be additional marking, which relates to the logo, the lot trace code information, or the environmental category on the device.

(5) Multiple Device Markings will be inside parentheses. Only one Device Marking contained in parentheses and separated by a "-" will appear on a device. If a line is indented then it is a continuation of the previous line and the two combined represent the entire Device Marking for that device.

(6) Lead finish/Ball material - Orderable Devices may have multiple material finish options. Finish options are separated by a vertical ruled line. Lead finish/Ball material values may wrap to two lines if the finish value exceeds the maximum column width.

Important Information and Disclaimer:The information provided on this page represents TI's knowledge and belief as of the date that it is provided. TI bases its knowledge and belief on information provided by third parties, and makes no representation or warranty as to the accuracy of such information. Efforts are underway to better integrate information from third parties. TI has taken and continues to take reasonable steps to provide representative and accurate information but may not have conducted destructive testing or chemical analysis on incoming materials and chemicals. TI and TI suppliers consider certain information to be proprietary, and thus CAS numbers and other limited information may not be available for release.

In no event shall TI's liability arising out of such information exceed the total purchase price of the TI part(s) at issue in this document sold by TI to Customer on an annual basis.

TAPE AND REEL INFORMATION

QUADRANT ASSIGNMENTS FOR PIN 1 ORIENTATION IN TAPE

*All dimensions are nominal

Device	Package Type	Package Drawing	Pins	SPQ	Reel Diameter (mm)	Reel Width W1 (mm)	A0 (mm)	B0 (mm)	K0 (mm)	P1 (mm)	W (mm)	Pin1 Quadrant
TPS92543QPKDRQ1	HTQFP	PKD	48	1000	330.0	16.4	9.6	9.6	1.5	12.0	16.0	Q2

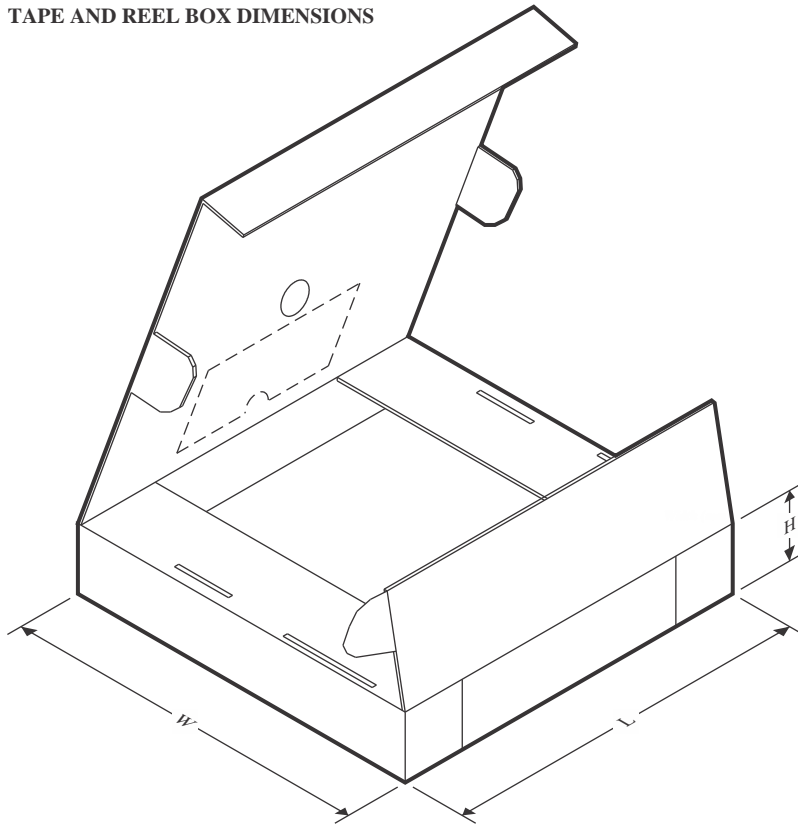
TAPE AND REEL BOX DIMENSIONS

*All dimensions are nominal

Device	Package Type	Package Drawing	Pins	SPQ	Length (mm)	Width (mm)	Height (mm)
TPS92543QPKDRQ1	HTQFP	PKD	48	1000	336.6	336.6	31.8

GENERIC PACKAGE VIEW

PKD 48

PowerPAD™ HTQFP - 1.15 mm max height

7 x 7, 0.5 mm pitch

PLASTIC QUAD FLATPACK

This image is a representation of the package family, actual package may vary.
Refer to the product data sheet for package details.

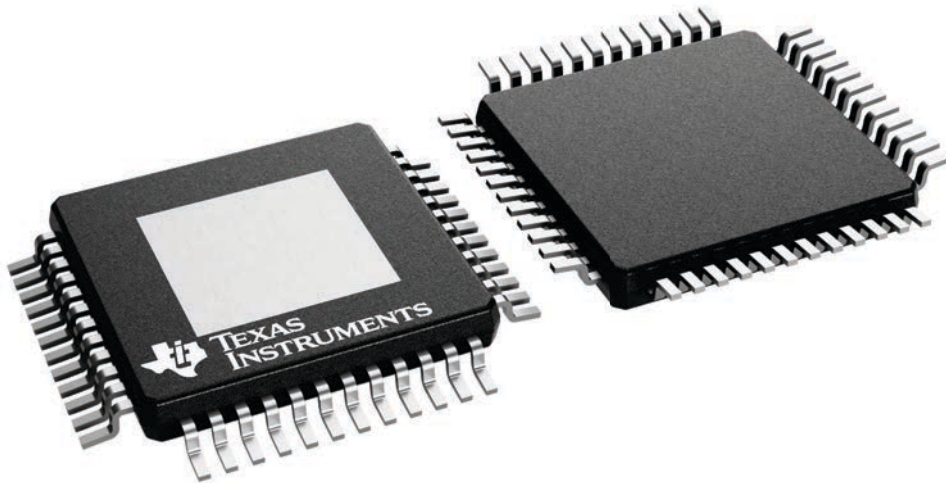

4231748/A

PKD0048A

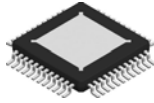

PACKAGE OUTLINE
PowerPAD™ HTQFP - 1.15 mm max height

PLASTIC QUAD FLATPACK

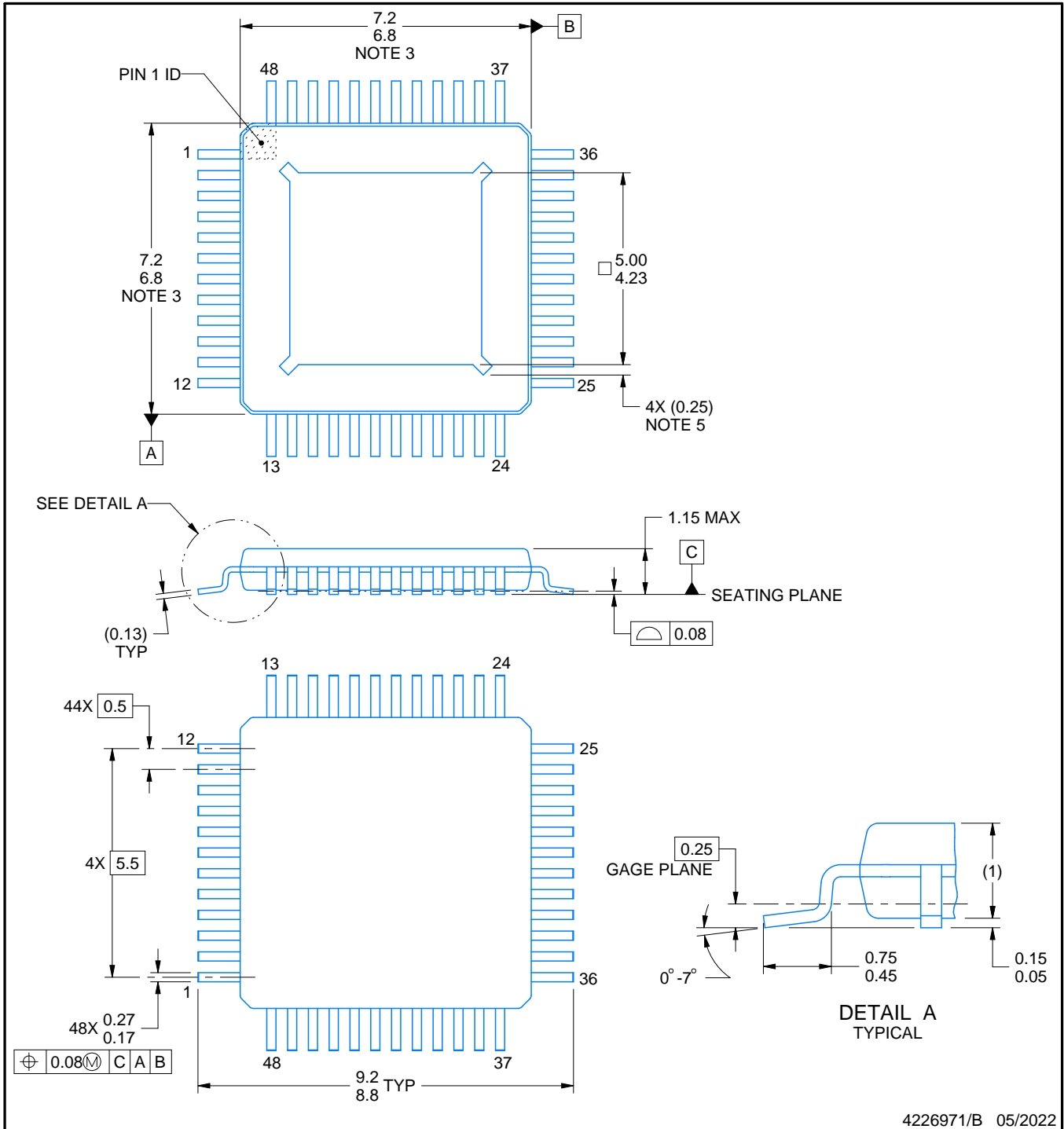

NOTES:

PowerPAD is a trademark of Texas Instruments.

1. All linear dimensions are in millimeters. Any dimensions in parenthesis are for reference only. Dimensioning and tolerancing per ASME Y14.5M.
2. This drawing is subject to change without notice.
3. This dimension does not include mold flash, protrusions, or gate burrs. Mold flash, protrusions, or gate burrs shall not exceed 0.15 mm per side.
4. Reference JEDEC registration MS-026.
5. Feature may not be present.

EXAMPLE BOARD LAYOUT

PKD0048A

PowerPAD™ HTQFP - 1.15 mm max height

PLASTIC QUAD FLATPACK

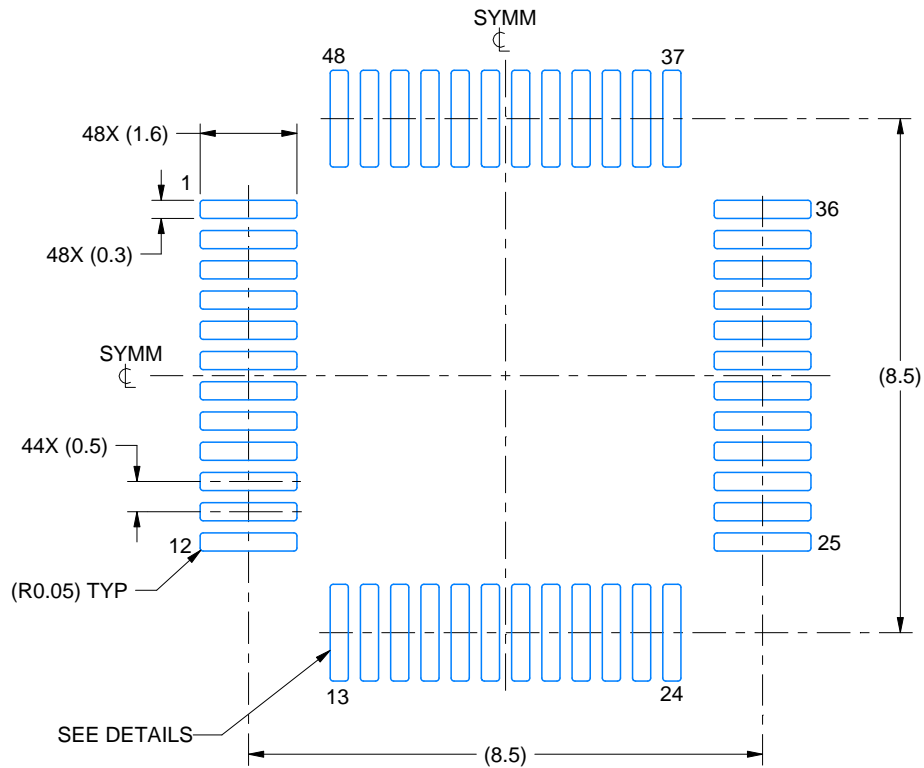

LAND PATTERN EXAMPLE
EXPOSED METAL SHOWN
SCALE:8X

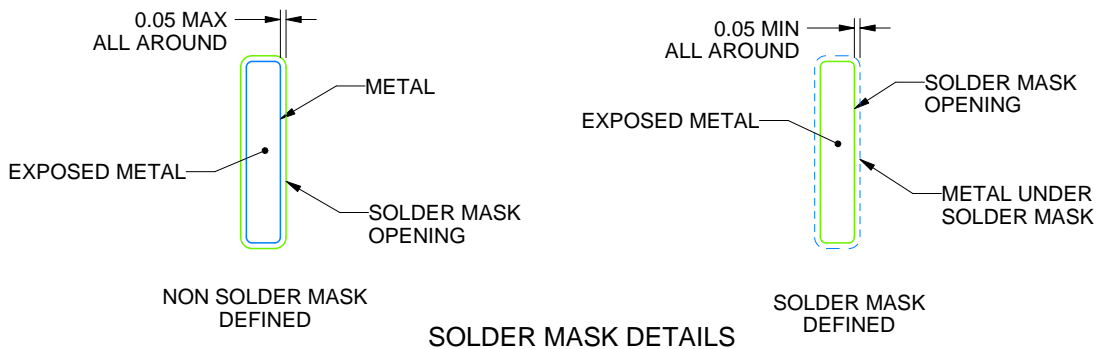

4226971/B 05/2022

NOTES: (continued)

6. Publication IPC-7351 may have alternate designs.
7. Solder mask tolerances between and around signal pads can vary based on board fabrication site.
8. This package is designed to be soldered to a thermal pad on the board. See technical brief, Powerpad thermally enhanced package, Texas Instruments Literature No. SLMA002 (www.ti.com/lit/slma002) and SLMA004 (www.ti.com/lit/slma004).
9. Vias are optional depending on application, refer to device data sheet. It is recommended that vias under paste be filled, plugged or tented.
10. Size of metal pad may vary due to creepage requirement.

EXAMPLE STENCIL DESIGN

PKD0048A

PowerPAD™ HTQFP - 1.15 mm max height

PLASTIC QUAD FLATPACK

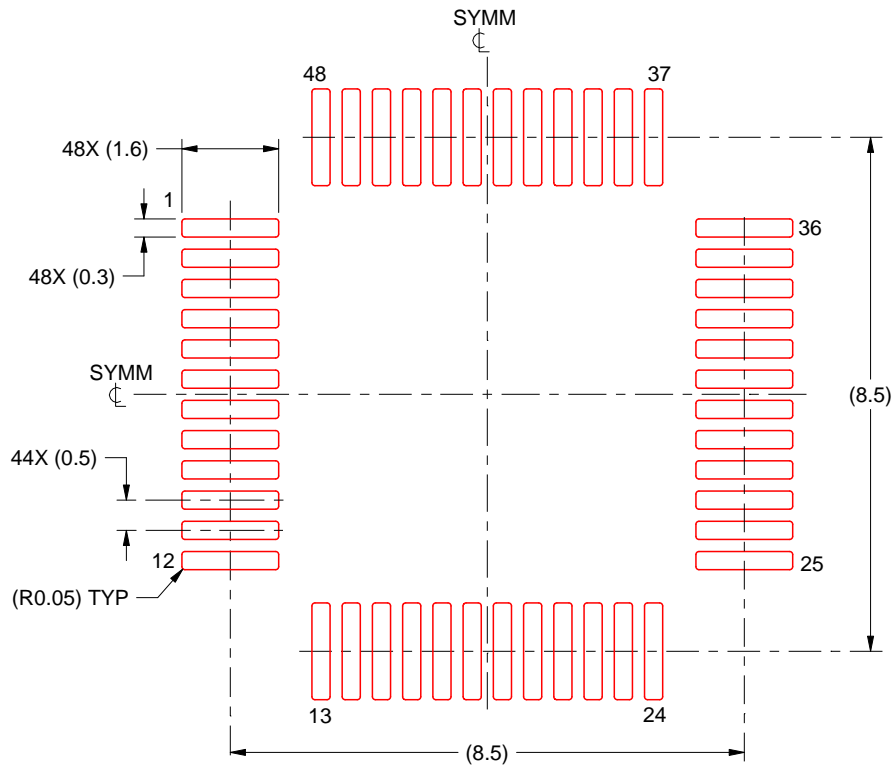

SOLDER PASTE EXAMPLE
SCALE:8X

4226971/B 05/2022

NOTES: (continued)

11. Laser cutting apertures with trapezoidal walls and rounded corners may offer better paste release. IPC-7525 may have alternate design recommendations.
12. Board assembly site may have different recommendations for stencil design.

IMPORTANT NOTICE AND DISCLAIMER

TI PROVIDES TECHNICAL AND RELIABILITY DATA (INCLUDING DATA SHEETS), DESIGN RESOURCES (INCLUDING REFERENCE DESIGNS), APPLICATION OR OTHER DESIGN ADVICE, WEB TOOLS, SAFETY INFORMATION, AND OTHER RESOURCES "AS IS" AND WITH ALL FAULTS, AND DISCLAIMS ALL WARRANTIES, EXPRESS AND IMPLIED, INCLUDING WITHOUT LIMITATION ANY IMPLIED WARRANTIES OF MERCHANTABILITY, FITNESS FOR A PARTICULAR PURPOSE OR NON-INFRINGEMENT OF THIRD PARTY INTELLECTUAL PROPERTY RIGHTS.

These resources are intended for skilled developers designing with TI products. You are solely responsible for (1) selecting the appropriate TI products for your application, (2) designing, validating and testing your application, and (3) ensuring your application meets applicable standards, and any other safety, security, regulatory or other requirements.

These resources are subject to change without notice. TI grants you permission to use these resources only for development of an application that uses the TI products described in the resource. Other reproduction and display of these resources is prohibited. No license is granted to any other TI intellectual property right or to any third party intellectual property right. TI disclaims responsibility for, and you will fully indemnify TI and its representatives against, any claims, damages, costs, losses, and liabilities arising out of your use of these resources.

TI's products are provided subject to [TI's Terms of Sale](#) or other applicable terms available either on [ti.com](#) or provided in conjunction with such TI products. TI's provision of these resources does not expand or otherwise alter TI's applicable warranties or warranty disclaimers for TI products.

TI objects to and rejects any additional or different terms you may have proposed.

Mailing Address: Texas Instruments, Post Office Box 655303, Dallas, Texas 75265

Copyright © 2025, Texas Instruments Incorporated