

FN7612-32-M4 ✓ ACTIVE

Schaffner | Schaffner FN761X

TE Internal #: 801832-SF

1000 VDC, 32 A, Threaded Stud, 18.85 mA Leakage Current @ 250VAC, 50Hz, IP00, UL 94V-0, Schaffner FN761X, Feedthrough EMC Filters

[View on TE.com >](#)



[EMI & EMC Solutions >](#) [EMC Filters >](#) [Power Line Filters >](#) [Feedthrough EMC Filters >](#)

[Feedthrough Filters FN761X: High-Performance AC Feedthrough Filters](#)

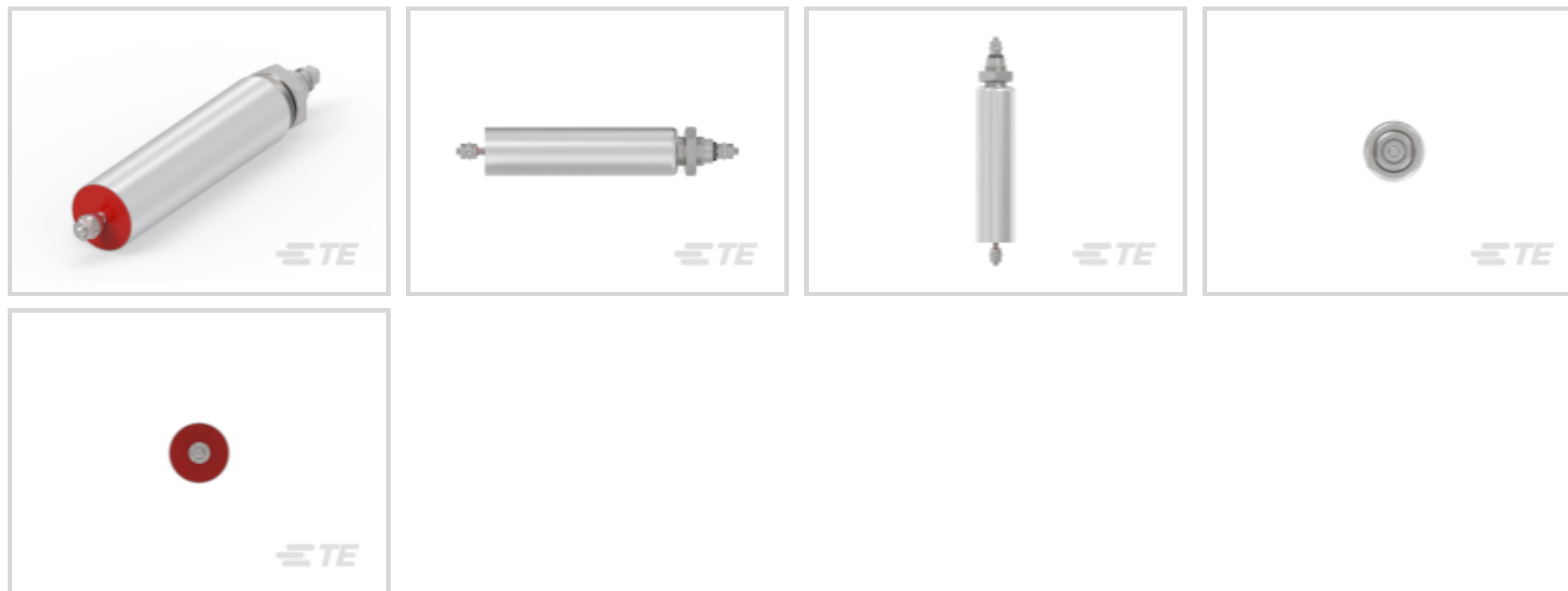

Operating Voltage (Max): **1000 VDC**

Current Rating (Max): **32 A**

Input Termination Type: **Threaded Stud**

Output Termination Type: **Threaded Stud**

IP Rating: **IP00**

[All Feedthrough Filters FN761X: High-Performance AC Feedthrough Filters \(7\)](#)

Features

Product Type Features

Input Termination Type	Threaded Stud
Output Termination Type	Threaded Stud

Electrical Characteristics

Operating Voltage (Max)	1000 VDC
Current Rating (Max)	32 A
Leakage Current (Max) (250VAC, 50Hz)	18.85 mA

Body Features

Product Weight	90 g[3.17 oz]
----------------	---------------

Dimensions

Product Width	25 mm[.98 in]
Product Length	148 mm[5.82 in]



Product Height	25 mm[.98 in]
----------------	---------------

Usage Conditions

Operating Temperature Range	-40 – 100 °C[-40 – 212 °F]
-----------------------------	----------------------------

Operation/Application

Cooling Method	Natural Convection
----------------	--------------------

Industry Standards

IP Rating	IP00
UL Flammability Rating	UL 94V-0

Other

Capacitor Class	Y2
-----------------	----

Product Compliance

[For compliance documentation, visit the product page on TE.com>](#)

EU RoHS Directive 2011/65/EU	Compliant
EU ELV Directive 2000/53/EC	Not Yet Reviewed
China RoHS 2 Directive MIIT Order No 32, 2016	有害物质含量符合标准要求 No Restricted Substance(s) Above Threshold
EU REACH Regulation (EC) No. 1907/2006	Current ECHA Candidate List: JUNE 2025 (250) Candidate List Declared Against: JUNE 2025 (250) Does not contain REACH SVHC
Halogen Content	Not Yet Reviewed for halogen content
Solder Process Capability	Not reviewed for solder process capability

Product Compliance Disclaimer

This information is provided based on reasonable inquiry of our suppliers and represents our current actual knowledge based on the information they provided. This information is subject to change. The part numbers that TE has identified as EU RoHS compliant have a maximum concentration of 0.1% by weight in homogenous materials for lead, hexavalent chromium, mercury, PBB, PBDE, DBP, BBP, DEHP, DIBP, and 0.01% for cadmium, or qualify for an exemption to these limits as defined in the Annexes of Directive 2011/65/EU (RoHS2). Finished electrical and electronic equipment products will be CE marked as required by Directive 2011/65/EU. Components may not be CE marked. Additionally, the part numbers that TE has identified as EU ELV compliant have a maximum concentration of 0.1% by weight in homogenous materials for lead, hexavalent chromium, and mercury, and 0.01% for cadmium, or qualify for an exemption to these limits as defined in the Annexes of Directive 2000/53/EC (ELV). Regarding the REACH Regulations, TE's information on SVHC in articles for this part number is still based on the European Chemical Agency (ECHA) 'Guidance on requirements for substances in articles'(Version: 2, April 2011), applying the 0.1% weight on weight concentration threshold at the finished product level. TE is aware of the European Court of Justice ruling of September 10th, 2015 also known as O5A (Once An Article Always An Article) stating that, in case of 'complex object', the threshold for a SVHC must be applied to both the product as a whole and simultaneously to each of the articles forming part of its composition. TE has evaluated this ruling based on the new ECHA "Guidance on requirements for substances in articles" (June 2017, version 4.0) and will be updating its statements accordingly.

Compatible Parts



TE Part # 801802-SF
FN7514-32-M4

Also in the Series | Schaffner FN761X



Feedthrough EMC Filters(7)

Customers Also Bought



TE Part #802427-SF
FN2030-3-06

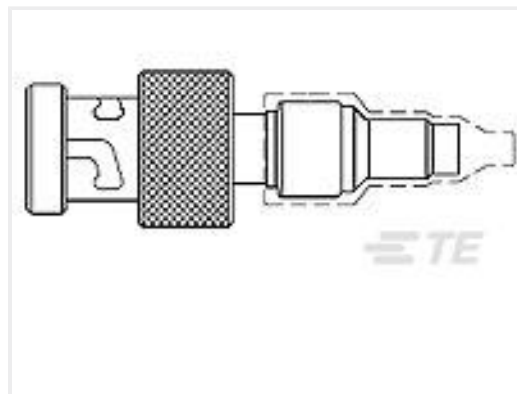

TE Part #734989-000
DK-621-0437-3S

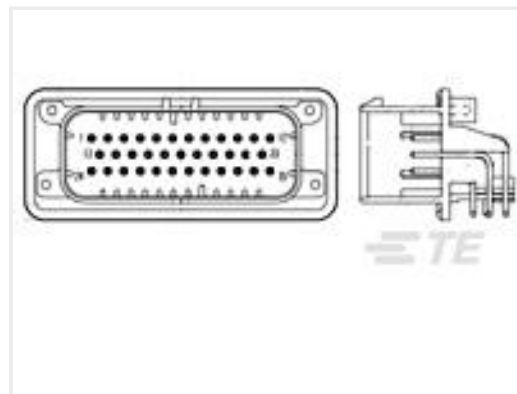

TE Part #1-776163-5
35POS,AMPSEAL,PIN HSG ASSY,SLD,
COD 5



TE Part #1393249-9
W58-XB1A4A-15=W58



TE Part #1-1393249-9
W58-XB1A4A-5=W58



TE Part #1-1625868-3
RP 2A 0.25W 39K2 0.1% 25PPM 1K RL

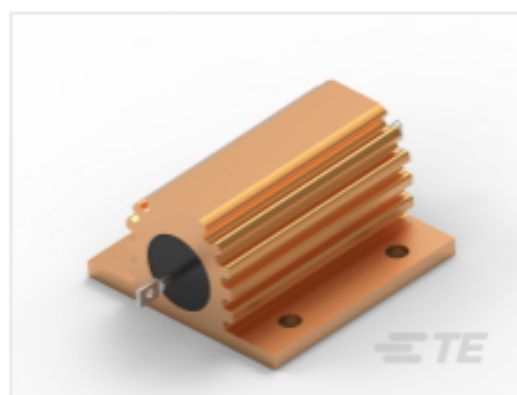

TE Part #CAT-C339-H85913
Power Resistors: Aluminum Housed,
HSA



TE Part #4-2176070-2
3521 510R 1% 2W

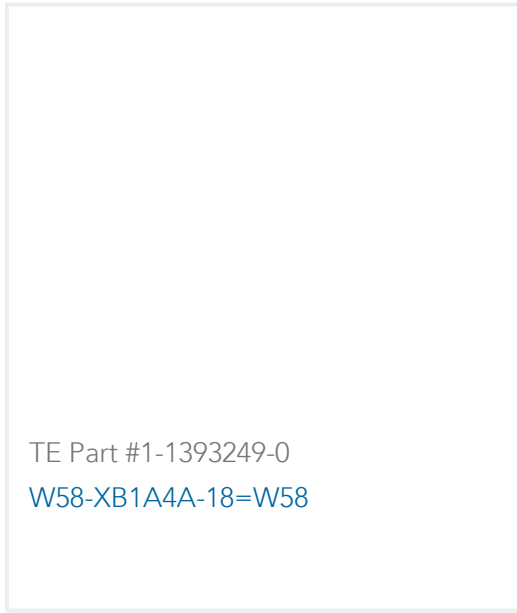

Documents

CAD Files

[3D PDF](#)

3D

Customer View Model

[ENG_CVM_CVM_801832-SF_B.3d_stp.zip](#)

English

Customer View Model

[ENG_CVM_CVM_801832-SF_B.2d_dxf.zip](#)

English

Customer View Model

[ENG_CVM_CVM_801832-SF_B.3d_igs.zip](#)

English

By downloading the CAD file I accept and agree to the [Terms and Conditions](#) of use.

Datasheets & Catalog Pages

[Feedthrough Filters FN761X](#)

English

Agency Approvals

[Intertek SE-ENEC-2401047](#)

English