

RoHS

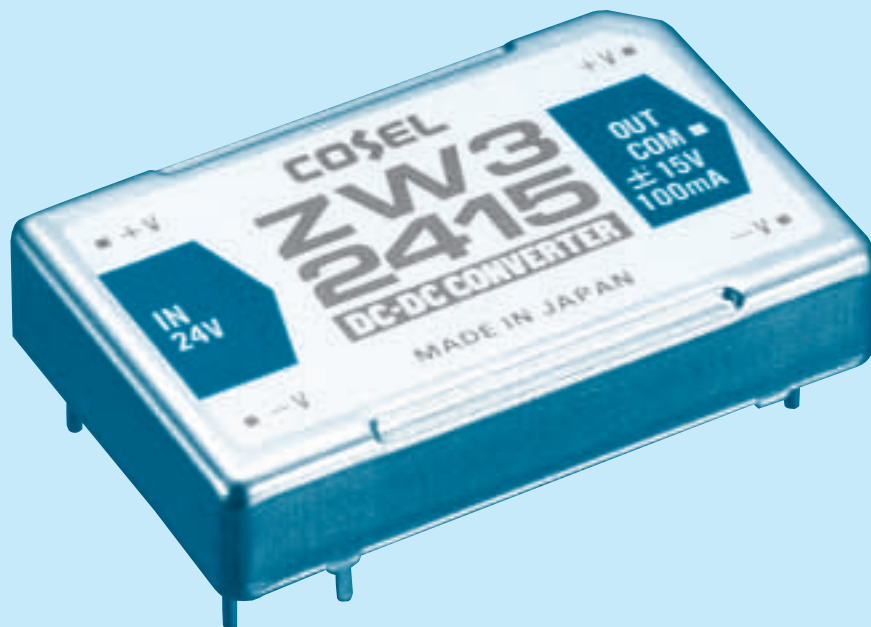

- ① Series name
- ② Dual output
- ③ Output wattage
- ④ Input voltage
- ⑤ Output voltage

MODEL	ZW30512	ZW30515	ZW31212	ZW31215	ZW32412	ZW32415	ZW34812	ZW34815
MAX OUTPUT WATTAGE[W]	2.88	3.0	2.88	3.0	2.88	3.0	2.88	3.0
DC OUTPUT	VOLTAGE[V]	±12 or +24	±15 or +30	±12 or +24	±15 or +30	±12 or +24	±15 or +30	±12 or +24
	CURRENT[A]	0.12	0.1	0.12	0.1	0.12	0.1	0.12

SPECIFICATIONS

Output pins can be connected in series to make a 24V/30V output.

	MODEL	ZW30512	ZW30515	ZW31212	ZW31215	ZW32412	ZW32415	ZW34812	ZW34815
INPUT	VOLTAGE[V]	5 (4.5 - 6.0)		12 (10 - 15)		24 (20 - 30)		48 (35 - 63)	
	CURRENT[A]	*1 0.880typ	0.920typ	0.342typ	0.358typ	0.163typ	0.171typ	0.085typ	0.090typ
	EFFICIENCY[%]	65typ	65typ	70typ	70typ	74typ	74typ	70typ	70typ
OUTPUT	VOLTAGE[V]	±12 (+24)	±15 (+30)	±12 (+24)	±15 (+30)	±12 (+24)	±15 (+30)	±12 (+24)	±15 (+30)
	CURRENT[A]	0.12	0.1	0.12	0.1	0.12	0.1	0.12	0.1
	LINE REGULATION[mV]	60max	75max	60max	75max	60max	75max	60max	75max
	LOAD REGULATION[mV]	600max	750max	600max	750max	600max	750max	600max	750max
	RIPPLE[mVp-p]	*2 120max	120max	120max	120max	120max	120max	120max	120max
	RIPPLE NOISE[mVp-p]	*2 120max	120max	120max	120max	120max	120max	120max	120max
	TEMPERATURE REGULATION[mV]	0 to +50°C	120max	150max	120max	150max	120max	150max	120max
	OUTPUT VOLTAGE ADJUSTMENT RANGE[V]	Fixed							
OUTPUT VOLTAGE SETTING[%]	±5max (Rated input/output, Ta=25°C)								
PROTECTION CIRCUIT	OVERCURRENT PROTECTION	Works over 105% of rating and recovers automatically							
ISOLATION	INPUT-OUTPUT	AC500V 1minute, Cutoff current = 10mA, DC500V 50MΩ min (20±15°C)							
	INPUT-CASE	AC500V 1minute, Cutoff current = 10mA, DC500V 50MΩ min (20±15°C)							
	OUTPUT-CASE	AC500V 1minute, Cutoff current = 10mA, DC500V 50MΩ min (20±15°C)							
ENVIRONMENT	OPERATING TEMP., HUMID. AND ALTITUDE	-10 to +60°C, 20 - 90%RH (Non condensing) (Refer to DERATING CURVE), 3,000m (10,000feet) max							
	STORAGE TEMP., HUMID. AND ALTITUDE	-20 to +75°C, 20 - 90%RH (Non condensing), 9,000m (30,000feet) max							
	VIBRATION	10 - 55Hz, 19.6m/s ² (2G), 3minutes period, 30minutes each along X, Y and Z axis							
	IMPACT	490.3m/s ² (50G), 11ms, once each X, Y and Z axis							

*1 Rated input 5V, 12V, 24V or 48V DC, I_o=100%
 *2 Measured by 20MHz oscilloscope.
 * Parallel operation with other model is not possible.
 * The output specification is at ±12V and ±5V.

External view

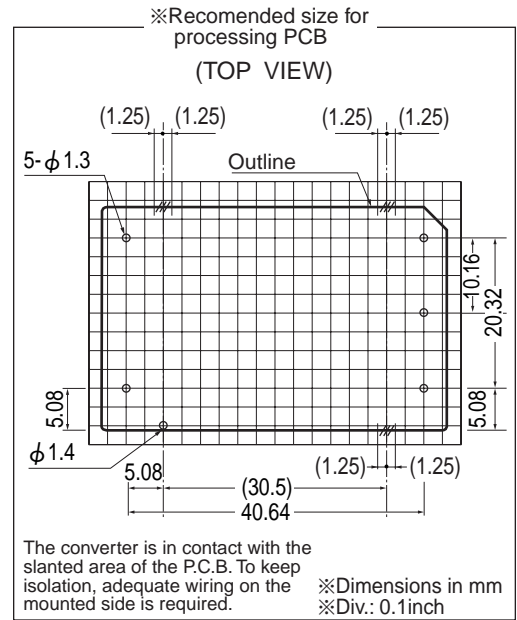
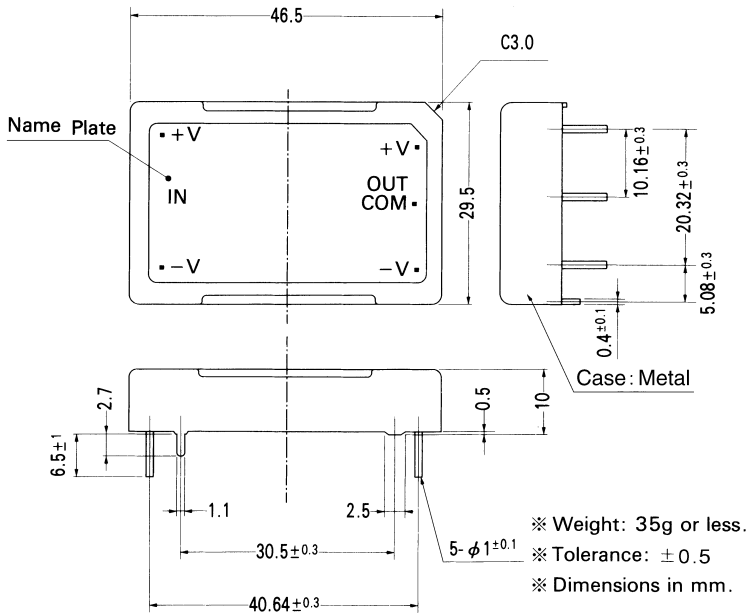

Performance data

■ STATIC CHARACTERISTICS (ZW30512)

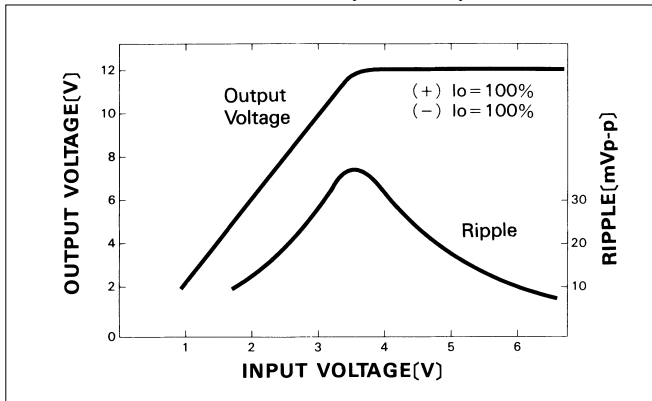

■ RISE TIME & FALL TIME (ZW30512)

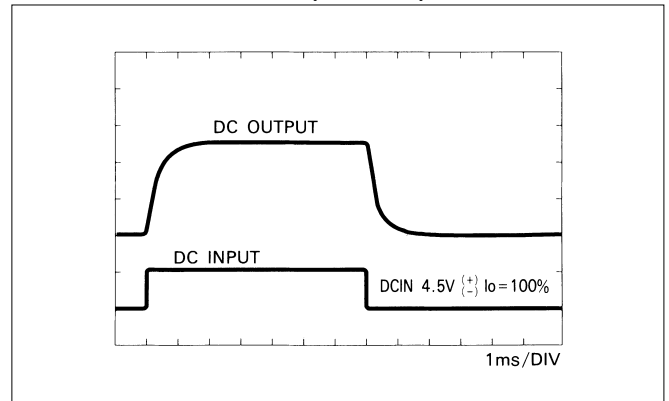

■ OVERCURRENT CHARACTERISTICS (ZW30512)

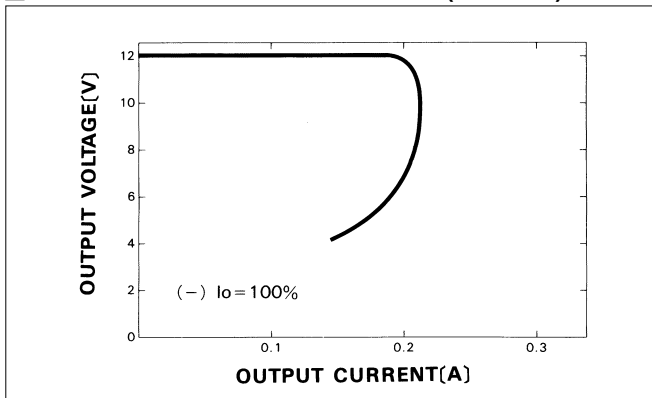

■ DERATING CURVE

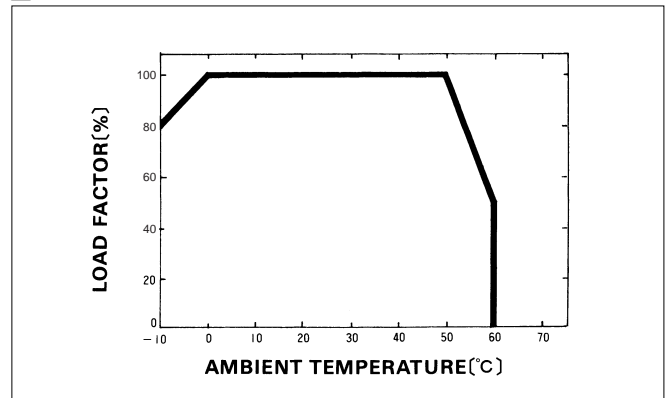

Z