

DELIVERY SPECIFICATION

SPEC. No. A-YFF-c

D A T E : Feb, 2020

To

Non-Controlled Copy

CUSTOMER'S PRODUCT NAME	TDK PRODUCT NAME 3-terminal Feed Through Filter Tape packaging 【RoHS compliant】 YFF18, YFF21, YFF31 Type
-------------------------	---

Please return this specification to TDK representatives with your signature.
 If orders are placed without returned specification, please allow us to judge that specification is accepted by your side.

RECEIPT CONFIRMATION

DATE: _____ YEAR _____ MONTH _____ DAY _____

Test conditions in this specification based on AEC-Q200 for automotive application.

TDK Corporation
 Sales
 Electronic Components
 Sales & Marketing Group

Engineering
 Electronic Components Business Company

APPROVED	Person in charge

APPROVED	CHECKED	Person in charge

SCOPE

This delivery specification shall be applied to 3-terminal feed through filter to be delivered to _____.

PRODUCTION PLACES

Production places defined in this specification shall be TDK Corporation, TDK(Suzhou)Co.,Ltd and TDK Components U.S.A.,Inc.

PRODUCT NAME

The name of the product to be defined in this specifications shall be YFF◇◇○○○△△□□□M.

COONTENTS

1. CODE CONSTRUCTION
2. RATED CURRENT
3. OPERATING TEMPERATURE RANGE
4. STORING CONDITION AND TERM
5. INDUSTRIAL WASTE DISPOSAL
6. PERFORMANCE
7. INSIDE STRUCTURE AND MATERIAL
8. PACKAGING
9. SOLDERING CONDITION
10. EQUIVALENT CIRCUIT DIAGRAM
11. CAUTION
12. TAPE PACKAGING SPECIFICATION

<EXPLANATORY NOTE>

When the mistrust in the spec arises, this specification is given priority. And it will be confirmed by written spec change after conference of both posts involved.

This specification warrants the quality of the 3-terminal feed through filter. Products should be evaluated or confirmed a state of mounted on your product.

If the use of the products goes beyond the bounds of this specification, we can not afford to guarantee.

Date	SPEC. No.
Feb, 2020	A-YFF-c

1. CODE CONSTRUCTION

(Example)	YFF18	AC	1C	104	M	T	○○○○
	YFF21	AC	1E	104	M	T	<u>○○○○</u>
	<u>YFF31</u>	<u>AH</u>	<u>2A</u>	<u>105</u>	<u>M</u>	<u>T</u>	<u>○○○○</u>
	(1)	(2)	(3)	(4)	(5)	(6)	(7)

(1)Type

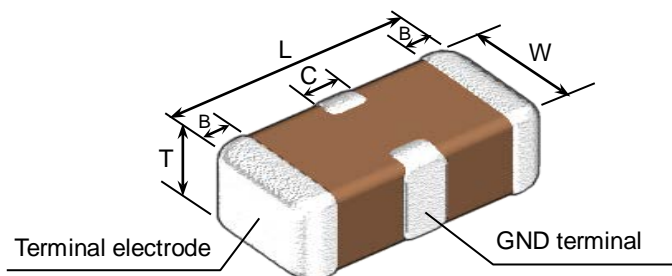

Type	Dimensions (mm)				
	L	W	T	B	C
YFF18	1.60±0.20	0.80±0.15	0.60±0.10	0.25±0.20	0.40±0.20
YFF21	2.00±0.20	1.25±0.20	0.85±0.15	0.30±0.20	0.50+0.30/-0.20
YFF31	3.20±0.20	1.60±0.20	1.30±0.20	0.40±0.30	1.20±0.30

*As for each item, please refer to detail page on TDK web.

(2)Product Classification

Symbol	Product Classification
A C	For Automotive general use
A H	For Automotive Large-current power Line

(3)Rated Voltage

Symbol	Rated Voltage
2 A	DC 100 V
1 H	DC 50 V
1 E	DC 25 V
1 C	DC 16 V
0 J	DC 6.3 V

(4) Rated Capacitance

Stated in three digits and in units of pico farads (pF). The first and Second digits identify the first and second significant figures of the capacitance, the third digit identifies the multiplier.

(Example)

Symbol	Rated Capacitance
104	100,000pF
105	1,000,000pF

(5)Capacitance tolerance

Symbol	Tolerance
M	± 20 %

(6)Packaging

Symbol	Packaging
T	Taping

(7)TDK internal code

2. RATED CURRENT

Rated current depend on operating temperature.
As for details, please refer to detail page on TDK web.

3. OPERATING TEMPERATURE RANGE

Min. operating Temperature	Max. operating Temperature	Reference Temperature
-55°C	125°C	25°C

4. STORING CONDITION AND TERM

Storing temperature	Storing humidity	Storing term
5~40°C	20~70%RH	Within 6 months upon receipt.

5. INDUSTRIAL WASTE DISPOSAL

Dispose this product as industrial waste in accordance with the industrial Waste Law.

6. PERFORMANCE

Table 1

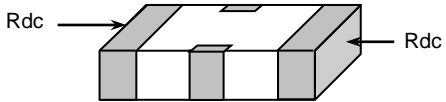
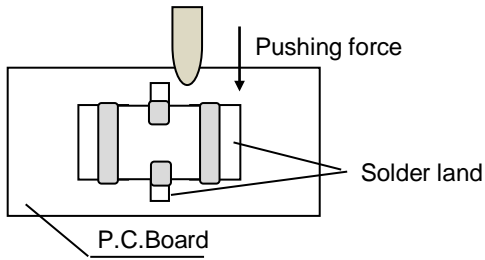
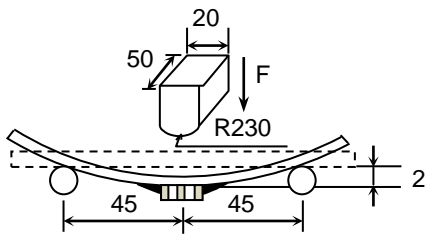
No.	Item	Performance	Test or inspection method
1	External Appearance	No defects which may affect performance.	Inspect with magnifying glass (3×).
2	Insulation Resistance	10,000MΩ or 500MΩ·μF min. (As for the products of rated voltage 16V DC and lower, 100MΩ·μF min.), whichever smaller.	Measuring voltage : Rated voltage Voltage application time : 60s.
3	Direct Current Resistance (Rdc)	Please refer to detail page on TDK web.	Measuring current shall be 100mA max. 
4	Voltage Proof	Withstand test voltage without insulation breakdown or other damage.	Apply voltage : 2.5 × rated voltage Voltage application time : 1s. Charge / discharge current : 50mA or lower
5	Capacitance	Within the specified tolerance.	As for measuring condition, please contact with our sales representative.
6	Robustness of Terminations	No sign of termination coming off, breakage of ceramic, or other abnormal signs.	Reflow solder the products on a P.C.Board shown in Appendix 2. Apply a pushing force gradually to a specimen as shown in the following figure. pushing force : 17.7N. 
7	Bending	External appearance	Reflow solder the products on a P.C.Board shown in Appendix 1 and bend it for 2mm. (1mm is applied for YFF31AH type.)  (Unit : mm)
	Capacitance	Change from the value before test ± 12.5 %	
	Direct current Resistance (Rdc)	Please contact with our sales representative.	

(continued)

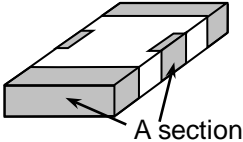
No.	Item	Performance	Test or inspection method	
8	Solderability	<p>New solder to cover over 75% of termination. 25% may have pin holes or rough spots but not concentrated in one spot. Ceramic surface of A sections shall not be exposed due to melting or shifting of termination material.</p> 	<p>Solder : Sn-3.0Ag-0.5Cu or Sn-37Pb</p> <p>Flux : Isopropyl alcohol (JIS K 8839) Rosin (JIS K 5902) 25% solid solution.</p> <p>Solder temp. : 245±5°C (Sn-3.0Ag-0.5Cu) 235±5°C (Sn-37Pb)</p> <p>Dwell time : 3±0.3s.(Sn-3.0Ag-0.5Cu) 2±0.2s.(Sn-37Pb)</p> <p>Solder position : Until both terminations are completely soaked.</p>	
9	Resistance to solder heat	<p>External appearance</p> <p>Capacitance</p> <p>Direct current resistance (Rdc)</p>	<p>No cracks are allowed and terminations shall be covered at least 60% with new solder.</p> <p>Change from the value before test</p> <p>± 7.5 %</p> <p>Please contact with our sales representative.</p>	<p>Solder : Sn-3.0Ag-0.5Cu or Sn-37Pb</p> <p>Flux : Isopropyl alcohol (JIS K 8839) Rosin (JIS K 5902) 25% solid solution.</p> <p>Solder temp. : 260±5°C</p> <p>Dwell time : 10±1s.</p> <p>Solder position : Until both terminations are completely soaked.</p> <p>Pre-heating : Temp. — 110~140°C Time — 30~60s.</p> <p>Leave the products in ambient condition for 24±2h before measurement.</p>
10	Vibration	<p>External appearance</p> <p>Capacitance</p> <p>Direct current resistance (Rdc)</p>	<p>No mechanical damage.</p> <p>Change from the value before test</p> <p>± 7.5 %</p> <p>Please contact with our sales representative.</p>	<p>Applied force : 5G max.</p> <p>Frequency : 10~2,000Hz</p> <p>Reciprocating sweep time : 20 min.</p> <p>Cycle : 12 cycles in each 3 mutually perpendicular directions.</p> <p>Reflow solder the products on a P.C.Board shown in Appendix 2 before testing.</p>

(continued)

No.	Item	Performance	Test or inspection method															
11	Temperature cycle	External appearance	Expose the products in the condition step1 through step 4 listed in the following table. Temp. cycle : 1,000 cycles <table border="1"> <thead> <tr> <th>Step</th> <th>Temperature(°C)</th> <th>Time (min.)</th> </tr> </thead> <tbody> <tr> <td>1</td> <td>Min. operating temp. ± 3</td> <td>30 ± 3</td> </tr> <tr> <td>2</td> <td>Ambient Temp.</td> <td>2 ~ 5</td> </tr> <tr> <td>3</td> <td>Max. operating temp. ± 2</td> <td>30 ± 2</td> </tr> <tr> <td>4</td> <td>Ambient Temp.</td> <td>2 ~ 5</td> </tr> </tbody> </table> As for Min./ Max. operating temp., please refer to "3.OPERATING TEMPERATURE RANGE". Leave the products in ambient condition for 24 \pm 2h before measurement. Reflow solder the products on a P.C.Board shown in Appendix 2 before testing.	Step	Temperature(°C)	Time (min.)	1	Min. operating temp. ± 3	30 ± 3	2	Ambient Temp.	2 ~ 5	3	Max. operating temp. ± 2	30 ± 2	4	Ambient Temp.	2 ~ 5
	Step	Temperature(°C)		Time (min.)														
	1	Min. operating temp. ± 3		30 ± 3														
	2	Ambient Temp.		2 ~ 5														
3	Max. operating temp. ± 2	30 ± 2																
4	Ambient Temp.	2 ~ 5																
Capacitance	No mechanical damage. <hr/> Change from the value before test <hr/> Please contact with our sales representative.																	
Direct current resistance (Rdc)	Please contact with our sales representative.																	
Insulation Resistance	Meet the initial spec.																	
12	Moisture Resistance (Steady State)	External appearance	Test temp. : 40 \pm 2°C Test humidity : 90~95%RH Test time : 500 +24,0h Leave the products in ambient condition for 24 \pm 2h before measurement. Reflow solder the products on a P.C.Board shown in Appendix 2 before testing.															
		Capacitance		No mechanical damage. <hr/> Change from the value before test <hr/> Please contact with our sales representative.														
		Direct current resistance (Rdc)		Please contact with our sales representative.														
		Insulation Resistance		1,000M Ω or 50M Ω · μ F min. (As for the products of rated voltage 16V DC and lower, 10M Ω · μ F min.), whichever smaller.														

(continued)

No.	Item	Performance	Test or inspection method
13	Moisture Resistance	External appearance	No mechanical damage.
		Capacitance	Change from the value before test Please contact with our sales representative.
		Direct current resistance (Rdc)	Please contact with our sales representative.
		Insulation Resistance	500MΩ or 25MΩ·μF min. (As for the products of rated voltage 16V DC and lower, 5MΩ·μF min.), whichever smaller.
14	Life	External appearance	No mechanical damage.
		Capacitance	Change from the value before test Please contact with our sales representative.
		Direct current resistance (Rdc)	Please contact with our sales representative.
		Insulation Resistance	1,000MΩ or 50MΩ·μF min. (As for the products of rated voltage 16V DC and lower, 10MΩ·μF min.), whichever smaller.
			<p>Test temp. : 85±2°C Test humidity : 85%RH Applied voltage : Rated voltage Test time : 1,000 +48,0h</p> <p>Charge/discharge current : 50mA or lower</p> <p>Leave the products in ambient condition for 24±2h before measurement.</p> <p>Reflow solder the products on a P.C.Board shown in Appendix2 before testing.</p> <p>Initial value setting Voltage conditioning «After voltage treat the products under testing temperature and voltage for 1 hour,» leave the products in ambient condition for 24±2h before measurement. Use this measurement for initial value.</p>
			<p>Test temp. : Maximum operating temperature±2°C Applied voltage : Please contact with our sales representative. Test time : 1,000 +48,0h</p> <p>Charge/discharge current : 50mA or lower</p> <p>Leave the products in ambient condition for 24±2h before measurement.</p> <p>Reflow solder the products on a P.C.Board shown in Appendix2 before testing.</p> <p>Initial value setting Voltage conditioning «After voltage treat the products under testing temperature and voltage for 1 hour,» leave the products in ambient condition for 24±2h before measurement. Use this measurement for initial value.</p>

*As for the initial measurement of product on number 7, 9, 10, 11 and 12, leave products at 150 0,-10°C for 1h and measure the value after leaving product for 24±2h in ambient condition.

Appendix 1

P.C.Board for bending test

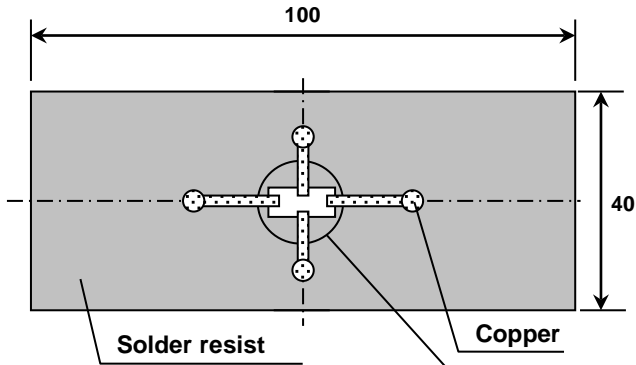

Appendix 2

P.C.Board for reliability test

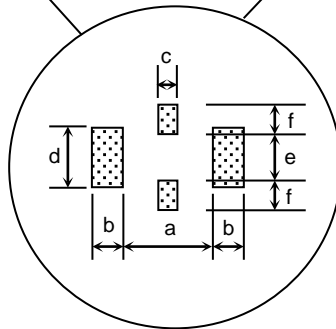
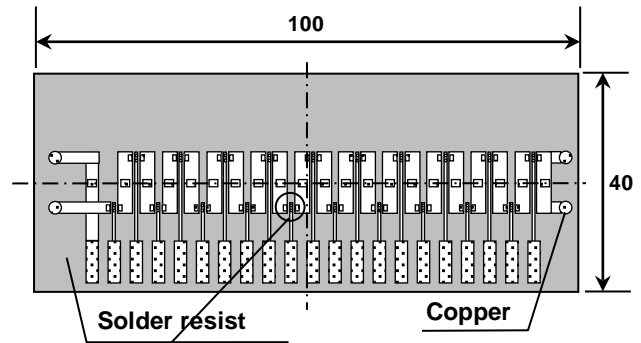



(Unit: mm)

Type	Dimensions					
	a	b	c	d	e	F
YFF18	1.0	0.6	0.4	0.6	0.4	0.4
YFF21	1.4	0.6	0.5	0.8	0.6	0.65
YFF31	2.5	1.2	1.4	1.3	0.8	0.9

1. Material : Glass Epoxy(As per JIS C6484 GE4)

2. Thickness : Appendix 1 — 1.0mm
 : Appendix 2 — 1.6mm

 Copper(Thickness:0.035mm)
 Solder resist

7. INSIDE STRUCTURE AND MATERIAL

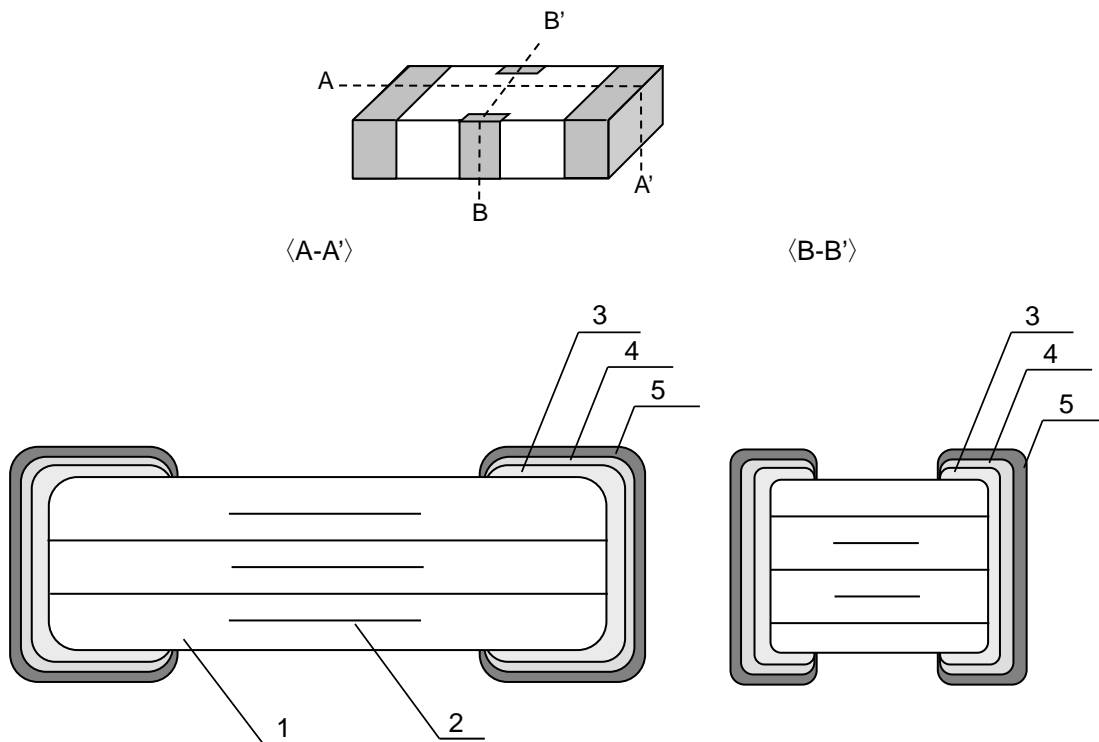

No.	NAME	MATERIAL
1	Dielectric	CaZrO ₃ or BaTiO ₃
2	Electrode	Ni
3	Termination	Cu
4		Ni
5		Sn

8. PACKAGING

Packaging shall be done to protect the components from the damage during transportation and storing, and a label which has the following information shall be attached.

Tape packaging is as per 12. TAPE PACKAGING SPECIFICATION.

- 1) Inspection No.
- 2) TDK P/N
- 3) Customer's P/N
- 4) Quantity

*Composition of Inspection No.

Example F 9 A - 23 - 001
 (a) (b) (c) (d) (e)

- (a) Line code
- (b) Last digit of the year
- (c) Month and A for January and B for February and so on. (Skip I)
- (d) Inspection Date of the month.
- (e) Serial No. of the day

*Composition of new Inspection No.

(Will be implemented on and after May 1, 2019)

Example

I	F	9	E	2	3	A	0	0	1
(a)	(b)	(c)	(d)	(e)	(f)	(g)			

- (a) Prefix
- (b) Line code
- (c) Last digit of the year
- (d) Month and A for January and B for February and so on. (Skip I)
- (e) Inspection Date of the month.
- (f) Serial No. of the day(00 ~ ZZ)
- (g) Suffix(00 ~ ZZ)

* It is planned to shift to the new inspection No. on and after May 2019, but the implementation timing may be different depending on shipment bases.
 Until the shift is completed, either current or new composition of inspection No. will be applied.

9. SOLDERING CONDITION

Reflow soldering only.

10. EQUIVALENT CIRCUIT DIAGRAM

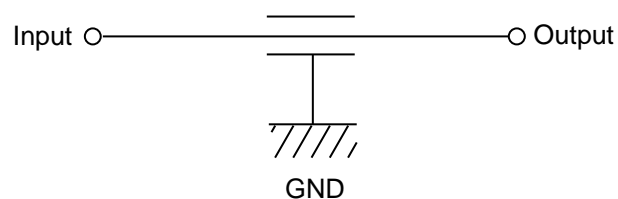
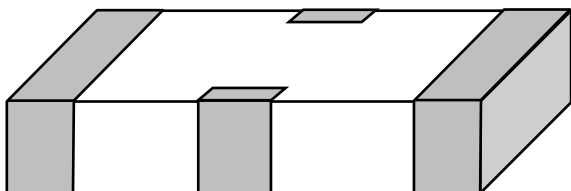

11. CAUTION

No.	Process	Condition
1	Operating Condition (Storage, Use, Transportation)	<p>1-1. Storage, Use</p> <ol style="list-style-type: none"> 1) The product must be stored in an ambient temperature of 5 to 40°C with a relative humidity of 20 to 70%RH. The products should be used within 6 months upon receipt. 2) The product must be operated and stored in an environment free of dew condensation and these gases such as Hydrogen Sulphide, Hydrogen Sulphate, Chlorine, Ammonia and sulfur. 3) Avoid storing in sun light and falling of dew. 4) Do not use product under high humidity and high and low atmospheric pressure which may affect product reliability. 5) Product should be tested for the solderability when they are stored for long time. <p>1-2. Handling in transportation</p> <p>In case of the transportation of the product, the performance of the product may be deteriorated depending on the transportation condition. (Refer to JEITA RCR-2335C 9.2 Handling in transportation)</p>
2	Circuit design  Caution	<p>2-1. Operating temperature</p> <p>Operating temperature should be followed strictly within this specification, especially be careful with maximum temperature.</p> <ol style="list-style-type: none"> 1) Do not use product above the maximum allowable operating temperature. 2) Surface temperature including self heating should be below maximum operating temperature. (Due to dielectric loss, product will heat itself when AC is applied. Especially at high frequencies around its SRF, the heat might be so extreme that it may damage itself or the product mounted on. Please design the circuit so that the maximum temperature of the product including the self heating to be below the maximum allowable operating temperature. Temperature rise at product's surface shall be below 20°C) 3) The electrical characteristics of the product will vary depending on the temperature. The product should be selected and designed in taking the temperature into consideration.

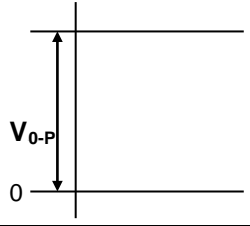
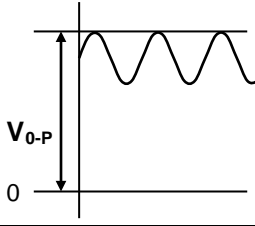
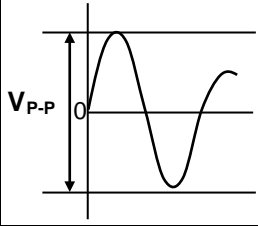
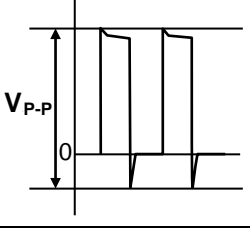
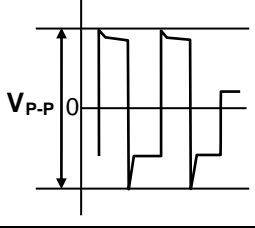
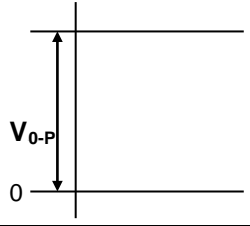
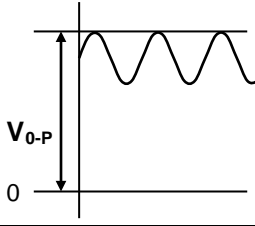
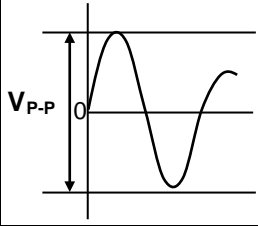
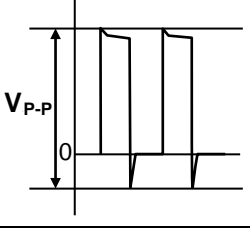
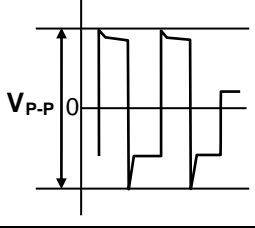
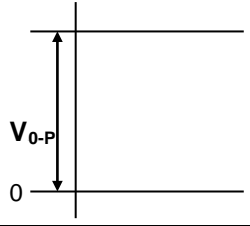
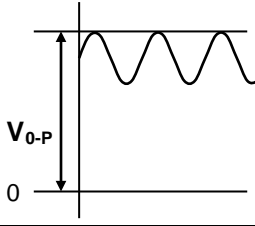
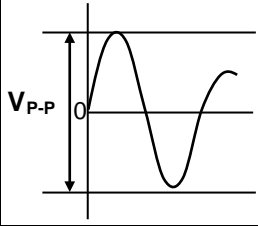
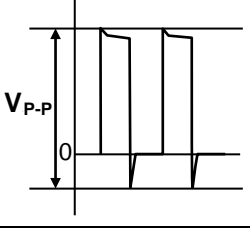
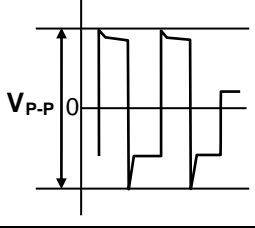
No.	Process	Condition														
2	Circuit design  Caution	<p>2-2. Operating voltage</p> <p>1) Operating voltage across the terminals should be below the rated voltage. When AC and DC are super imposed, V_{0-P} must be below the rated voltage. — (1) and (2)</p> <p>AC or pulse with overshooting, V_{P-P} must be below the rated voltage. — (3), (4) and (5)</p> <p>When the voltage is started to apply to the circuit or it is stopped applying, the irregular voltage may be generated for a transit period because of resonance or switching. Be sure to use the product within rated voltage containing these Irregular voltage.</p> <table border="1" data-bbox="424 544 1398 815"> <thead> <tr> <th data-bbox="424 544 619 584">Voltage</th> <th data-bbox="624 544 874 584">(1) DC voltage</th> <th data-bbox="879 544 1134 584">(2) DC+AC voltage</th> <th data-bbox="1139 544 1398 584">(3) AC voltage</th> </tr> </thead> <tbody> <tr> <td data-bbox="424 591 619 815">Positional Measurement (Rated voltage)</td> <td data-bbox="624 591 874 815">  </td> <td data-bbox="879 591 1134 815">  </td> <td data-bbox="1139 591 1398 815">  </td> </tr> </tbody> </table> <table border="1" data-bbox="424 846 1134 1120"> <thead> <tr> <th data-bbox="424 846 619 887">Voltage</th> <th data-bbox="624 846 874 887">(4) Pulse voltage (A)</th> <th data-bbox="879 846 1134 887">(5) Pulse voltage (B)</th> </tr> </thead> <tbody> <tr> <td data-bbox="424 893 619 1120">Positional Measurement (Rated voltage)</td> <td data-bbox="624 893 874 1120">  </td> <td data-bbox="879 893 1134 1120">  </td> </tr> </tbody> </table> <p>2) Even below the rated voltage, if repetitive high frequency AC or pulse is applied, the reliability of the products may be reduced.</p> <p>3) The effective capacitance will vary depending on applied DC and AC voltages. The products should be selected and designed in taking the voltages into consideration.</p> <p>2-3. Frequency</p> <p>When the products are used in AC and/or pulse voltages, the products may vibrate themselves and generate audible sound.</p>	Voltage	(1) DC voltage	(2) DC+AC voltage	(3) AC voltage	Positional Measurement (Rated voltage)				Voltage	(4) Pulse voltage (A)	(5) Pulse voltage (B)	Positional Measurement (Rated voltage)		
Voltage	(1) DC voltage	(2) DC+AC voltage	(3) AC voltage													
Positional Measurement (Rated voltage)																
Voltage	(4) Pulse voltage (A)	(5) Pulse voltage (B)														
Positional Measurement (Rated voltage)																
3	Designing P.C.board	<p>The amount of solder at the terminations has a direct effect on the reliability of the products.</p> <p>1) The greater the amount of solder, the higher the stress on the products, and the more likely that it will break. When designing a P.C.board, determine the shape and size of the solder lands to have proper amount of solder on the terminations.</p> <p>2) Avoid using common solder land for multiple terminations and provide individual solder land for each terminations.</p>														

No.	Process	Condition																												
3	Designing P.C.board	<p>3) Size and recommended land dimensions.</p> <p>Chip mounted size</p> <p> Resist Land pattern Land pattern & Resist </p> <p>YFF Series is having the unique Ground structure and eliminate unnecessary noise at the wide frequency range. The following points should be considered at the pad design to obtain the better performance.</p> <ol style="list-style-type: none"> 1) Ground pattern should be designed as big as possible. 2) Make through hole and connect to the ground pattern of the chip mounted side. 3) Through hole should be designed as close to GND terminal as possible. <p>Notes) *If through hole is too big, solder paste way came into the hole and make bad connection with the ground pattern.</p> <p style="text-align: right;">(mm)</p> <table border="1" style="width: 100%; border-collapse: collapse;"> <thead> <tr> <th style="text-align: center;">Symbol</th> <th style="text-align: center;">a</th> <th style="text-align: center;">b</th> <th style="text-align: center;">c</th> <th style="text-align: center;">d</th> <th style="text-align: center;">e</th> <th style="text-align: center;">f</th> </tr> </thead> <tbody> <tr> <td style="text-align: center;">YFF18</td> <td style="text-align: center;">1.00</td> <td style="text-align: center;">0.60</td> <td style="text-align: center;">0.40</td> <td style="text-align: center;">0.60</td> <td style="text-align: center;">0.40</td> <td style="text-align: center;">0.40</td> </tr> <tr> <td style="text-align: center;">YFF21</td> <td style="text-align: center;">1.40</td> <td style="text-align: center;">0.60</td> <td style="text-align: center;">0.50</td> <td style="text-align: center;">0.80</td> <td style="text-align: center;">0.60</td> <td style="text-align: center;">0.65</td> </tr> <tr> <td style="text-align: center;">YFF31</td> <td style="text-align: center;">2.50</td> <td style="text-align: center;">1.20</td> <td style="text-align: center;">1.40</td> <td style="text-align: center;">1.30</td> <td style="text-align: center;">0.80</td> <td style="text-align: center;">0.90</td> </tr> </tbody> </table>	Symbol	a	b	c	d	e	f	YFF18	1.00	0.60	0.40	0.60	0.40	0.40	YFF21	1.40	0.60	0.50	0.80	0.60	0.65	YFF31	2.50	1.20	1.40	1.30	0.80	0.90
Symbol	a	b	c	d	e	f																								
YFF18	1.00	0.60	0.40	0.60	0.40	0.40																								
YFF21	1.40	0.60	0.50	0.80	0.60	0.65																								
YFF31	2.50	1.20	1.40	1.30	0.80	0.90																								

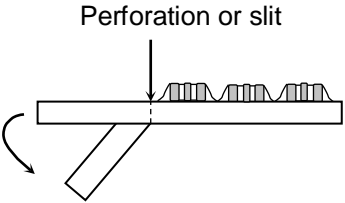
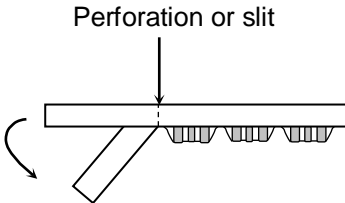
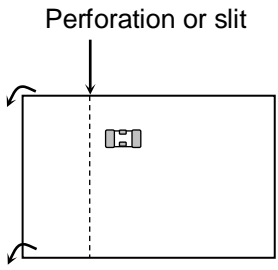
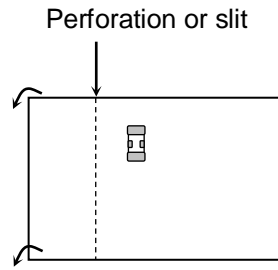
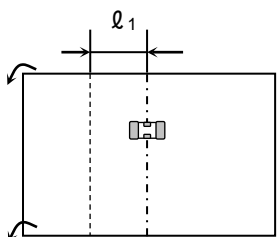
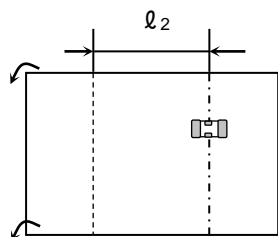
No.	Process	Condition		
3	Designing P.C.board	4) Recommended product layout is as following.		
			Disadvantage against bending stress	Advantage against bending stress
		Mounting face	<p>Perforation or slit</p>  <p>Break P.C.board with mounted side up.</p>	<p>Perforation or slit</p>  <p>Break P.C.board with mounted side down.</p>
		Chip arrangement (Direction)	<p>Mount perpendicularly to perforation or slit</p> <p>Perforation or slit</p> 	<p>Mount in parallel with perforation or slit</p> <p>Perforation or slit</p> 
		Distance from slit	<p>Closer to slit is higher stress</p>  <p>($l_1 < l_2$)</p>	<p>Away from slit is less stress</p>  <p>($l_1 < l_2$)</p>

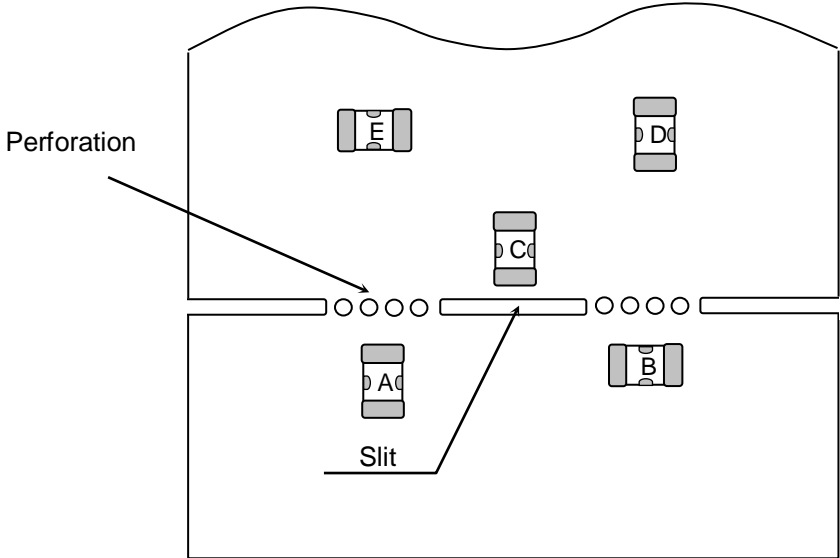
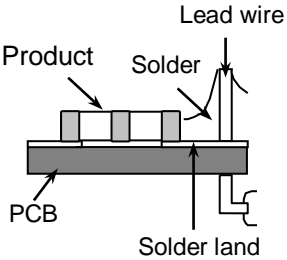
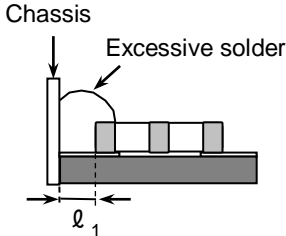
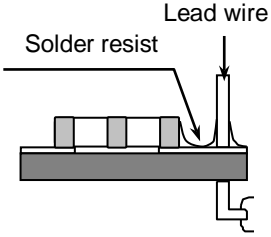
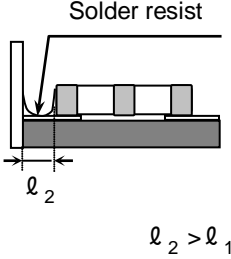
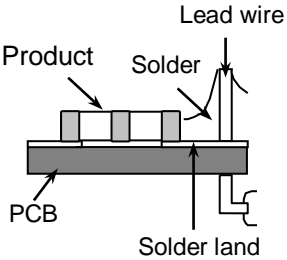
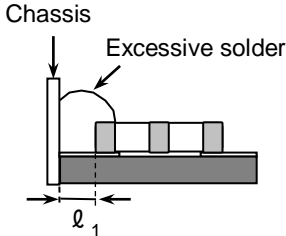
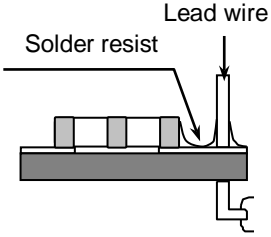
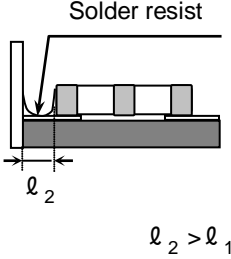
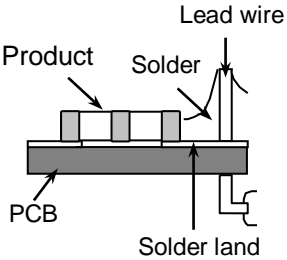
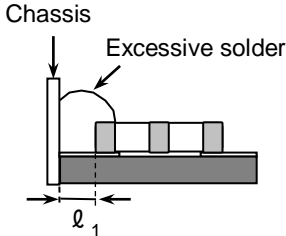
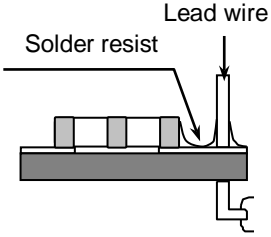
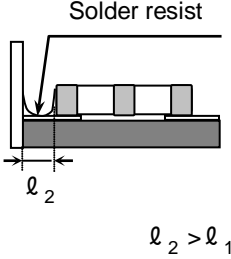
No.	Process	Condition									
3	Designing P.C.board	<p>5) Mechanical stress varies according to location of product on the P.C.board.</p>  <p>The stress in product is in the following order. $A > B = C > D > E$</p> <p>6) Layout recommendation</p> <table border="1" data-bbox="376 1010 1473 1921"> <thead> <tr> <th data-bbox="376 1010 593 1126">Example</th> <th data-bbox="593 1010 1035 1126">Use of common solder land</th> <th data-bbox="1035 1010 1473 1126">Soldering with chassis</th> </tr> </thead> <tbody> <tr> <td data-bbox="376 1126 593 1507">Need to avoid</td> <td data-bbox="593 1126 1035 1507">  </td> <td data-bbox="1035 1126 1473 1507">  </td> </tr> <tr> <td data-bbox="376 1507 593 1921">Recommendation</td> <td data-bbox="593 1507 1035 1921">  </td> <td data-bbox="1035 1507 1473 1921">  <p>$l_2 > l_1$</p> </td> </tr> </tbody> </table>	Example	Use of common solder land	Soldering with chassis	Need to avoid			Recommendation		 <p>$l_2 > l_1$</p>
Example	Use of common solder land	Soldering with chassis									
Need to avoid											
Recommendation		 <p>$l_2 > l_1$</p>									

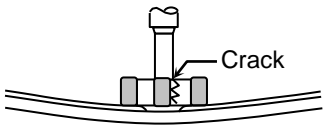
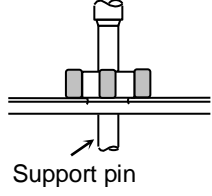
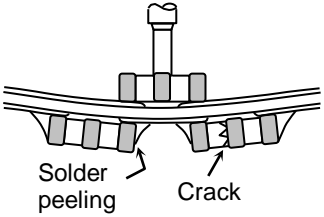
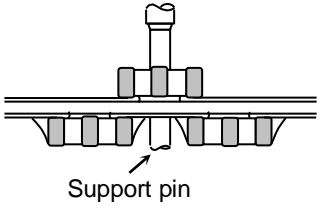
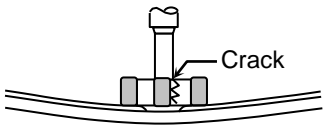
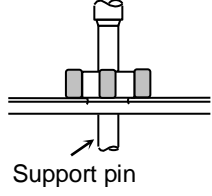
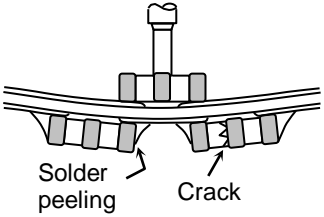
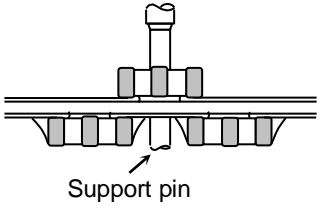
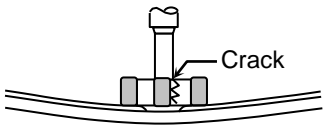
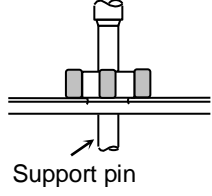
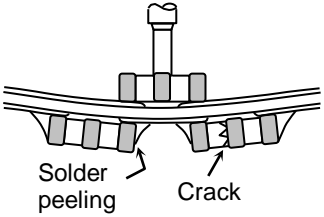
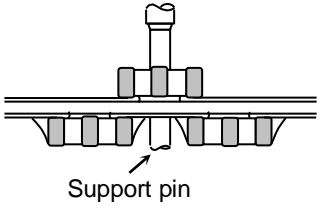
No.	Process	Condition									
4	Mounting	<p>4-1. Stress from mounting head</p> <p>If the mounting head is adjusted too low, it may induce excessive stress in the product to result in cracking. Please take following precautions.</p> <ol style="list-style-type: none"> 1) Adjust the bottom dead center of the mounting head to reach on the P.C.board surface and not press it. 2) Adjust the mounting head pressure to be 1 to 3N of static weight. 3) To minimize the impact energy from mounting head, it is important to provide support from the bottom side of the P.C.board. <p>See following examples.</p> <table border="1" data-bbox="421 672 1388 1243"> <thead> <tr> <th data-bbox="421 672 619 725"></th> <th data-bbox="619 672 1013 725">Not recommended</th> <th data-bbox="1013 672 1388 725">Recommended</th> </tr> </thead> <tbody> <tr> <td data-bbox="421 725 619 981">Single sided mounting</td> <td data-bbox="619 725 1013 981">  </td> <td data-bbox="1013 725 1388 981">  </td> </tr> <tr> <td data-bbox="421 981 619 1243">Double-sides mounting</td> <td data-bbox="619 981 1013 1243">  </td> <td data-bbox="1013 981 1388 1243">  </td> </tr> </tbody> </table> <p>When the centering jaw is worn out, it may give mechanical impact on the product to cause crack. Please control the close up dimension of the centering jaw and provide sufficient preventive maintenance and replacement of it.</p>		Not recommended	Recommended	Single sided mounting			Double-sides mounting		
	Not recommended	Recommended									
Single sided mounting											
Double-sides mounting											

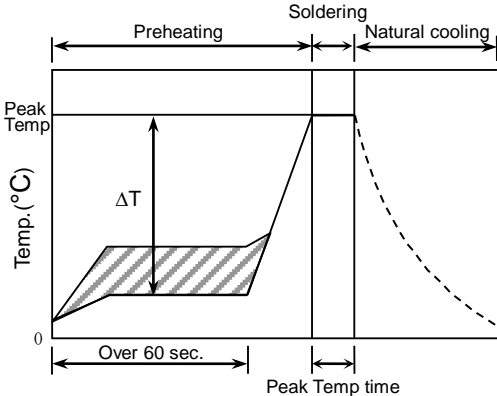
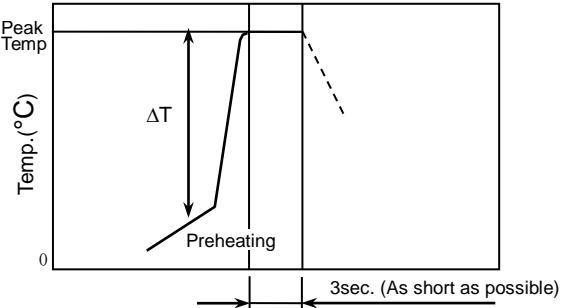
No.	Process	Condition														
5	Soldering	<p>5-1. Flux selection</p> <p>Flux can seriously affect the performance of products. Confirm the following to select the appropriate flux.</p> <ol style="list-style-type: none"> 1) It is recommended to use a mildly activated rosin flux (less than 0.1wt% chlorine). Strong flux is not recommended. 2) Excessive flux must be avoided. Please provide proper amount of flux. 3) When water-soluble flux is used, enough washing is necessary. <p>5-2. Recommended soldering profile by various methods</p> <div style="text-align: center;"> <p>Reflow soldering</p>  </div> <div style="text-align: center;"> <p>Manual soldering (Solder iron)</p>  </div> <p>* As for peak temperature of manual soldering, please refer “5-6. Solder repair by solder iron” .</p> <p>5-3. Recommended soldering peak temp and peak temp duration</p> <table border="1" data-bbox="502 1556 1177 1792"> <thead> <tr> <th rowspan="2" style="text-align: center;">Temp./Duration</th> <th colspan="2" style="text-align: center;">Reflow soldering</th> </tr> <tr> <th style="text-align: center;">Peak temp(°C)</th> <th style="text-align: center;">Duration(sec.)</th> </tr> </thead> <tbody> <tr> <td style="text-align: center;">Solder</td> <td></td> <td></td> </tr> <tr> <td style="text-align: center;">Sn-Pb Solder</td> <td style="text-align: center;">230 max.</td> <td style="text-align: center;">20 max.</td> </tr> <tr> <td style="text-align: center;">Lead Free Solder</td> <td style="text-align: center;">260 max.</td> <td style="text-align: center;">10 max.</td> </tr> </tbody> </table> <p>Recommended solder compositions Lead Free Solder : Sn-3.0Ag-0.5Cu Sn-Pb solder : Sn-37Pb</p>	Temp./Duration	Reflow soldering		Peak temp(°C)	Duration(sec.)	Solder			Sn-Pb Solder	230 max.	20 max.	Lead Free Solder	260 max.	10 max.
Temp./Duration	Reflow soldering															
	Peak temp(°C)	Duration(sec.)														
Solder																
Sn-Pb Solder	230 max.	20 max.														
Lead Free Solder	260 max.	10 max.														

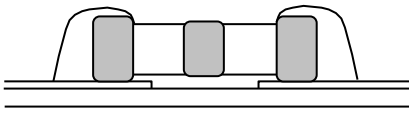
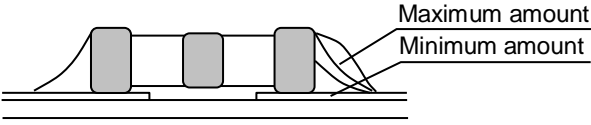
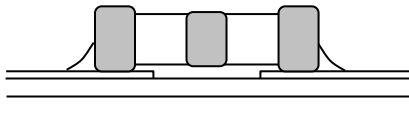
No.	Process	Condition														
5	Soldering	<p>5-4. Avoiding thermal shock</p> <p>1) Preheating condition</p> <table border="1" data-bbox="539 309 976 472"> <thead> <tr> <th>Soldering</th> <th>Temp. (°C)</th> </tr> </thead> <tbody> <tr> <td>Reflow soldering</td> <td>$\Delta T \leq 150$</td> </tr> <tr> <td>Manual soldering</td> <td>$\Delta T \leq 150$</td> </tr> </tbody> </table> <p>2) Cooling condition Natural cooling using air is recommended. If the product is dipped into a solvent for cleaning, the temperature difference (ΔT) must be less than 100°C.</p> <p>5-5. Amount of solder Excessive solder will induce higher tensile force in product when temperature changes and it may result in chip cracking. In sufficient solder may detach the product from the P.C.board.</p> <div style="display: flex; justify-content: space-between; align-items: flex-start;"> <div style="width: 30%;">Excessive solder</div> <div style="width: 30%; text-align: center;">  </div> <div style="width: 30%;">Higher tensile force in product to cause crack</div> </div> <hr/> <div style="display: flex; justify-content: space-between; align-items: center;"> <div style="width: 30%;">Adequate</div> <div style="width: 30%; text-align: center;">  </div> </div> <hr/> <div style="display: flex; justify-content: space-between; align-items: flex-start;"> <div style="width: 30%;">Insufficient solder</div> <div style="width: 30%; text-align: center;">  </div> <div style="width: 30%;">Low robustness may cause contact failure or product come off the P.C.board.</div> </div> <hr/> <p>5-6. Solder repair by solder iron</p> <p>1) Selection of the soldering iron tip Tip temperature of solder iron varies by its type, P.C.board material and solder land size. The higher the tip temperature, the quicker the operation. However, heat shock may cause a crack in the product. Please make sure the tip temp. before soldering and keep the peak temp and time in accordance with following recommended condition.</p> <p style="text-align: center;">Recommended solder iron condition (Sn-Pb Solder and Lead Free Solder)</p> <table border="1" data-bbox="539 1641 1375 1749"> <thead> <tr> <th>Temp. (°C)</th> <th>Duration (sec.)</th> <th>Wattage (W)</th> <th>Shape (mm)</th> </tr> </thead> <tbody> <tr> <td>350 max.</td> <td>3 max.</td> <td>20 max.</td> <td>Ø 3.0 max.</td> </tr> </tbody> </table> <p>* Please preheat the products with the condition in 5-4 to avoid the thermal shock.</p> <p>2) Direct contact of the soldering iron with ceramic dielectric of products may cause crack. Do not touch the ceramic dielectric and the terminations by solder iron.</p>	Soldering	Temp. (°C)	Reflow soldering	$\Delta T \leq 150$	Manual soldering	$\Delta T \leq 150$	Temp. (°C)	Duration (sec.)	Wattage (W)	Shape (mm)	350 max.	3 max.	20 max.	Ø 3.0 max.
Soldering	Temp. (°C)															
Reflow soldering	$\Delta T \leq 150$															
Manual soldering	$\Delta T \leq 150$															
Temp. (°C)	Duration (sec.)	Wattage (W)	Shape (mm)													
350 max.	3 max.	20 max.	Ø 3.0 max.													

No.	Process	Condition
5	Soldering	<p>5-7. Sn-Zn solder Sn-Zn solder affects product reliability. Please contact TDK in advance when utilize Sn-Zn solder.</p> <p>5-8. Countermeasure for tombstone The misalignment between the mounted positions of the products and the land patterns should be minimized. The tombstone phenomenon may occur especially the products are mounted (in longitudinal direction) in the same direction of the reflow soldering. (Refer to JEITA RCR-2335C Annex A (Informative) Recommendations to prevent the tombstone phenomenon)</p>
6	Cleaning	<p>1) If an unsuitable cleaning fluid is used, flux residue or some foreign articles may stick to product surface to deteriorate especially the insulation resistance.</p> <p>2) If cleaning condition is not suitable, it may damage the product.</p> <p>2)-1. Insufficient washing</p> <p>(1) Terminal electrodes may corrode by Halogen in the flux.</p> <p>(2) Halogen in the flux may adhere on the surface of product, and lower the insulation resistance.</p> <p>(3) Water soluble flux has higher tendency to have above mentioned problems (1) and (2).</p> <p>2)-2. Excessive washing</p> <p>When ultrasonic cleaning is used, excessively high ultrasonic energy output can affect the connection between the ceramic product body and the terminal electrode. To avoid this, following is the recommended condition.</p> <p style="text-align: center;">Power : 20 W/ℓ max. Frequency : 40 kHz max. Washing time : 5 minutes max.</p> <p>2)-3. If the cleaning fluid is contaminated, density of Halogen increases, and it may bring the same result as insufficient cleaning.</p>
7	Coating and molding of the P.C.board	<p>1) When the P.C.board is coated, please verify the quality influence on the product.</p> <p>2) Please verify carefully that there is no harmful decomposing or reaction gas emission during curing which may damage the product.</p> <p>3) Please verify the curing temperature.</p>

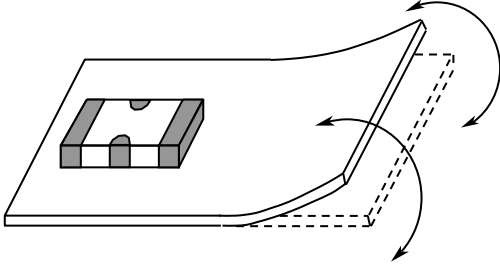
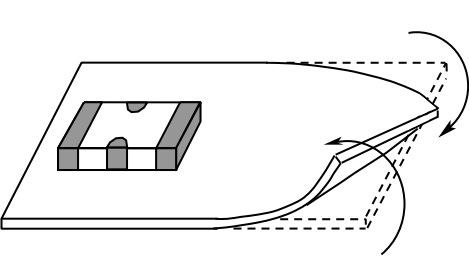
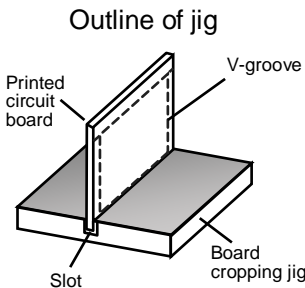
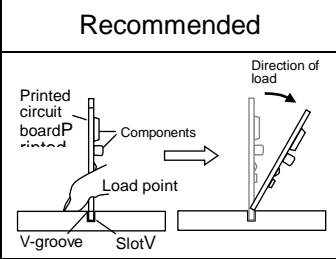
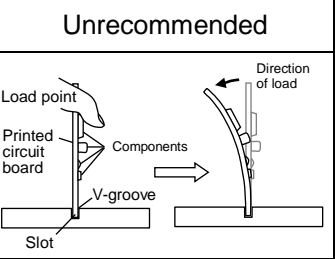
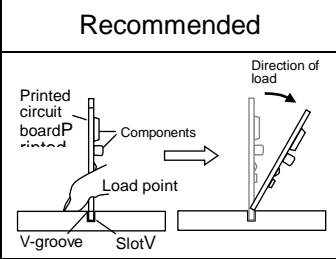
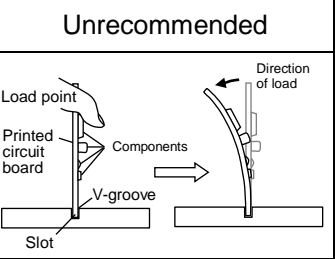
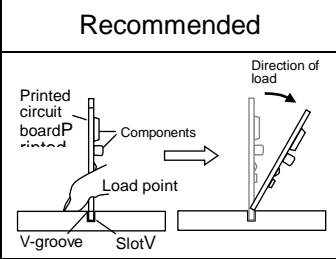
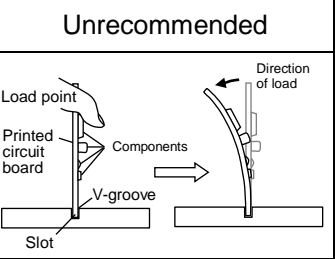
No.	Process	Condition				
8	Handling after chip mounted ⚠ Caution	<p>1) Please pay attention not to bend or distort the P.C.board after soldering in handling otherwise the product may crack.</p> <div style="display: flex; justify-content: space-around; align-items: center;"> <div style="text-align: center;"> <p>Bend</p>  </div> <div style="text-align: center;"> <p>Twist</p>  </div> </div> <p>2) Printed circuit board cropping should not be carried out by hand, but by using the proper tooling. Printed circuit board cropping should be carried out using a board cropping jig as shown in the following figure or a board cropping apparatus to prevent inducing mechanical stress on the board.</p> <p>(1) Example of a board cropping jig</p> <p>Recommended example: The board should be pushed from the back side, close to the cropping jig so that the board is not bent and the stress applied to the product is compressive.</p> <p>Unrecommended example: If the pushing point is far from the cropping jig and the pushing direction is from the front side of the board, large tensile stress is applied to the product, which may cause cracks.</p> <div style="display: flex; align-items: flex-start;"> <div style="margin-right: 20px;"> <p>Outline of jig</p>  </div> <table border="1" style="border-collapse: collapse;"> <thead> <tr> <th style="padding: 5px;">Recommended</th> <th style="padding: 5px;">Unrecommended</th> </tr> </thead> <tbody> <tr> <td style="padding: 5px;">  </td> <td style="padding: 5px;">  </td> </tr> </tbody> </table> </div>	Recommended	Unrecommended		
Recommended	Unrecommended					
						

No.	Process	Condition
-----	---------	-----------

8 Handling after chip mounted
 ⚠ Caution

(2) Example of a board cropping machine

An outline of a printed circuit board cropping machine is shown below. The top and bottom blades are aligned with one another along the lines with the V-grooves on printed circuit board when cropping the board.
 Unrecommended example: Misalignment of blade position between top and bottom, right and left, or front and rear blades may cause a crack in the product.

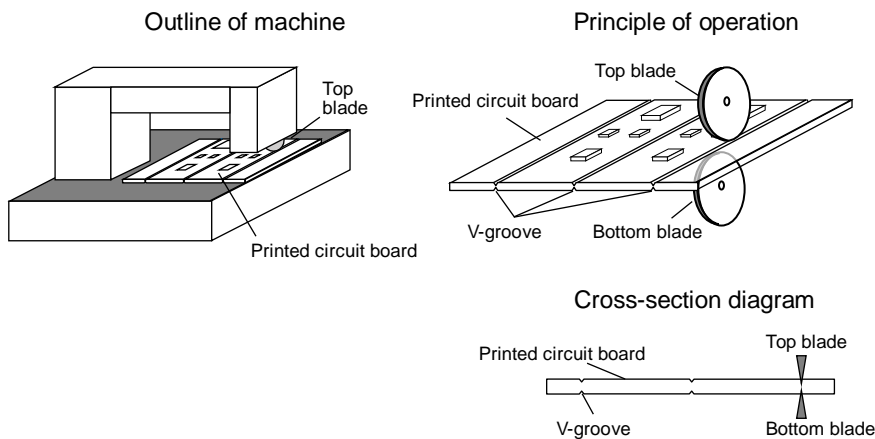

Recommended	Unrecommended		
	Top-bottom misalignment	Left-right misalignment	Front-rear misalignment
<p>Top blade</p> <p>Board</p> <p>Bottom blade</p>	<p>Top blade</p> <p>Bottom blade</p>	<p>Top blade</p> <p>Bottom blade</p>	<p>Top blade</p> <p>Bottom blade</p>

3) When functional check of the P.C.board is performed, check pin pressure tends to be adjusted higher for fear of loose contact. But if the pressure is excessive and bend the P.C.board, it may crack the product or peel the terminations off. Please adjust the check pins not to bend the P.C.board.

Item	Not recommended	Recommended
Board bending	<p>Termination peeling</p> <p>Check pin</p>	<p>Support pin</p> <p>Check pin</p>

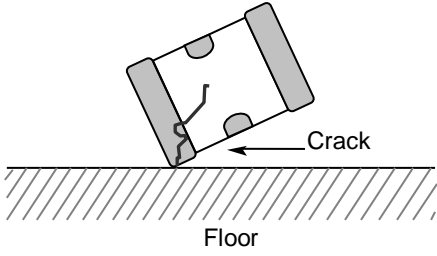
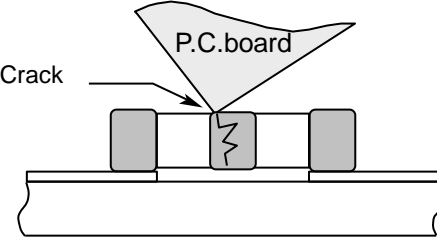
No.	Process	Condition
9	Handling of loose product	<p>1) If dropped the product may crack. Once dropped do not use it. Especially, the large case sized product are tendency to have cracks easily, so please handle with care.</p>  <p>2) Piling the P.C.board after mounting for storage or handling, the corner of the P.C. board may hit the product of another board to cause crack.</p> 
10	Caution during operation of equipment	<p>1) A product shall not be touched directly with bare hands during operation in order to avoid electric shock. Electric energy held by the product may be discharged through the human body when touched with a bare hand. Even when the equipment is off, a product may stay charged. The product should be handled after being completely discharged using a resistor.</p> <p>2) The terminals of a product shall not be short-circuited by any accidental contact with a conductive object. A product shall not be exposed to a conductive liquid such as an acid or alkali solution. A conductive object or liquid, such as acid and alkali, between the terminals may lead to the breakdown of a product due to short circuit</p> <p>3) Confirm that the environment to which the equipment will be exposed during transportation and operation meets the specified conditions. Do not to use the equipment in the following environments.</p> <ul style="list-style-type: none"> (1) Environment where a product is splattered with water or oil (2) Environment where a product is exposed to direct sunlight (3) Environment where a product is exposed to Ozone, ultraviolet rays or radiation (4) Environment where a product exposed to corrosive gas(e.g. hydrogen sulfide, sulfur dioxide, chlorine. ammonia gas etc.) (5) Environment where a product exposed to vibration or mechanical shock exceeding the specified limits. (6) Atmosphere change with causes condensation

No.	Process	Condition
11	Others  Caution	<p>The product listed in this specification is intended for use in automotive applications under-normal operation and usage conditions.</p> <p>The product is not designed or warranted to meet the requirements of application listed below, whose performance and/or quality requires a more stringent level of safety or reliability, or whose failure, malfunction or defect could cause serious damage to society, person or property. Please understand that we are not responsible for any damage or liability caused by use of the products in any of the applications below or for any other use exceeding the range or conditions set forth in this specification sheet. If you intend to use the products in the applications listed below or if you have special requirements exceeding the range or conditions set forth in this specification, please contact us.</p> <ul style="list-style-type: none"> (1) Aerospace/Aviation equipment (2) Transportation equipment (electric trains, ships etc.) (3) Medical equipment (Excepting Pharmaceutical Affairs Law classification Class1, 2) (4) Power-generation control equipment (5) Atomic energy-related equipment (6) Seabed equipment (7) Transportation control equipment (8) Public information-processing equipment (9) Military equipment (10) Electric heating apparatus, burning equipment (11) Disaster prevention/crime prevention equipment (12) Safety equipment (13) Other applications that are not considered general-purpose applications <p>When designing your equipment even for general-purpose applications, you are kindly requested to take into consideration securing protection circuit/device or providing backup circuits in your equipment.</p> <p>In addition, although the product listed in this specification is intended for use in automotive applications as described above, it is not prohibited to use for general electronic equipment, whose performance and/or quality doesn't require a more stringent level of safety or reliability, or whose failure, malfunction or defect could not cause serious damage to society, person or property.</p> <p>Therefore, the description of this caution will be applied, when the product is used in general electronic equipment under a normal operation and usage conditions.</p>

12. TAPE PACKAGING SPECIFICATION

1. CONSTRUCTION AND DIMENSION OF TAPING

1-1. Dimensions of carrier tape

Dimensions of paper tape shall be according to Appendix 3.

Dimensions of plastic tape shall be according to Appendix 4.

1-2. Bulk part and leader of taping

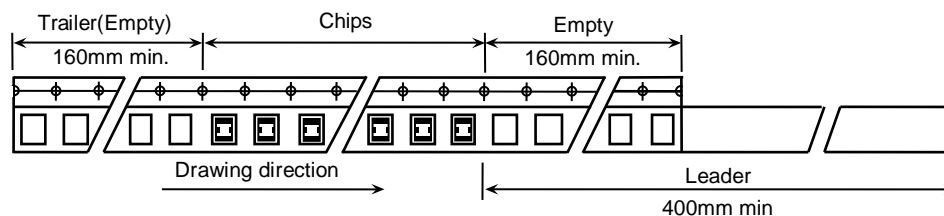

1-3. Dimensions of reel

Dimensions of $\phi 178$ reel shall be according to Appendix 5.

Dimensions of $\phi 330$ reel shall be according to Appendix 6.

1-4. Structure of taping

<Paper>

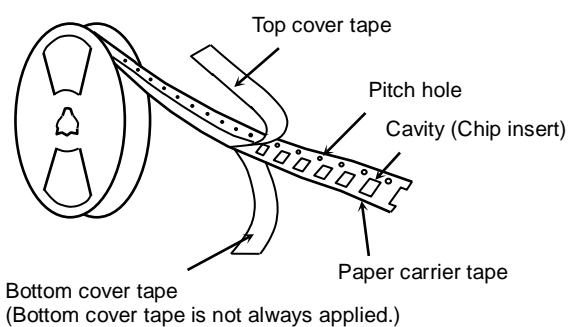

<Plastic>

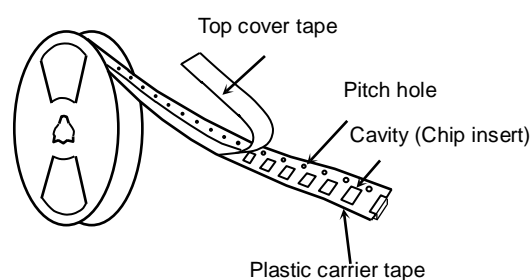

2. PRODUCT QUANTITY

Please refer to detail page on TDK web.

3. PERFORMANCE SPECIFICATIONS

3-1. Fixing peeling strength (top tape)
 $0.05\text{N} < \text{Peeling strength} < 0.7\text{N}$

<Paper>

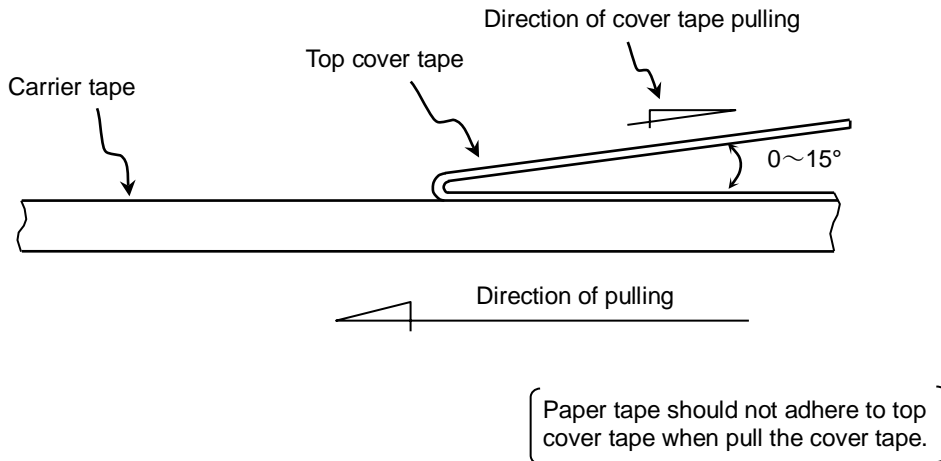

<Plastic>

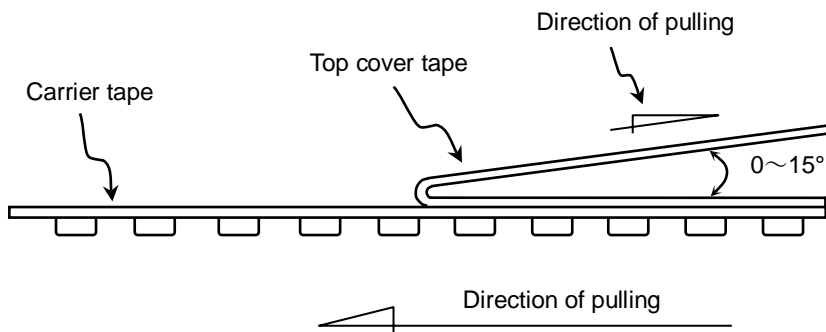

3-2. Carrier tape shall be flexible enough to be wound around a minimum radius of 30mm with components in tape.

3-3. The missing of components shall be less than 0.1%

3-4. Components shall not stick to fixing tape.

3-5. When removing the cover tape, there shall not be difficulties by unfitting clearance gap, burrs and crushes of cavities. Also the sprocket holes shall not be covered by absorbing dust into the suction nozzle.

Appendix 3

Paper Tape

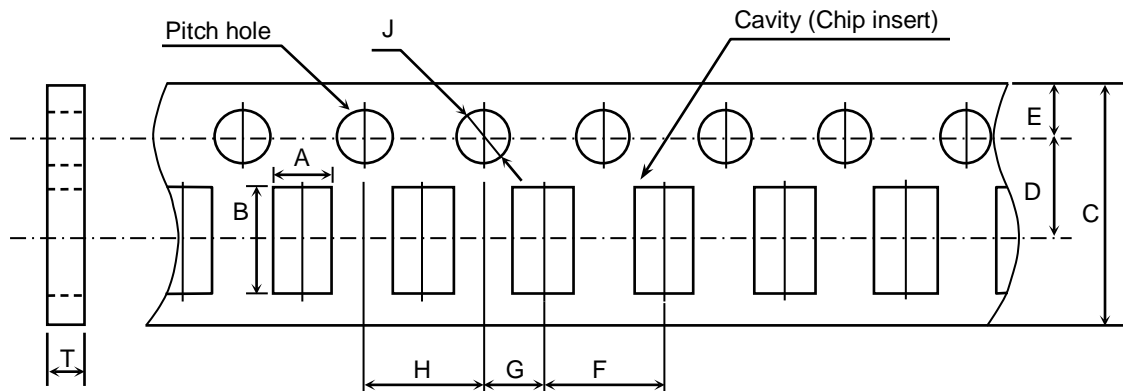

(Unit : mm)

Symbol Type	A	B	C	D	E	F
YFF18	(1.10)	(1.90)	8.00 ± 0.30	3.50 ± 0.05	1.75 ± 0.10	4.00 ± 0.10
YFF21	(1.50)	(2.30)				

Symbol Type	G	H	J	T
YFF18	2.00 ± 0.05	4.00 ± 0.10	∅ 1.5 ^{+0.10} ₀	1.20 max.
YFF21				

() Reference value.

Appendix 4

Plastic Tape

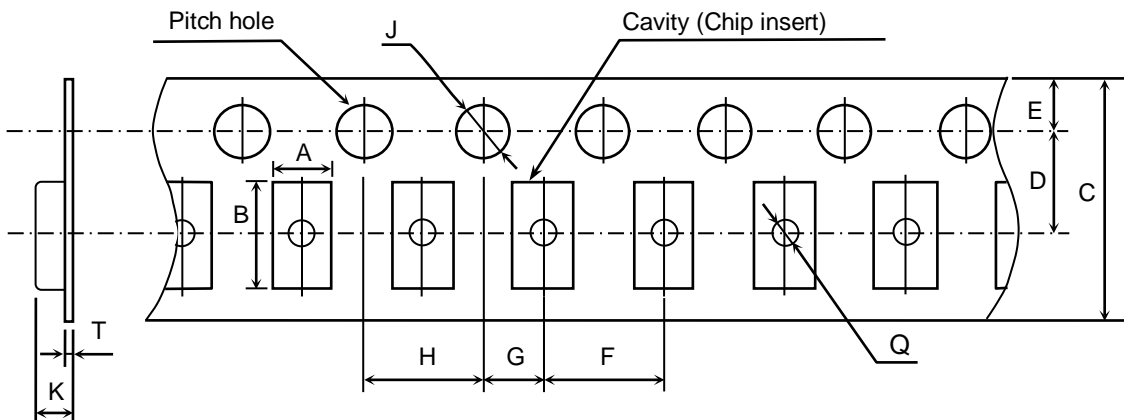

(Unit : mm)

Symbol Type	A	B	C	D	E	F
YFF31	(1.90)	(3.50)	8.00±0.30	3.50±0.05	1.75±0.10	4.00±0.10
Symbol Type	G	H	J	K	T	Q
YFF31	2.00±0.05	4.00±0.10	$\phi 1.5 \begin{matrix} +0.10 \\ 0 \end{matrix}$	2.50 max.	0.30 max.	$\phi 0.50$ min.

() Reference value.

Appendix 5
 Dimensions of reel (Material : Polystyrene)

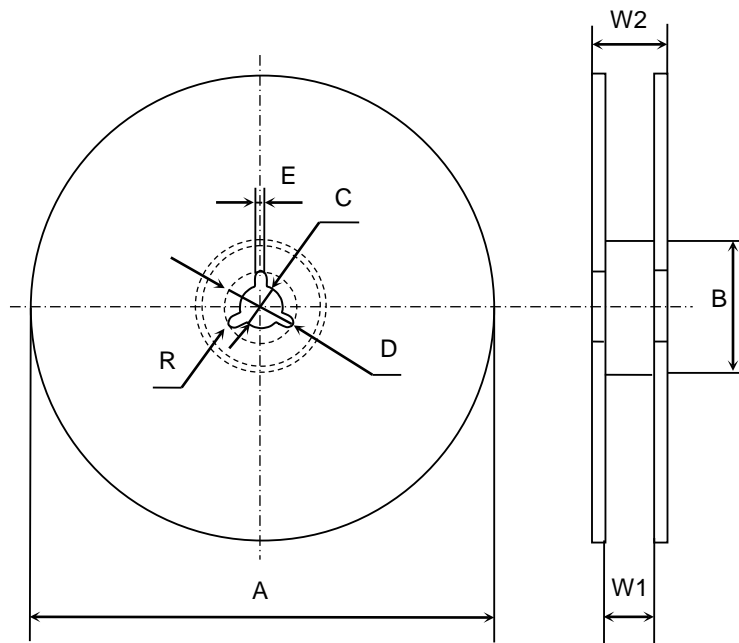

(Unit : mm)

Symbol	A	B	C	D	E	W1
Dimension	$\phi 178 \pm 2.0$	$\phi 60 \pm 2.0$	$\phi 13 \pm 0.5$	$\phi 21 \pm 0.8$	2.0 ± 0.5	9.0 ± 0.3
Symbol	W2	R				
Dimension	13.0 ± 1.4	1.0				

Appendix 6
 Dimensions of reel (Material : Polystyrene)

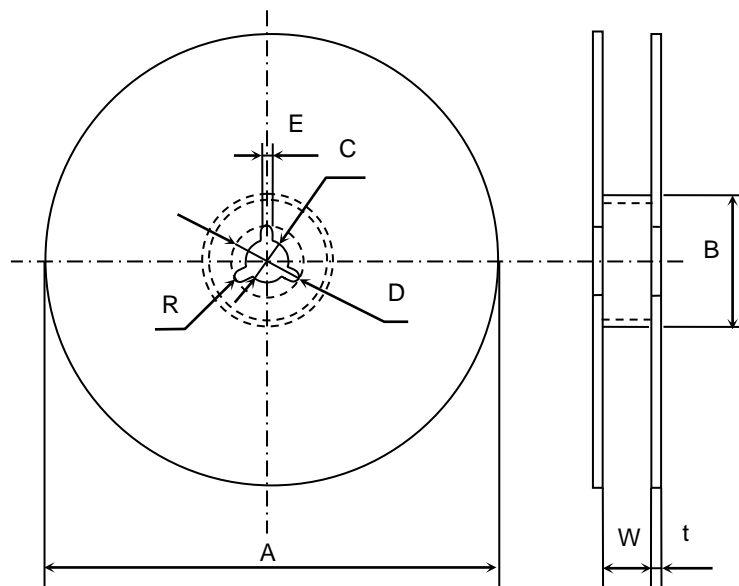

(Unit : mm)

Symbol	A	B	C	D	E	W
Dimension	$\phi 382$ max. (Nominal $\phi 330$)	$\phi 50$ min.	$\phi 13 \pm 0.5$	$\phi 21 \pm 0.8$	2.0 ± 0.5	10.0 ± 1.5
Symbol	t	R				
Dimension	2.0 ± 0.5	1.0				