

XS7C4A1MPN12

inductive sensor XS7 40x40x117 - PBT - Sn15 mm - 24..240VAC/DC - terminals



Main

Range of product	OsiSense XS
Series name	General purpose
Sensor type	Inductive proximity sensor
Device application	-
Sensor name	XS7
Sensor design	Form 40 x 40 x 117
Size	117 mm
Body type	Fixed
Detector flush mounting acceptance	Flush mountable
Material	Plastic
Enclosure material	PBT
Type of output signal	Discrete
Wiring technique	2-wire
[Sn] nominal sensing distance	15 mm
Discrete output function	1 NO or 1 NC programmable
Output circuit type	AC/DC
Electrical connection	Screw-clamp terminals, clamping capacity: 4 x 1.5 mm ²
[Us] rated supply voltage	24...240 V AC 50/60 Hz 24...240 V DC
Switching capacity in mA	5...200 mA DC 5...300 mA AC
IP degree of protection	IP67 conforming to IEC 60529 IP65 conforming to IEC 60529 IP69K conforming to DIN 40050

Complementary

Detection face	5 positions turret head
Front material	PBT
Operating zone	0...12 mm
Differential travel	3...15% of Sr
Repeat accuracy	<= 3% of Sr
Cable entry number	1 tapped entry for 1/2" NPT cable gland
Status LED	1 LED green for supply on 1 LED yellow for output state
Supply voltage limits	20...264 V AC/DC
Residual current	<= 1.5 mA for open state 120 V <= 0.6 mA for open state 24 V
Switching frequency	<= 25 Hz AC <= 50 Hz DC
Voltage drop	<= 5.5 V at closed state
Delay first up	<= 7.5 ms
Delay response	<= 1.2 ms
Delay recovery	<= 1.8 ms
Marking	CE
Height	40 mm

Length	40 mm
Width	117 mm
Product weight	0.244 kg

Environment

Product certifications	CCC CSA UL
Ambient air temperature for operation	-25...70 °C
Ambient air temperature for storage	-40...85 °C
Vibration resistance	25 gn amplitude = +/- 2 mm (f = 10...55 Hz) conforming to IEC 60068-2-6
Shock resistance	50 gn for 11 ms conforming to EN 60068-2-27

Offer Sustainability

Sustainable offer status	Green Premium product
RoHS (date code: YYWW)	Compliant - since 1213 - Schneider Electric declaration of conformity
REACH	Reference not containing SVHC above the threshold
Product environmental profile	Available Download Product Environmental
Product end of life instructions	Need no specific recycling operations

Dimensions

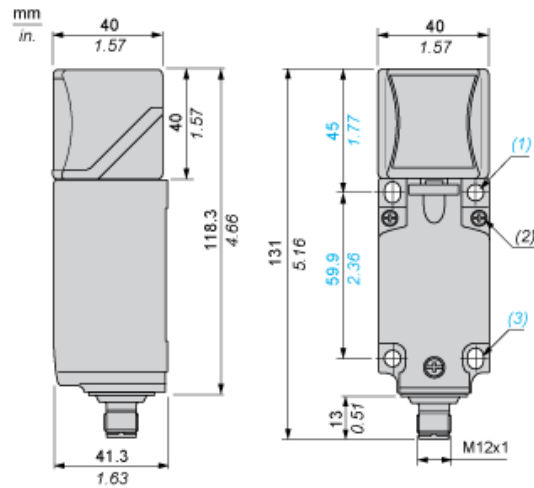

- (1) 2 holes \varnothing 5,45 mm / \varnothing 0.21 in. (Tightening torque: < 1,5 Nm / < 13.3 lb-in.)
- (2) 3 screws M3,5. (Tightening torque: < 1,2 Nm / < 10.6 lb-in.)
- (3) 2 elongated holes 5,4 x 7,4 mm / 0.21 x 0.29 in. (Tightening torque: < 1,5 Nm / < 13.3 lb-in.)

Mounting

Head Positions

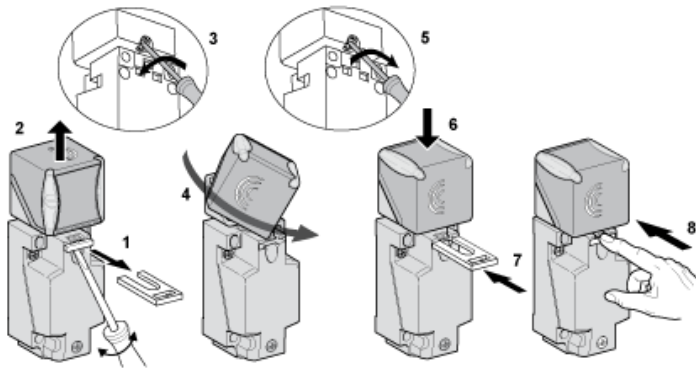

Setting-up Precautions

Minimum Mounting Distances (mm)

Side by Side

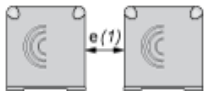

$e(1) \geq 60$

Face to Face

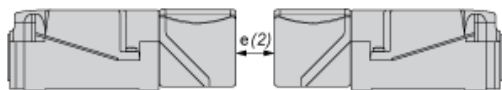

$e(2) \geq 120$

Facing a Metal Object

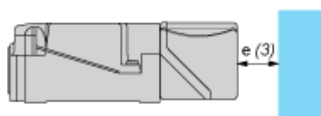

$e(3) \geq 45$

Wiring Schemes

2-Wire AC or DC (Programmable)

