

XPSUDN13AP

Safety module, Harmony Safety Automation, Cat.4, features 6*XPSUAF, 24v AC/DC, screw



Main

Range of product	Harmony Safety Automation
Product or component type	Safety module
Safety module name	XPSUDN
Safety module application	Monitoring antivalent contacts For emergency stop, guard and light curtain monitoring
Function of module	Emergency stop button with 2 NC contacts Guard monitoring with 1 or 2 limit switches Monitoring 2 PNP sensors Magnetic switch monitoring Light curtain monitoring RFID switch Monitoring of electro-sensitive protection equipment (ESPE) Proximity sensor monitoring
Safety level	Can reach PL e/category 4 for normally open relay contact conforming to ISO 13849-1 Can reach SILCL 3 for normally open relay contact conforming to IEC 62061 Can reach SIL 3 for normally open relay contact conforming to IEC 61508 Can reach PL c/category 1 for normally closed relay contact conforming to ISO 13849-1 Can reach SILCL 1 for normally closed relay contact conforming to IEC 62061 Can reach SIL 1 for normally closed relay contact conforming to IEC 61508
Safety reliability data	MTTFd > 30 years conforming to ISO 13849-1 Dcavg >= 99 % conforming to ISO 13849-1 PFHd = 0.88E-09 conforming to ISO 13849-1 HFT = 1 conforming to IEC 62061 PFHd = 0.88E-09 conforming to IEC 62061 SFF > 99% conforming to IEC 62061 HFT = 1 conforming to IEC 61508-1 PFHd = 0.88E-09 conforming to IEC 61508-1 SFF > 99% conforming to IEC 61508-1 Type = B conforming to IEC 61508-1
Electrical circuit type	NC pair PNP pair Antivalent pair OSSD pair
Connections - terminals	Removable screw terminal block, 0.2...2.5 mm ² solid or flexible Removable screw terminal block, 0.25...2.5 mm ² flexible with ferrule single conductor Removable screw terminal block, 0.2...1.5 mm ² solid or flexible twin conductor Removable screw terminal block, 2 x 0.25...1 mm ² flexible with ferrule without cable end, with bezel Removable screw terminal block, 2 x 0.5...1.5 mm ² flexible with ferrule with cable end, with bezel
[Us] rated supply voltage	24 V AC - 15...10 % 24 V DC - 20...20 %

The information provided in this documentation contains general descriptions and/or technical characteristics of the performance of the products contained herein. This documentation is not intended as a substitute for and is not to be used for determining suitability or reliability of these products for specific user applications. It is the duty of any such user or integrator to perform the appropriate and complete risk analysis, evaluation and testing of the products with respect to the relevant specific application or use thereof. Neither Schneider Electric Industries SAS nor any of its affiliates or subsidiaries shall be responsible or liable for misuse of the information contained herein.

Complementary

Synchronisation time between inputs	0.5 s 2 s 2.2 s 4 s
Type of start	Automatic/manual/monitored
Power consumption in W	4.5 W 24 V DC
Power consumption in VA	10.5 VA 24 V AC 50/60 Hz
Input protection type	Internal, electronic
Safety outputs	3 NO + 1 NC
Safety inputs	6 safety input 24 V DC 5 mA
Maximum wire resistance	500 Ohm
Input compatibility	Normally closed circuit conforming to ISO 14119 XC limit switch conforming to ISO 14119 Mechanical contact conforming to ISO 14119 Normally closed circuit conforming to ISO 13850 Antivalent pair conforming to ISO 14119 OSSD pair conforming to IEC 61496-1-2 3-wire proximity sensors PNP
[Ie] rated operational current	5 A AC-1 for normally open relay contact 3 A AC-15 for normally open relay contact 5 A DC-1 for normally open relay contact 3 A DC-13 for normally open relay contact 3 A AC-1 for normally closed relay contact 1 A AC-15 for normally closed relay contact 3 A DC-1 for normally closed relay contact 1 A DC-13 for normally closed relay contact
Control outputs	7 on/off configurable pulsed output
Input/output type	Semiconductor pulsed diagnostic output 24 V DC, 20 mA Z1, not safety-related
[Ith] conventional free air thermal current	16 A
Associated fuse rating	10 A gG for NO relay output circuit conforming to IEC 60947-1 4 A gG for NC relay output circuit conforming to IEC 60947-1
Minimum output current	10 mA for relay output
Minimum output voltage	12 V for relay output
Maximum response time on input open	20 ms
[Ui] rated insulation voltage	250 V (pollution degree 2) conforming to EN/IEC 60947-1
[Uimp] rated impulse withstand voltage	4 kV overvoltage category II conforming to EN/IEC 60947-1
Local signalling	LED (green) for power ON LED (red) for error LED (yellow) for start LED (yellow) for safety status LED (yellow) for safety input S12 LED (yellow) for safety input S13 LED (yellow) for safety input S22 LED (yellow) for safety input S23 LED (yellow) for safety input S32 LED (yellow) for safety input S33 LED (yellow) for safety input S42 LED (yellow) for safety input S43 LED (yellow) for safety input S52 LED (yellow) for safety input S53 LED (yellow) for safety input S62 LED (yellow) for safety input S73
Mounting support	35 mm symmetrical DIN rail
Depth	120 mm
Height	100 mm
Width	45 mm
Net weight	0.350 kg







Environment

Standards	IEC 60947-5-1 IEC 61508-1 functional safety standard IEC 61508-2 functional safety standard IEC 61508-3 functional safety standard IEC 61508-4 functional safety standard IEC 61508-5 functional safety standard IEC 61508-6 functional safety standard IEC 61508-7 functional safety standard ISO 13849-1 functional safety standard IEC 62061 functional safety standard
Product certifications	TÜV cULus
IP degree of protection	IP20 (terminals) conforming to EN/IEC 60947-1 IP40 (housing) conforming to EN/IEC 60947-1 IP54 (mounting area) conforming to EN/IEC 60947-1
Ambient air temperature for operation	-25...50 °C at 24 V AC -25...55 °C at 24 V DC
Ambient air temperature for storage	-25...85 °C
Relative humidity	5...95 % non-condensing

Packing Units

Unit Type of Package 1	PCE
Number of Units in Package 1	1
Package 1 Height	13.5 cm
Package 1 Width	13.5 cm
Package 1 Length	13.5 cm
Package 1 Weight	450 g
Unit Type of Package 2	S03
Number of Units in Package 2	16
Package 2 Height	30 cm
Package 2 Width	30 cm
Package 2 Length	40 cm
Package 2 Weight	7.801 kg

Offer Sustainability

Sustainable offer status	Green Premium product
REACH Regulation	 REACH Declaration
EU RoHS Directive	Pro-active compliance (Product out of EU RoHS legal scope)  EU RoHS Declaration
Mercury free	Yes
China RoHS Regulation	 China RoHS Declaration
RoHS exemption information	 Yes
Environmental Disclosure	 Product Environmental Profile
Circularity Profile	 End Of Life Information
WEEE	The product must be disposed on European Union markets following specific waste collection and never end up in rubbish bins
PVC free	Yes

Contractual warranty

Warranty	18 Monate
----------	-----------

Dimensions

Front and Side Views

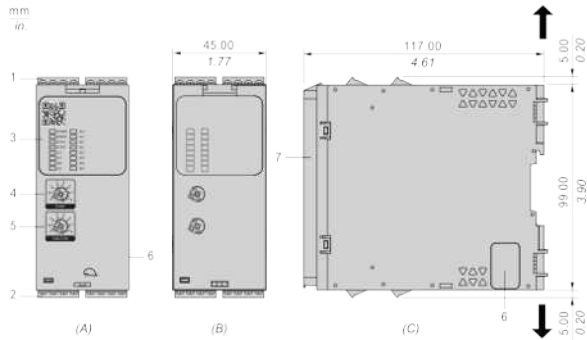

- (A) : Product drawing
- (B) : Screw clamp terminal
- (C) : Side view
- (1) : Removable terminal blocks, top
- (2) : Removable terminal blocks, bottom
- (3) : LED indicators
- (4) : Start function selector
- (5) : Function selector
- (6) : Connector for optional output extension module (lateral)
- (7) : Sealable transparent cover

mm in.	7.0-8.0 0.28-0.31					
mm ²	0,2... 2,5	0,25...2,5	0,2...1,5	0,25...1	0,5...1,5	
AWG	24... 12	24...12	24...16	24...18	20...16	
	Ø 3,5 mm (0.14 in)			Nm	0.5... 0.6	
				lb-in	4,4... 5,3	

Mounting to DIN rail

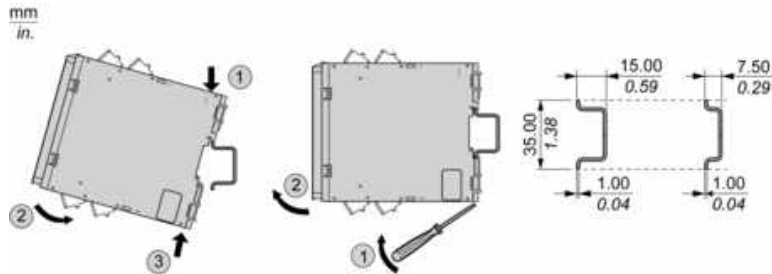

Screw-mounting

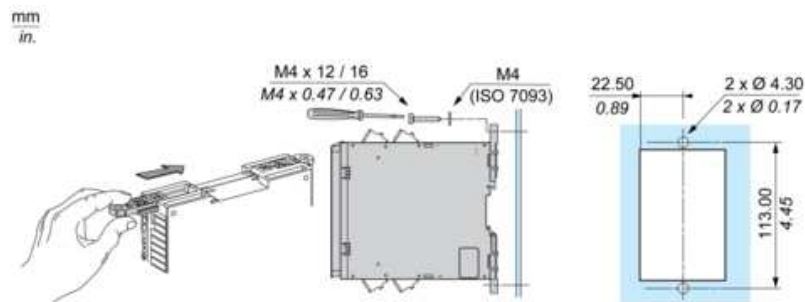

Wiring Drawing

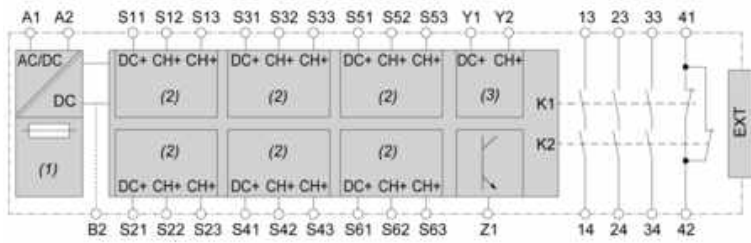

(1) : A1-A2 (Power supply)

(2) : S11-S12-S13-S31-S32-S33-S51-S52-S53-S21-S22-S23-S41-S42-S43-S61-S62-S63 (Single-channel safety input)

(3) : Y1-Y2 (Start)

13-23-33-41-14-24-34-42 : Output

EXT : Connector for optional extension module

B2 : Common ground terminal

Z1 : Pulsed output for diagnostics, not safety-related