



Micro Battery

Product Catalogue

2013 ▶ 2014



Low ESR, Low leak current Chip-type EDLC

CPX3225A series

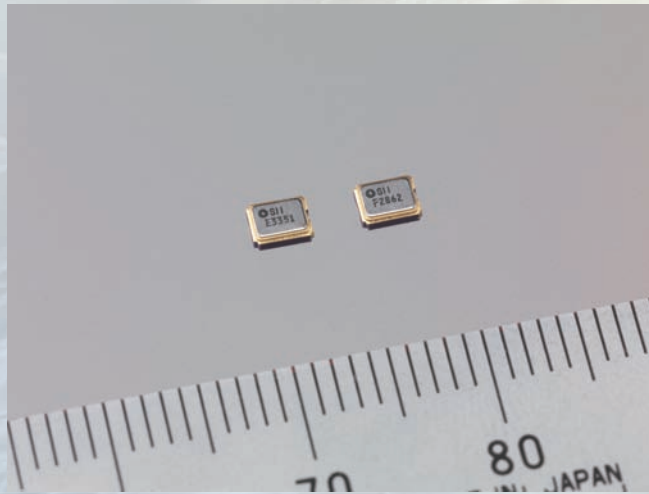

Features

◆ **Large discharge current and super rapid charging achieved by low internal resistance**

Reduced internal resistance to 25 ohms, one-third that of the conventional EDLCs, allows discharge current of up to several tens of mAs and rapid charging within a few seconds.

◆ **Chargeable by slight power, thanks to low leak current**

Reduced leak current to about 10 nA level, approximately one-tenth that of the conventional EDLCs, allows sufficient charging with several micro Watts from a slight energy harvesting power source.

Application Examples

- Electric storage device for energy harvesting
- Power source or Electric storage for Wireless Sensor Network, RFID tag, RF remote control for digital home electrical appliance
- Power source or Electric storage for Contactless IC card, multi-functional IC card
- Instant back-up for CPU or DRAM and power source for saving data on flash memory

Specifications

Part number	Maximum use voltage	Capacitance	Internal impedance	Size (L x W x H)	Weight
CPX3225A252D	2.6V	2.5mF	25Ω	3.2 x 2.5 x 0.9mm	0.024g
CPX3225A752D	2.6V	7.5mF	25Ω	3.2 x 2.5 x 0.9mm	0.024g



A few decades ago, we commercialized a highly reliable silver oxide battery to meet the requirement of quartz watch development. Since then, we have expanded our microbattery offering and technology to support the increased diversity in electronic products available today.

This brochure introduces manganese silicon lithium rechargeable batteries, titanium silicon lithium rechargeable batteries, and reflowable capacitors.

We plan to continuously develop higher performance microbatteries and widen our products lineup to keep up with our emerging technologies.

Please feel free to contact us with any questions you may have.

FEATURES

1. Superior leakage resistance

Even a slight leakage from a battery may interfere with the connections made by the battery terminals, resulting in unstable device operation. Seiko Instruments Inc. offers micro batteries that are highly leak-resistant due to special sealing materials and processing technologies.

2. Large capacity

In order to extend the operating time of devices with limited battery space, the market demands high volumetric efficiency. We offer large-capacity microbatteries developed with proprietary technology utilizing high-purity materials.

3. Stable operating voltage

Carefully compounded ingredients allow each of our micro batteries to have a stable operating voltage over both a wide temperature range and depth of discharge.

4. High reliability

Our micro batteries are manufactured under an integrated system featuring strict quality control, which starts with component manufacturing, through assembly and on to rigorous out-going inspection.

CONTENTS

CPX3225A	2
Microbattery and Capacitor Lineup	4
MS Lithium Rechargeable Battery.....	6
TS Lithium Rechargeable Battery	10
Chip type Electric Double Layer Capacitor	12
XH Capacitor	14
Selection Check Sheet	17
Environmental Activities	20
Precautions for Your Safety	21

Microbattery and Capacitor Lineup

MICROBATTERY AND CAPACITOR FEATURES

- Chip type electric double layer capacitor** : Small and thin size chip type Electric Double Layer Capacitor.
- XH capacitor** : Pb-free reflowable capacitor made possible by a heat-resistant design. High capacity and long cycle characteristics are offered.
- MS lithium rechargeable battery** : 3V type. Large capacity and high cycle life characteristics in a compact body with excellent overdischarge characteristics featured.
- TS lithium rechargeable battery** : 1.5V type. Charge voltage range from 1.5V to 3.0V is supported while high reliability is achieved.

Rechargeable battery and capacitor sizes

*The rectangle and circles in the table show actual battery and capacitor sizes.

Height	2.1mm				MS621FE TS621E	MS920SE TS920E
	1.8mm			MS518SE		
	1.4mm		MS414GE XH414HG		MS614SE	
	1.2mm		MS412FE			
	1.1mm		XH311HU XH311HG			
	0.9mm	CPH3225A				
	Chip type 3.2mm × 2.5mm	Φ3.8mm	Φ4.8mm	Φ5.8mm	Φ6.8mm	Φ9.5mm
		SIZE Diameter				

Applications



Example of a recommended application circuit: for RTC backup

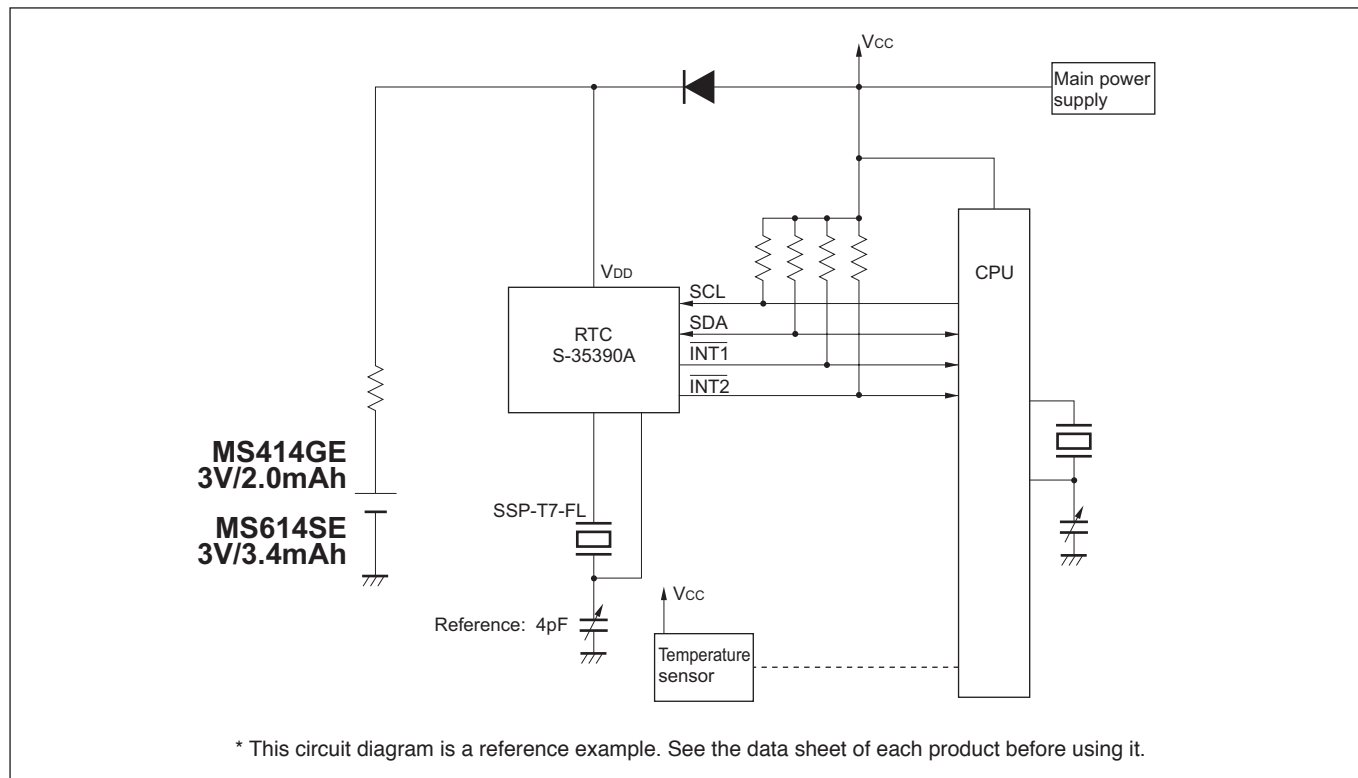

Example of RTC backup time, using MS414GE/MS614SE

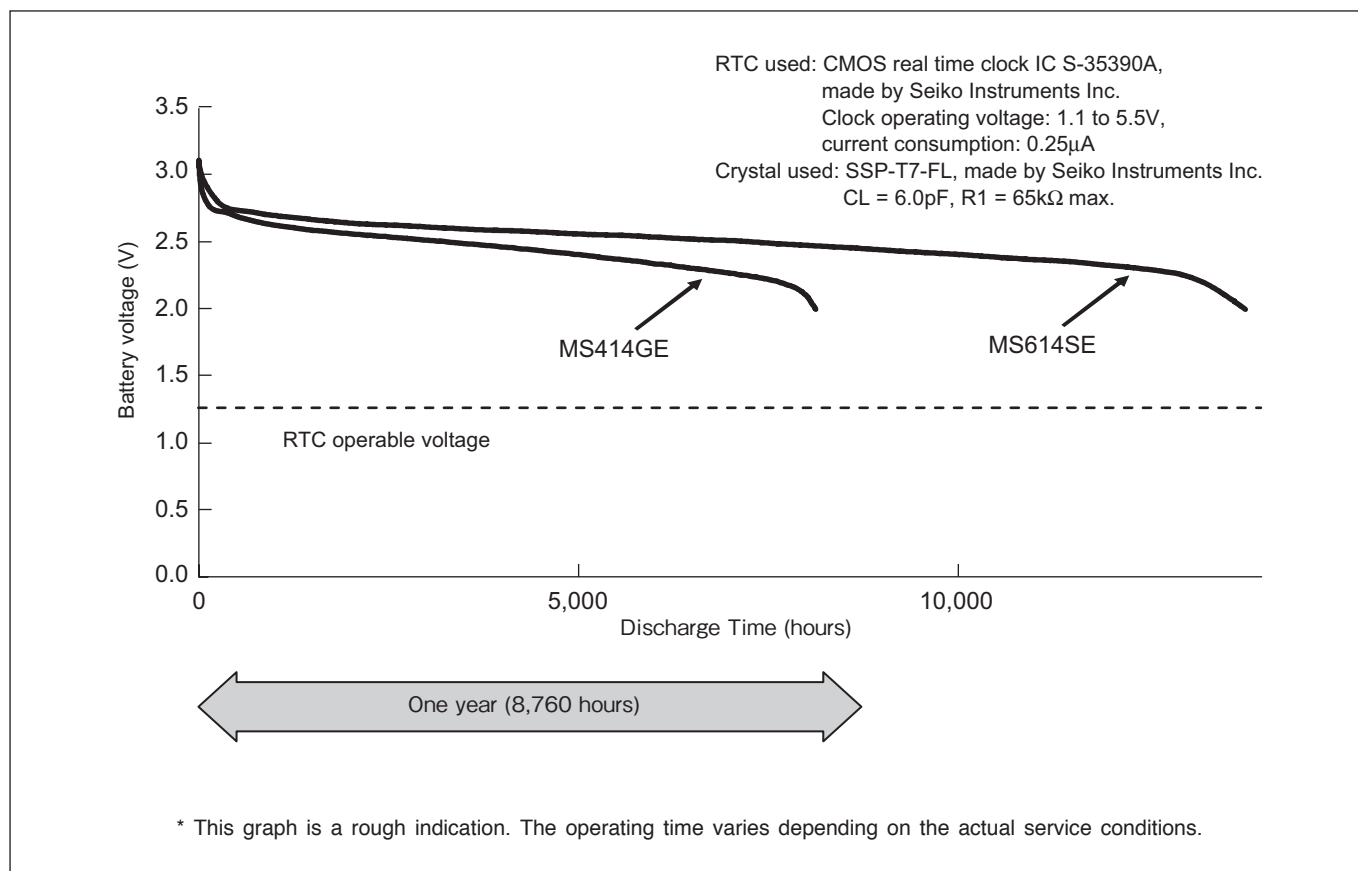

MS414GE / MS412FE / MS518SE / MS614SE / MS621FE / MS920SE



MS (Manganese Silicon) lithium rechargeable batteries, developed by Seiko Instruments Inc., use silicon oxide as the anode and a lithium manganese composite oxide as the cathode. As a result, they offer long cycle life and highly stable overdischarge characteristics.

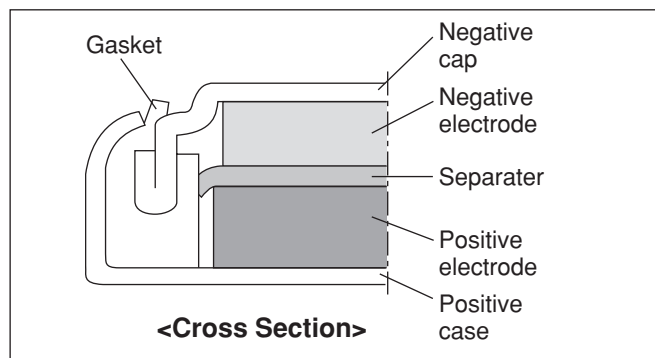

FEATURES

- Large discharge capacity :
For high operational voltage range of 3.3V to 2.0V.
- Long cycle life :
Cycle life of over 100 cycles (over 50 cycles for MS414GE) under charge/discharge conditions of 3.3V to 2.0V (D.O.D.100%).
- Excellent overdischarge characteristics :
Continued stable capacity characteristics even after the battery is overdischarged down to 0.0V.
- Operation over a wide temperature range:
Operating temperature range : -20°C to +60°C
Consult us for using the battery at a temperature beyond the above temperature range.
- RoHS Compliant
- Approved by UL (Underwriters Laboratories Inc.)
UL File No. MH15628

APPLICATIONS

- Backup power supply for memory or clock function in various types of electronic equipment for mobile communication, office automation, audio-visual equipment, mobile information equipment, etc. (smartphone, tablet, cellphone, PHS, cordless phone, pager, fax machine, PC, video camera, digital camera, tuner, handy terminal, etc.)
- Main power supply for small and slim portable equipment.

SPECIFICATIONS

Type	Nominal Voltage (V)	Charge Voltage (Standard Charge Voltage)*6 (V)	Nominal Capacity (mAh)*11	Internal Impedance (Ω)*2	Standard Charge/Discharge Current (mA)	Maximum Discharge Current (Continuous) (mA)*3	Cycle Life (Time)*4		Size (mm)		Weight (g)
							100%*5 D.O.D. (Depth of Discharge)	20%*5 D.O.D. (Depth of Discharge)	Diameter	Height	
MS414GE	3	2.8 to 3.3 (3.1)	2.0	100	0.010	0.05	50	500	4.8	1.4	0.08
MS412FE	3	2.8 to 3.3 (3.1)	1.0	100	0.010	0.10	100	1000	4.8	1.2	0.07
MS518SE	3	2.8 to 3.3 (3.1)	3.4	60	0.010	0.15	100	1000	5.8	1.8	0.13
MS614SE	3	2.8 to 3.3 (3.1)	3.4	80	0.015	0.25	100	1000	6.8	1.4	0.17
MS621FE	3	2.8 to 3.3 (3.1)	5.5	80	0.015	0.25	100	1000	6.8	2.1	0.23
MS920SE	3	2.8 to 3.3 (3.1)	11.0	35	0.050	0.80	100	1000	9.5	2.1	0.47

*1. Nominal capacity: Typical value of discharge capacity between 3.1V and 2.0V

*2. Internal impedance is measured using an AC (Alternating Current) method at the fully charged state.

*3. Maximum discharge current indicates the value of a current for approximately 50% of the nominal capacity.

*4. Cycle Life indicates the times charge/discharge is repeated for approximately 50% of the capacity values in the specification sheet.

*5. 100% and 20% are based on nominal capacity.

*6. A constant voltage charge is recommended, but due to a limit in charge current, it is necessary to insert a resistor to regulate the charge current.

Contact us for further details.

If a constant current charge is required, contact us for more information.

MS Lithium Rechargeable Batteries are not reflowable. Please mount them on PCB by hand soldering.

DISCHARGE CHARACTERISTICS (CHARGE VOLTAGE DEPENDENCE)

MS414GE

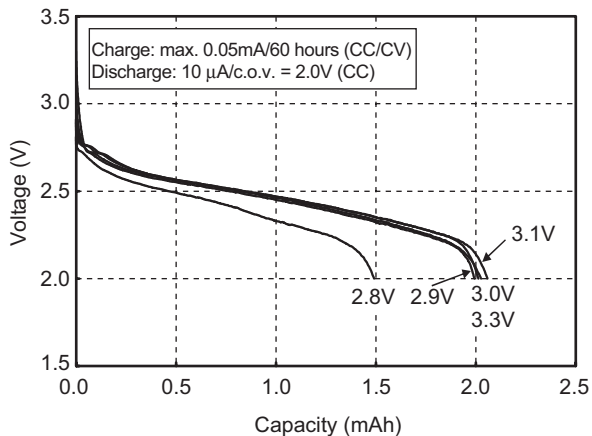

MS412FE

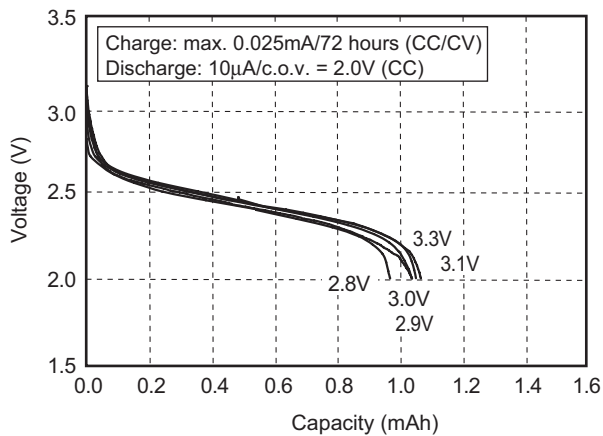

MS518SE

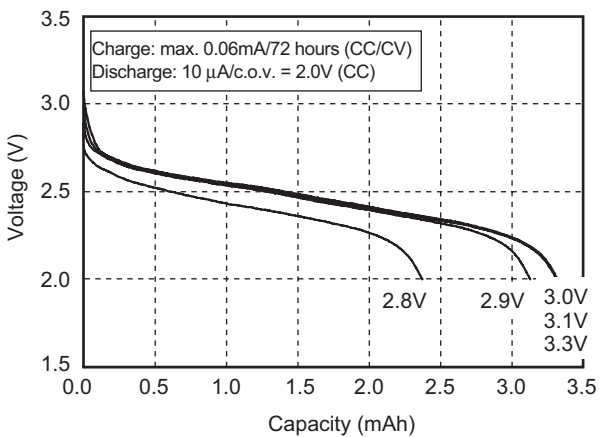

MS614SE

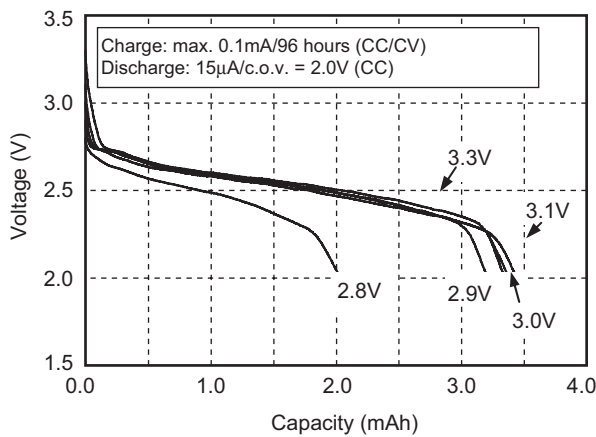

MS621FE

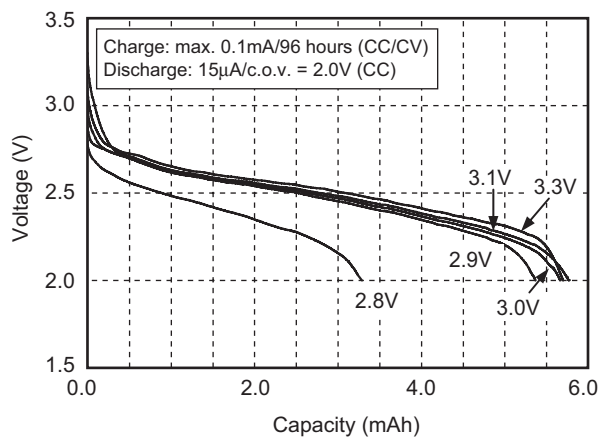

MS920SE

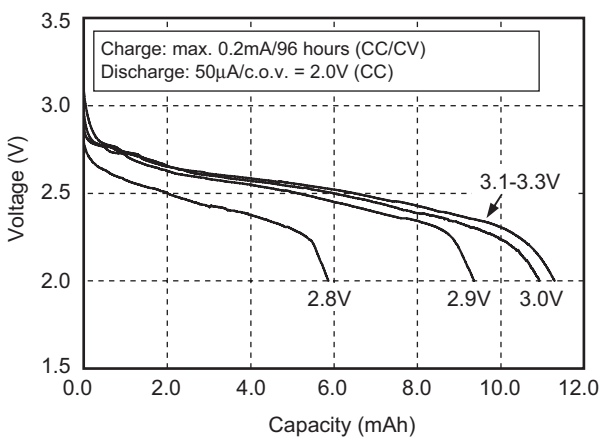

* c.o.v. : Cut off Voltage

CHARACTERISTICS

MS614SE

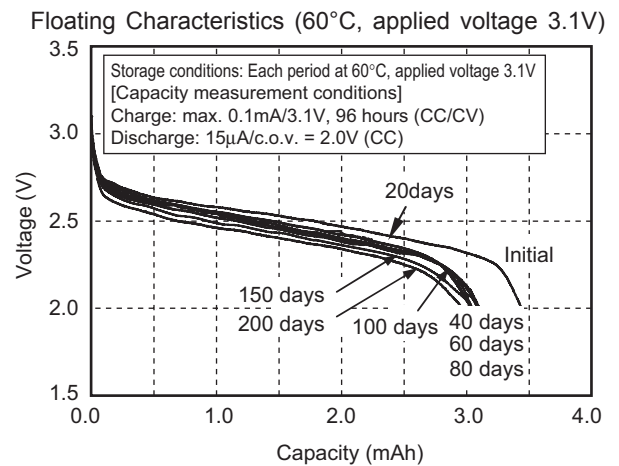
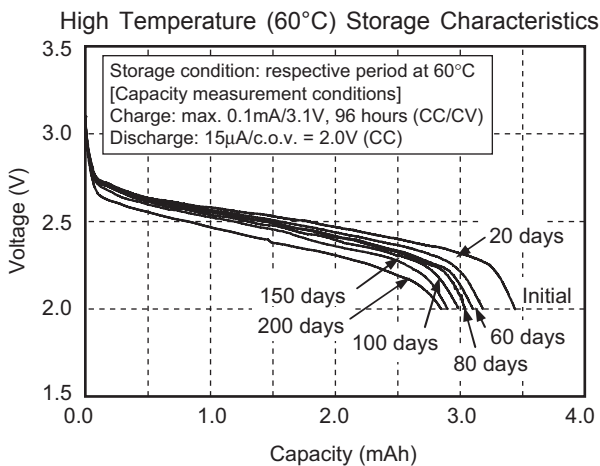
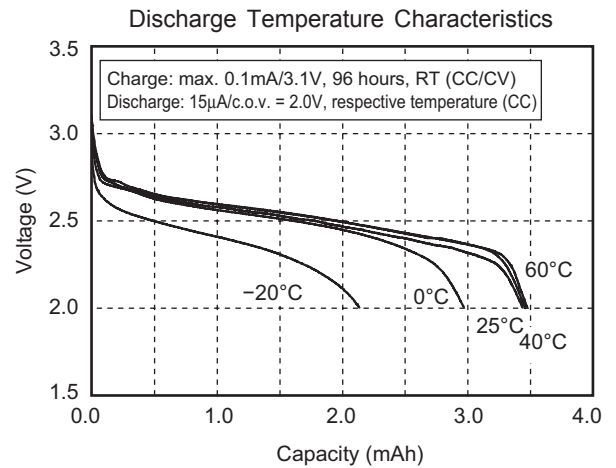
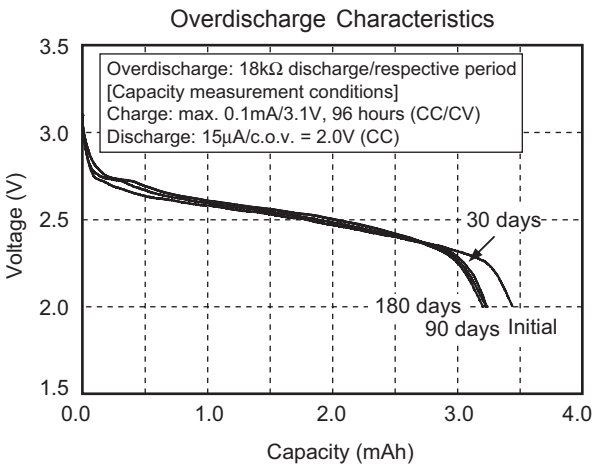
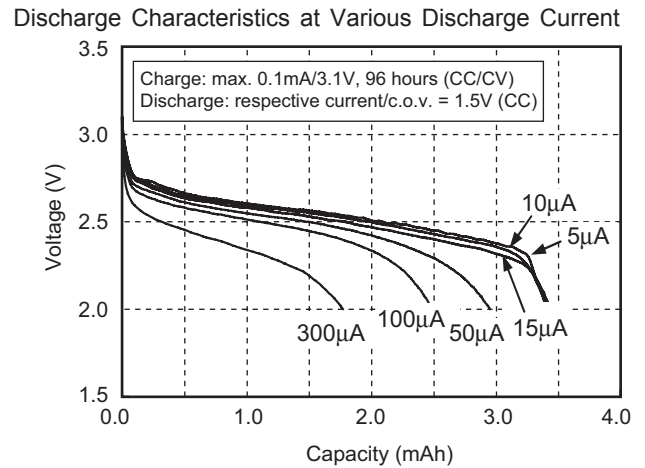
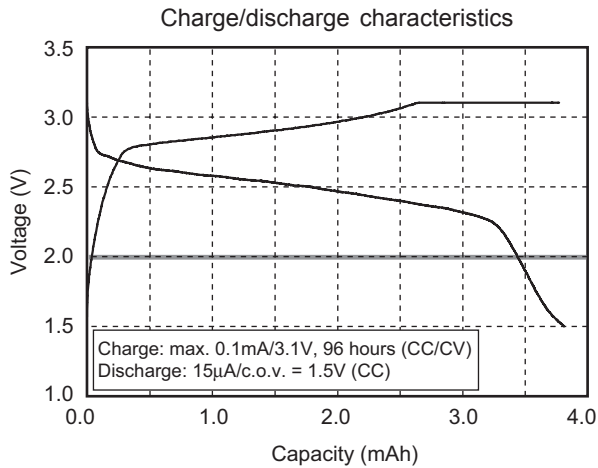

DIMENSIONS OF STANDARD TERMINALS OF MS LITHIUM RECHARGEABLE BATTERIES

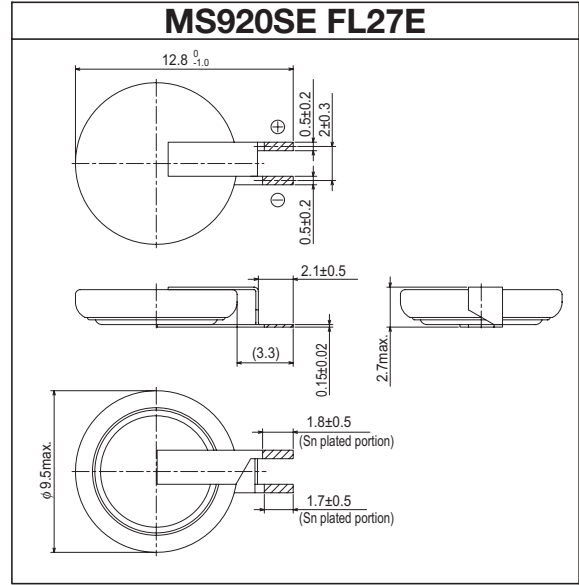
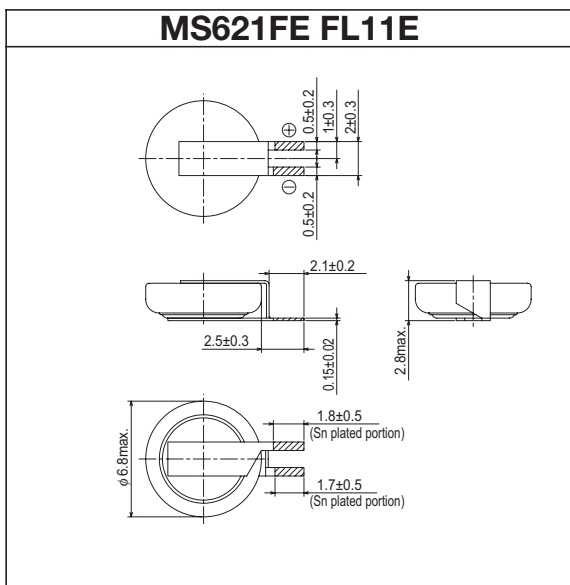
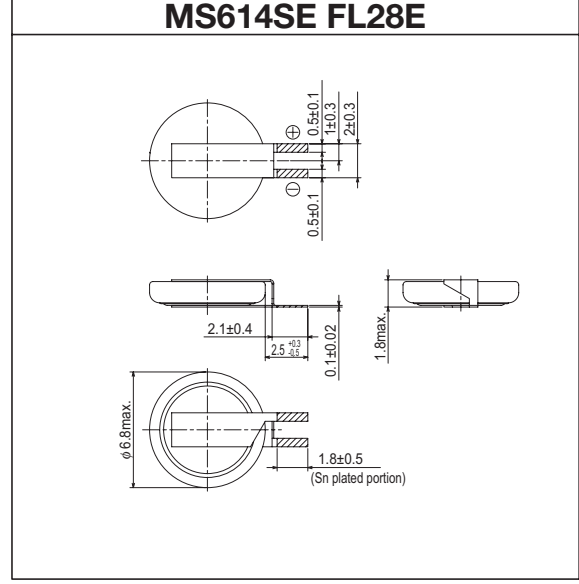
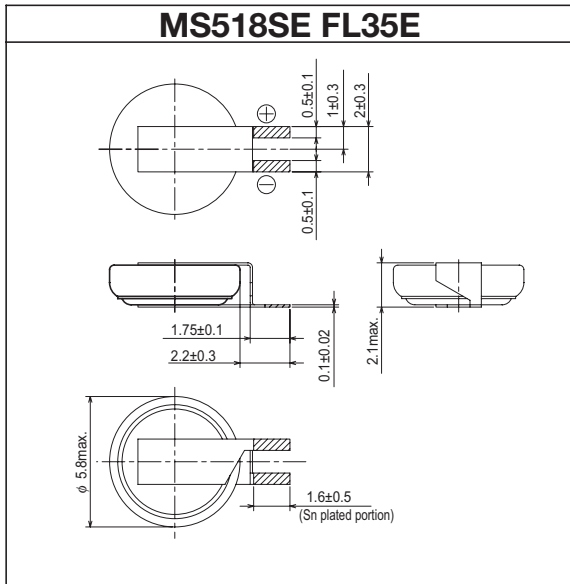
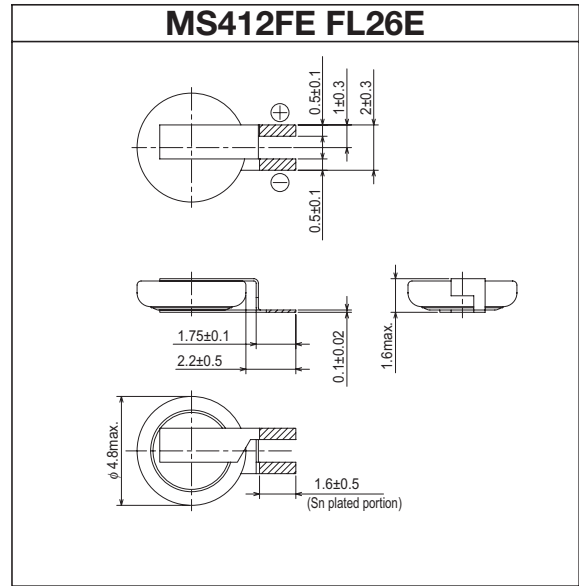
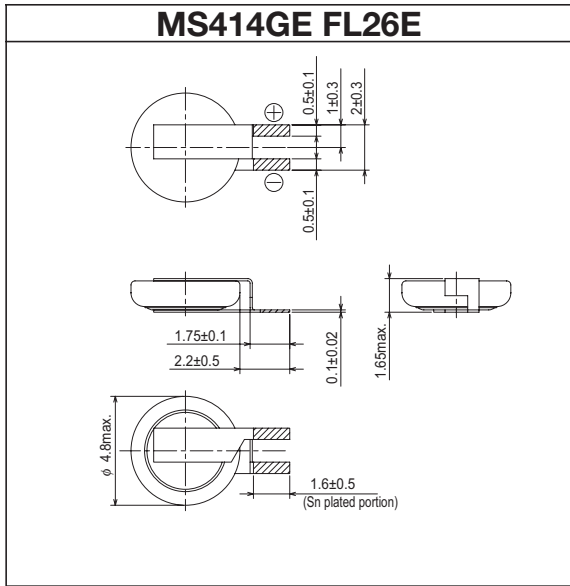

- Units: mm
- The hatched parts are tin plated (Sn: 100%).

TS920E / TS621E (Under Development)

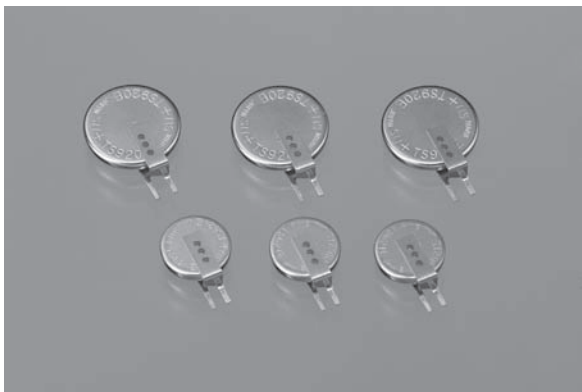

FEATURES

- Low-voltage rechargeable
- High capacity
- Long cycle life: at least 1000 cycles (20% D.O.D.)
- RoHS Compliant

TS lithium rechargeable batteries are high capacity 1.5V type non-reflowable rechargeable batteries that provide sufficient discharge capacity with a charge voltage of less than 2.0V.

SPECIFICATIONS

Type	Nominal Voltage (V)	Charge Voltage ^{*3} (V)	Nominal Capacity (Voltage Range V) (mAh)	Internal Impedance ^{*1} (Ω)	Standard Charge/Discharge Current (mA)	Cycle Life ^{*2} (Time)	Diameter (mm)	Height (mm)	Weight (g)
TS920E	1.5	1.6 to 3.0	5.5 (2.3 to 1.0)	20	0.05	1000 (20% D.O.D.) 100 (100% D.O.D.) ^{*4}	9.5	2.0	0.46
TS621E (Under development)	1.5	1.6 to 3.0					6.8	2.1	

*1. Value measured using an AC (Alternating Current) method in the fully charged state.

*2. Counts of charge and discharge repetition that maintains about 50% of the minimum guaranteed capacity

*3. A constant voltage charge is recommended, but due to a limit in the charge current, it is necessary to insert a resistor to regulate the charge current.

Please contact us for further details.

If a constant current charge is required, please contact us for more information.

*4. D.O.D. : Depth of Discharge

TS Lithium Rechargeable Batteries are not reflowable. Please mount them on PCB by hand soldering.

CHARACTERISTICS

Charge/discharge characteristics

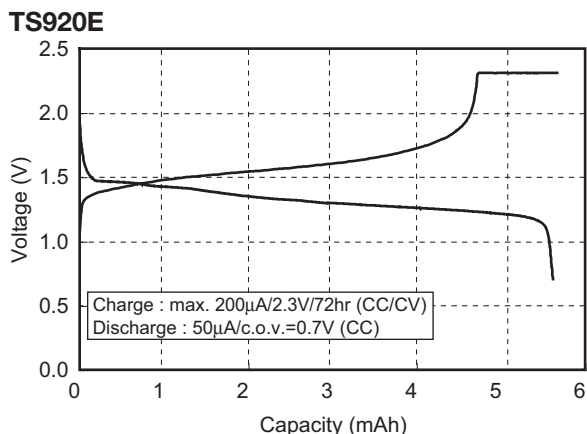

* c.o.v. : Cut off Voltage

CHARACTERISTICS

TS920E

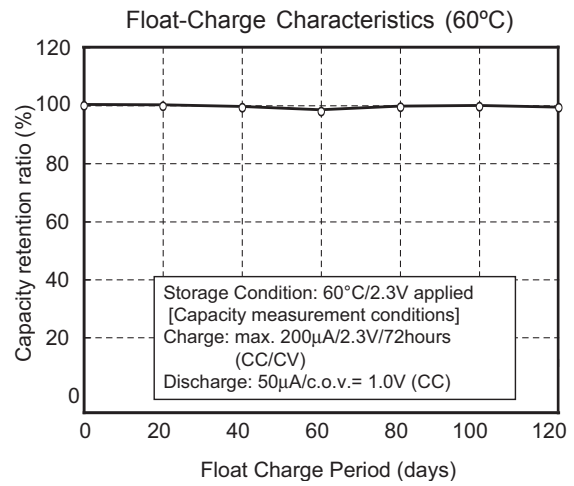
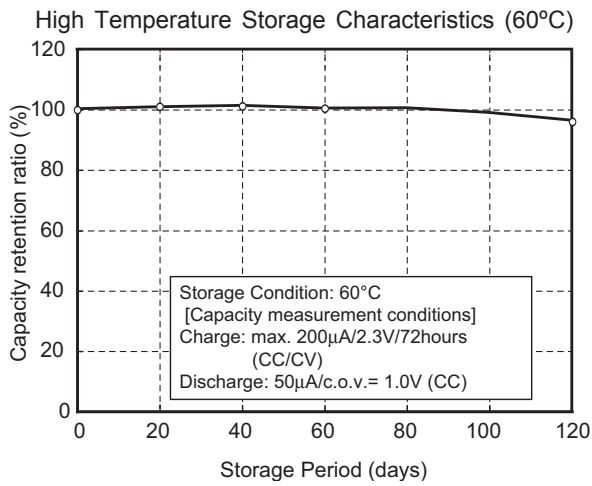
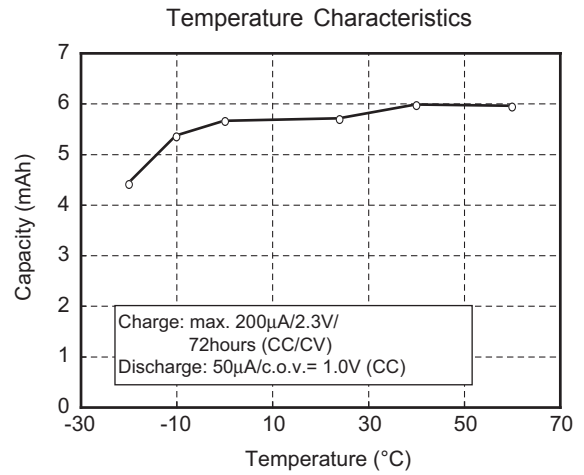
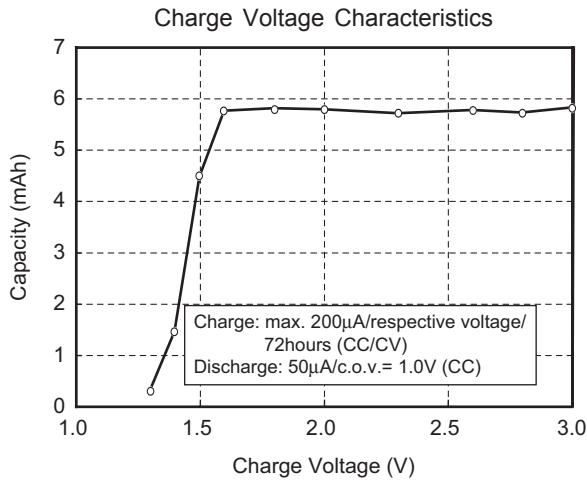

STANDARD TERMINALS

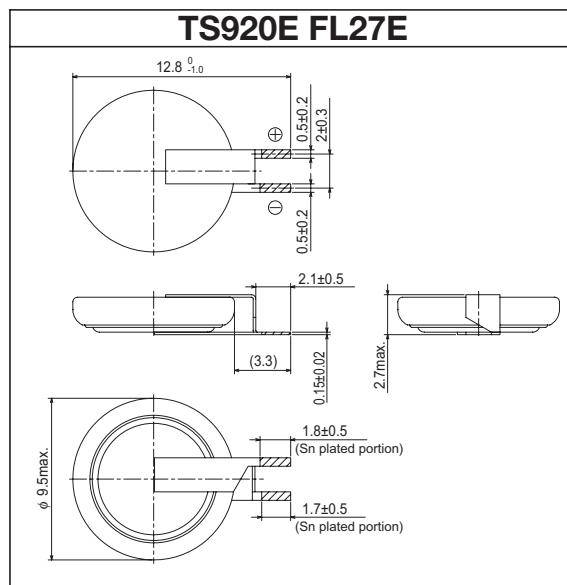

- Units: mm
- The hatched parts are tin plated (Sn: 100%).

CPH3225A

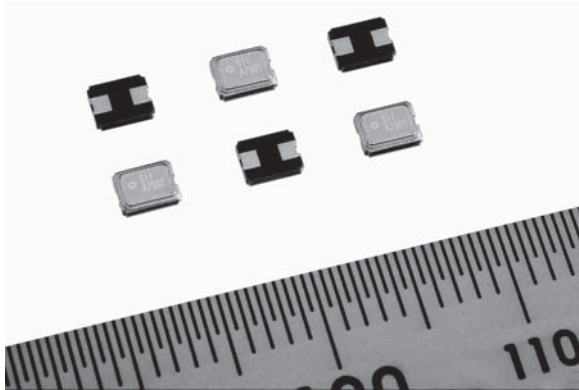

CPH3225A is thinnest and smallest chip-type electric double layer capacitor.

The unique ceramic packaging with superior air-tightness is used. As the result, it offers leakage resistance and humidity resistance. Also, by optimizing its materials, a 1 minute rapid charge stores approximately 85% of full capacity.

Its heat-resistant design allows for Pb-free reflowable SMT board attachment.

FEATURES

- Small and thin size
- Excellent leakage resistance and humidity resistance
- Pb-free reflowable:
 - Superior heat resistance (260°C peak) allows reflow soldering by Pb-free solder
- Long cycle Life:
 - At least 10,000 times of charge/discharge
- Simple Charging circuit (constant voltage charging)
- Wide operating temperature range:
 - Operating temperature range: -20°C to +60°C
 - For use the battery at a temperature out of the above temperature range, please consult us.
- RoHS Compliant

APPLICATIONS

Backup Power for various devices.

Super small size power supply.

Smartphone, Tablet, Cellphone, Personal computer, IC card, Game machine, Handy terminal, Video camera, various kinds of small appliance, etc.

SPECIFICATIONS

Type	Maximum Use Voltage (V)	Nominal Capacity (Voltage Range) Capacitance	Internal Impedance* <Nominal> (Ω)	Size(L × W × H) (mm)	Weight (g)
CPH3225A	3.3	4.6μAh (3.3V-1.8V) 0.011F	160	3.2 × 2.5 × 0.9	0.025

*. Value measured using AC (Alternating Current) method at the discharged state.

<APPLICATION NOTES>

• Prohibition ripple charging

A ripple (high frequency fluctuation of voltage) in the charge voltage extremely lowers the capacitor performance. Be sure to charge capacitors with a stable voltage.

• Charge voltage

The age deterioration of the capacitor depends on the charge voltage. The age deterioration is accelerated as charge voltage goes higher.

• Usage environment

Aging degradation of the capacitor varies depending on the usage environment (temperature and humidity). Contact us for further details.

CHARACTERISTICS

Charge/discharge characteristics

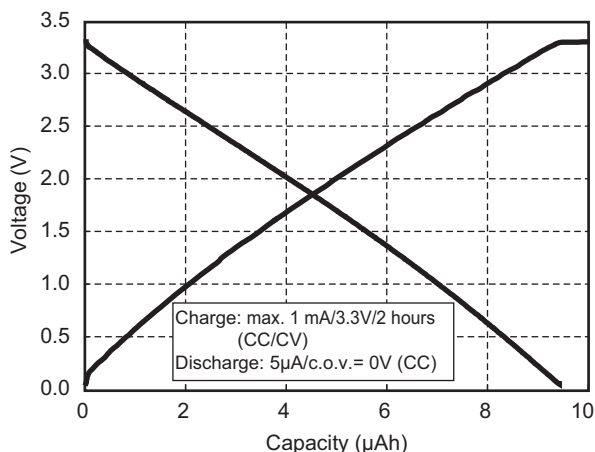

* c.o.v. : Cut off Voltage

CHARACTERISTICS

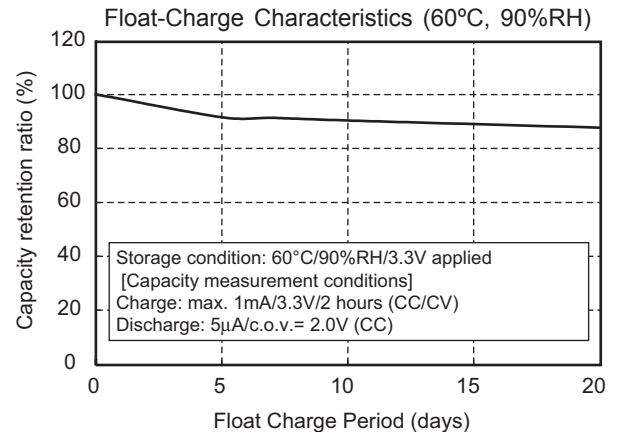
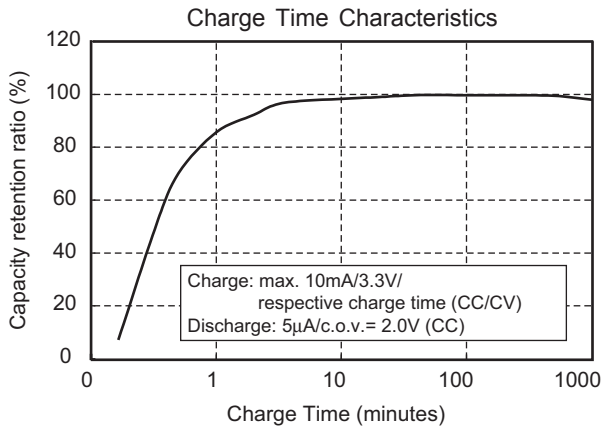

REFLOW SOLDERING CONDITIONS

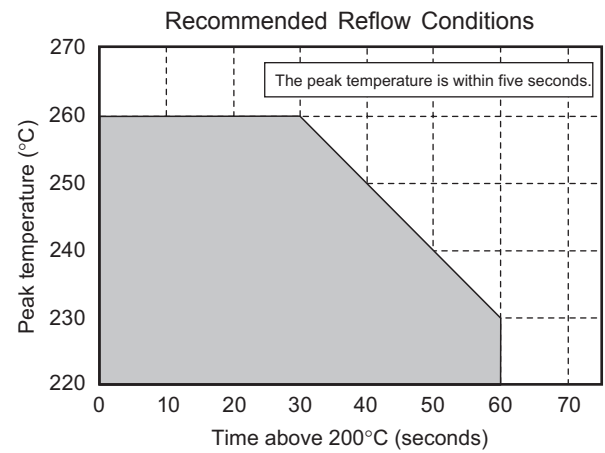
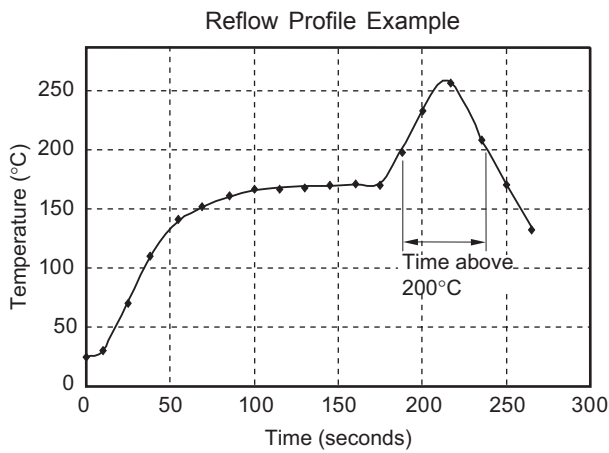

The times of repeated reflow soldering must be two times or less.
The Temperature must be measured at top of the cell.

DIMENSIONS

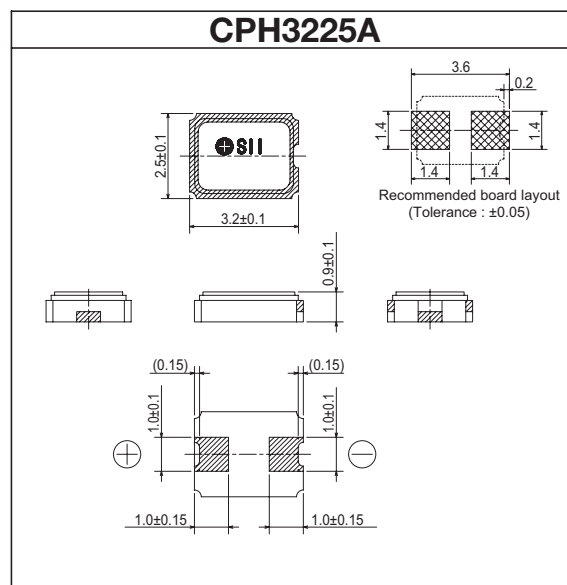

- Units: mm

XH311HG/XH311HU/XH414HG

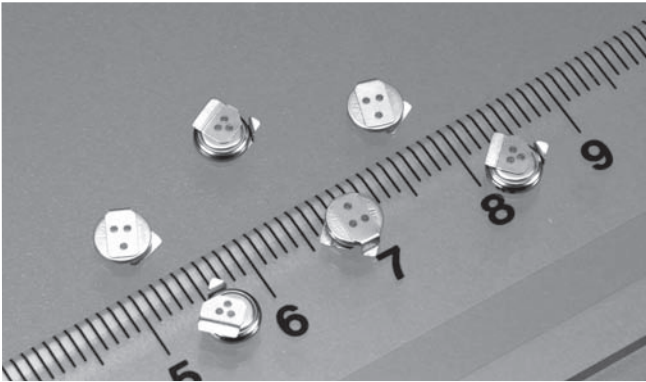

The XH series capacitor has a better discharge characteristic above 3V. It is an environmentally friendly product that is reflow mounted by Pb-free soldering. It features high capacity, and long-term reliability, as well as a wide operating voltage range. It is thus suitable for backup power supply of clock and memory functions on mobile and information devices.

FEATURES

- Pb-free reflowable:
Superior heat resistance (260°C peak) allows reflow soldering by Pb-free solder
- Wide operating voltage range from 0V to 3.3V
- High capacity: 0.08F with “414” size
- Long Cycle Life:
At least 10,000 times of charge/discharge
- Simple charging circuit (constant voltage charging)
- Wide operating temperature range:
Operating temperature range: -20°C to +60°C
For using the battery at a temperature out of the above temperature range, please consult us.
- RoHS Compliant

APPLICATIONS

Backup power supply for memory and clock functions of smartphone, tablet, cellphone, PHS, cordless phone, digital still camera, game machine, and printer, etc.

SPECIFICATIONS

Type	Electrical Specifications (Normal Temperature) ^{*1}			Size		Weight (g)
	Maximum Use Voltage (V)	Capacitance (F)	Internal Impedance ^{*2} (Ω)	Diameter (mm)	Height (mm)	
XH311HG	3.3	0.02	300	3.8	1.1	0.04
XH311HU	3.3	0.035	150	3.8	1.1	0.04
XH414HG	3.3	0.08	100	4.8	1.4	0.06

*1. Normal temperature: 23°C ± 3°C. Electrical characteristics and aging degradation of the products depend on temperature.

*2. Value measured using AC (Alternating Current) method at the discharged state.

<APPLICATION NOTES>

• Prohibition ripple charging

A ripple (high frequency fluctuation of voltage) in the charge voltage extremely lowers the capacitor performance. Be sure to charge capacitors with a stable voltage.

• Charge voltage

The age deterioration of the capacitor depends on the charge voltage. The age deterioration is accelerated as charge voltage goes higher.

• Usage environment

Aging degradation of the capacitor varies depending on the usage environment (temperature and humidity). Contact us for further details.

CHARACTERISTICS

Charge/discharge characteristics

XH311HG

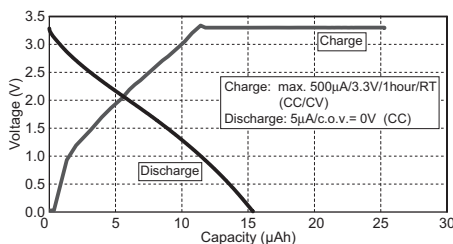

XH311HU

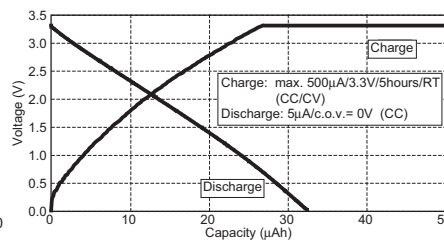

XH414HG

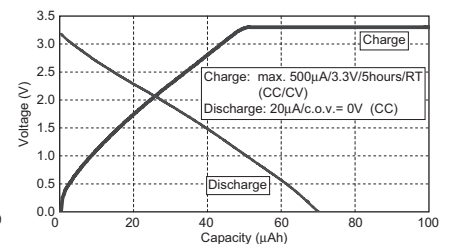

*c.o.v....Cut off Voltage

CHARACTERISTICS

XH414HG

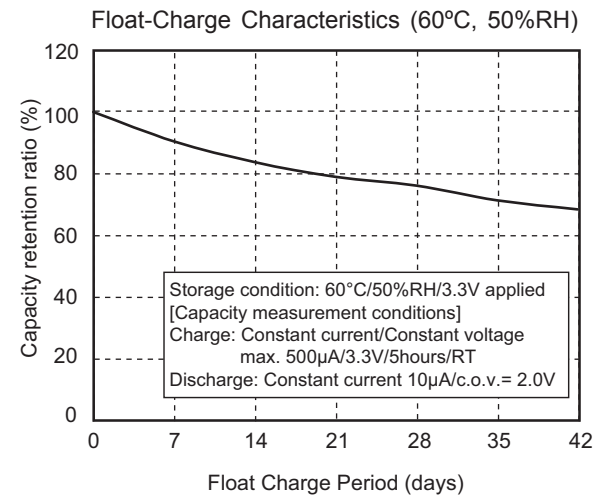
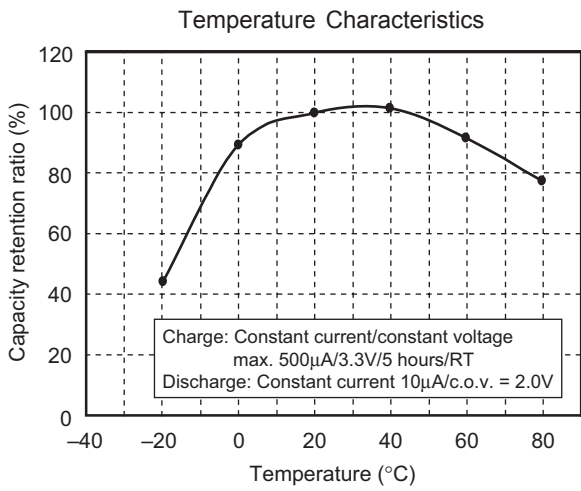
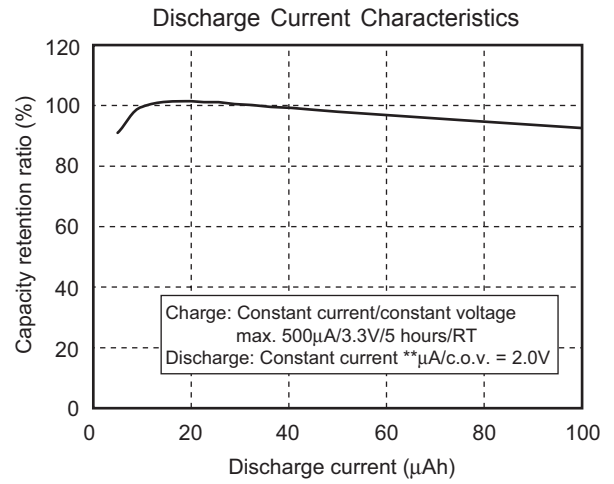
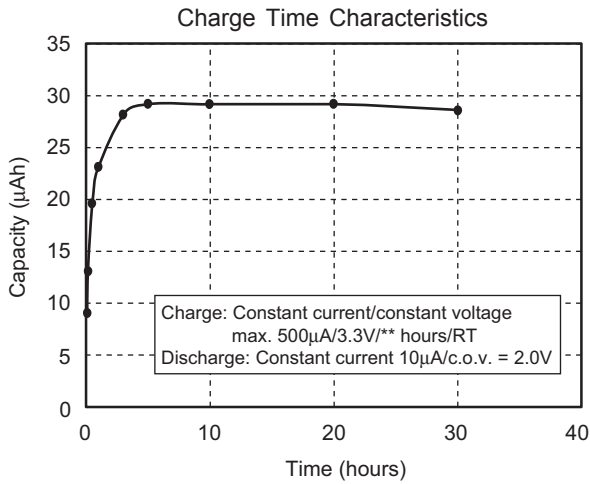

REFLOW SOLDERING CONDITIONS

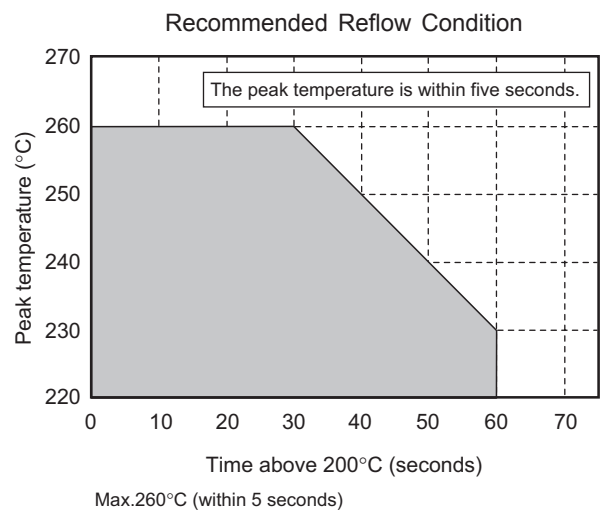
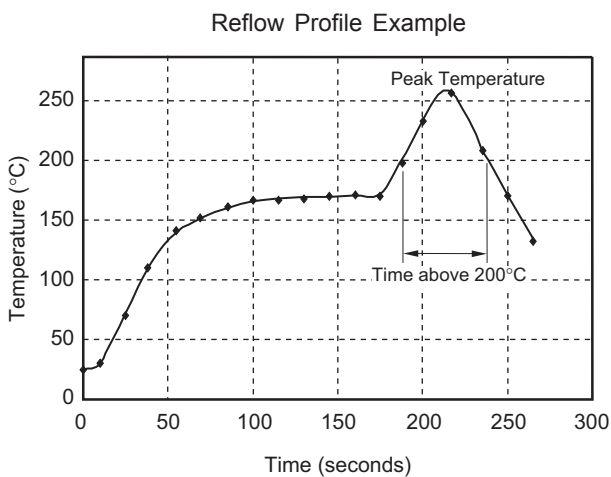

The times of repeated reflow soldering must be two times or less.
The Temperature must be measured at top of the cell.

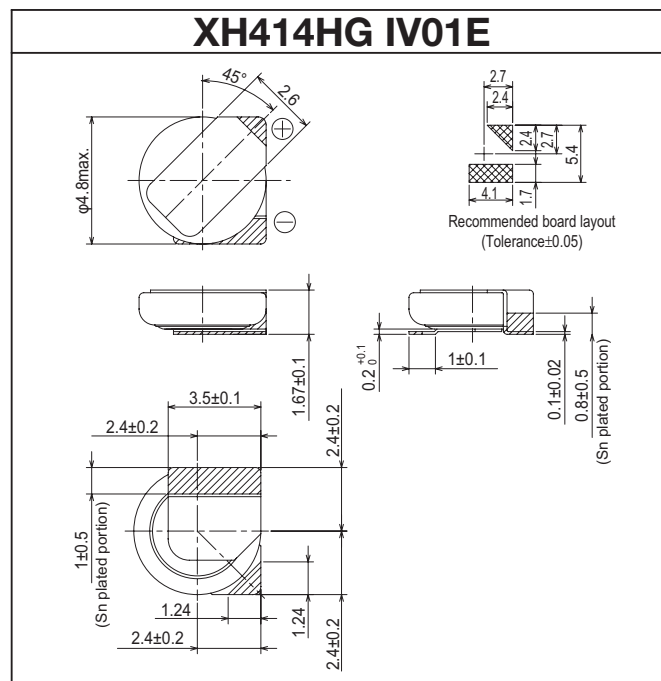
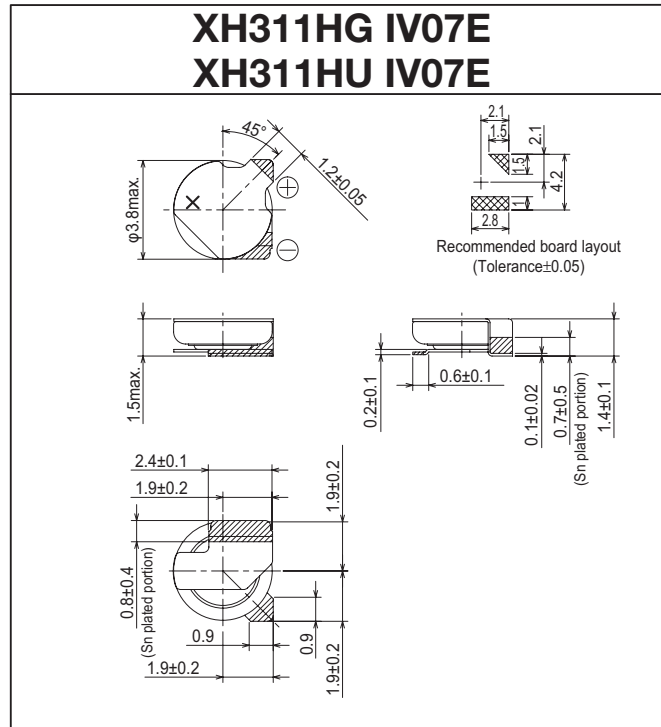

- Units: mm
- The hatched parts are tin plated (Sn: 100%).

Microbattery and Capacitor Selection Check Sheet

CHECK SHEET

If you are considering the purchase of one or more of our microbatteries or capacitors, please complete this check sheet and send it to us. We will let you know which products will be optimum for you to use.

Fax Sheet

Micro-Energy Division Sales Sec. +81-43-211-8034 Battery Sales Person

1. Your company name

2. Which application do you use?

3. Your expected backup period

hour / day / month

4. Your requested delivery date

mm / yy

5. Operation voltage of the device for backup

V to V

6. Consumption current at backup time

mA • μ A

7. Setting value of charging voltage

V

8. Presence of reverse current protection diode

Yes • No

9. Vf characteristics of the reverse current protection diode (at 10 μ A)

V

10. Resistance value of charging protection resistance

Ω

11. Limit of charging time

12. Required cycle life

times

13. Other requests

14. Expected life (e.g., xx years or backup for xx hours)

15. Ambient temperature and humidity

Your contact information

Name

Section

Phone

Fax

E-mail

Environmental Activities at Micro-Energy Division

Environment & Quality Policy

Seiko Instruments Inc., Micro-Energy Division is located in Ayashi, a city with beautiful nature, in Miyagi Prefecture. Our aim is to provide customer satisfaction and harmony with the environment through all our products, from Micro battery to other electronic products, and sales activities.

1. We adhere firmly to laws, regulations and customers' specified requirements.
2. We aim to prevent pollution, to reduce CO₂, and to conserve biodiversity.
3. We set goals, take actions, conduct regular reviews, and improve the system and performance continuously.
4. We contribute to the society by supporting green procurement, developing green products, and promoting green life activity.
5. We adhere to regulations and recommendations regarding Chemical substance content in our products and will promote reduction and replacement.
6. We vigorously educate ourselves and try to engage voluntarily in green life activity.

Based on the above policy, the following six environmental approaches are now being implemented throughout Micro-Energy Division.

1. Enrich the line up of Eco-Products

- We introduced the SII Green Product Label System which is equivalent to the ISO 14021 Type II environmental label. At the end of FY2006, 100% of our products are certified as SII Green Products. In addition, 36 products are certified as SII "High Grade" Green Products.

2. Reduction of Greenhouse Gas

- We practice various CO₂ reduction measures like using Eco-machinery. Since 1997, we have successfully reduced a total of 50,300 tons of CO₂. We believe our efforts contribute to the prevention of global warming.

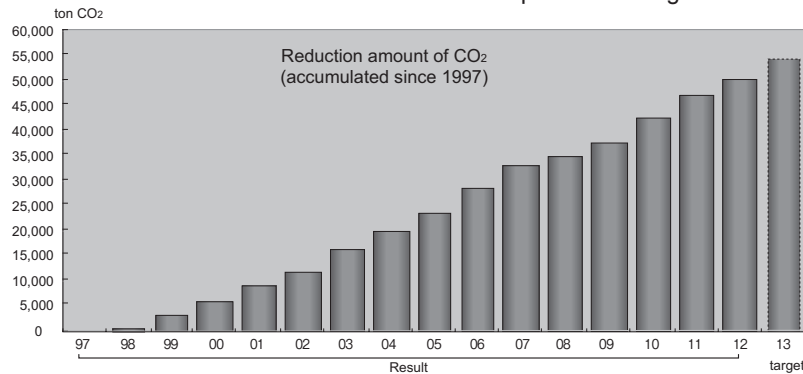

3. 3R Promotion Activity

- We have promoted the "reduce and reuse" activities and also promoted recycling at the end of the production process. With these activities, we achieved "Zero-emission" in 2004. We have reduced the non-recyclable wastes to less than 1 ton - less than 1% of our 1997 results.

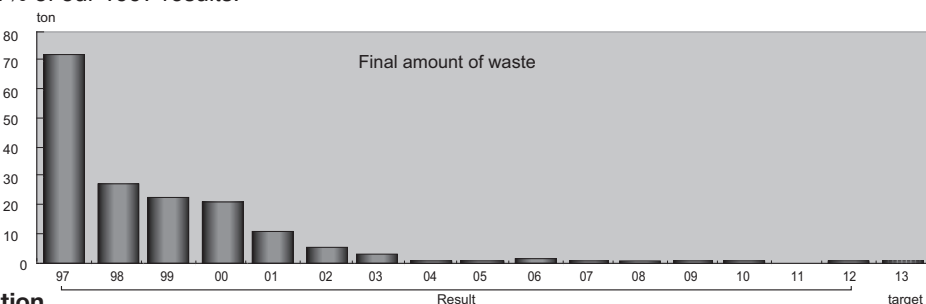

4. Biodiversity Conservation

- We endeavor to deepen our understanding on the relevancy between biodiversity and our business activities, and to contribute to the conservation of biodiversity by participating local community activities.

5. Green Purchasing

- We adhere to a green purchasing campaign through the purchase of ingredients, manufacturing materials, and other necessary products, whenever appropriate.

6. Green Life

- With the participation of all of Micro-Energy Division members, we deploy a clean-up and beautification campaign in all areas surrounding our factory twice a year. In addition, we participate in the clean up activity at Hirose River once a year.

7. Conflict Minerals

- Recognizing the international importance of conflict minerals issue, we prohibit the use of such minerals.

Precautions for Your Safety

Micro-Energy Division Lithium rechargeable batteries (MS, TS) contain flammable organic solvents. For your safety, please follow the following precautions.

⚠ WARNING!

- **Do not charge by higher current or higher voltage than specified.**
Doing so may generate gas inside the battery, resulting swelling, fire, heat generation or bursting.
- **Do not heat, disassemble nor dispose of in fire**
Doing so damages the insulation materials and may cause fire, heat generation, leakage or bursting.
- **Do not solder directly to the battery**
If soldering is performed directly to the battery, the battery is heated up, consequently causing leakage, explosion or fire due to overheating from internal short-circuit.
- **Do not short.**
If the (+) and (-) come into contact with metal materials, short-circuit occurs. As a result, fire, heat generation, leakage or bursting may occur.
- **Keep batteries out of children's reach.**
It is dangerous that children swallow the battery.
When you design mechanical hardware around the battery, please fix the battery firmly in order to prevent children from removing it.
When you store the batteries, please keep the batteries out of children's reach.
If a battery is swallowed, consult a physician immediately.
- **Do not reverse placement of (+) and (-)**
If the (+) and (-) side of the battery is reverse inserted, it may cause a short-circuit or over discharge of the battery on some equipment and it may induce overheating, explosion or fire.

- **Do not weld terminals to the battery**
The heat by welding may cause fire, heat generation, leakage or bursting.
We weld standard terminals under strictly controlled conditions.
If you need to weld terminals to the battery, please consult us in advance.
- **Do not discharge by force**
If the battery is discharged by direct connection to an external power supply etc., voltage of the battery will decline lower than 0 volts (electrical reversal) and will cause the battery case to expand, overheat, leak, explode or burn.
- **In case of leakage or a strange smell, keep away from fire to prevent ignition of any leaked electrolyte.**
- **In case of disposal, insulate between (+) and (-) of battery by an insulating material.**
Jumbling batteries or with other metal materials cause short-circuit. As a result, fire, heat generation, leakage or bursting may occur.

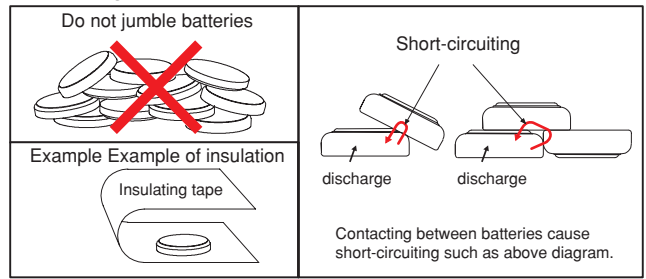

⚠ CAUTION!

- **If leaked liquid gets in the eyes, wash them with clean water and consult a physician immediately.**
- **Do not use new and used batteries together. Do not use different types of batteries together.**
It may cause fire, heat generation, leakage or bursting.
- **If you connect two or more batteries in series or parallel, please consult us in advance.**
It may cause bursting or fire due to unbalanced load or voltage.
- **Do not use nor leave the batteries in direct sunlight nor in high-temperature areas.**
It may cause fire, heat generation, leakage or bursting.
- **Do not apply strong pressure to the batteries nor handle roughly.**
It may cause fire, heat generation, leakage or bursting.
- **Avoid contact with water.**
It may cause heat generation.
- **Keep batteries away from direct sunlight, high temperature and humidity.**
It may cause heat generation or performance deterioration.

For prevention of performance deterioration of battery

- **Pay attention to mat or sheet for ESD**
Battery with tabs or battery on PCB may short-circuit on the mat for ESD. As a result the voltage of the cell is reduced.
- **Pay attention to soldering by tips**
Do not touch the battery by solder chips, when soldering another components after equipping battery.
Keep any high temperature process away from battery.
- **Pay attention to material of jig for pick and place**
Use non-conductive material of jig for pick and place of batteries, for short-circuit protect. If short-circuit of battery occurs, the voltage of battery drops down quickly but raises gradually.
- **Pay attention to washing and drying**
Some detergent or high temperature drying may cause deteriorate of battery. If you need to wash batteries, consult us.

International Transportation and Disposal

International Air/Marine/Ground Transportation

Regarding the transport of Lithium battery, organizations like IATA, ICAO, IMO, DOT have determined transport regulations, based on the United Nations Regulations.

The SII Lithium rechargeable batteries can be transported being not subject to the provisions of dangerous goods, if they meet the following requirements.

- (a) **<Caution Label>** Lithium battery handling label (IATA Dangerous Goods Regulations Figure 7.4.1) must be put on each package.
- (b) **<Not Restricted Declaration>** Each shipment must be accompanied with a document indicating that the packages contain Lithium batteries, that the packages must be handled with care, and that special procedures should be followed in the event the package is damaged, and a telephone number for additional information.

(c) **<Weight Limit>** Except in the case of packed with equipment, package may not exceed 2.5 kg gross mass.

(d) **<Strong Packaging>** Batteries are separated so as to prevent short-circuit and are packed in strong packaging.

(e) **<Package Drop Test>** Each packages is capable of withstanding a 1.2m drop test in any orientation without damage to batteries contained.

For further information, please consult with us.

Disposal

Recent environment protection concerns have increased globally and waste and recycling are regulated in the world. The current regulations differ in each country, state and local municipality. Please consult local regulations and authorities for recommended disposal of batteries. If you are in question of application or safety of our batteries, please consult your local authorities.

Precautions for Your Safety

Micro-Energy Division capacitors (XH, CPH, CPX) contain flammable organic solvents. For your safety, please follow the following precautions.

WARNING!

- **Do not charge by higher current or higher voltage than specified.**

Doing so may generate gas inside the capacitor, resulting in swelling, fire, heat generation or bursting.

- **Do not reverse placement of (+) and (-)**

All capacitors have polarity. If the (+) and (-) side of the capacitor is reverse inserted, it may cause short-circuit or over discharge of the capacitor on some equipment and it may induce overheating, explosion or fire.

- **Do not solder directly to the capacitor (for XH only)**

If soldering is performed directly to the capacitor, the capacitor will over heat and, consequently cause leakage, explosion or fire due to overheating from internal short-circuit.

- **Keep capacitors out of children's reach.**

It is dangerous that children swallow the capacitor.

When you design mechanical hardware around the capacitor, please fix the capacitor firmly in order to prevent children from removing it.

When you store the capacitors, please keep the capacitors out of children's reach. If a capacitor is swallowed, consult a physician immediately.

- **Do not heat, disassemble nor dispose of in fire**

Doing so damages the insulation materials and may cause fire, heat generation, leakage or bursting.

- **Do not discharge by force**

If the capacitor is discharged by direct connection to an external power supply etc., voltage of the capacitor will decline lower than 0 volts (electrical reversal) and will cause the capacitor case to expand, overheat, leak, explode or burn.

- **In case of leakage or a strange smell, keep away from fire to prevent ignition of any leaked electrolyte.**

CAUTION!

- **If leaked liquid gets in the eyes, wash them with clean water and consult a physician immediately.**

- **Do not use nor leave the capacitors in direct sunlight nor in high-temperature areas.**

It may cause fire, heat generation, leakage or bursting.

- **Do not make the capacitor airtight by sealing it with adhesive agent or coating agent.**

It may cause short-circuit because of generated and accumulated electrolyte gas.

- **Do not use new and used capacitors together. Do not use different types of capacitors together.**

It may cause fire, heat generation, leakage or bursting.

- **If you connect two or more capacitors in series or parallel, please consult us in advance.**

It may cause bursting or fire due to unbalanced load or voltage.

- **Keep capacitors away from direct sunlight, high temperature and humidity.**

It may cause heat generation or performance deterioration.

All data, dimensions, characteristics and values shown in this catalogue are for reference only. Please contact your local Seiko Instruments Representative for current detailed specifications.

IMPORTANT

1. The information herein is subject to change without notice.
2. Neither reproduction, duplication nor unauthorized use of this catalog in whole or part is allowed without the prior written approval of Seiko Instruments Inc.
3. The colors of the products reproduced herein ("Products") may be different from the actual colors. Check colors on actual products before using the Products.
4. Circuits and respective application methods described herein are for reference only. Seiko Instruments Inc. shall not be liable for any damages or losses resulting from any claim by third parties that any Products or application methods described herein infringe any right intellectual property right. All intellectual prop-

erty rights with respect to the Products belong exclusively to Seiko Instruments Inc.

Seiko Instruments Inc. does not grant users of the Products any right or license to the Products hereunder.

5. When Products include Strategic Products (or Services) stipulated in the Foreign Exchange and Trade Control Law, they shall not be exported without permission of governmental authorities.
6. The Products are designed for consumer equipment and cannot be used as part of any device or equipment which influences the human body or requires a significantly high reliability, such as physical exercise equipment, medical equipment, disaster prevention equipment, gas related equipment, vehicles, aircraft and equipment mounted on vehicles.

SII Electronic Components for Any Requirement !

Super-small,
low current consumption

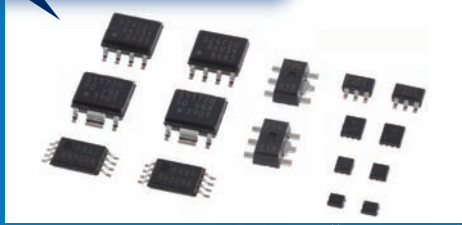

CMOS IC

ICs for various power supplies
Memory ICs (E²PROMs)
Sensors (temperature, magnetism, etc.)
Mini-analog
Real-time clocks

Best suited for
microprocessors



Quartz Crystal

Compact SMD tuning-fork quartz crystal unit
Quartz crystal unit for clocks
Quartz crystal unit for radio-controlled clocks

Compact

Energy saving

High accuracy

Low-voltage operation

High reliability

Maximum power
in a small body!



Micro Battery

Coin-type lithium rechargeable batteries
Capacitors(Coin-type, Chip-type)
Mercury-free silver oxide batteries

Small, precision
machining and
reflowable



DIANET Rare Earth Magnet

Samarium-cobalt (SmCo) magnets
Miniature precision springs
Metal diaphragms
etc.

Made by SII's unique
precision machining technology



SPRON Superior performance Co-Ni Alloy Product

Ideal for various applications !

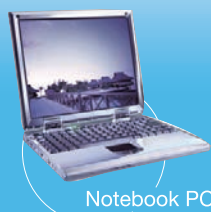



008

Micro-Energy Division who manufactures the products described in this catalog holds the ISO 9001 quality management system certificate, and the ISO 14001 environmental management systems certificate.



www.sii-me.com

Seiko Instruments Inc.

Micro-Energy Division

1-8, Nakase, Mihamaku, Chiba-shi, Chiba 261-8507, Japan
Telephone: +81-43-211-1735 Facsimile: +81-43-211-8034

Asia

Seiko Instruments (H.K.) Ltd.

4-5/F, Wyler Centre 2, 200 Tai Lin Pai Rd.,
Kwai Chung, N.T., Kowloon, Hong Kong
Telephone: +852-2494-5111
Facsimile: +852-2480-5479
Email: sales@sih.com.hk
<http://www.sih.com.hk>

Seiko Instruments Taiwan Inc.

12F, No.101, Sec.2, Nanking E. Rd.,
Taipei 104, Taiwan, R.O.C.
Telephone: +886-2-2563-5001
Facsimile: +886-2-2563-5580
Email: public@sii.co.jp
<http://www.sii.com.tw>

Seiko Instruments (Shanghai) Inc.

Room 2701-2703, 27th Floor,
Shanghai Plaza,
138 Mid Huaihai Rd.,
Shanghai 200021, China
Telephone: +86-21-6375-6611
Facsimile: +86-21-6375-6727

Seiko Instruments Korea Inc.

#507, 508, Korea City Air Terminal Bldg.,
159-6, Samsung-dong, Gangnam-gu,
Seoul, 135-728 Korea
Telephone: +82-2-565-8006
Facsimile: +82-2-565-8306
<http://www.sii.co.kr>

Europe

Seiko Instruments GmbH

Siemensstrasse 9
D-63263 Neu Isenburg, Germany
Telephone: +49-6102-297-0
Facsimile: +49-6102-297-50100
Email: info@seiko-instruments.de
<http://www.seiko-instruments.de>

North/Central/South America

Seiko Instruments U.S.A., Inc.

21221 S. Western Ave., Suite 250,
Torrance, CA 90501, U.S.A.
Telephone: +1-310-517-7802
Facsimile: +1-310-517-7792
Email: info@seikoinstruments.com
<http://www.sii-me.com>

Contact us

(Specifications are subject to change without notice.)

Released in September 2013



Mouser Electronics

Authorized Distributor

Click to View Pricing, Inventory, Delivery & Lifecycle Information:

[Seiko Instruments:](#)

[XH311HG-IV07E](#)