

Micron M25P40 Serial Flash Embedded Memory

M25P40VMB6Txx

M25P40VMC6Gx; M25P40VMC6Txx

M25P40VMN3Px; M25P40VMN3Txx

M25P40VMN6Pxx; M25P40VMN6Txxx

M25P40VMP6Gx; M25P40VMP6Txx

M25P40VMS6Gx; M25P40VMS6Tx

M25P40VMW6Gx; M25P40VMW6Txx

Features

- SPI bus compatible serial interface
- 4Mb Flash memory
- 75 MHz clock frequency (maximum)
- 2.3V to 3.6V single supply voltage
- Page program (up to 256 bytes) in 0.8ms (TYP)
- Erase capability
 - Sector erase: 512Kb in 0.6 s (TYP)
 - Bulk erase: 4Mb in 4.5 s (TYP)
- Write protection
 - Hardware write protection: protected area size defined by non-volatile bits BP0, BP1, BP2
- Deep power down: 1µA (TYP)
- Electronic signature
 - JEDEC standard 2-byte signature (2013h)
 - Unique ID code (UID) with 16-byte read-only space, available upon request
 - RES command, one-byte signature (12h) for backward compatibility
- More than 100,000 write cycles per sector
- Automotive grade parts available
- Packages (RoHS compliant)
 - SO8N (MN) 150mils
 - SO8W (MW) 208mils
 - DFN8 (MS) MLP8, 6mm x 5mm
 - VFDFPN8 (MP) MLP8 6mm x 5mm
 - UFDFPN8 (MC) MLP8 4mm x 3mm
 - UFDFPN8 (MB) MLP8 2mm x 3mm



Contents

Functional Description	6
Signal Descriptions	8
SPI Modes	9
Operating Features	11
Page Programming	11
Sector Erase, Bulk Erase	11
Polling during a Write, Program, or Erase Cycle	11
Active Power, Standby Power, and Deep Power-Down	11
Status Register	12
Data Protection by Protocol	12
Software Data Protection	12
Hardware Data Protection	12
Hold Condition	13
Configuration and Memory Map	14
Memory Configuration and Block Diagram	14
Memory Map – 4Mb Density	15
Command Set Overview	16
WRITE ENABLE	18
WRITE DISABLE	19
READ IDENTIFICATION	20
READ STATUS REGISTER	21
WIP Bit	21
WEL Bit	21
BP2, BP1, BP0 Bits	22
SRWD Bit	22
WRITE STATUS REGISTER	23
READ DATA BYTES	25
READ DATA BYTES at HIGHER SPEED	26
PAGE PROGRAM	27
SECTOR ERASE	28
BULK ERASE	29
DEEP POWER-DOWN	30
RELEASE from DEEP POWER-DOWN	31
READ ELECTRONIC SIGNATURE	32
Power-Up/Down and Supply Line Decoupling	33
Power-Up Timing and Write Inhibit Voltage Specifications	35
Maximum Ratings and Operating Conditions	36
Electrical Characteristics	37
AC Characteristics	39
Package Information	47
Device Ordering Information	53
Standard Parts	53
Automotive Parts	54
Revision History	55
Rev. X – 04/12	55
Rev. W – 03/12	55
Rev. V – 02/12	55
Rev. U – 09/2011	55
Rev. 20.0 – 04/2010	55
Rev. 19.0 – 02/2010	55



Micron M25P40 Serial Flash Embedded Memory Features

Rev. 18.0 – 05/2009	55
Rev. 17.0 – 02/2009	55
Rev. 16.0 – 10/2008	56
Rev. 15.0 – 12/2007	56
Rev. 14.0 – 06/2007	56
Rev. 13.0 – 05/2007	56
Rev. 12.0 – 01/2007	56
Rev. 11.0 – 12/2006	56
Rev. 10.0 – 06/2006	57
Rev. 9.0 – 04/2006	57
Rev. 8.0 – 12/2005	57
Rev. 7.0 – 10/2005	57
Rev. 6.0 – 08/2005	57
Rev. 5.0 – 01/2005	57
Rev. 4.0 – 08/2004	57
Rev. 3.0 – 03/2004	58
Rev. 2.0 – 11/2003	58
Rev. 1.0 – 06/2003	58

List of Figures

Figure 1: Logic Diagram	6
Figure 2: Pin Connections: SO8, MLP8	7
Figure 3: SPI Modes Supported	9
Figure 4: Bus Master and Memory Devices on the SPI Bus	10
Figure 5: Hold Condition Activation	13
Figure 6: Block Diagram	14
Figure 7: WRITE ENABLE Command Sequence	18
Figure 8: WRITE DISABLE Command Sequence	19
Figure 9: READ IDENTIFICATION Command Sequence	20
Figure 10: READ STATUS REGISTER Command Sequence	21
Figure 11: Status Register Format	21
Figure 12: WRITE STATUS REGISTER Command Sequence	23
Figure 13: READ DATA BYTES Command Sequence	25
Figure 14: READ DATA BYTES at HIGHER SPEED Command Sequence	26
Figure 15: PAGE PROGRAM Command Sequence	27
Figure 16: SECTOR ERASE Command Sequence	28
Figure 17: BULK ERASE Command Sequence	29
Figure 18: DEEP POWER-DOWN Command Sequence	30
Figure 19: RELEASE from DEEP POWER-DOWN Command Sequence	31
Figure 20: READ ELECTRONIC SIGNATURE Command Sequence	32
Figure 21: Power-Up Timing	34
Figure 22: AC Measurement I/O Waveform	39
Figure 23: Serial Input Timing	45
Figure 24: Write Protect Setup and Hold during WRSR when SRWD=1 Timing	45
Figure 25: Hold Timing	46
Figure 26: Output Timing	46
Figure 27: SO8N 150mils Body Width	47
Figure 28: SO8W 208mils Body Width	48
Figure 29: DFN8 6mm x 5mm	49
Figure 30: VFDFPN8 (MLP8) 6mm x 5mm	50
Figure 31: UFDFPN8 (MLP8) 4mm x 3mm	51
Figure 32: UFDFPN8 (MLP8) 2mm x 3mm	52



List of Tables

Table 1: Signal Names	6
Table 2: Signal Descriptions	8
Table 3: Protected Area Sizes	12
Table 4: Sectors[7:0]	15
Table 5: Command Set Codes	17
Table 6: READ IDENTIFICATION Data Out Sequence	20
Table 7: Status Register Protection Modes	23
Table 8: Power-Up Timing and V_{WI} Threshold	35
Table 9: Absolute Maximum Ratings	36
Table 10: Operating Conditions	36
Table 11: Data Retention and Endurance	36
Table 12: DC Current Specifications (Device Grade 6)	37
Table 13: DC Voltage Specifications (Device Grade 6)	37
Table 14: DC Current Specifications (Device Grade 3)	37
Table 15: DC Voltage Specifications (Device Grade 3)	38
Table 16: Device Grade and AC Table Correlation	39
Table 17: AC Measurement Conditions	39
Table 18: Capacitance	39
Table 19: Instruction Times, Process Technology 110nm	40
Table 20: Instruction Times, Process Technology 150nm	40
Table 21: AC Specifications (25 MHz, Device Grade 3, $V_{CC}[\min]=2.7V$)	40
Table 22: AC Specifications (50 MHz, Device Grade 6, $V_{CC}[\min]=2.7V$)	41
Table 23: AC Specifications (40 MHz, Device Grade 6, $V_{CC}[\min]=2.3V$)	42
Table 24: AC Specifications (75MHz, Device Grade 3 and 6, $V_{CC}[\min]=2.7V$)	44
Table 25: Part Number Example	53
Table 26: Part Number Information Scheme	53
Table 27: Part Number Example	54
Table 28: Part Number Information Scheme	54

Functional Description

The M25P40 is an 4Mb (512Kb x 8) serial Flash memory device with advanced write protection mechanisms accessed by a high speed SPI-compatible bus. The device supports high-performance commands for clock frequency up to 75MHz.

The memory can be programmed 1 to 256 bytes at a time using the PAGE PROGRAM command. It is organized as 8 sectors, each containing 256 pages. Each page is 256 bytes wide.

The entire memory can be erased using the BULK ERASE command, or it can be erased one sector at a time using the SECTOR ERASE command.

This datasheet details the functionality of the M25P40 device based on either the 150nm process or on the current 110nm process. The most current device in the 110nm process has the following additional features and is completely backward compatible with the 150nm device:

- Maximum frequency (READ DATA BYTES at HIGHER SPEED operation) in the standard Vcc range 2.7V to 3.6V equals 75MHz
- Maximum frequency (READ DATA BYTES at HIGHER SPEED operation) in the extended Vcc range 2.3V to 2.7V equals 40MHz
- UID/CFD protection feature

Note: 75MHz operation is available only on the VCC range 2.7V to 3.6V and for 110nm process technology devices, identified by process identification digit 4 in the device marking and process letter B in the part number.

Figure 1: Logic Diagram

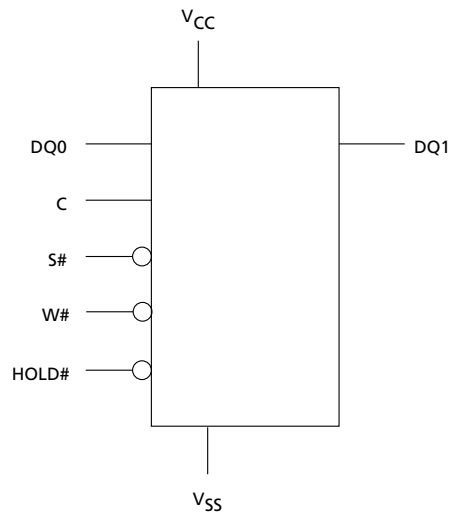

Table 1: Signal Names

Signal Name	Function	Direction
C	Serial clock	Input

Table 1: Signal Names (Continued)

Signal Name	Function	Direction
DQ0	Serial data input	Input
DQ1	Serial data output	Output
S#	Chip select	Input
W#	Write protect or enhanced program supply voltage	Input
HOLD#	Hold	Input
V _{CC}	Supply voltage	–
V _{SS}	Ground	–

Figure 2: Pin Connections: SO8, MLP8

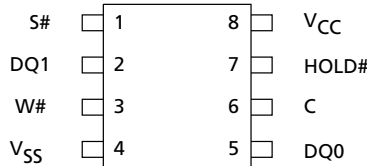

There is an exposed central pad on the underside of the MLP8 package that is pulled internally to V_{SS}, and must not be connected to any other voltage or signal line on the PCB. The Package Mechanical section provides information on package dimensions and how to identify pin 1.



Signal Descriptions

All signals types listed here may not be supported on this device. See Signal Assignments for information specific to this device.

Table 2: Signal Descriptions

Signal	Type	Description
DQ1	Output	Serial data: The DQ1 output signal is used to transfer data serially out of the device. Data is shifted out on the falling edge of the serial clock (C).
DQ0	Input	Serial data: The DQ0 input signal is used to transfer data serially into the device. It receives commands, addresses, and the data to be programmed. Values are latched on the rising edge of the serial clock (C).
C	Input	Clock: The C input signal provides the timing of the serial interface. Commands, addresses, or data present at serial data input (DQ0) are latched on the rising edge of the serial clock (C). Data on DQ1 changes after the falling edge of C.
S#	Input	Chip select: When the S# input signal is HIGH, the device is deselected and DQ1 is at HIGH impedance. Unless an internal PROGRAM, ERASE, or WRITE STATUS REGISTER cycle is in progress, the device will be in the standby power mode (not the deep power-down mode). Driving S# LOW enables the device, placing it in the active power mode. After power-up, a falling edge on S# is required prior to the start of any command.
HOLD#	Input	Hold: The HOLD# signal is used to pause any serial communications with the device without deselecting the device. During the hold condition, DQ1 is HIGH impedance. DQ0 and C are Don't care. To start the hold condition, the device must be selected, with S# driven LOW.
W#	Input	Write protect: The W# input signal is used to freeze the size of the area of memory that is protected against program or erase commands as specified by the values in BP2, BP1, and BP0 bits of the Status Register.
V _{CC}	Input	Device core power supply: Source voltage.
V _{SS}	Input	Ground: Reference for the VCC supply voltage..

SPI Modes

These devices can be driven by a microcontroller with its serial peripheral interface (SPI) running in either of the following two SPI modes:

- CPOL=0, CPHA=0
- CPOL=1, CPHA=1

For these two modes, input data is latched in on the rising edge of serial clock (C), and output data is available from the falling edge of C.

The difference between the two modes is the clock polarity when the bus master is in STANDBY mode and not transferring data:

- C remains at 0 for (CPOL=0, CPHA=0)
- C remains at 1 for (CPOL=1, CPHA=1)

Figure 3: SPI Modes Supported

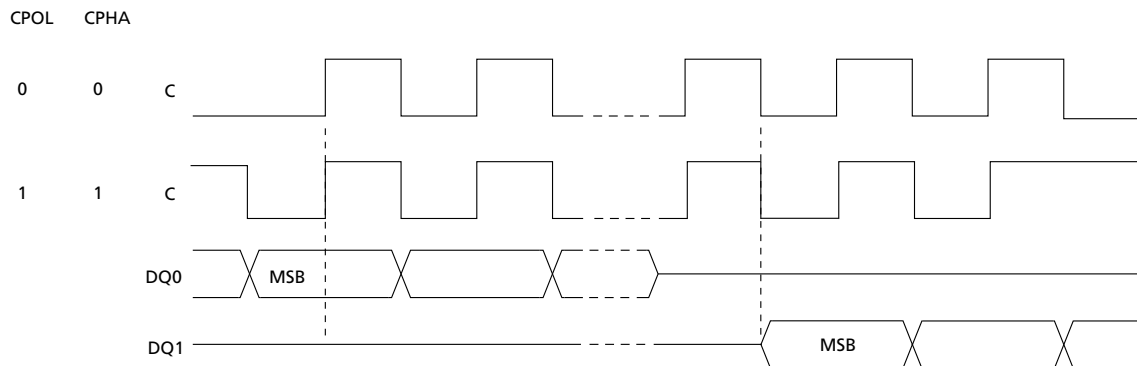

Because only one device is selected at a time, only one device drives the serial data output (DQ1) line at a time, while the other devices are HIGH-Z. An example of three devices connected to an MCU on an SPI bus is shown here.

Figure 4: Bus Master and Memory Devices on the SPI Bus

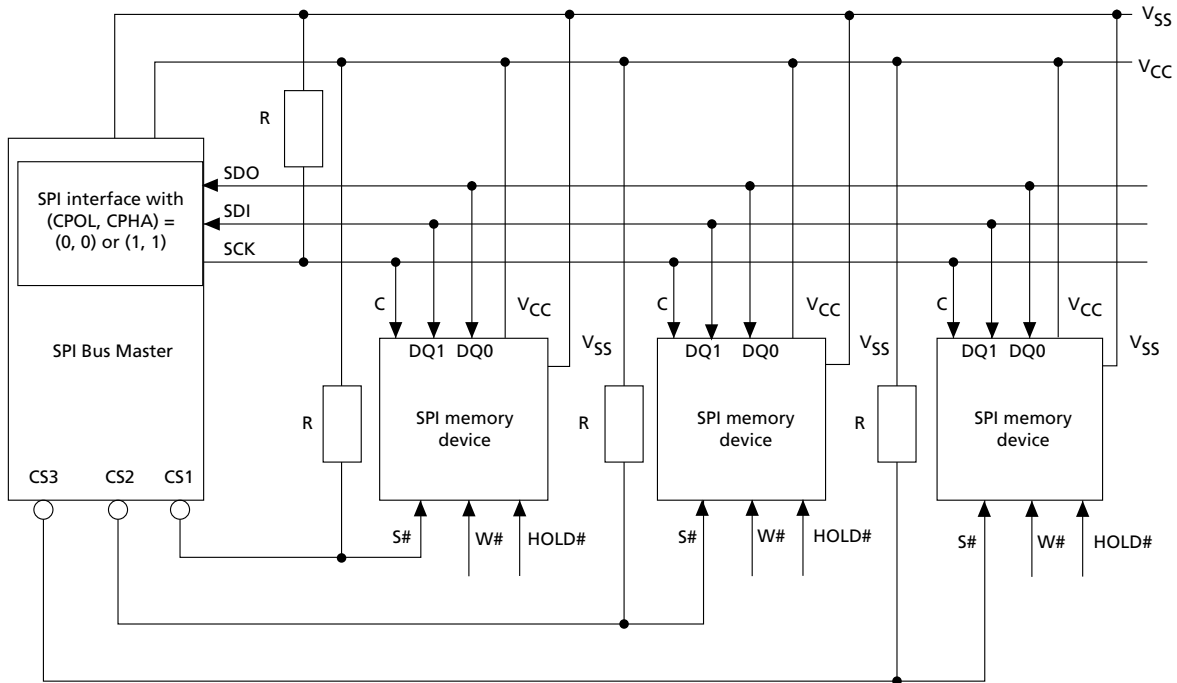

- Notes:
1. WRITE PROTECT (W#) and HOLD# should be driven HIGH or LOW as appropriate.
 2. Resistors (R) ensure that the memory device is not selected if the bus master leaves the S# line HIGH-Z.
 3. The bus master may enter a state where all I/O are HIGH-Z at the same time; for example, when the bus master is reset. Therefore, the C must be connected to an external pull-down resistor so that when all I/O are HIGH-Z, S# is pulled HIGH while C is pulled LOW. This ensures that S# and C do not go HIGH at the same time and that the t_{SHCH} requirement is met.
 4. The typical value of R is 100 k Ω , assuming that the time constant $R \times C_p$ (C_p = parasitic capacitance of the bus line) is shorter than the time during which the bus master leaves the SPI bus HIGH-Z.
 5. Example: Given that $C_p = 50$ pF ($R \times C_p = 5\mu s$), the application must ensure that the bus master never leaves the SPI bus HIGH-Z for a time period shorter than 5 μs .

Operating Features

Page Programming

To program one data byte, two commands are required: WRITE ENABLE, which is one byte, and a PAGE PROGRAM sequence, which is four bytes plus data. This is followed by the internal PROGRAM cycle of duration t_{PP} . To spread this overhead, the PAGE PROGRAM command allows up to 256 bytes to be programmed at a time (changing bits from 1 to 0), provided they lie in consecutive addresses on the same page of memory. To optimize timings, it is recommended to use the PAGE PROGRAM command to program all consecutive targeted bytes in a single sequence than to use several PAGE PROGRAM sequences with each containing only a few bytes.

Sector Erase, Bulk Erase

The PAGE PROGRAM command allows bits to be reset from 1 to 0. Before this can be applied, the bytes of memory need to have been erased to all 1s (FFh). This can be achieved a sector at a time using the SECTOR ERASE command, or throughout the entire memory using the BULK ERASE command. This starts an internal ERASE cycle of duration t_{SSE} , t_{SE} or t_{BE} . The ERASE command must be preceded by a WRITE ENABLE command.

Polling during a Write, Program, or Erase Cycle

An improvement in the time to complete the following commands can be achieved by not waiting for the worst case delay (t_W , t_{PP} , t_{SE} , or t_{BE}).

- WRITE STATUS REGISTER
- PROGRAM
- ERASE (SECTOR ERASE, BULK ERASE)

The write in progress (WIP) bit is provided in the status register so that the application program can monitor this bit in the status register, polling it to establish when the previous WRITE cycle, PROGRAM cycle, or ERASE cycle is complete.

Active Power, Standby Power, and Deep Power-Down

When chip select ($S\#$) is LOW, the device is selected, and in the ACTIVE POWER mode. When $S\#$ is HIGH, the device is deselected, but could remain in the ACTIVE POWER mode until all internal cycles have completed (PROGRAM, ERASE, WRITE STATUS REGISTER). The device then goes in to the STANDBY POWER mode. The device consumption drops to I_{CC1} .

The DEEP POWER-DOWN mode is entered when the DEEP POWER-DOWN command is executed. The device consumption drops further to I_{CC2} . The device remains in this mode until the RELEASE FROM DEEP POWER-DOWN command is executed. While in the DEEP POWER-DOWN mode, the device ignores all WRITE, PROGRAM, and ERASE commands. This provides an extra software protection mechanism when the device is not in active use, by protecting the device from inadvertent WRITE, PROGRAM, or ERASE operations. For further information, see DEEP POWER-DOWN (page 30).

Status Register

The status register contains a number of status and control bits that can be read or set (as appropriate) by specific commands. For a detailed description of the status register bits, see READ STATUS REGISTER (page 21).

Data Protection by Protocol

Non-volatile memory is used in environments that can include excessive noise. The following capabilities help protect data in these noisy environments.

Power on reset and an internal timer (t_{PUW}) can provide protection against inadvertent changes while the power supply is outside the operating specification.

WRITE, PROGRAM, and WRITE STATUS REGISTER commands are checked before they are accepted for execution to ensure they consist of a number of clock pulses that is a multiple of eight.

All commands that modify data must be preceded by a WRITE ENABLE command to set the write enable latch (WEL) bit.

In addition to the low power consumption feature, the DEEP POWER-DOWN mode offers extra software protection since all WRITE, PROGRAM, and ERASE commands are ignored when the device is in this mode.

Software Data Protection

Software data protection is achieved as follows:

Memory can be configured as read-only using the block protect bits (BP2, BP1, BP0) as shown in the Protected Area Sizes table.

Hardware Data Protection

Hardware data protection is implemented using the write protect signal applied on the W# pin. This freezes the status register in a read-only mode. In this mode, the block protect bits (BP2, BP1, BP0) and the status register write disable bit (SRWD) are protected.

Table 3: Protected Area Sizes

Status Register Content			Memory Content	
BP Bit 2	BP Bit 1	BP Bit 0	Protected Area	Unprotected Area
0	0	0	none	All sectors (sectors 0 to 7)
0	0	1	Upper 8th (sectors 7)	Lower 7/8ths (sectors 0 to 6)
0	1	0	Upper 4th (sectors 6 and 7)	Lower 3/4ths (sectors 0 to 5)
0	1	1	Upper half (sectors 4 to 7)	Lower half (sectors 0 to 3)
1	0	0	All sectors (sectors 0 to 7)	none
1	0	1	All sectors (sectors 0 to 7)	none
1	1	0	All sectors (sectors 0 to 7)	none
1	1	1	All sectors (sectors 0 to 7)	none

Note: 1. 0 0 0 = unprotected area (sectors): The device is ready to accept a BULK ERASE command only if all block protect bits (BP2, BP1, BP0) are 0.

Hold Condition

The HOLD# signal is used to pause any serial communications with the device without resetting the clocking sequence. However, taking this signal LOW does not terminate any WRITE STATUS REGISTER, PROGRAM, or ERASE cycle that is currently in progress.

To enter the hold condition, the device must be selected, with S# LOW. The hold condition starts on the falling edge of the HOLD# signal, if this coincides with serial clock (C) being LOW. The hold condition ends on the rising edge of the HOLD# signal, if this coincides with C being LOW. If the falling edge does not coincide with C being LOW, the hold condition starts after C next goes LOW. Similarly, if the rising edge does not coincide with C being LOW, the hold condition ends after C next goes LOW.

During the hold condition, the serial data output (DQ1) is HIGH impedance, and serial data input (DQ0) and C are Don't Care. Normally, the device is kept selected, with S# driven LOW for the whole duration of the hold condition. This ensures that the state of the internal logic remains unchanged from the moment of entering the hold condition. If S# goes HIGH while the device is in the hold condition, the internal logic of the device is reset. To restart communication with the device, it is necessary to drive HOLD# HIGH, and then to drive S# LOW. This prevents the device from going back to the hold condition.

Figure 5: Hold Condition Activation

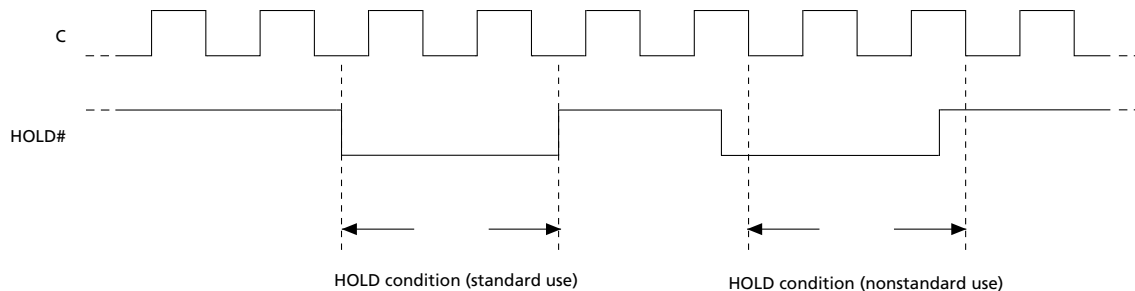

Configuration and Memory Map

Memory Configuration and Block Diagram

Each page of memory can be individually programmed; bits are programmed from 1 to 0. The device is sector or bulk-erasable, but not page-erasable; bits are erased from 0 to 1. The memory is configured as follows:

- 524,288 bytes (8 bits each)
- 8 sectors (512Kb, 65KB each)
- 2,048 pages (256 bytes each)

Figure 6: Block Diagram

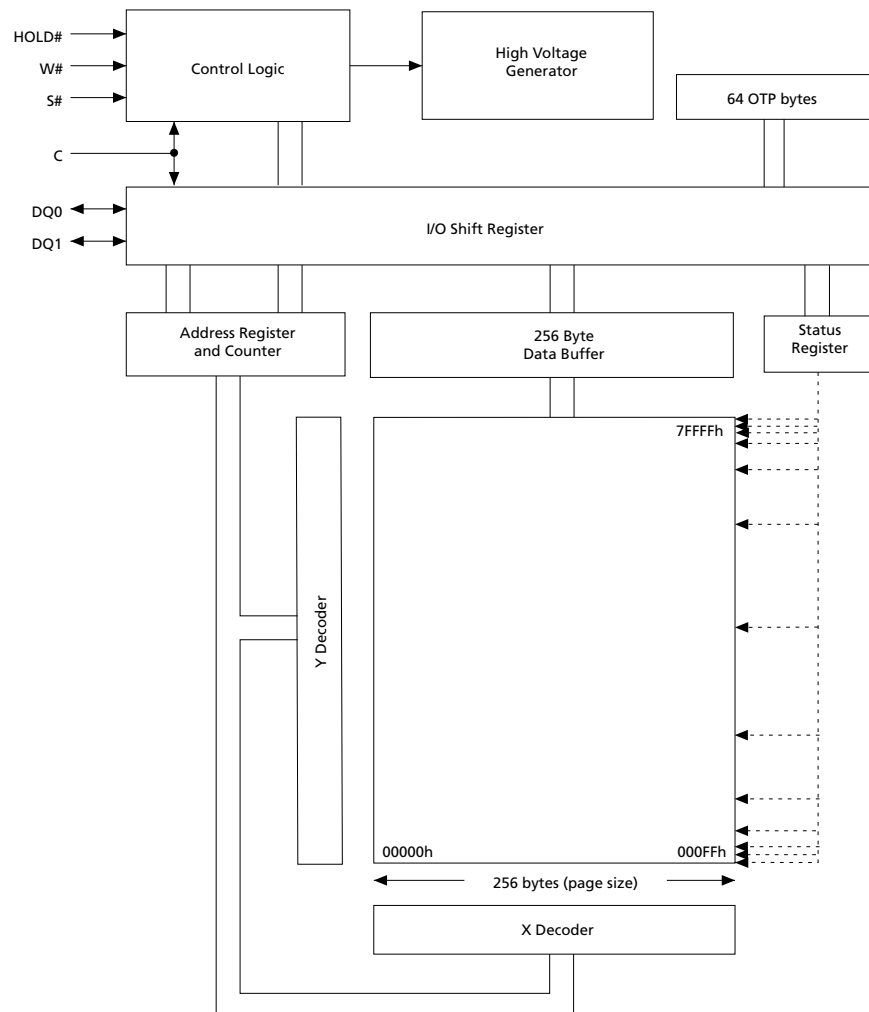



Memory Map – 4Mb Density

Table 4: Sectors[7:0]

Sector	Address Range	
	Start	End
7	0007 0000h	0007 FFFFh
6	0006 0000h	0006 FFFFh
5	0005 0000h	0005 FFFFh
4	0004 0000h	0004 FFFFh
3	0003 0000h	0003 FFFFh
2	0002 0000h	0002 FFFFh
1	0001 0000h	0001 FFFFh
0	0000 0000h	0000 FFFFh

Command Set Overview

All commands, addresses, and data are shifted in and out of the device, most significant bit first.

Serial data inputs DQ0 and DQ1 are sampled on the first rising edge of serial clock (C) after chip select (S#) is driven LOW. Then, the one-byte command code must be shifted in to the device, most significant bit first, on DQ0 and DQ1, each bit being latched on the rising edges of C.

Every command sequence starts with a one-byte command code. Depending on the command, this command code might be followed by address or data bytes, by address and data bytes, or by neither address or data bytes. For the following commands, the shifted-in command sequence is followed by a data-out sequence. S# can be driven HIGH after any bit of the data-out sequence is being shifted out.

- READ DATA BYTES (READ)
- READ DATA BYTES at HIGHER SPEED
- READ STATUS REGISTER
- READ IDENTIFICATION
- RELEASE from DEEP POWER-DOWN
- READ ELECTRONIC SIGNATURE

For the following commands, S# must be driven HIGH exactly at a byte boundary. That is, after an exact multiple of eight clock pulses following S# being driven LOW, S# must be driven HIGH. Otherwise, the command is rejected and not executed.

- PAGE PROGRAM
- SECTOR ERASE
- BULK ERASE
- WRITE STATUS REGISTER
- WRITE ENABLE
- WRITE DISABLE
- DEEP POWER-DOWN

All attempts to access the memory array are ignored during a WRITE STATUS REGISTER command cycle, a PROGRAM command cycle, or an ERASE command cycle. In addition, the internal cycle for each of these commands continues unaffected.



Table 5: Command Set Codes

Command Name	One-Byte Command Code		Bytes		
			Address	Dummy	Data
WRITE ENABLE	0000 0110	06h	0	0	0
WRITE DISABLE	0000 0100	04h	0	0	0
READ IDENTIFICATION	1001 1111	9Fh	0	0	1 to 20
	1001 1110	9Eh	0	0	1 to 3
READ STATUS REGISTER	0000 0101	05h	0	0	1 to ∞
WRITE STATUS REGISTER	0000 0001	01h	0	0	1
READ DATA BYTES	0000 0011	03h	3	0	1 to ∞
READ DATA BYTES at HIGHER SPEED	0000 1011	0Bh	3	1	1 to ∞
PAGE PROGRAM	0000 0010	02h	3	0	1 to 256
SECTOR ERASE	1101 1000	D8h	3	0	0
BULK ERASE	1100 0111	C7h	0	0	0
DEEP POWER-DOWN	1011 1001	B9h	0	0	0
RELEASE from DEEP POWER-DOWN	1010 1011	ABh	0	0	0
READ ELECTRONIC SIGNATURE and RELEASE from DEEP POWER-DOWN	1010 1011	ABh	0	3	1 to ∞

WRITE ENABLE

The WRITE ENABLE command sets the write enable latch (WEL) bit.

The WEL bit must be set before execution of every PROGRAM, ERASE, and WRITE command.

The WRITE ENABLE command is entered by driving chip select (S#) LOW, sending the command code, and then driving S# HIGH.

Figure 7: WRITE ENABLE Command Sequence

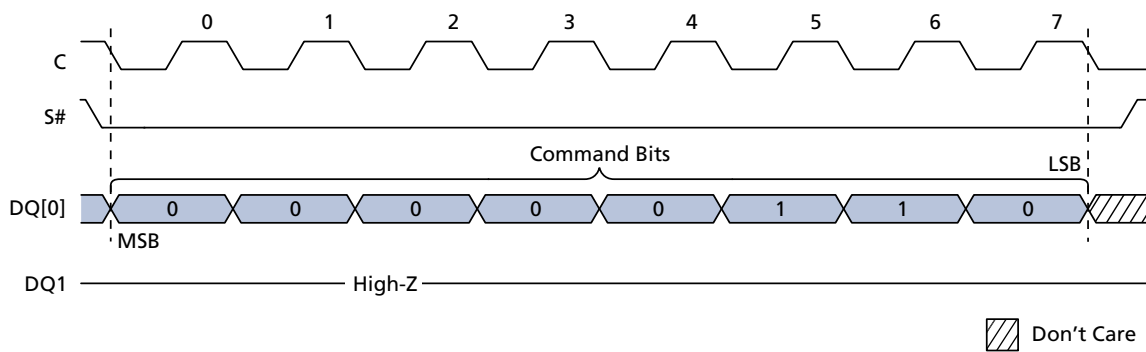

WRITE DISABLE

The WRITE DISABLE command resets the write enable latch (WEL) bit.

The WRITE DISABLE command is entered by driving chip select (S#) LOW, sending the command code, and then driving S# HIGH.

The WEL bit is reset under the following conditions:

- Power-up
- Completion of any ERASE operation
- Completion of any PROGRAM operation
- Completion of any WRITE REGISTER operation
- Completion of WRITE DISABLE operation

Figure 8: WRITE DISABLE Command Sequence

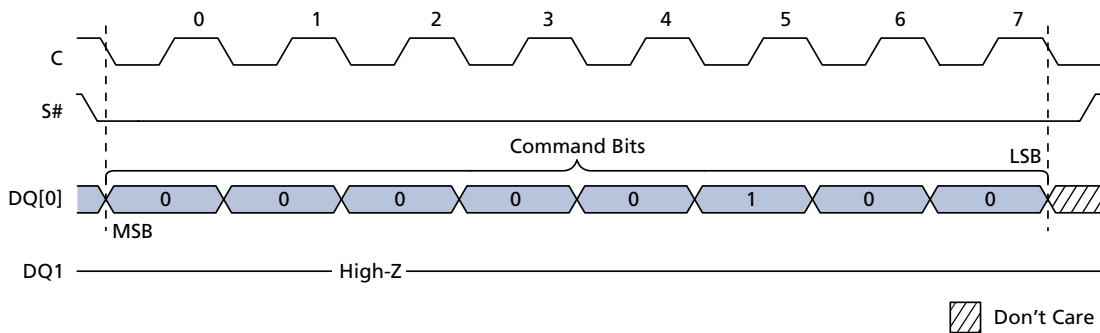

READ IDENTIFICATION

The READ IDENTIFICATION command reads the following device identification data:

- Manufacturer identification (1 byte): This is assigned by JEDEC.
- Device identification (2 bytes): This is assigned by device manufacturer; the first byte indicates memory type and the second byte indicates device memory capacity.
- A Unique ID code (UID) (17 bytes, 16 available upon customer request): The first byte contains length of data to follow; the remaining 16 bytes contain optional Customized Factory Data (CFD) content.

Table 6: READ IDENTIFICATION Data Out Sequence

Manufacturer Identification	Device Identification		UID	
	Memory Type	Memory Capacity	CFD Length	CFD Content
20h	20h	13h	10h	16 bytes

Note: 1. The CFD bytes are read-only and can be programmed with customer data upon demand. If customers do not make requests, the devices are shipped with all the CFD bytes programmed to zero. See on page for CFD programmed devices.

A READ IDENTIFICATION command is not decoded while an ERASE or PROGRAM cycle is in progress and has no effect on a cycle in progress. The READ IDENTIFICATION command must not be issued while the device is in DEEP POWER-DOWN mode.

The device is first selected by driving chip select (S#) LOW. Then the 8-bit command code is shifted in and content is shifted out on serial data output (DQ1) as follows: the 24-bit device identification that is stored in the memory, the 8-bit CFD length, followed by 16 bytes of CFD content. Each bit is shifted out during the falling edge of serial clock (C).

The READ IDENTIFICATION command is terminated by driving S# HIGH at any time during data output. When S# is driven HIGH, the device is put in the STANDBY POWER mode and waits to be selected so that it can receive, decode, and execute commands.

Figure 9: READ IDENTIFICATION Command Sequence

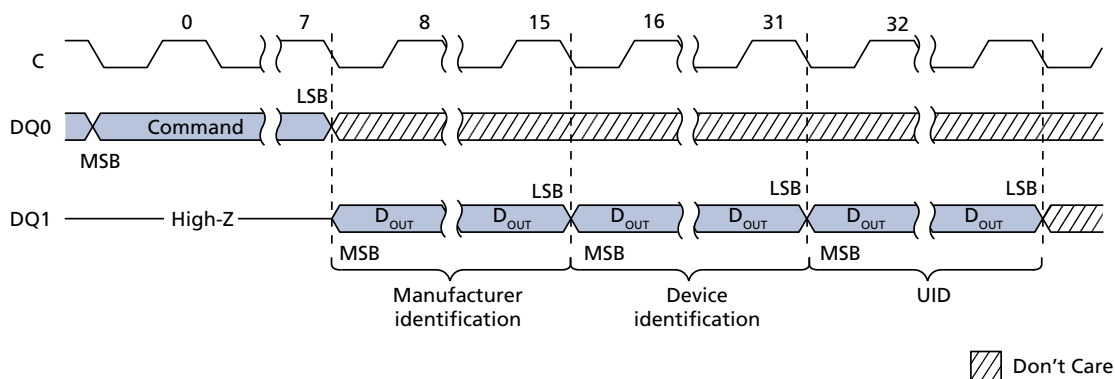

READ STATUS REGISTER

The READ STATUS REGISTER command allows the status register to be read. The status register may be read at any time, even while a PROGRAM, ERASE, or WRITE STATUS REGISTER cycle is in progress. When one of these cycles is in progress, it is recommended to check the write in progress (WIP) bit before sending a new command to the device. It is also possible to read the status register continuously.

Figure 10: READ STATUS REGISTER Command Sequence

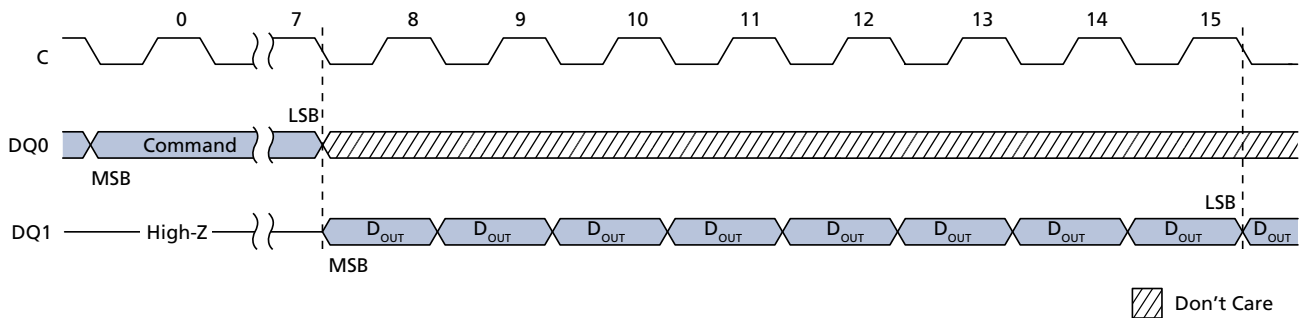
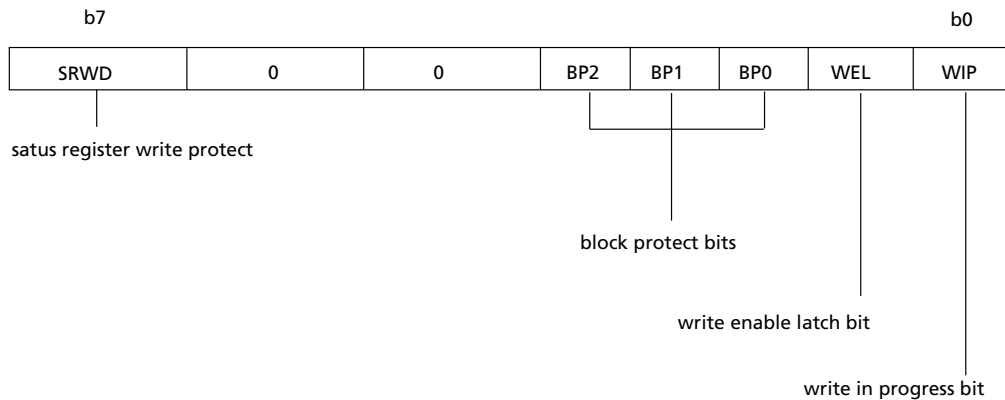

Figure 11: Status Register Format



WIP Bit

The WIP bit indicates whether the memory is busy with a WRITE STATUS REGISTER cycle, a PROGRAM cycle, or an ERASE cycle. When the WIP bit is set to 1, a cycle is in progress; when the WIP bit is set to 0, a cycle is not in progress.

WEL Bit

The write enable latch (WEL) bit indicates the status of the internal write enable latch. When the WEL bit is set to 1, the internal write enable latch is set; when the WEL bit is

set to 0, the internal write enable latch is reset and no WRITE STATUS REGISTER, PROGRAM, or ERASE command is accepted.

BP2, BP1, BP0 Bits

The block protect (BP2, BP1, BP0) bits are non-volatile. They define the size of the area to be software protected against PROGRAM and ERASE commands. The block protect bits are written with the WRITE STATUS REGISTER command.

When one or more of the block protect (BP2, BP1, BP0) bits is set to 1, the relevant memory area, as defined in the Protected Area Sizes table, becomes protected against PAGE PROGRAM and SECTOR ERASE commands. The block protect (BP2, BP1, BP0) bits can be written provided that the HARDWARE PROTECTED mode has not been set. The BULK ERASE command is executed only if all block protect (BP2, BP1, BP0) bits are 0.

SRWD Bit

The SRWD bit is operated in conjunction with the write protect ($W\#/V_{pp}$) signal. When the SRWD bit is set to 1 and $W\#/V_{pp}$ is driven LOW, the device is put in the hardware protected mode. In the hardware protected mode, the non-volatile bits of the status register (SRWD, BP2, BP1, BP0) become read-only bits and the WRITE STATUS REGISTER command is no longer accepted for execution.

WRITE STATUS REGISTER

The WRITE STATUS REGISTER command allows new values to be written to the status register. Before the WRITE STATUS REGISTER command can be accepted, a WRITE ENABLE command must have been executed previously. After the WRITE ENABLE command has been decoded and executed, the device sets the write enable latch (WEL) bit.

The WRITE STATUS REGISTER command is entered by driving chip select (S#) LOW, followed by the command code and the data byte on serial data input (DQ0). The WRITE STATUS REGISTER command has no effect on b6, b5, b1 and b0 of the status register. The status register b6 and b5 are always read as '0'. S# must be driven HIGH after the eighth bit of the data byte has been latched in. If not, the WRITE STATUS REGISTER command is not executed.

Figure 12: WRITE STATUS REGISTER Command Sequence

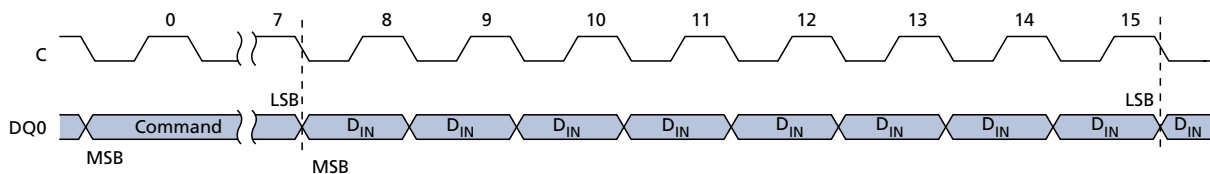

As soon as S# is driven HIGH, the self-timed WRITE STATUS REGISTER cycle is initiated; its duration is t_W . While the WRITE STATUS REGISTER cycle is in progress, the status register may still be read to check the value of the write in progress (WIP) bit. The WIP bit is 1 during the self-timed WRITE STATUS REGISTER cycle, and is 0 when the cycle is completed. Also, when the cycle is completed, the WEL bit is reset.

The WRITE STATUS REGISTER command allows the user to change the values of the block protect bits (BP2, BP1, BP0). Setting these bit values defines the size of the area that is to be treated as read-only, as defined in on page .

The WRITE STATUS REGISTER command also allows the user to set and reset the status register write disable (SRWD) bit in accordance with the write protect (W#/V_{PP}) signal. The SRWD bit and the W#/V_{PP} signal allow the device to be put in the HARDWARE PROTECTED (HPM) mode. The WRITE STATUS REGISTER command is not executed once the HPM is entered. The options for enabling the status register protection modes are summarized here.

Table 7: Status Register Protection Modes

W/V _{PP} Signal	SRWD Bit	Protection Mode (PM)	Status Register Write Protection	Memory Content		Notes
				Protected Area	Unprotected Area	
1	0	SOFTWARE PROTECTED mode (SPM)	Software protection	Commands not accepted	Commands accepted	1, 2, 3
0	0					
1	1					

Table 7: Status Register Protection Modes (Continued)

W/V _{PP} Signal	SRWD Bit	Protection Mode (PM)	Status Register Write Protection	Memory Content		Notes
				Protected Area	Unprotected Area	
0	1	HARDWARE PROTECTED mode (HPM)	Hardware protection	Commands not accepted	Commands accepted	3, 4, 5,

- Notes:
1. Software protection: status register is writable (SRWD, BP2, BP1, and BP0 bit values can be changed) if the WRITE ENABLE command has set the WEL bit.
 2. PAGE PROGRAM, SECTOR ERASE, AND BULK ERASE commands are not accepted.
 3. PAGE PROGRAM and SECTOR ERASE commands can be accepted.
 4. Hardware protection: status register is not writable (SRWD, BP2, BP1, and BP0 bit values cannot be changed).
 5. PAGE PROGRAM, SECTOR ERASE, AND BULK ERASE commands are not accepted.

When the SRWD bit of the status register is 0 (its initial delivery state), it is possible to write to the status register provided that the WEL bit has been set previously by a WRITE ENABLE command, regardless of whether the W#/V_{PP} signal is driven HIGH or LOW. When the status register SRWD bit is set to 1, two cases need to be considered depending on the state of the W#/V_{PP} signal:

- If the W#/V_{PP} signal is driven HIGH, it is possible to write to the status register provided that the WEL bit has been set previously by a WRITE ENABLE command.
- If the W#/V_{PP} signal is driven LOW, it is not possible to write to the status register even if the WEL bit has been set previously by a WRITE ENABLE command. Therefore, attempts to write to the status register are rejected, and are not accepted for execution. The result is that all the data bytes in the memory area that have been put in SPM by the status register block protect bits (BP2, BP1, BP0) are also hardware protected against data modification.

Regardless of the order of the two events, the HPM can be entered in either of the following ways:

- Setting the status register SRWD bit after driving the W#/V_{PP} signal LOW
- Driving the W#/V_{PP} signal LOW after setting the status register SRWD bit.

The only way to exit the HPM is to pull the W#/V_{PP} signal HIGH. If the W#/V_{PP} signal is permanently tied HIGH, the HPM can never be activated. In this case, only the SPM is available, using the status register block protect bits (BP2, BP1, BP0).

READ DATA BYTES

The device is first selected by driving chip select (S#) LOW. The command code for READ DATA BYTES is followed by a 3-byte address (A23-A0), each bit being latched-in during the rising edge of serial clock (C). Then the memory contents at that address is shifted out on serial data output (DQ1), each bit being shifted out at a maximum frequency f_R during the falling edge of C.

The first byte addressed can be at any location. The address is automatically incremented to the next higher address after each byte of data is shifted out. Therefore, the entire memory can be read with a single READ DATA BYTES command. When the highest address is reached, the address counter rolls over to 000000h, allowing the read sequence to be continued indefinitely.

The READ DATA BYTES command is terminated by driving S# HIGH. S# can be driven HIGH at any time during data output. Any READ DATA BYTES command issued while an ERASE, PROGRAM, or WRITE cycle is in progress is rejected without any effect on the cycle that is in progress.

Figure 13: READ DATA BYTES Command Sequence

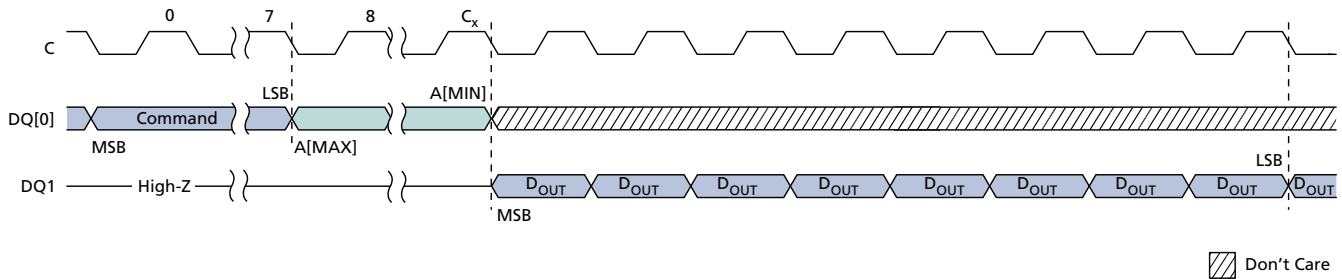

Note: 1. $C_x = 7 + (A[MAX] + 1)$.

READ DATA BYTES at HIGHER SPEED

The device is first selected by driving chip select (S#) LOW. The command code for the READ DATA BYTES at HIGHER SPEED command is followed by a 3-byte address (A23-A0) and a dummy byte, each bit being latched-in during the rising edge of serial clock (C). Then the memory contents at that address are shifted out on serial data output (DQ1) at a maximum frequency f_C , during the falling edge of C.

The first byte addressed can be at any location. The address is automatically incremented to the next higher address after each byte of data is shifted out. Therefore, the entire memory can be read with a single READ DATA BYTES at HIGHER SPEED command. When the highest address is reached, the address counter rolls over to 000000h, allowing the read sequence to be continued indefinitely.

The READ DATA BYTES at HIGHER SPEED command is terminated by driving S# HIGH. S# can be driven HIGH at any time during data output. Any READ DATA BYTES at HIGHER SPEED command issued while an ERASE, PROGRAM, or WRITE cycle is in progress is rejected without any effect on the cycle that is in progress.

Figure 14: READ DATA BYTES at HIGHER SPEED Command Sequence

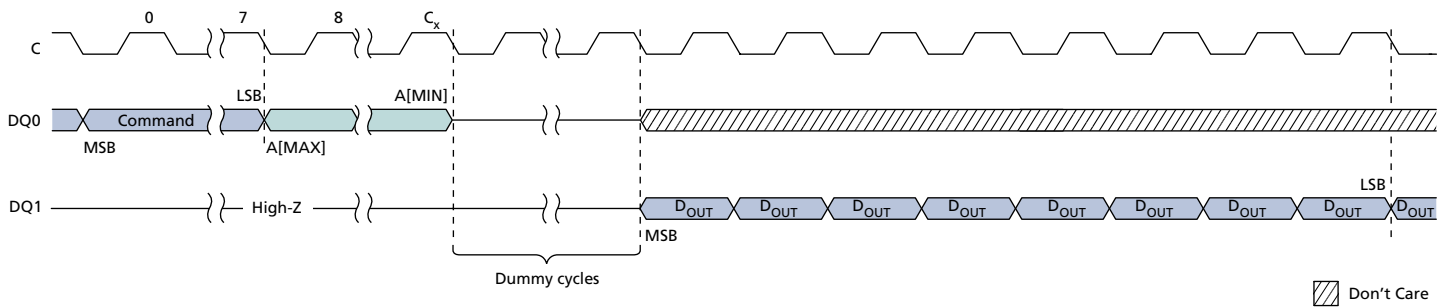

Note: 1. $C_x = 7 + (A[23] + 1)$.

PAGE PROGRAM

The PAGE PROGRAM command allows bytes in the memory to be programmed, which means the bits are changed from 1 to 0. Before a PAGE PROGRAM command can be accepted a WRITE ENABLE command must be executed. After the WRITE ENABLE command has been decoded, the device sets the write enable latch (WEL) bit.

The PAGE PROGRAM command is entered by driving chip select (S#) LOW, followed by the command code, three address bytes, and at least one data byte on serial data input (DQ0).

If the eight least significant address bits (A7-A0) are not all zero, all transmitted data that goes beyond the end of the current page are programmed from the start address of the same page; that is, from the address whose eight least significant bits (A7-A0) are all zero. S# must be driven LOW for the entire duration of the sequence.

If more than 256 bytes are sent to the device, previously latched data are discarded and the last 256 data bytes are guaranteed to be programmed correctly within the same page. If less than 256 data bytes are sent to device, they are correctly programmed at the requested addresses without any effects on the other bytes of the same page.

For optimized timings, it is recommended to use the PAGE PROGRAM command to program all consecutive targeted bytes in a single sequence rather than to use several PAGE PROGRAM sequences, each containing only a few bytes.

S# must be driven HIGH after the eighth bit of the last data byte has been latched in. Otherwise the PAGE PROGRAM command is not executed.

As soon as S# is driven HIGH, the self-timed PAGE PROGRAM cycle is initiated; the cycle's duration is t_{pp} . While the PAGE PROGRAM cycle is in progress, the status register may be read to check the value of the write in progress (WIP) bit. The WIP bit is 1 during the self-timed PAGE PROGRAM cycle, and 0 when the cycle is completed. At some unspecified time before the cycle is completed, the write enable latch (WEL) bit is reset.

A PAGE PROGRAM command is not executed if it applies to a page protected by the block protect bits BP2, BP1, and BP0.

Figure 15: PAGE PROGRAM Command Sequence

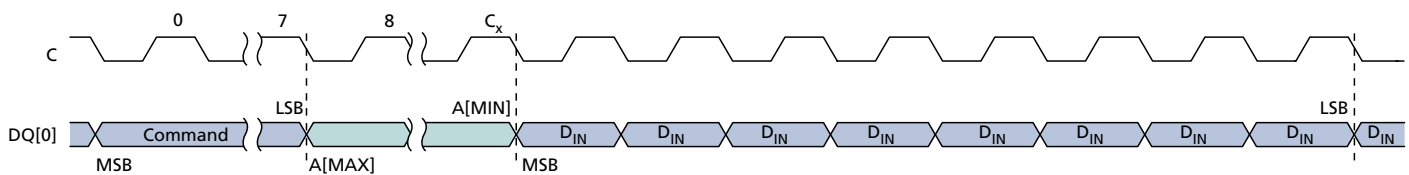

Note: 1. $C_x = 7 + (A[MSB] + 1)$.

SECTOR ERASE

The SECTOR ERASE command sets to 1 (FFh) all bits inside the chosen sector. Before the SECTOR ERASE command can be accepted, a WRITE ENABLE command must have been executed previously. After the WRITE ENABLE command has been decoded, the device sets the write enable latch (WEL) bit.

The SECTOR ERASE command is entered by driving chip select (S#) LOW, followed by the command code, and three address bytes on serial data input (DQ0). Any address inside the sector is a valid address for the SECTOR ERASE command. S# must be driven LOW for the entire duration of the sequence.

S# must be driven HIGH after the eighth bit of the last address byte has been latched in. Otherwise the SECTOR ERASE command is not executed. As soon as S# is driven HIGH, the self-timed SECTOR ERASE cycle is initiated; the cycle's duration is t_{SE} . While the SECTOR ERASE cycle is in progress, the status register may be read to check the value of the write in progress (WIP) bit. The WIP bit is 1 during the self-timed SECTOR ERASE cycle, and is 0 when the cycle is completed. At some unspecified time before the cycle is completed, the WEL bit is reset.

A SECTOR ERASE command is not executed if it applies to a page that is protected by the block protect bits BP2, BP1, and BP0.

Figure 16: SECTOR ERASE Command Sequence

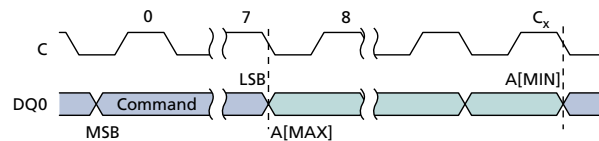

Note: 1. $C_x = 7 + (A[MAX] + 1)$.

BULK ERASE

The BULK ERASE command sets all bits to 1 (FFh). Before the BULK ERASE command can be accepted, a WRITE ENABLE command must have been executed previously. After the WRITE ENABLE command has been decoded, the device sets the write enable latch (WEL) bit.

The BULK ERASE command is entered by driving chip select (S#) LOW, followed by the command code on serial data input (DQ0). S# must be driven LOW for the entire duration of the sequence.

S# must be driven HIGH after the eighth bit of the command code has been latched in. Otherwise the BULK ERASE command is not executed. As soon as S# is driven HIGH, the self-timed BULK ERASE cycle is initiated; the cycle's duration is t_{BE} . While the BULK ERASE cycle is in progress, the status register may be read to check the value of the write In progress (WIP) bit. The WIP bit is 1 during the self-timed BULK ERASE cycle, and is 0 when the cycle is completed. At some unspecified time before the cycle is completed, the WEL bit is reset.

The BULK ERASE command is executed only if all block protect (BP2, BP1, BP0) bits are 0. The BULK ERASE command is ignored if one or more sectors are protected.

Figure 17: BULK ERASE Command Sequence

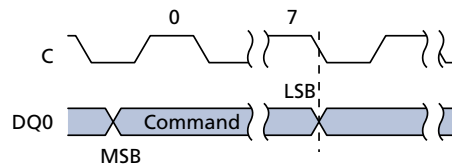

DEEP POWER-DOWN

Executing the DEEP POWER-DOWN command is the only way to put the device in the lowest power consumption mode, the DEEP POWER-DOWN mode. The DEEP POWER-DOWN command can also be used as a software protection mechanism while the device is not in active use because in the DEEP POWER-DOWN mode the device ignores all WRITE, PROGRAM, and ERASE commands.

Driving chip select (S#) HIGH deselects the device, and puts it in the STANDBY POWER mode if there is no internal cycle currently in progress. Once in STANDBY POWER mode, the DEEP POWER-DOWN mode can be entered by executing the DEEP POWER-DOWN command, subsequently reducing the standby current from I_{CC1} to I_{CC2} .

To take the device out of DEEP POWER-DOWN mode, the RELEASE from DEEP POWER-DOWN command must be issued. Other commands must not be issued while the device is in DEEP POWER-DOWN mode. The DEEP POWER-DOWN mode stops automatically at power-down. The device always powers up in STANDBY POWER mode.

The DEEP POWER-DOWN command is entered by driving S# LOW, followed by the command code on serial data input (DQ0). S# must be driven LOW for the entire duration of the sequence.

S# must be driven HIGH after the eighth bit of the command code has been latched in. Otherwise the DEEP POWER-DOWN command is not executed. As soon as S# is driven HIGH, it requires a delay of t_{DP} before the supply current is reduced to I_{CC2} and the DEEP POWER-DOWN mode is entered.

Any DEEP POWER-DOWN command issued while an ERASE, PROGRAM, or WRITE cycle is in progress is rejected without any effect on the cycle that is in progress.

Figure 18: DEEP POWER-DOWN Command Sequence

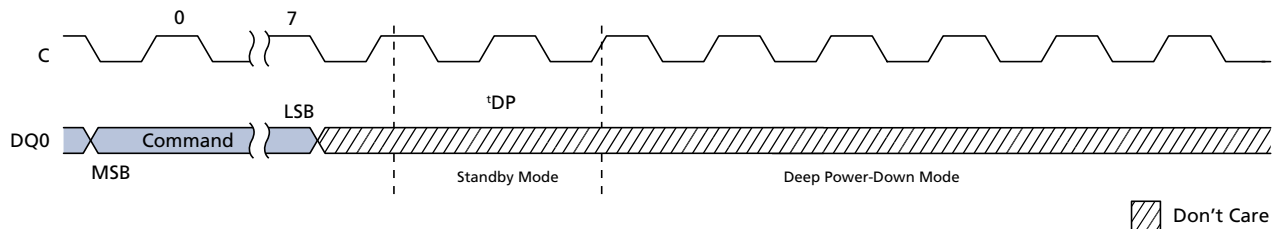

RELEASE from DEEP POWER-DOWN

Once the device has entered DEEP POWER-DOWN mode, all commands are ignored except RELEASE from DEEP POWER-DOWN and READ ELECTRONIC SIGNATURE. Executing either of these commands takes the device out of the DEEP POWER-DOWN mode.

The RELEASE from DEEP POWER-DOWN command is entered by driving chip select (S#) LOW, followed by the command code on serial data input (DQ0). S# must be driven LOW for the entire duration of the sequence.

The RELEASE from DEEP POWER-DOWN command is terminated by driving S# high. Sending additional clock cycles on serial clock C while S# is driven LOW causes the command to be rejected and not executed.

After S# has been driven high, followed by a delay, t_{RES} , the device is put in the STANDBY mode. S# must remain HIGH at least until this period is over. The device waits to be selected so that it can receive, decode, and execute commands.

Any RELEASE from DEEP POWER-DOWN command issued while an ERASE, PROGRAM, or WRITE cycle is in progress is rejected without any effect on the cycle that is in progress.

Figure 19: RELEASE from DEEP POWER-DOWN Command Sequence

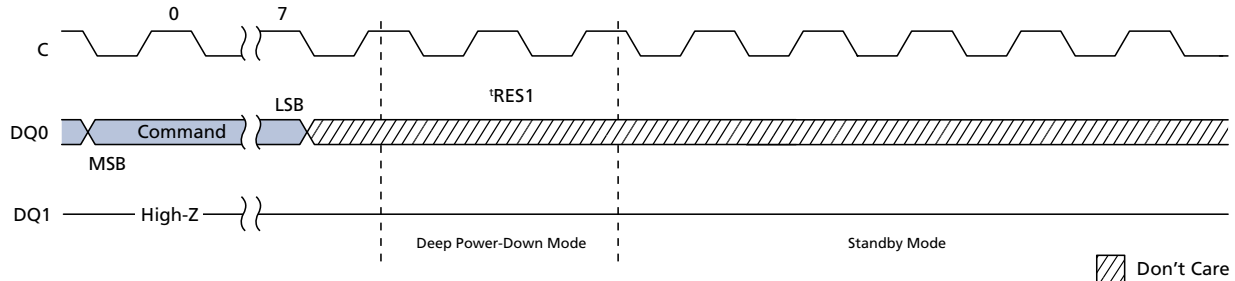

READ ELECTRONIC SIGNATURE

Once the device enters DEEP POWER-DOWN mode, all commands are ignored except READ ELECTRONIC SIGNATURE and RELEASE from DEEP POWER-DOWN. Executing either of these commands takes the device out of the DEEP POWER-DOWN mode.

The READ ELECTRONIC SIGNATURE command is entered by driving chip select (S#) LOW, followed by the command code and three dummy bytes on serial data input (DQ0). Each bit is latched in on the rising edge of serial clock C. The 8-bit electronic signature is shifted out on serial data output DQ1 on the falling edge of C; S# must be driven LOW the entire duration of the sequence for the electronic signature to be read. However, driving S# HIGH after the command code, but before the entire 8-bit electronic signature has been output for the first time, still ensures that the device is put into STANDBY mode.

Except while an ERASE, PROGRAM, or WRITE STATUS REGISTER cycle is in progress, the READ ELECTRONIC SIGNATURE command provides access to the 8-bit electronic signature of the device, and can be applied even if DEEP POWER-DOWN mode has not been entered. The READ ELECTRONIC SIGNATURE command is not executed while an ERASE, PROGRAM, or WRITE STATUS REGISTER cycle is in progress and has no effect on the cycle in progress.

The READ ELECTRONIC SIGNATURE command is terminated by driving S# high after the electronic signature has been read at least once. Sending additional clock cycles C while S# is driven LOW causes the electronic signature to be output repeatedly.

If S# is driven HIGH, the device is put in STANDBY mode immediately unless it was previously in DEEP POWER-DOWN mode. If previously in DEEP POWER-DOWN mode, the device transitions to STANDBY mode with delay as described here. Once in STANDBY mode, the device waits to be selected so that it can receive, decode, and execute instructions.

- If S# is driven HIGH before the electronic signature is read, transition to STANDBY mode is delayed by tRES1, as shown in the RELEASE from DEEP POWER-DOWN command sequence. S# must remain HIGH for at least tRES1(max).
- If S# is driven HIGH after the electronic signature is read, transition to STANDBY mode is delayed by tRES2. S# must remain HIGH for at least tRES2(max).

Figure 20: READ ELECTRONIC SIGNATURE Command Sequence

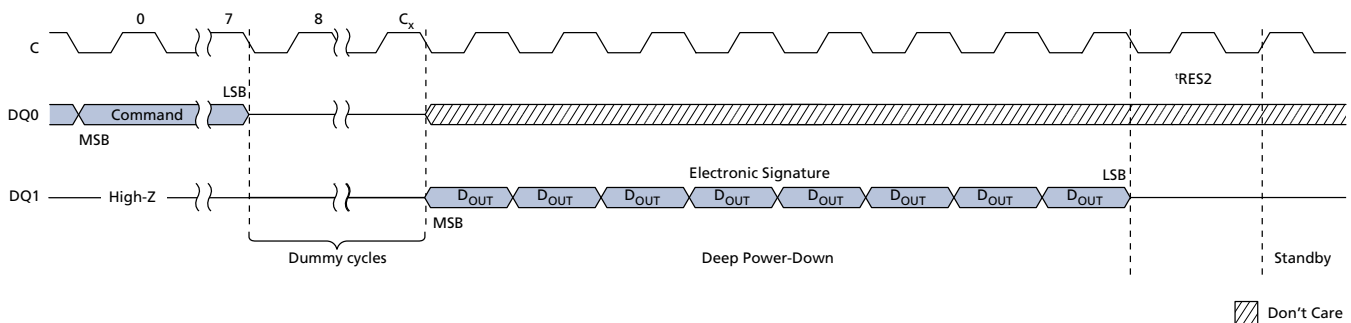

Note: 1. $C_x = 7 + (A[\text{MAX}] + 1)$.

Power-Up/Down and Supply Line Decoupling

At power-up and power-down, the device must not be selected; that is, chip select (S#) must follow the voltage applied on V_{CC} until V_{CC} reaches the correct value:

- $V_{CC}(\text{min})$ at power-up, and then for a further delay of t_{VSL}
- V_{SS} at power-down

A safe configuration is provided under the SPI modes heading, beginning with SPI Modes (page 9).

To avoid data corruption and inadvertent write operations during power-up, a power-on-reset (POR) circuit is included. The logic inside the device is held reset while V_{CC} is less than the POR threshold voltage, V_{WI} – all operations are disabled, and the device does not respond to any instruction. Moreover, the device ignores the following instructions until a time delay of t_{PUW} has elapsed after the moment that V_{CC} rises above the V_{WI} threshold:

- WRITE ENABLE,
- PAGE PROGRAM
- SECTOR ERASE
- BULK ERASE
- WRITE STATUS REGISTER

However, the correct operation of the device is not guaranteed if, by this time, V_{CC} is still below $V_{CC}(\text{min})$. No WRITE STATUS REGISTER, PROGRAM, or ERASE instruction should be sent until:

- t_{PUW} after V_{CC} has passed the V_{WI} threshold
- t_{VSL} after V_{CC} has passed the $V_{CC}(\text{min})$ level.

If the time, t_{VSL} , has elapsed, after V_{CC} rises above $V_{CC}(\text{min})$, the device can be selected for READ instructions even if the t_{PUW} delay has not yet fully elapsed.

V_{PPH} must be applied only when V_{CC} is stable and in the $V_{CC\text{min}}$ to $V_{CC\text{max}}$ voltage range.

Figure 21: Power-Up Timing

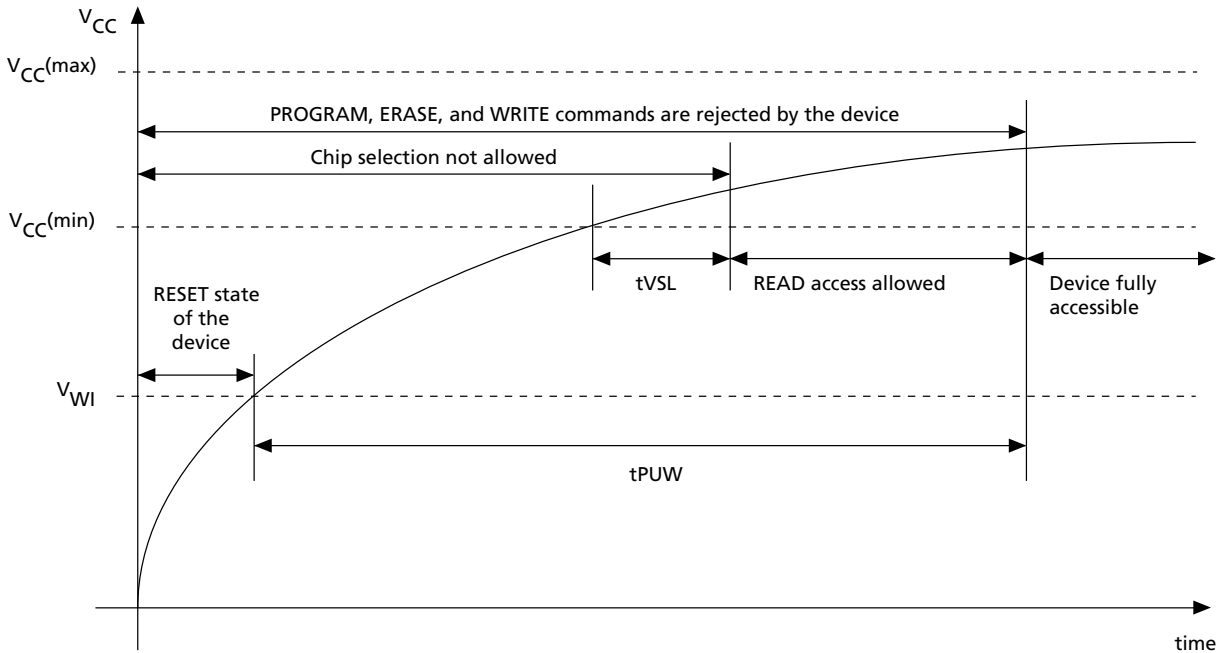

After power-up, the device is in the following state:

- Standby Power mode (not the Deep Power-down mode).
- Write enable latch (WEL) bit is reset.
- Write in progress (WIP) bit is reset.

Normal precautions must be taken for supply line decoupling to stabilize the V_{CC} supply. Each device in a system should have the V_{CC} line decoupled by a suitable capacitor close to the package pins; generally, this capacitor is of the order of 100 nF.

At power-down, when V_{CC} drops from the operating voltage to below the POR threshold voltage V_{WI} , all operations are disabled and the device does not respond to any instruction.

Note: Designers need to be aware that if power-down occurs while a WRITE, PROGRAM, OR ERASE cycle is in progress, some data corruption may result.



Power-Up Timing and Write Inhibit Voltage Specifications

Table 8: Power-Up Timing and V_{WI} Threshold

Symbol	Parameter	Min	Max	Unit
t_{VSL}	$V_{CC}(\text{min})$ to S# LOW	10	–	μs
t_{PUW}	Time delay to write instruction	1.0	10	ms
V_{WI}	Write Inhibit voltage (device grade 3)	1.0	2.1	V
V_{WI}	Write Inhibit voltage (device grade 6)	1.0	2.1	V

Note: 1. Parameters are characterized only.

If the time, t_{VSL} , has elapsed, after V_{CC} rises above $V_{CC}(\text{min})$, the device can be selected for READ instructions even if the t_{PUW} delay has not yet fully elapsed.

V_{PPH} must be applied only when V_{CC} is stable and in the $V_{CC\text{min}}$ to $V_{CC\text{max}}$ voltage range.

Maximum Ratings and Operating Conditions

Caution: Stressing the device beyond the absolute maximum ratings may cause permanent damage to the device. These are stress ratings only and operation of the device beyond any specification or condition in the operating sections of this datasheet is not recommended. Exposure to absolute maximum rating conditions for extended periods may affect device reliability.

Table 9: Absolute Maximum Ratings

Symbol	Parameter	Min	Max	Units	Notes
T _{STG}	Storage temperature	-65	150	°C	
T _{LEAD}	Lead temperature during soldering	—	See note	°C	1
V _{IO}	Input and output voltage (with respect to ground)	-0.6	V _{CC} +0.6	V	2
V _{CC}	Supply voltage	-0.6	4.0	V	
V _{ESD}	Electrostatic discharge voltage (Human Body model)	-2000	2000	V	3

- Notes:
1. The T_{LEAD} signal is compliant with JEDEC Std J-STD-020C (for small body, Sn-Pb or Pb assembly), the Micron RoHS compliant 7191395 specification, and the European directive on Restrictions on Hazardous Substances (RoHS) 2002/95/EU.
 2. The minimum voltage may reach the value of -2V for no more than 20ns during transitions; the maximum may reach the value of V_{CC} +2V for no more than 20ns during transitions.
 3. The V_{ESD} signal: JEDEC Std JESD22-A114A (C1 = 100 pF, R1 = 1500 Ω, R2 = 500 Ω).

Table 10: Operating Conditions

Symbol	Parameter	Min	Max	Unit
V _{CC}	Supply voltage	2.3	3.6	V
T _A	Ambient operating temperature (grade 6)	-40	85	°C
T _A	Ambient operating temperature (grade 3)	-40	125	°C

Table 11: Data Retention and Endurance

Parameter	Condition	Min	Max	Unit
Program/Erase Cycles	Grade 6, Grade 3	100,000	—	Cycles per unit
Data Retention	at 55°C	20	—	Years

Electrical Characteristics

Table 12: DC Current Specifications (Device Grade 6)

Symbol	Parameter	Test Conditions	Min	Max	Units
I_{LI}	Input leakage current	–	–	± 2	μA
I_{LO}	Output leakage current	–	–	± 2	μA
I_{CC1}	Standby current	$S\# = V_{CC}, V_{IN} = V_{SS} \text{ or } V_{CC}$	–	50	μA
I_{CC2}	Deep power-down current	$S\# = V_{CC}, V_{IN} = V_{SS} \text{ or } V_{CC}$	–	10	μA
I_{CC3}	Operating current (READ)	$C = 0.1V_{CC} / 0.9V_{CC}$ at 40MHz, 50MHz, and 75MHz, DQ1 = open	–	8	mA
		$C = 0.1V_{CC} / 0.9V_{CC}$ at 25MHz and 33MHz, DQ1 = open	–	4	mA
I_{CC4}	Operating current (PAGE PROGRAM)	$S\# = V_{CC}$	–	15	mA
I_{CC5}	Operating current (WRITE STATUS REGISTER)	$S\# = V_{CC}$	–	15	mA
I_{CC6}	Operating current (SECTOR ERASE)	$S\# = V_{CC}$	–	15	mA
I_{CC7}	Operating current (BULK ERASE)	$S\# = V_{CC}$	–	15	mA

Table 13: DC Voltage Specifications (Device Grade 6)

Symbol	Parameter	Test Conditions	Min	Max	Units
V_{IL}	Input LOW voltage	–	–0.5	$0.3V_{CC}$	V
V_{IH}	Input HIGH voltage	–	$0.7V_{CC}$	$V_{CC}+0.4$	V
V_{OL}	Output LOW voltage	$I_{OL} = 1.6mA$	–	0.4	V
V_{OH}	Output HIGH voltage	$I_{OH} = -100\mu A$	$V_{CC}-0.2$	–	V

Table 14: DC Current Specifications (Device Grade 3)

Symbol	Parameter	Test Conditions	Min	Max	Units
I_{LI}	Input leakage current	–	–	± 2	μA
I_{LO}	Output leakage current	–	–	± 2	μA
I_{CC1}	Standby current	$S\# = V_{CC}, V_{IN} = V_{SS} \text{ or } V_{CC}$	–	100	μA
I_{CC2}	Deep power-down current	$S\# = V_{CC}, V_{IN} = V_{SS} \text{ or } V_{CC}$	–	50	μA
I_{CC3}	Operating current (READ)	$C = 0.1V_{CC} / 0.9V_{CC}$ at 40MHz, 50MHz, and 75MHz, DQ1 = open	–	8	mA
		$C = 0.1V_{CC} / 0.9V_{CC}$ at 25MHz and 33MHz, DQ1 = open	–	4	mA
I_{CC4}	Operating current (PAGE PROGRAM)	$S\# = V_{CC}$	–	15	mA

Table 14: DC Current Specifications (Device Grade 3) (Continued)

Symbol	Parameter	Test Conditons	Min	Max	Units
I_{CC5}	Operating current (WRITE STATUS REGISTER)	$S\# = V_{CC}$	–	15	mA
I_{CC6}	Operating current (SECTOR ERASE)	$S\# = V_{CC}$	–	15	mA
I_{CC7}	Operating current (BULK ERASE)	$S\# = V_{CC}$	–	15	mA

Table 15: DC Voltage Specifications (Device Grade 3)

Symbol	Parameter	Test Conditons	Min	Max	Units
V_{IL}	Input LOW voltage	–	–0.5	$0.3V_{CC}$	V
V_{IH}	Input HIGH voltage	–	$0.7V_{CC}$	$V_{CC}+0.4$	V
V_{OL}	Output LOW voltage	$I_{OL} = 1.6\text{mA}$	–	0.4	V
V_{OH}	Output HIGH voltage	$I_{OH} = -100\mu\text{A}$	$V_{CC}-0.2$	–	V

AC Characteristics

In the following AC specifications, output HIGH-Z is defined as the point where data out is no longer driven; however, this is not applicable to the M25PX64 device.

Table 16: Device Grade and AC Table Correlation

Device Grade	150nm			110nm		
	V _{CC} [min]	f[<i>min</i>]	AC Table	V _{CC} [min]	f[<i>min</i>]	AC Table
Grade 3	2.7V	25MHz	Table 21 (page 40)	2.7V	75MHz	Table 24 (page 44)
Grade 6	2.3V	40MHz	Table 23 (page 42)	2.3V	40MHz	Table 23 (page 42)
Grade 6	2.7V	50MHz	Table 22 (page 41)	2.7V	75MHz	Table 24 (page 44)

Table 17: AC Measurement Conditions

Symbol	Parameter	Min	Max	Unit
C _L	Load capacitance	30	30	pF
	Input rise and fall times	–	5	ns
	Input pulse voltages	0.2V _{CC}	0.8V _{CC}	V
	Input timing reference voltages	0.3V _{CC}	0.7V _{CC}	V
	Output timing reference voltages	V _{CC} / 2	V _{CC} / 2	V

Figure 22: AC Measurement I/O Waveform

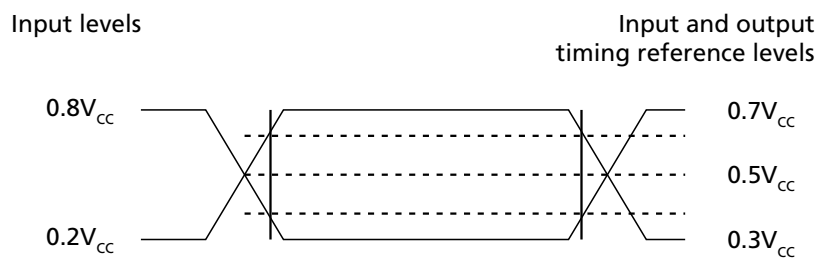

Table 18: Capacitance

Symbol	Parameter	Test condition	Min	Max	Unit	Notes
C _{OUT}	Output capacitance (DQ1)	V _{OUT} = 0 V	–	8	pF	1
C _{IN}	Input capacitance (other pins)	V _{IN} = 0 V	–	6	pF	

Note: 1. Values are sampled only, not 100% tested, at T_A=25°C and a frequency of 25MHz.

Table 19: Instruction Times, Process Technology 110nm

Symbol	Parameter	Min	Typ	Max	Units	Notes
t_W	WRITE STATUS REGISTER cycle time	–	1.3	15	ms	
t_{PP}	PAGE PROGRAM cycle time (256 bytes)	–	0.8	5	ms	2
t_{PP}	PAGE PROGRAM cycle time (n bytes)	–	$\text{int}(n/8) \times 0.025$			
t_{SE}	SECTOR ERASE cycle time	–	0.6	3	s	
t_{BE}	BULK ERASE cycle time	–	4.5	10	s	

- Notes:
1. Applies to the entire table: 110nm technology devices are identified by the process identification digit *4* in the device marking and the process letter *B* in the part number.
 2. When using the PAGE PROGRAM command to program consecutive bytes, optimized timings are obtained in one sequence that includes all the bytes rather than in several sequences of only a few bytes ($1 \leq n \leq 256$).

Table 20: Instruction Times, Process Technology 150nm

Symbol	Parameter	Min	Typ	Max	Units	Notes
t_W	WRITE STATUS REGISTER cycle time	–	5	15	ms	
t_{PP}	PAGE PROGRAM cycle time (256 bytes)	–	1.4	5	ms	2
t_{PP}	PAGE PROGRAM cycle time (n bytes)	–	$0.4+n \times 1/256$			
t_{SE}	SECTOR ERASE cycle time	–	1.0	3	s	
t_{BE}	BULK ERASE cycle time	–	4.5	10	s	

- Notes:
1. Applies to the entire table: 150nm technology devices are identified by the process identification digit *4* in the device marking and the process letter *B* in the part number.
 2. When using the PAGE PROGRAM command to program consecutive bytes, optimized timings are obtained in one sequence that includes all the bytes rather than in several sequences of only a few bytes ($1 \leq n \leq 256$).

Table 21: AC Specifications (25 MHz, Device Grade 3, $V_{CC}[\text{min}] = 2.7\text{V}$)

Symbol	Alt.	Parameter	Min	Typ	Max	Unit	Notes
f_C	f_C	Clock frequency for commands (See note)	D.C.	–	25	MHz	1
f_R	–	Clock frequency for READ command	D.C.	–	20	MHz	
t_{CH}	t_{CLH}	Clock HIGH time	18	–	–	ns	2
t_{CL}	t_{CLL}	Clock LOW time	18	–	–	ns	2
t_{CLCH}	–	Clock rise time (peak to peak)	0.1	–	–	V/ns	3, 4
t_{CHCL}	–	Clock fall time (peak to peak)	0.1	–	–	V/ns	3, 4
t_{SLCH}	t_{CSS}	S# active setup time (relative to C)	10	–	–	ns	
t_{CHSL}	—	S# not active hold time (relative to C)	10	–	–	ns	
t_{DVCH}	t_{DSU}	Data in setup time	5	–	–	ns	
t_{CHDX}	t_{DH}	Data in hold time	5	–	–	ns	
t_{CHSH}	–	S# active hold time (relative to C)	10	–	–	ns	
t_{SHCH}	–	S# not active setup time (relative to C)	10	–	–	ns	

Table 21: AC Specifications (25 MHz, Device Grade 3, $V_{CC}[\min]=2.7V$) (Continued)

Symbol	Alt.	Parameter	Min	Typ	Max	Unit	Notes
t_{SHSL}	t_{CSH}	S# deselect time	100	–	–	ns	
t_{SHQZ}	t_{DIS}	Output disable time	–	–	15	ns	3
t_{CLQV}	t_V	Clock LOW to output valid	–	–	15	ns	
t_{CLQX}	t_{HO}	Output hold time	0	–	–	ns	
t_{HLCH}	–	HOLD# setup time (relative to C)	10	–	–	ns	
t_{CHHH}	–	HOLD# hold time (relative to C)	10	–	–	ns	
t_{HHCH}	–	HOLD# setup time (relative to C)	10	–	–	ns	
t_{CHHL}	–	HOLD# hold time (relative to C)	10	–	–	ns	
t_{HHQX}	t_{LZ}	HOLD# to output LOW-Z	–	–	15	ns	3
t_{HLQZ}	t_{HZ}	HOLD# to output HIGH-Z	–	–	20	ns	3
t_{WHSL}	–	WRITE PROTECT setup time	20	–	–	ns	5
t_{SHWL}	–	WRITE PROTECT hold time	100	–	–	ns	5
t_{DP}	–	S# HIGH to DEEP POWER-DOWN mode	–	–	3	μs	3
t_{RES1}	–	S# HIGH to STANDBY without electronic signature read	–	–	30	μs	3
t_{RES2}	–	S# HIGH to STANDBY with electronic signature read	–	–	30	μs	3

- Notes:
1. READ DATA BYTES at HIGHER SPEED, PAGE PROGRAM, SECTOR ERASE, BLOCK ERASE, DEEP POWER-DOWN, READ ELECTRONIC SIGNATURE, WRITE ENABLE/DISABLE, READ ID, READ/WRITE STATUS REGISTER
 2. The t_{CH} and t_{CL} signals must be greater than or equal to $1/f_C$.
 3. The t_{CLCH} , t_{CHCL} , t_{SHQZ} , t_{HHQX} , t_{HLQZ} , t_{DP} , t_{RES1} , and t_{RES2} signal values are guaranteed by characterization, not 100% tested in production.
 4. The t_{CLCH} and t_{CHCL} signals clock rise and fall time values are expressed as a slew-rate.
 5. The t_{WHSL} and t_{SHWL} signals are only applicable as a constraint for a WRITE STATUS REGISTER command when SRWD bit is set at 1.

Table 22: AC Specifications (50 MHz, Device Grade 6, $V_{CC}[\min]=2.7V$)

Symbol	Alt.	Parameter	Min	Typ	Max	Unit	Notes
f_C	f_C	Clock frequency for commands (See note)	D.C.	–	50	MHz	1
f_R	–	Clock frequency for READ command	D.C.	–	25	MHz	
t_{CH}	t_{CLH}	Clock HIGH time	9	–	–	ns	2
t_{CL}	t_{CLL}	Clock LOW time	9	–	–	ns	2
t_{CLCH}	–	Clock rise time (peak to peak)	0.1	–	–	V/ns	3, 4
t_{CHCL}	–	Clock fall time (peak to peak)	0.1	–	–	V/ns	3, 4
t_{SLCH}	t_{CSS}	S# active setup time (relative to C)	5	–	–	ns	
t_{CHSL}	–	S# not active hold time (relative to C)	5	–	–	ns	
t_{DVCH}	t_{DSU}	Data in setup time	2	–	–	ns	
t_{CHDX}	t_{DH}	Data in hold time	5	–	–	ns	
t_{CHSH}	–	S# active hold time (relative to C)	5	–	–	ns	
t_{SHCH}	–	S# not active setup time (relative to C)	5	–	–	ns	

Table 22: AC Specifications (50 MHz, Device Grade 6, V_{CC}[min]=2.7V) (Continued)

Symbol	Alt.	Parameter	Min	Typ	Max	Unit	Notes
t _{SHSL}	t _{CSH}	S# deselect time	100	–	–	ns	
t _{SHQZ}	t _{DIS}	Output disable time	–	–	8	ns	3
t _{CLQV}	t _V	Clock LOW to output valid	–	–	8	ns	
t _{CLQX}	t _{HO}	Output hold time	0	–	–	ns	
t _{HLCH}	–	HOLD# setup time (relative to C)	5	–	–	ns	
t _{CHHH}	–	HOLD# hold time (relative to C)	5	–	–	ns	
t _{HHCH}	–	HOLD# setup time (relative to C)	5	–	–	ns	
t _{CHHL}	–	HOLD# hold time (relative to C)	5	–	–	ns	
t _{HHQX}	t _{LZ}	HOLD# to output LOW-Z	–	–	8	ns	3
t _{HLQZ}	t _{HZ}	HOLD# to output HIGH-Z	–	–	8	ns	3
t _{WHSL}	–	WRITE PROTECT setup time	20	–	–	ns	5
t _{SHWL}	–	WRITE PROTECT hold time	100	–	–	ns	5
t _{DP}	–	S# HIGH to DEEP POWER-DOWN mode	–	–	3	μs	3
t _{RES1}	–	S# HIGH to STANDBY without electronic signature read	–	–	30	μs	3
t _{RES2}	–	S# HIGH to STANDBY with electronic signature read	–	–	30	μs	3

- Notes:
1. READ DATA BYTES at HIGHER SPEED, PAGE PROGRAM, SECTOR ERASE, BLOCK ERASE, DEEP POWER-DOWN, READ ELECTRONIC SIGNATURE, WRITE ENABLE/DISABLE, READ ID, READ/WRITE STATUS REGISTER
 2. The t_{CH} and t_{CL} signals must be greater than or equal to 1/f_C.
 3. The t_{CLCH}, t_{CHCL}, t_{SHQZ}, t_{HHQX}, t_{HLQZ}, t_{DP}, t_{RES1}, and t_{RES2} signal values are guaranteed by characterization, not 100% tested in production.
 4. The t_{CLCH} and t_{CHCL} signals clock rise and fall time values are expressed as a slew-rate.
 5. The t_{WHSL} and t_{SHWL} signals are only applicable as a constraint for a WRITE STATUS REGISTER command when SRWD bit is set at 1.

Table 23: AC Specifications (40 MHz, Device Grade 6, V_{CC}[min]=2.3V)

Symbol	Alt.	Parameter	Min	Typ	Max	Unit	Notes
f _C	f _C	Clock frequency for commands (See note)	D.C.	–	40	MHz	2
f _R	–	Clock frequency for READ command	D.C.	–	25	MHz	
t _{CH}	t _{CLH}	Clock HIGH time	11	–	–	ns	3
t _{CL}	t _{CLL}	Clock LOW time	11	–	–	ns	3
t _{CLCH}	–	Clock rise time (peak to peak)	0.1	–	–	V/ns	4, 5
t _{CHCL}	–	Clock fall time (peak to peak)	0.1	–	–	V/ns	4, 5
t _{SLCH}	t _{CSS}	S# active setup time (relative to C)	5	–	–	ns	
t _{CHSL}	–	S# not active hold time (relative to C)	5	–	–	ns	
t _{DVCH}	t _{DSU}	Data in setup time	2	–	–	ns	
t _{CHDX}	t _{DH}	Data in hold time	5	–	–	ns	
t _{CHSH}	–	S# active hold time (relative to C)	5	–	–	ns	
t _{SHCH}	–	S# not active setup time (relative to C)	5	–	–	ns	

Table 23: AC Specifications (40 MHz, Device Grade 6, $V_{CC}[\min]=2.3V$) (Continued)

Symbol	Alt.	Parameter	Min	Typ	Max	Unit	Notes
t_{SHSL}	t_{CSH}	S# deselect time	100	–	–	ns	
t_{SHQZ}	t_{DIS}	Output disable time	–	–	8	ns	4
t_{CLQV}	t_V	Clock LOW to output valid	–	–	8	ns	
t_{CLQX}	t_{HO}	Output hold time	0	–	–	ns	
t_{HLCH}	–	HOLD# setup time (relative to C)	5	–	–	ns	
t_{CHHH}	–	HOLD# hold time (relative to C)	5	–	–	ns	
t_{HHCH}	–	HOLD# setup time (relative to C)	5	–	–	ns	
t_{CHHL}	–	HOLD# hold time (relative to C)	5	–	–	ns	
t_{HHQX}	t_{LZ}	HOLD# to output LOW-Z	–	–	8	ns	4
t_{HLQZ}	t_{HZ}	HOLD# to output HIGH-Z	–	–	8	ns	4
t_{WHSL}	–	WRITE PROTECT setup time	20	–	–	ns	6
t_{SHWL}	–	WRITE PROTECT hold time	100	–	–	ns	6
t_{DP}	–	S# HIGH to DEEP POWER-DOWN mode	–	–	3	μ s	4
t_{RES1}	–	S# HIGH to STANDBY without electronic signature read	–	–	30	μ s	4
t_{RES2}	–	S# HIGH to STANDBY with electronic signature read	–	–	30	μ s	4

- Notes:
1. Applies to entire table: Maximum frequency in the VCC range 2.3V to 2.7V is 40MHz.
 2. READ DATA BYTES at HIGHER SPEED, PAGE PROGRAM, SECTOR ERASE, BLOCK ERASE, DEEP POWER-DOWN, READ ELECTRONIC SIGNATURE, WRITE ENABLE/DISABLE, READ ID, READ/WRITE STATUS REGISTER
 3. The t_{CH} and t_{CL} signals must be greater than or equal to $1/f_C$.
 4. The t_{CLCH} , t_{CHCL} , t_{SHQZ} , t_{HHQX} , t_{HLQZ} , t_{DP} , t_{RES1} , and t_{RES2} signal values are guaranteed by characterization, not 100% tested in production.
 5. The t_{CLCH} and t_{CHCL} signals clock rise and fall time values are expressed as a slew-rate.
 6. The t_{WHSL} and t_{SHWL} signals are only applicable as a constraint for a WRITE STATUS REGISTER command when SRWD bit is set at 1.

Table 24: AC Specifications (75MHz, Device Grade 3 and 6, $V_{CC}[\min]=2.7V$)

Symbol	Alt.	Parameter	Min	Typ	Max	Unit	Notes
f_C	f_C	Clock frequency for all commands (except READ)	D.C.	–	75	MHz	
f_R	–	Clock frequency for READ command	D.C.	–	33	MHz	
t_{CH}	t_{CLH}	Clock HIGH time	6	–	–	ns	3
t_{CL}	t_{CLL}	Clock LOW time	6	–	–	ns	3, 4
t_{CLCH}	–	Clock rise time (peak to peak)	0.1	–	–	V/ns	5, 6
t_{CHCL}	–	Clock fall time (peak to peak)	0.1	–	–	V/ns	5, 6
t_{SLCH}	t_{CSS}	S# active setup time (relative to C)	5	–	–	ns	
t_{CHSL}		S# not active hold time (relative to C)	5	–	–	ns	
t_{DVCH}	t_{DSU}	Data In setup time	2	–	–	ns	
t_{CHDX}	t_{DH}	Data In hold time	5	–	–	ns	
t_{CHSH}	–	S# active hold time (relative to C)	5	–	–	ns	
t_{SHCH}	–	S# not active setup time (relative to C)	5	–	–	ns	
t_{SHSL}	t_{CSH}	S# deselect time	100	–	–	ns	
t_{SHQZ}	t_{DIS}	Output disable time	–	–	8	ns	5
t_{CLQV}	t_V	Clock LOW to output valid under 30 pF	–	–	8	ns	
		Clock LOW to output valid under 10 pF	–	–	6	ns	
t_{CLQX}	t_{HO}	Output hold time	0	–	–	ns	
t_{HLCH}	–	HOLD# setup time (relative to C)	5	–	–	ns	
t_{CHHH}	–	HOLD# hold time (relative to C)	5	–	–	ns	
t_{HHCH}	–	HOLD# setup time (relative to C)	5	–	–	ns	
t_{CHHL}	–	HOLD# hold time (relative to C)	5	–	–	ns	
t_{HHQX}	t_{LZ}	HOLD# to output LOW-Z	–	–	8	ns	5
t_{HLQZ}	t_{HZ}	HOLD# to output HIGH-Z	–	–	8	ns	5
t_{WHSL}	–	WRITE PROTECT setup time	20	–	–	ns	7
t_{SHWL}	–	WRITE PROTECT hold time	100	–	–	ns	7
t_{DP}	–	S# HIGH to DEEP POWER-DOWN mode	–	–	3	μ s	5
t_{RES1}	–	S# HIGH to STANDBY without READ ELECTRONIC SIGNATURE	–	–	30	μ s	5
t_{RES2}	–	S# HIGH to STANDBY with READ ELECTRONIC SIGNATURE	–	–	30	μ s	5

- Notes:
1. Applies to entire table: 110nm technology devices are identified by the process identification digit 4 in the device marking and the process letter B in the part number.
 2. Applies to entire table: the AC specification values shown here are allowed only on the VCC range 2.7V to 3.6V. Maximum frequency in the VCC range 2.3V to 2.7V is 40MHz.
 3. The t_{CH} and t_{CL} signal values must be greater than or equal to $1/f_C$.
 4. Typical values are given for $T_A = 25^\circ\text{C}$.
 5. The t_{CLCH} , t_{CHCL} , t_{SHQZ} , t_{HHQX} , t_{HLQZ} , t_{DP} , and t_{RDP} signal values are guaranteed by characterization, not 100% tested in production.
 6. The t_{CLCH} and t_{CHCL} signals clock rise and fall time values are expressed as a slew-rate.
 7. The t_{WHSL} and t_{SHWL} signal values are only applicable as a constraint for a WRITE STATUS REGISTER command when SRWD bit is set at 1.

Figure 23: Serial Input Timing

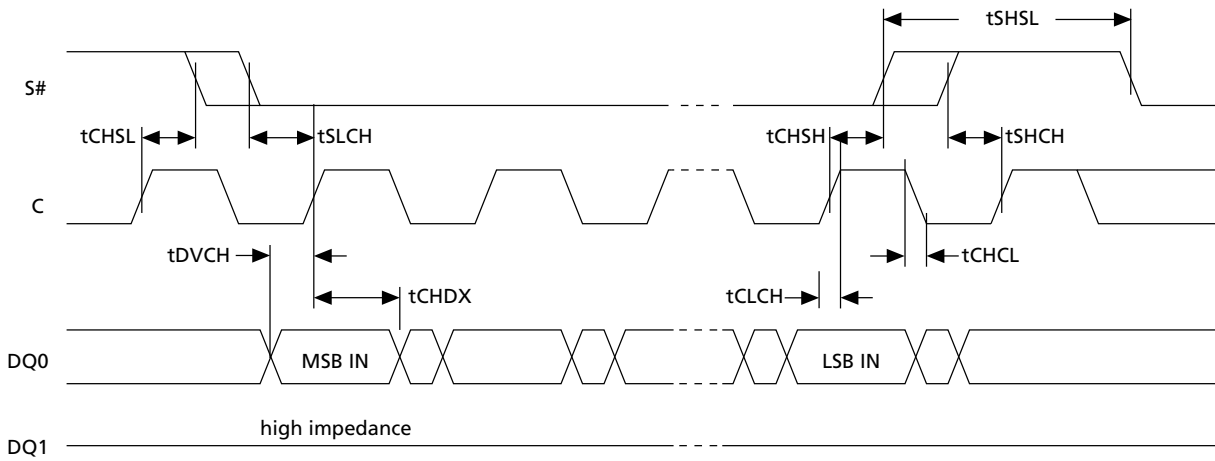

Figure 24: Write Protect Setup and Hold during WRSR when SRWD=1 Timing

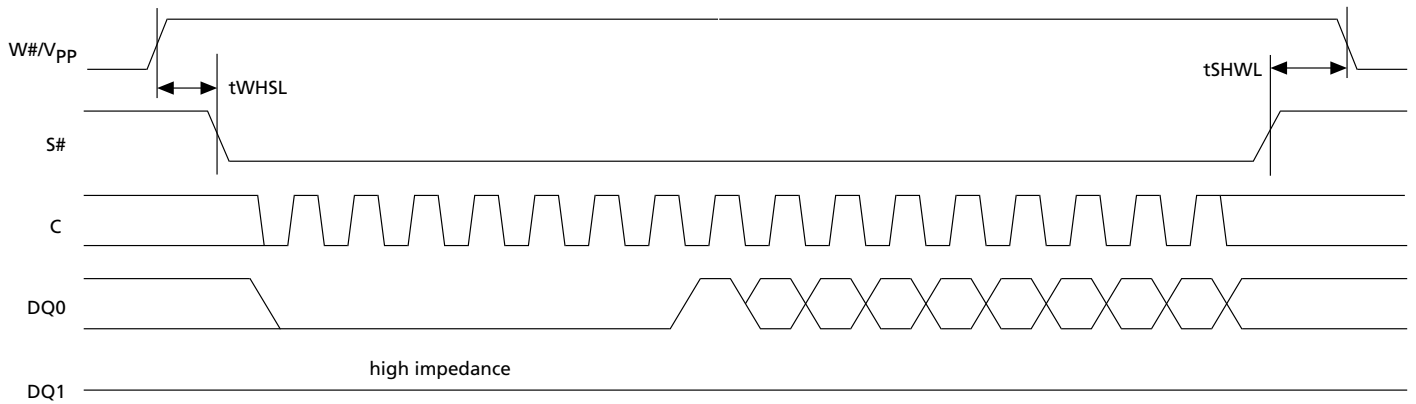

Figure 25: Hold Timing

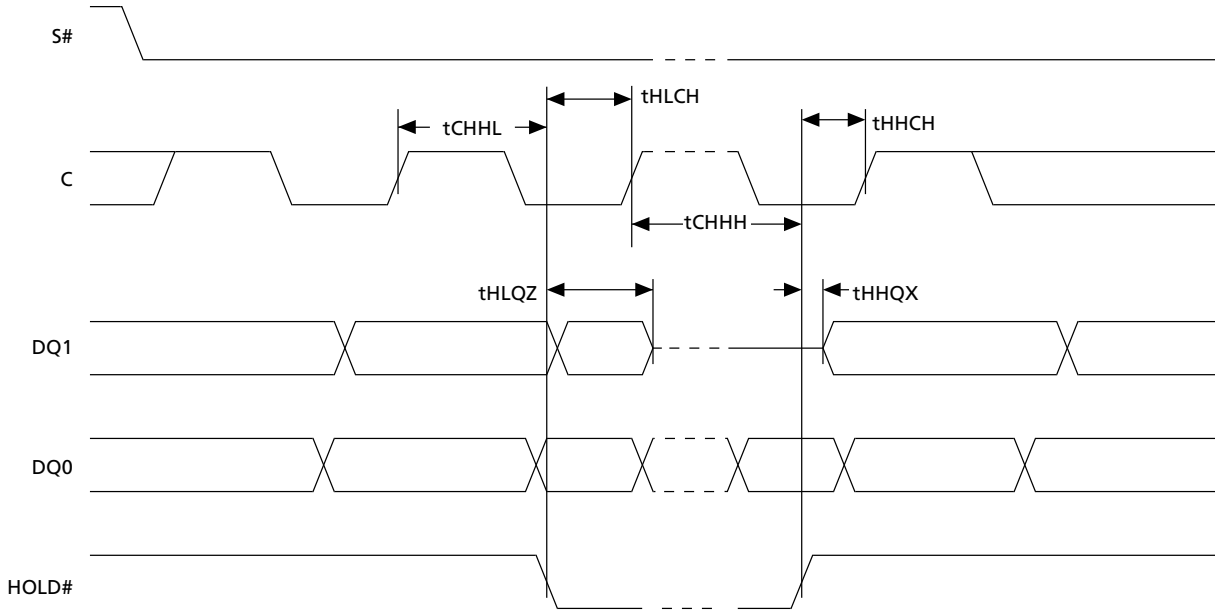
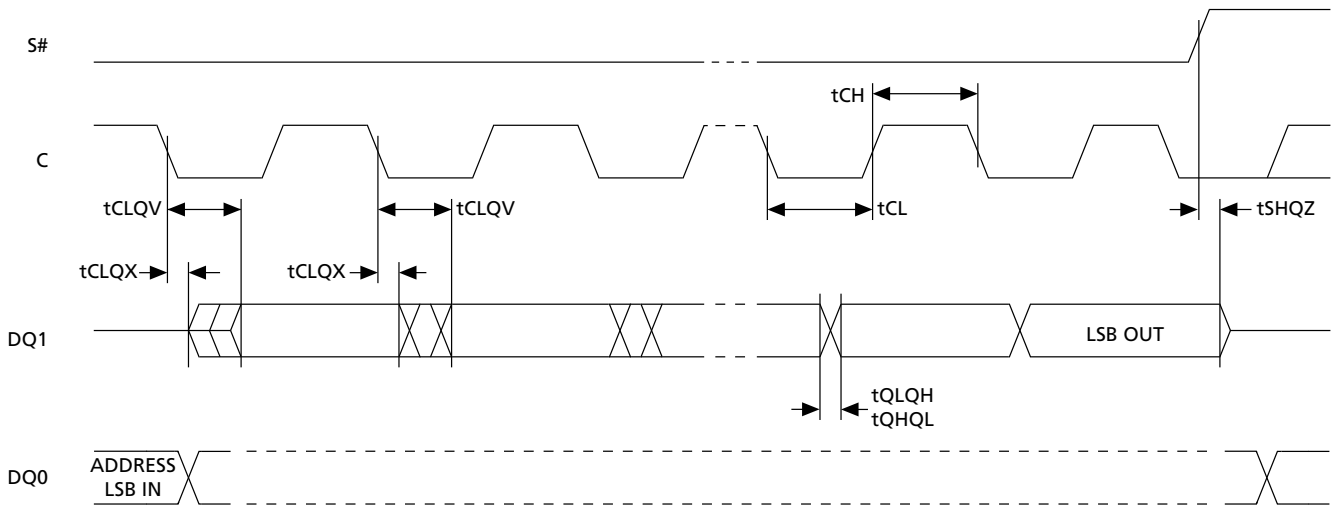
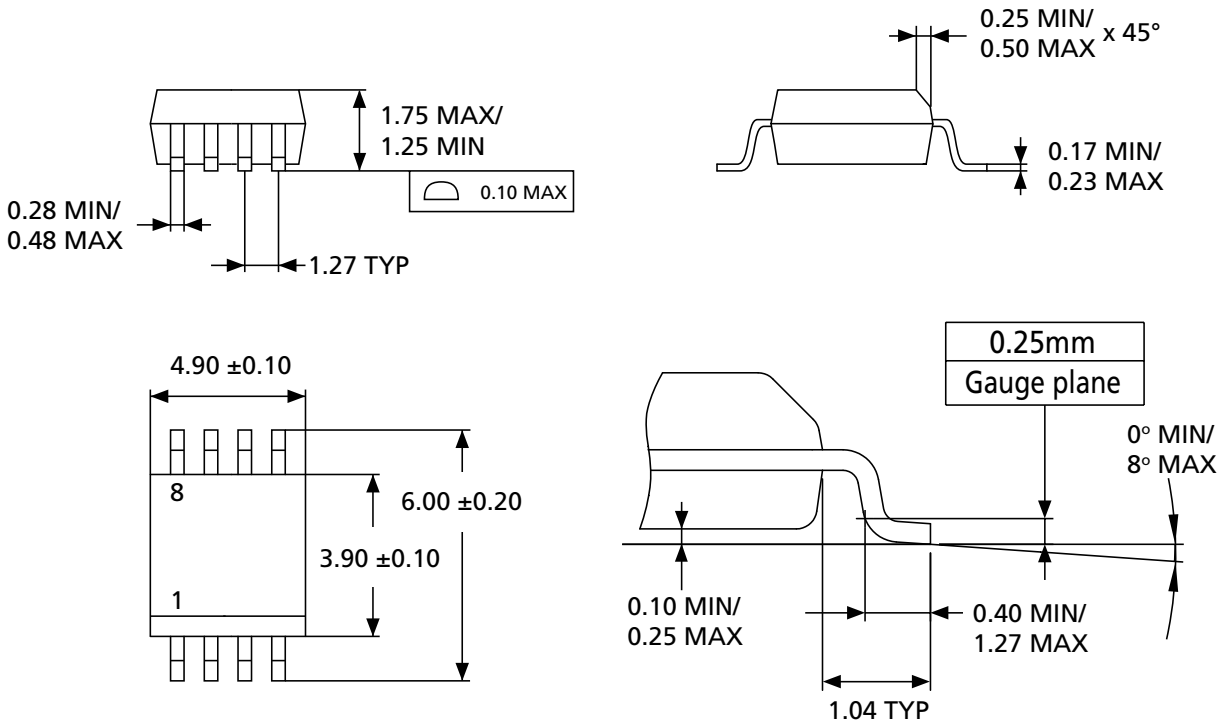

Figure 26: Output Timing



Package Information

Figure 27: SO8N 150mils Body Width



- Notes:
1. The 1 that appears in the top view of the package indicates the position of pin 1.
 2. Drawing is not to scale.

Figure 28: SO8W 208mils Body Width

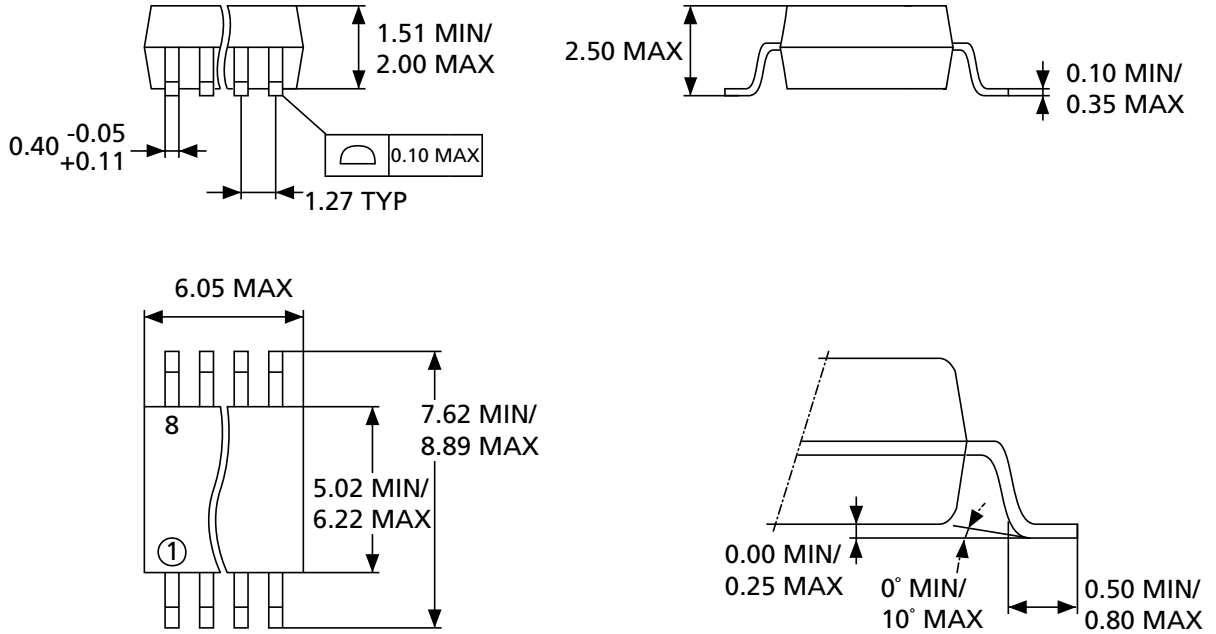

Note: 1. Drawing is not to scale.

Figure 29: DFN8 6mm x 5mm

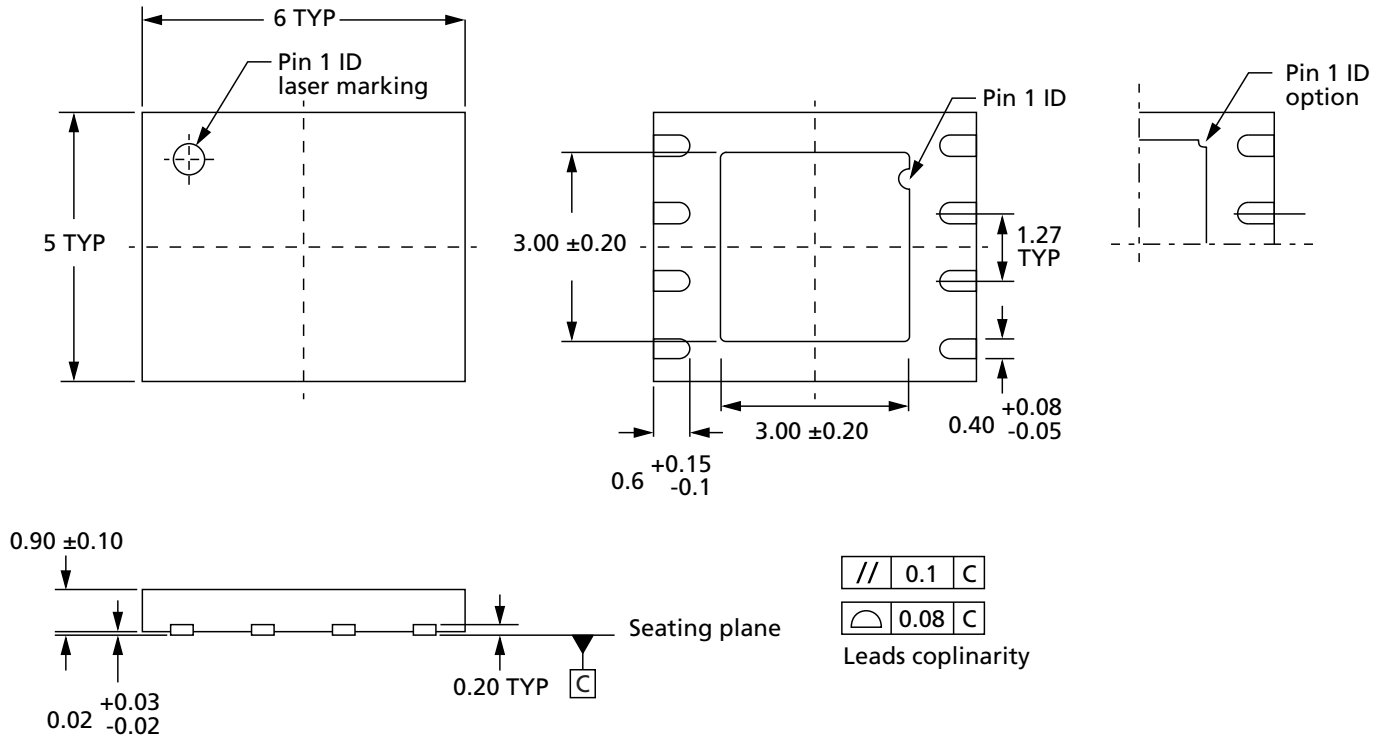

Note: 1. Drawing is not to scale.

Figure 30: VFDFPN8 (MLP8) 6mm x 5mm

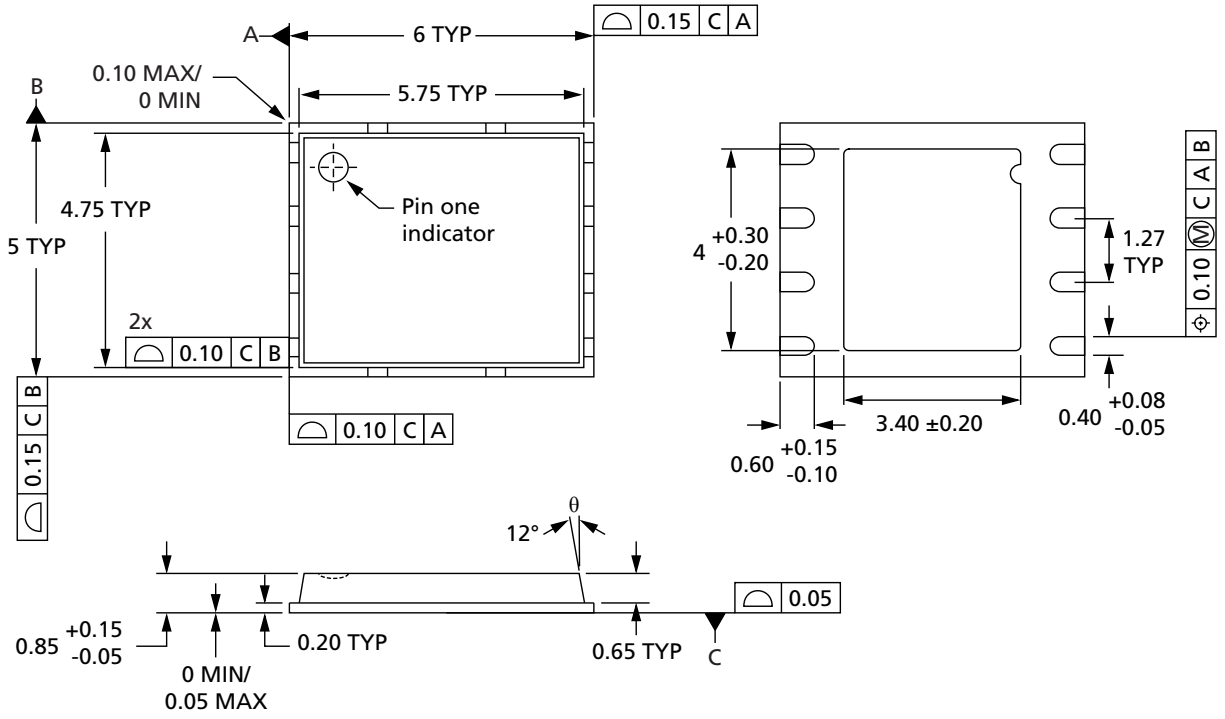

Note: 1. Drawing is not to scale.

Figure 31: UDFFPN8 (MLP8) 4mm x 3mm

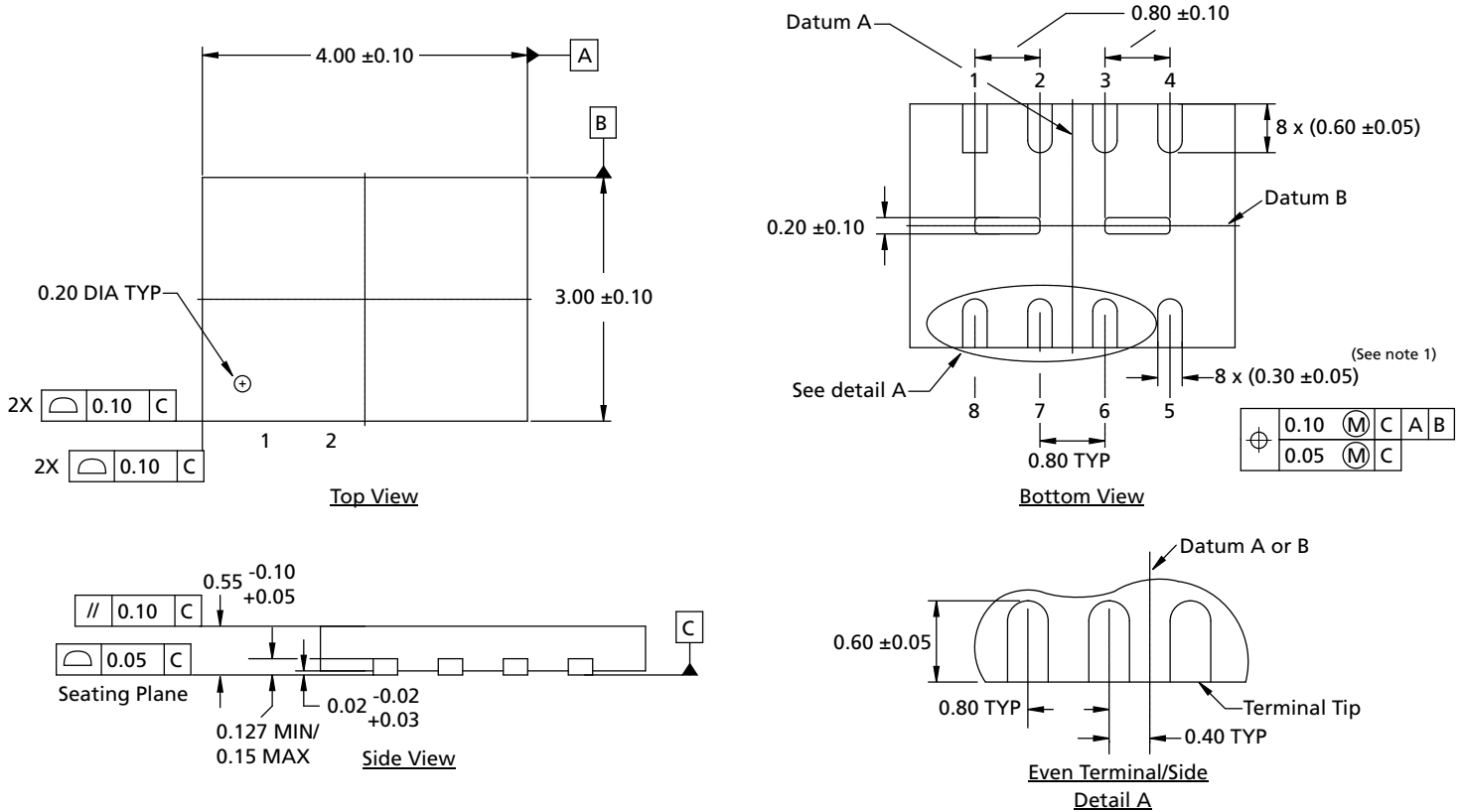

- Notes:
1. The dimension 0.30 ±0.05 applies to the metallic terminal and is measured between 0.15mm and 0.30mm from terminal tip. If the terminal has the optional radius on the other end of the terminal, the dimensions should not be measured in that radius area.
 2. Maximum package warping is 0.05mm; maximum allowable burrs is 0.076mm in all directions; bilateral coplanarity zone applies to the exposed heat sink slug as well as to the terminals.
 3. Drawing is not to scale.

Figure 32: UDFPN8 (MLP8) 2mm x 3mm

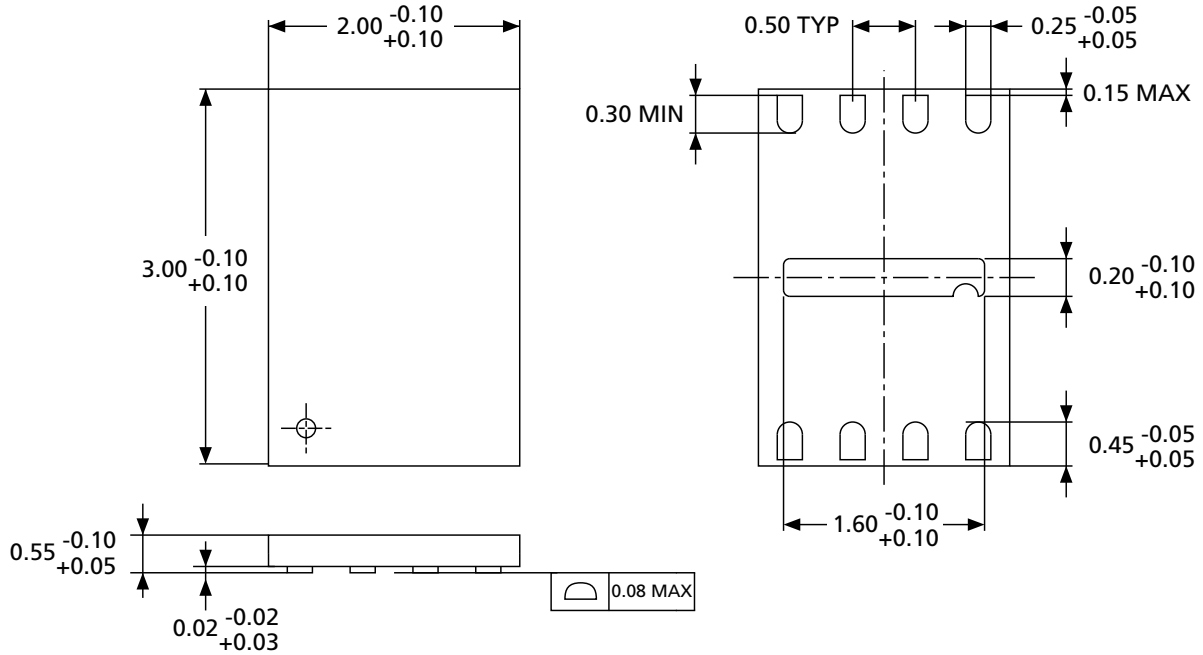

Note: 1. Drawing is not to scale.



Device Ordering Information

Standard Parts

For further information on line items not listed here or on any aspect of this device, contact your nearest representative.

Table 25: Part Number Example

Part Number Category									
Device Type	Density	Security Features	Operating Voltage	Package	Device Grade	Packing Option	Plating Technology	Lithography	Automotive Grade
M25P	40	–	V	MN	6	T	P	B	A

Table 26: Part Number Information Scheme

Part Number Category	Category Details	Notes
Device type	M25P = Serial Flash memory for code storage	
Density	40 = 4Mb (512Kb x 8)	
Security features	– = no extra security	1
	S = CFD programmed with UID	
Operating voltage	V = V _{CC} = 2.7V to 3.6V	2
Package	MN = SO8N (150 mils width)	3
	MW = SO8W (208 mils width)	
	MS = DFN8 6mm x 5mm (MLP8)	
	MP = VFDFPN8 6mm x 5mm (MLP8)	
	MB = UFDFPN8 2mm x 3mm (MLP8)	
	MC = UFDFPN8 4mm x 3mm (MLP8)	
Device Grade	6 = Industrial temperature range: –40°C to 85°C. Device tested with standard test flow.	4, 5
	3 = Automotive temperature range: –40°C to 125°C. Device tested with high reliability test flow.	
Packing Option	– = Standard packing tube	
	T = Tape and reel packing	
Plating technology	P or G = RoHS compliant	
Lithography	/X = 150nm technology	6
	/4 = 110nm technology, Catania diffusion plant	
	B = 110nm technology, Fab 2 diffusion plant	
Automotive Grade	A = Automotive: –40°C to 85°C part. Only with temperature grade 6. Device tested with high reliability test flow.	4
	– = Automotive: –40°C to 125°C. Only with temperature grade 3.	

- Notes: 1. Secure options are available upon customer request.
2. Maximum frequency device operation in the extended V_{cc} range (2.3V to 2.7V) is only on the 40 MHz device.



Micron M25P40 Serial Flash Embedded Memory Device Ordering Information

3. Exposed pad of 3mm x 3mm.
4. Micron recommends the use of the automotive grade device in the automotive environment, autograde 6 and grade 3.
5. Device grade 3 is available in an SO8 RoHS compliant package.
6. Identification marking /X denotes the automotive grade 3 device in 150nm technology. Identification marking B denotes the 110nm technology. For additional information contact your nearest Micron sales office.

Automotive Parts

For further information on line items not listed here or on any aspect of this device, contact your nearest representative.

Table 27: Part Number Example

Part Number Category									
Device Type	Density	Security Features	Operating Voltage	Package	Device Grade	Packing Option	Plating Technology	Lithography	Automotive Grade
M25P	40	–	V	MN	6	T	P	B	A

Table 28: Part Number Information Scheme

Part Number Category	Category Details	Notes
Device type	M25P = Serial Flash memory for code storage	
Density	40 = 4Mb (512Kb x 8)	
Security features	– = no extra security	
Operating voltage	V = V _{CC} = 2.7V to 3.6V	1
Package	MN = SO8N (150 mils width)	
	MB = UFQFPN8 2mm x 3mm (MLP8)	
Device Grade	6 = Industrial temperature range: –40°C to 85°C. Device tested with high reliability test flow.	
	3 = Automotive temperature range: –40°C to 125°C. Device tested with high reliability test flow.	2
Packing Option	– = Standard packing tube	
	T = Tape and reel packing	
Plating technology	P or G = RoHS compliant	
Lithography	B = 110nm technology, Fab 2 diffusion plant	
Automotive Grade	A = Automotive: –40°C to 85°C part. Only with temperature grade 6. Device tested with high reliability test flow.	2
	– = Automotive: –40°C to 125°C. Only with temperature grade 3.	

- Notes:
1. Maximum frequency device operation in the extended V_{cc} range (2.3V to 2.7V) is only on the 40 MHz device.
 2. Micron recommends the use of the automotive grade device in the automotive environment, autograde 6 and grade 3.

Revision History

Rev. X – 04/12

- Updated dimensions for MB package in the Part Number Information Scheme table in Device Ordering Information
- In Signal Names table, changed direction column for DQ0 and DQ1 to input and output respectively
- Changed the Write Disable Command Sequenced graphic
- Revised Write Status Register topic
- Revised Power-Up/Down and Supply Line Decoupling topic
- Revised DFN8 6mm x 5mm package figure

Rev. W – 03/12

- Updated dimensions for MC package in the Part Number Information Scheme table in Device Ordering Information

Rev. V – 02/12

- Corrected error in SO8N package drawing

Rev. U – 09/2011

- Applied Micron brand

Rev. 20.0 – 04/2010

- Corrected package nomenclature

Rev. 19.0 – 02/2010

- Added the following package information: UFDFPN8 (MLP8) 4mm x 3mm and UFDFPN8 (MLP8) 2mm x 3mm

Rev. 18.0 – 05/2009

- Revised cross references

Rev. 17.0 – 02/2009

- Table 8: Vwi Min (grade 3) = 1V versus 2.1V or (remove one row and grade indication)
- Table: Erase/Program Cycles = 100,000 cycles also for grade 3 (instead of 10,000)
- Table: Icc3 Operating Current (READ) change on test condition section as follows:
OLD: C = 0.1VCC / 0.9VCC at 40 MHz and 75 MHz, Q = open; NEW: C = 0.1VCC / 0.9VCC at 40 MHz, 50 MHz and 75 MHz, Q = open; OLD: C = 0.1VCC / 0.9VCC at 25 MHz, Q = open; NEW: C = 0.1VCC / 0.9VCC at 25 MHz and 33 MHz, Q = open
- Table: Icc3 Operating Current (READ) change on test condition section as follows:
OLD: C = 0.1VCC / 0.9VCC at 25 MHz, Q = open; NEW: C = 0.1VCC / 0.9VCC at 25 MHz and 75 MHz, Q = open; OLD: C = 0.1VCC / 0.9VCC at 20 MHz, Q = open; NEW: C = 0.1VCC / 0.9VCC at 20 MHz and 33 MHz, Q = open

- Table 15: Valid also for grade 3: OLD: Instruction times, process technology 110nm (device grade 6); NEW: Instruction times, process technology 110nm
- Table 16: Valid also for grade 3: OLD: Instruction times, process technology 150nm (device grade 6); NEW: Instruction times, process technology 150nm
- Table 17: Deleted
- Table 19: Added the following to the table head: "Identified with device belonging to X technology version;" changed tRES1 = 30us and tRES2 = 30us (removed 3us and 1.8us and note 5)

Rev. 16.0 – 10/2008

- Changed frequency up to 75 MHz (only in the standard Vcc range)
- Added new packages
- Added UID/CFD protection
- Extended Vcc range to 2.3V

Rev. 15.0 – 12/2007

- Applied Numonyx brand

Rev. 14.0 – 06/2007

- Modified the note below Table 13
- Changed test condition for ICC3 in Table 14
- Changed clock frequency, from 20 to 25 MHz, in Table 20 and Table 21

Rev. 13.0 – 05/2007

- 40 MHz operation added (see Table: AC Characteristics (*40 MHz operation, device grade 6, VCC min = 2.3V)
- Removed the note below Table 10
- Removed Table: AC Characteristics (33 MHz operation, device grade 6, VCCmin =2.3V)

Rev. 12.0 – 01/2007

- VCC voltage range from W17 2007 is extended to 2.3V to 3.6V
- Added Table: AC Characteristics (33 MHz operation, device grade 6, VCCmin =2.3V)
- AC characteristics at 40 MHz removed

Rev. 11.0 – 12/2006

- Hardware write protection feature added to cover; small text changes to cover
- Added sections on VCC supply voltage and VSS ground
- Revised Figure: Bus Master and Memory Devices on the SPI Bus
- WIP bit behavior specified at power-up in Power-Up and Power-Down section
- Revised Table: Absolute Maximum Ratings and VIO Maximum
- VFQFPN8 package specifications updated

Rev. 10.0 – 06/2006

- tRES1 and tRES2 parameter timings changed for devices produced with the /X process technology
- SO8 Narrow package specifications updated

Rev. 9.0 – 04/2006

- Data contained in Table 12 and Table 19 is no longer preliminary
- Modified Figure: Bus Master and memory devices on the SPI bus
- 40 MHz frequency condition modified for ICC3 in Table: DC Characteristics (device grade 3)
- Condition changed for the data retention parameter in Table: Data Retention and Endurance
- VWI parameter for device grade 3 added to Table: Power-up Timing and VWI Threshold
- SO8 package specifications updated
- /X process added to Table: Ordering Information Scheme

Rev. 8.0 – 12/2005

- Note 2 added below Figure 26 and note 3 added below Figure 29
- tRES1 and tRES2 modified in Table 20: AC Characteristics (50 MHz operation, device grade 6, VCCmin = 2.7V)
- Read Identification (RDID) added. Titles of Figure 29 and Table 26 corrected.

Rev. 7.0 – 10/2005

- 50 MHz operation added
- All packages are RoHS compliant. Blank option removed from under plating technology in Table: Ordering Information Scheme.
- MLP package renamed as VFQFPN, silhouette and package mechanical drawing updated

Rev. 6.0 – 08/2005

- Updated Page Program commands under heading, "Page Programming, Page Program, Instruction Times, Process Technology 110nm"

Rev. 5.0 – 01/2005

- Minor text changes
- Notes 2 and 3 removed from Table: Ordering Information Scheme
- End timing line of tSHQZ modified in Figure: Output Timing

Rev. 4.0 – 08/2004

- Device grade information clarified
- Data-retention measurement temperature corrected
- Details of how to find the date of marking added



Rev. 3.0 – 03/2004

- Automotive range added
- Soldering temperature information clarified for RoHS compliant devices

Rev. 2.0 – 11/2003

- Table of contents, warning about exposed paddle on MLP8, and Pb-free options added
- Change of naming for VDFPN8 package
- 40 MHz AC Characteristics table included as well as 25 MHz. ICC3 (max), tSE (TYP) and tBE (TYP) values improved.

Rev. 1.0 – 06/2003

- Initial data sheet release

8000 S. Federal Way, P.O. Box 6, Boise, ID 83707-0006, Tel: 208-368-3900
www.micron.com/productsupport Customer Comment Line: 800-932-4992
Micron and the Micron logo are trademarks of Micron Technology, Inc.
All other trademarks are the property of their respective owners.

This data sheet contains minimum and maximum limits specified over the power supply and temperature range set forth herein. Although considered final, these specifications are subject to change, as further product development and data characterization sometimes occur.