

Basic Switch

X

General Purpose Basic Switch

- Direct current switch with built-in magnetic blowout
- Incorporates a small permanent magnet in the contact mechanism to deflect the arc to effectively extinguish it
- Ideal for switching DC circuits
- Wide variety of actuators for a wide scope of applications
- Same shape as OMRON Basic Switch Model Z



Ordering Information

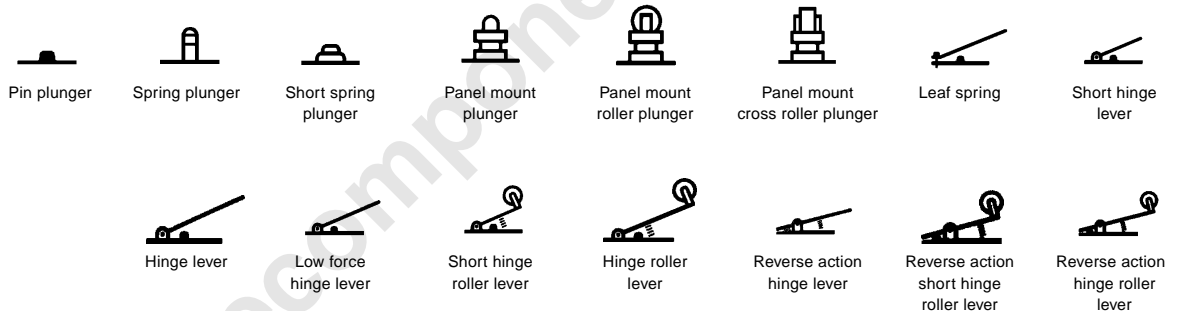

Actuator	Part Number	
	Solder Terminal	Screw Terminal
Pin plunger	X-10G	X-10G-B
Spring plunger	X-10GS	X-10GS-B
Short spring plunger	X-10GD	X-10GD-B
Panel mount plunger	X-10GQ	X-10GQ-B
Panel mount roller plunger	X-10GQ22	X-10GQ22-B
Panel mount cross roller plunger	X-10GQ21	X-10GQ21-B
Leaf spring	X-10GL	X-10GL-B
Short hinge lever	X-10GW21	X-10GW21-B
Hinge lever	X-10GW	X-10GW-B
Low force hinge lever	X-10GW4	X-10GW4-B
Short hinge roller lever	X-10GW22	X-10GW22-B
Hinge roller lever	X-10GW2	X-10GW2-B
Reverse action hinge lever	X-10GM	X-10GM-B
Reverse action short hinge roller lever	X-10GM22	X-10GM22-B
Reverse action hinge roller lever	X-10GM2	X-10GM2-B

Note: 1. With reverse action type actuators, the plunger is always held down by the action of the compression coil spring, and operates the switch when released from the down position by the action of the lever.
 Since the plunger is held down with the actuator in the free state, the switch has excellent resistance to vibration and shock.
 2. Models conforming to UL and CSA are so marked. However, those conforming to SEV are not marked. The mark "SEV" can be inscribed on request (in this case, however, neither "UL" nor "CSA" can be inscribed).

X **OMRON** X

CONTACT FORM

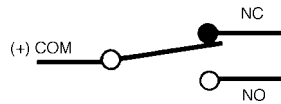

Specifications

Rated voltage	Non-inductive load (A)			Inductive load (A)			
	Resistive load	Lamp load		Inductive load		Motor load	
		NC	NO	NC	NO	NC	NO
8 VDC	15	3	3	15	15	10	10
14 VDC	15	3	3	15	10	10	10
30 VDC	15	3	3	10	10	10	6
125 VDC	10	3	1.5	7.5	6	6	4
250 VDC	3	1.5	0.75	2	1.5	2	1
Inrush current	NC: 30 A max. NO: 15 A max.		NC: 30 A max. NO: 15 A max.				

- Note:
1. Inductive load has a power factor of 0.4 min. (AC) and a time constant of 7 milliseconds max. (DC).
 2. Lamp load has an inrush current of 10 times the steady-state current, while motor load has an inrush of 6 times the steady-state current.
 3. The UL and CSA listed marks are stamped on all standard products. The SEV approval mark may be stamped on request. In such a case, however, the UL and CSA markings will not be provided on the requested product.

Characteristics

Operating speed		0.1 mm to 1 m/second (0.004 to 39.4 in/second) at pin plunger
Operating frequency	Mechanical	240 operations per minute
	Electrical	20 operations per minute
Contact resistance		15 mΩ max. (initial)
Insulation resistance		100 MΩ min. (at 500 VDC)
Dielectric strength (VAC)		1,500 VAC, 50/60 Hz for 1 minute between non-continuous terminals, between each terminal and noncurrent-carrying part and between each terminal and ground
Vibration	Malfunction durability	10 to 55 Hz, 1.5 mm double amplitude
Shock	Mechanical durability	1,000 m/s ² min. (approx. 100 g)
	Malfunction durability	300 m/s ² min. (approx. 30 g)
Ambient temperature	Operating	-25° to 80°C (with no icing)
Humidity		35% to 85% RH
Service life	Mechanical	1,000,000 operations minimum (at rated OT value)
	Electrical	100,000 operations minimum (under rated load)
Weight		Approx. 27 to 63 g

Note: Data shown are of initial value.

X OMRON **X**

CHARACTERISTIC DATA

Mechanical service life

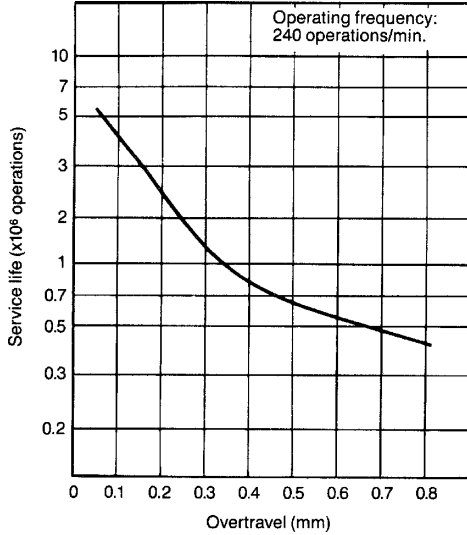

Electrical service life

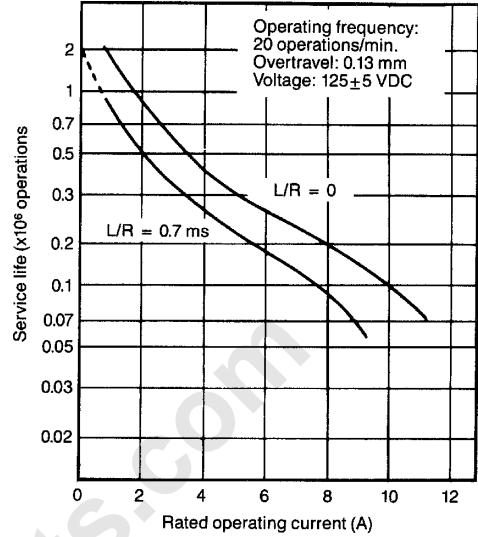

Dimensions

Unit: mm (inch)

X-10G-B

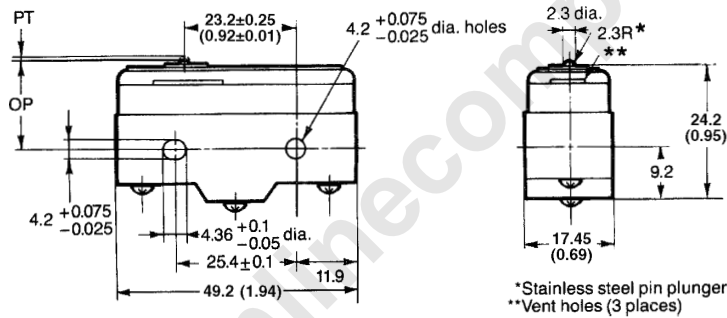

Operating characteristics	X-10G-B
OF max.	510 g
RF min.	114 g
PT max.	0.9 mm (0.04 in)
OT min.	0.13 mm (0.01 in)
MD max.	0.18 mm (0.01 in)
OP	15.9±0.4 mm (0.63±0.02 in)

X-10GS-B

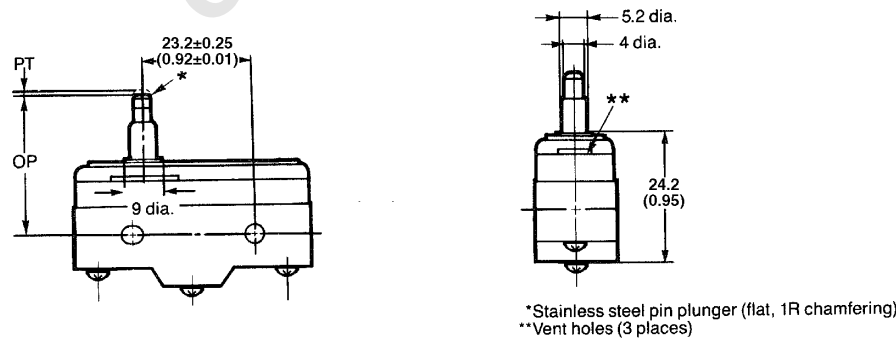

Operating characteristics	X-10GS-B
OF max.	510 g
RF min.	114 g
PT max.	0.9 mm (0.04 in)
OT min.	1.6 mm (0.06 in)
MD max.	0.18 mm (0.01 in)
OP	28.2±0.5 mm (1.11±0.02 in)

Note: 1. Unless otherwise specified, a tolerance of ± 0.4 mm applies to all dimensions.

2. All drawings show the switches with screw terminals. For solder terminals, remove the "-B" from the end of the part number.

X **OMRON** X

Unit: mm (inch)

X-10GD-B

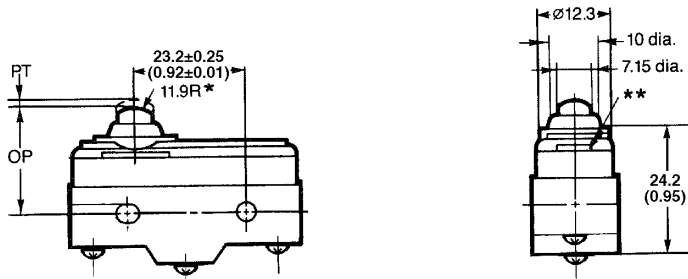

* Plated iron plunger
** Three vent holes

Operating characteristics	X-10GD-B
OF max.	510 g
RF min.	114 g
PT max.	0.9 mm (0.04 in)
OT min.	1.6 mm (0.06 in)
MD max.	0.18 mm (0.01 in)
OP	21.2±0.5 mm (0.83±0.02 in)

X-10GQ-B

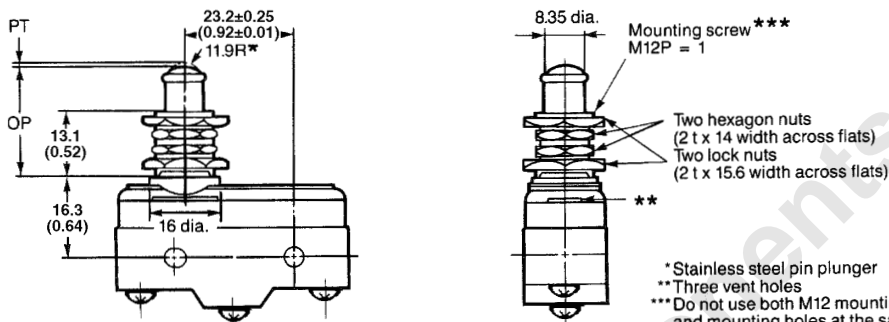

* Stainless steel pin plunger
** Three vent holes
*** Do not use both M12 mounting screw and mounting holes at the same time.

Operating characteristics	X-10GQ-B
OF max.	510 g
RF min.	114 g
PT max.	0.9 mm (0.04 in)
OT min.	5.5 mm (0.22 in)
MD max.	0.18 mm (0.01 in)
OP	21.2±0.8 mm (0.83±0.03 in)

X-10GQ22-B

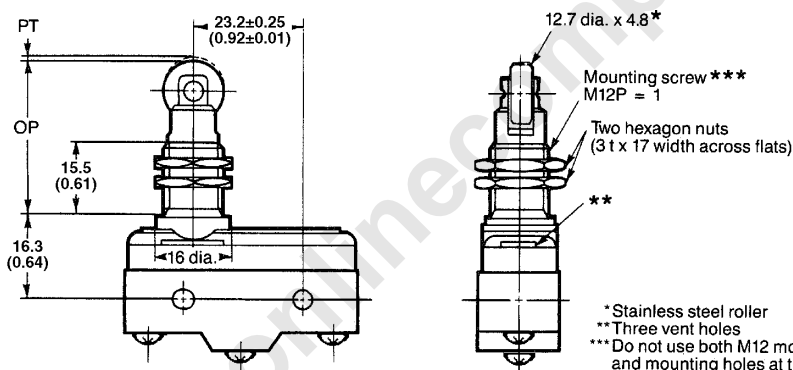

* Stainless steel roller
** Three vent holes
*** Do not use both M12 mounting screw and mounting holes at the same time.

Operating characteristics	X-10GQ22-B
OF max.	510 g
RF min.	114 g
PT max.	0.9 mm (0.04 in)
OT min.	3.6 mm (0.14 in)
MD max.	0.18 mm (0.01 in)
OP	33.4±1.2 mm (1.31±0.05 in)

X-10GQ21-B

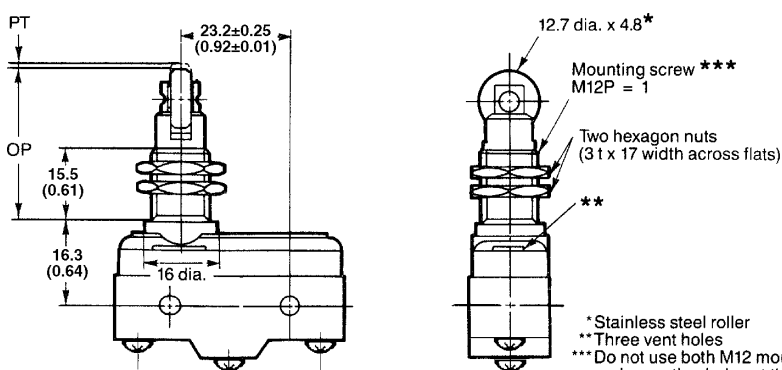

* Stainless steel roller
** Three vent holes
*** Do not use both M12 mounting screw and mounting holes at the same time.

Operating characteristics	X-10GQ21-B
OF max.	510 g
RF min.	114 g
PT max.	0.9 mm (0.04 in)
OT min.	3.6 mm (0.14 in)
MD max.	0.18 mm (0.01 in)
OP	33.4±1.2 mm (1.31±0.05 in)

Note: 1. Unless otherwise specified, a tolerance of ± 0.4 mm applies to all dimensions.

2. All drawings show the switches with screw terminals. For solder terminals, remove the "-B" from the end of the part number.

X **OMRON** X

X-10GL-B

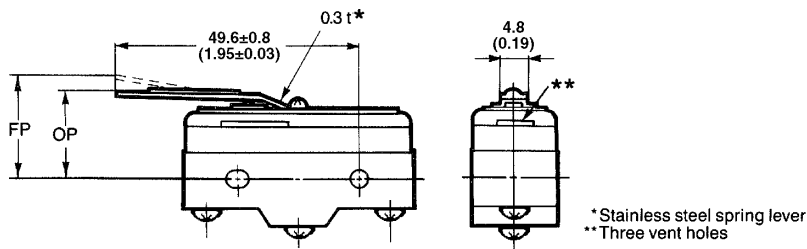

Operating characteristics	X-10GL-B
OF max.	200 g
RF min.	14 g
PT max.	5.4 mm* (0.21 in)
OT min.	1.6 mm** (0.06 in)
MD max.	2.3 mm (0.09 in)
FP max.	22.1 mm (0.87 in)
OP	17.4±0.8 mm (0.69±0.03 in)

* Reference value
** Be sure to use the switch at the rated OT value of 1.6 mm.

X-10GW21-B

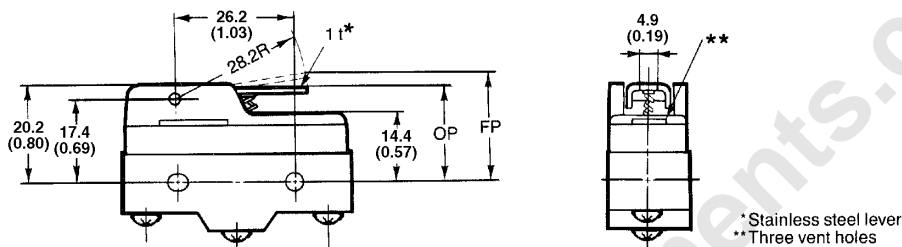

Operating characteristics	X-10GW21-B
OF max.	250 g
RF min.	32 g
PT max.	5.6 mm* (0.22 in)
OT min.	2.1 mm (0.08 in)
MD max.	1.7 mm (0.07 in)
FP max.	25.5 mm (1.00 in)
OP	20.7±0.8 mm (0.81±0.03 in)

* Reference value

X-10GW-B

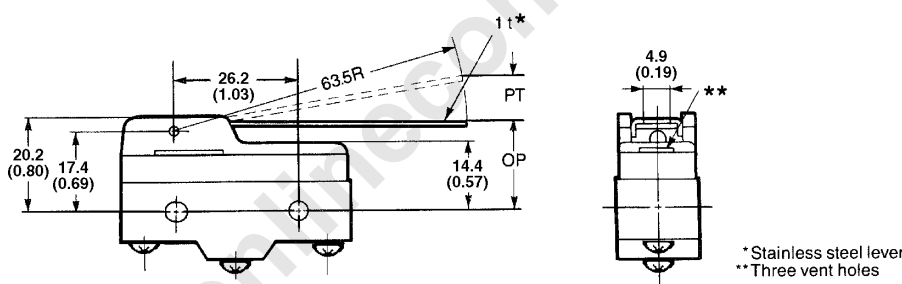

Operating characteristics	X-10GW-B
OF max.	110 g
RF min.	14 g
PT max.	14.3 mm* (0.56 in)
OT min.	4.8 mm (0.19 in)
MD max.	3.9 mm (0.15 in)
FP max.	34.6 mm (1.36 in)
OP	21.1±0.8 mm (0.83±0.03 in)

* Reference value

X-10GW4-B

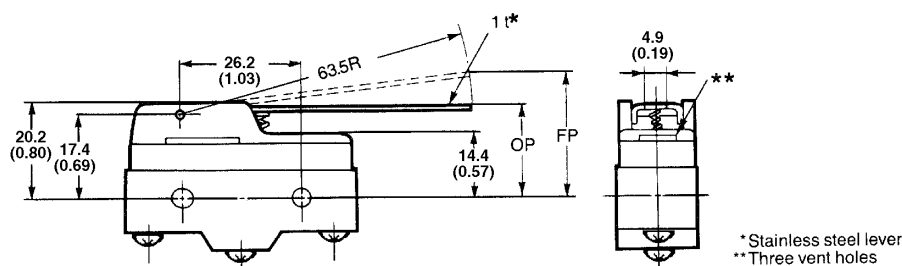

Operating characteristics	X-10GW4-B
OF max.	25 g
RF min.	5 g
PT max.	14.3 mm (0.56 in)
OT min.	4.8 mm (0.19 in)
MD max.	3.9 mm (0.15 in.)
OP	21.1±0.8 mm (0.83±0.03 in)

Note: 1. Unless otherwise specified, a tolerance of ± 0.4 mm applies to all dimensions.
2. All drawings show the switches with screw terminals. For solder terminals, remove the "-B" from the end of the part number.

X **OMRON** X

Unit: mm (inch)

X-10GW22-B

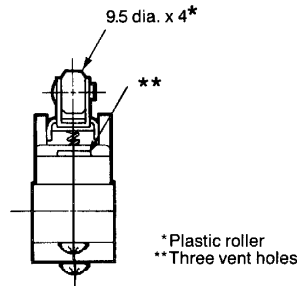
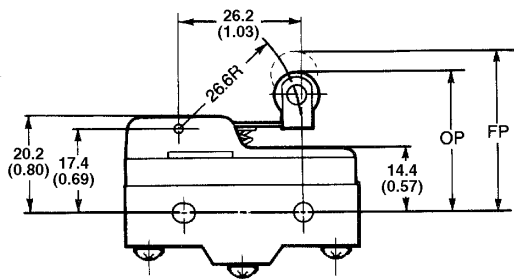

Operating characteristics	X-10GW22-B
OF max.	220 g
RF min.	35 g
PT max.	5.7 mm* (0.22 in)
OT min.	2.4 mm (0.09 in)
MD max.	1.7 mm (0.07 in)
FP max.	37.1 mm (1.46 in)
OP	32.2±0.8 mm (1.27±0.03 in)

* Reference value

X-10GW2-B

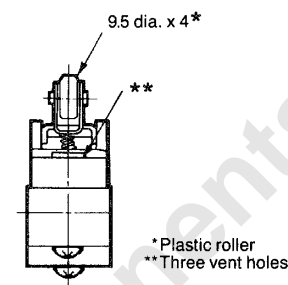
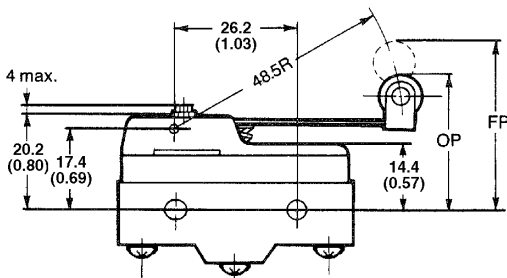

Operating characteristics	X-10GW2-B
OF max.	145 g
RF min.	21 g
PT max.	9.1 mm* (0.35 in)
OT min.	4 mm (0.16 in)
MD max.	3 mm (0.12 in)
FP max.	40.5 mm (1.59 in)
OP	32.2±0.8 mm (1.27±0.03 in)

* Reference value

X-10GM-B

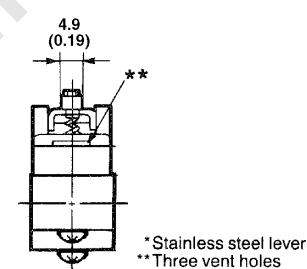
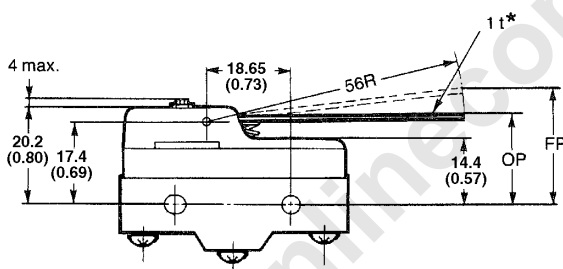

Operating characteristics	X-10GM-B
OF max.	220 g
RF min.	25 g
PT max.	6.5 mm* (0.26 in)
OT min.	5.5 mm (0.22 in)
MD max.	2.1 mm (0.08 in)
FP max.	26.8 mm (1.06 in)
OP	21.1±0.8 mm (0.83±0.03 in)

* Reference value

X-10GM22-B

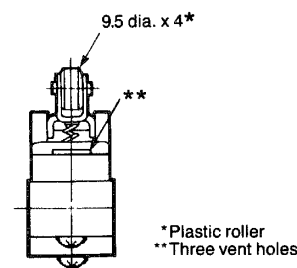
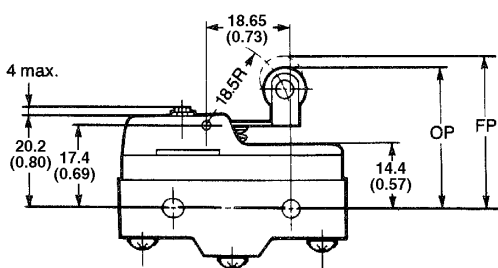

Operating characteristics	X-10GM22-B
OF max.	700 g
RF min.	150 g
PT max.	4.7 mm* (0.19 in)
OT min.	2 mm (0.08 in)
MD max.	0.75 mm (0.03 in)
FP max.	36.1 mm (1.42 in)
OP	32.2±0.8 mm (1.27±0.03 in)

* Reference value

Note: 1. Unless otherwise specified, a tolerance of ± 0.4 mm applies to all dimensions.
2. All drawings show the switches with screw terminals. For solder terminals, remove the "-B" from the end of the part number.

X **OMRON** X

X-10GM2-B

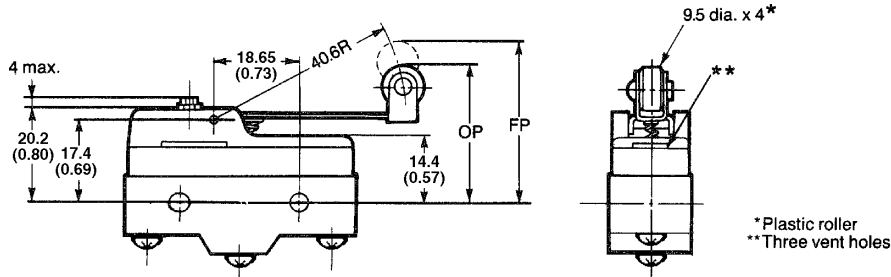

Operating characteristics	X-10GM2-B
OF max.	320 g
RF min.	50 g
PT max.	6 mm* (0.24 in)
OT min.	4 mm (0.16 in)
MD max.	1.5 mm (0.06 in)
FP max.	37.4 mm (1.47 in)
OP	32.2±0.8 mm (1.27±0.03 in)

* Reference value

Note: 1. Unless otherwise specified, a tolerance of ± 0.4 mm applies to all dimensions.
2. All drawings show the switches with screw terminals. For solder terminals, remove the "-B" from the end of the part number.

■ **MOUNTING HOLES**

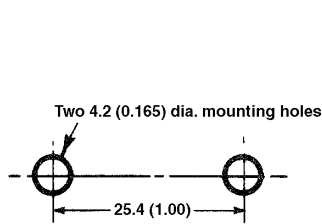

Panel cutout
Panel mount pin plunger

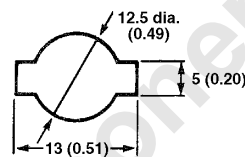

Panel mount roller
pin plunger

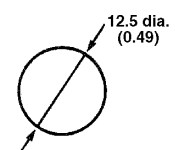

■ **ACCESSORIES**

Unit: mm (inch)
Order separately

Hinge lever
XAA-1



Hinge roller lever
XAA-2



Panel mount plunger
Short ZAQ-3
Medium ZAQ-2
Long ZAQ-1



Hinge lever
XAA-1

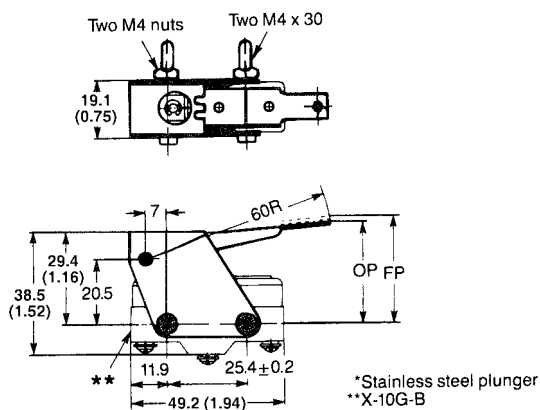

Operating characteristics	XAA-1 with X-10G
OF max.	500 g
RF min.	170 g
RT max.	7.2 mm* (0.28 in)
OT min.	12.7 mm (0.50 in)
MD max.	3.3 mm (0.13 in)
FP	32.9±1.6 mm (1.30±0.06 in)
OP	28.9±1.6 mm (1.14±0.06 in)

* Reference value

Note: 1. Unless otherwise specified, a tolerance of ± 0.8 mm applies to all dimensions.

OMRON

■ **ACCESSORIES, continued**

Unit: mm (inch)

**Hinge roller lever
XAA-2**

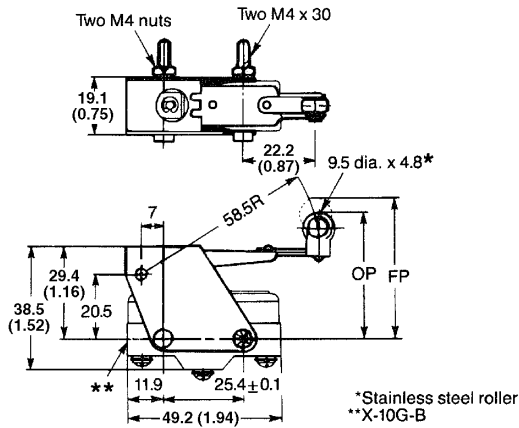

Operating characteristics	XAA-2 with X-10G
OF max.	500 g
RF min.	170 g
RT max.	7.3 mm* (0.29 in)
OT min.	12.7 mm (0.50 in)
MD max.	3.3 mm (0.13 in)
FP	44.5±1.6 mm (1.75±0.06 in)
OP	40.4±1.6 mm (1.59±0.06 in)

* Reference value

**Panel mount plunger
ZAQ-3**

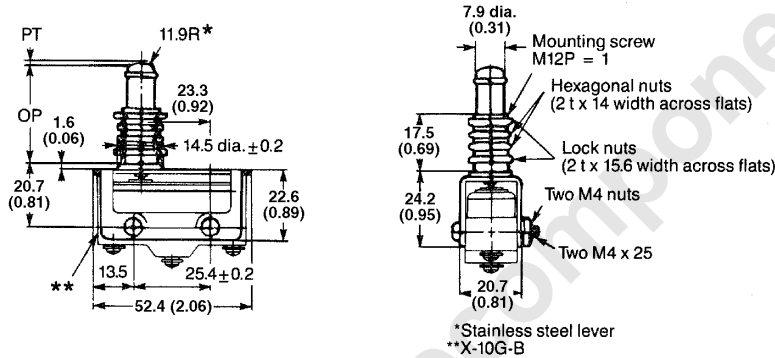

Operating characteristics	ZAQ-3 with X-10G
OF max.	550 g
RF min.	144 g
RT max.	1 mm (0.04 in)
OT min.	4.5 mm (0.18 in)
MD max.	0.2 mm (0.01 in)
OP	27.8±1.5 mm (1.09±0.06 in)

**Panel mount plunger
ZAQ-2**

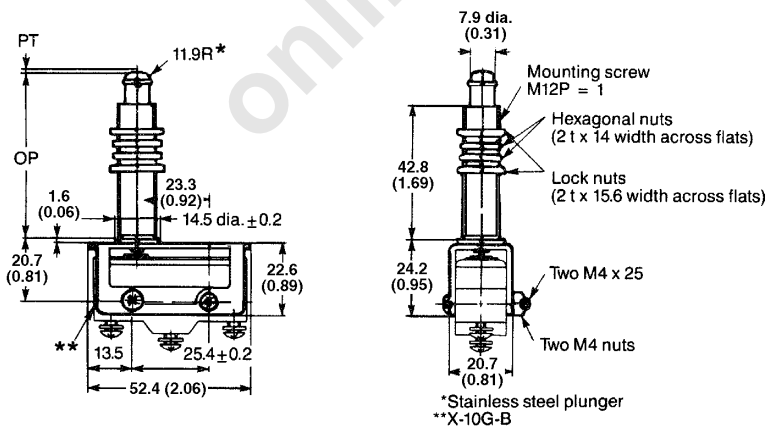

Operating characteristics	ZAQ-2 with X-10G
OF max.	550 g
RF min.	144 g
RT max.	1 mm (0.04 in)
OT min.	4.5 mm (0.18 in)
MD max.	0.2 mm (0.01 in)
OP	53.2±1.5 mm (2.09±0.06 in)

Note: 1. Unless otherwise specified, a tolerance of ± 0.8 mm applies to all dimensions.

X OMRON **X**

**Panel mount plunger
ZAQ-1**

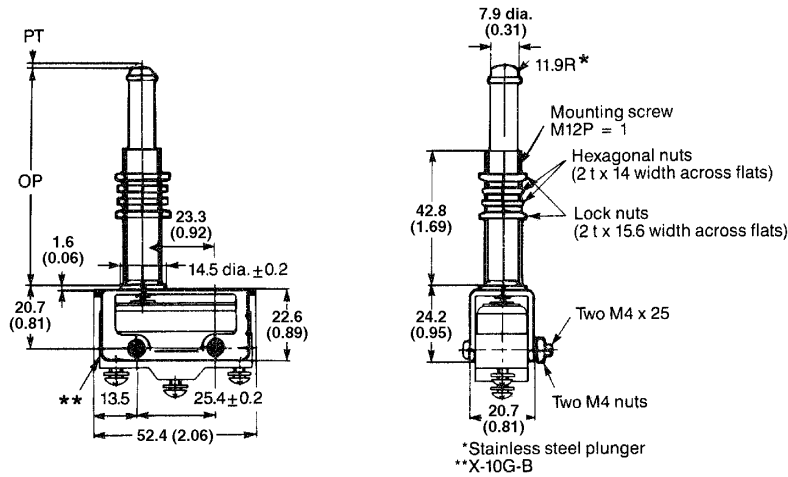

Operating characteristics	ZAQ-1 with X-10G
OF max.	550 g
RF min.	144 g
RT max.	1 mm (0.04 in)
OT min.	20.4 mm (0.80 in)
MD max.	0.2 mm (0.01 in)
OP	69.1±1.5 mm (2.72±0.06 in)

Note: 1. Unless otherwise specified, a tolerance of ± 0.8 mm applies to all dimensions.

■ TERMINALS

Solder terminal (blank)

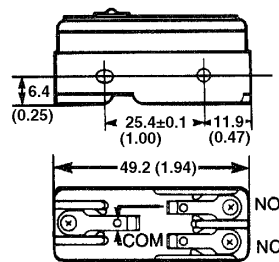

Screw terminal (B)

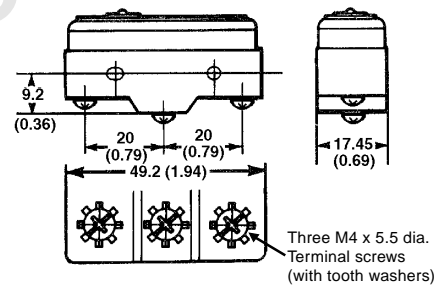

■ APPROVALS

UL (File No. E41515)/CSA (File No. LR21642)/LLOYD (File No. KOB-412171)/SEV (File No. D3, 21/115a)

Type	Ratings
X-10 series	10 A, 125 VDC 3 A, 250 VDC

Note: The rated values approved by each of the safety standards (e.g. UL, CSA) may be different from the performance characteristics individually defined in this catalog.

Precautions

■ HANDLING

Use M4 screws in combination with plane washers or spring washers to securely mount the switch. Tighten the screws at a torque of 12 to 15 kg-cm.

When mounting the panel-mount model (the one having a suffix "-Q" in its model number) on a panel, tighten the hexagon nut of the actuator at a torque of 50 kg-cm maximum.

To solder the lead to the terminal, apply a soldering iron rated at 60 W max. quickly (within 5 seconds) with the actuator at the free position.

Note that applying a soldering iron for too long a time or using one that is rated at more than 60 W may degrade the switch characteristics.

Since the arc quenching capability of the magnetic blowout is governed by the amount of current to be switched, the arching time may not be uniform in the event of highly inductive loads with small currents. When the time constant L/R of 0.6 to 1.2 A loads exceeds 7 milliseconds, use of an arc suppressor circuit is required. As an example of arc suppressor circuit consisting of resistance R and capacitance C in series, obtain the optimum condition by combining R and C within the range of $R = 5$ to 100Ω and $C = 0.05$ to $1 \mu\text{F}$. Then connect the RC circuit between the switch terminals or load terminals so as to produce satisfactory results. (Consult OMRON for further details.)

Since the switch incorporates a permanent magnet, attention must be paid to the following points:

1. Avoid mounting the switch directly onto a magnetic substance.
2. Do not subject the switch to severe shocks.
3. Avoid placing the switch in a strong magnetic field.
4. Be sure to prevent iron dust or iron chips from adhering to the built-in magnet or the magnetic blowout function of the switch will be adversely affected.
5. do not apply thermal shock to the switch, or the magnetic flux will be diminished.

■ PANEL-MOUNT MODEL (X-10GQ□)

To side-mount the panel-mount switch to the panel with screws, remove the hexagon nut from the actuator. In this case, exercise care that no impulsive force is applied to the actuator. Pay special attention to the impulsive force when the switch is to be released because such force may damage the switch.

Too large a dog angle and too fast operating speed may damage the switch when the switch is side-mounted on the panel.

Too fast operating speed and too long overtravel of the roller plunger switch may result in damage to the switch.

OMRON

OMRON ELECTRONICS, INC.

One East Commerce Drive
Schaumburg, IL 60173
1-800-55-OMRON

OMRON CANADA, INC.

885 Milner Avenue
Scarborough, Ontario M1B 5V8
416-286-6465