

# APPROVAL SHEET

**WW12P, WW08P, WW06P**

**±1%, ±5% 20mΩ~976mΩ**

High Power Low Ohmic Chip Resistors

Size 1206 1/2W; 0805 1/3W ; 0603 1/4W



\*Contents in this sheet are subject to change without prior notice.

## FEATURE

1. Small size and light weight
2. High reliability and stability
3. Reduced size of final equipment
4. High precision
5. RoHS compliant and Lead free products

## APPLICATION

- High accuracy dc-power supply
- Digital multi-meter
- Telecommunication
- Computer
- Automotive industry
- Medical and military equipment

## DESCRIPTION

The resistors are constructed in a high grade ceramic body (aluminum oxide). Internal metal electrodes are added at each end and connected by a resistive paste that is applied to the top surface of the substrate. The composition of the paste is adjusted to give the approximate resistance required and the value is trimmed to nominated value within tolerance which controlled by laser trimming of this resistive layer.

The resistive layer is covered with a protective coat. Finally, the two external end terminations are added. For ease of soldering the outer layer of these end terminations is Tin (lead free) alloy.

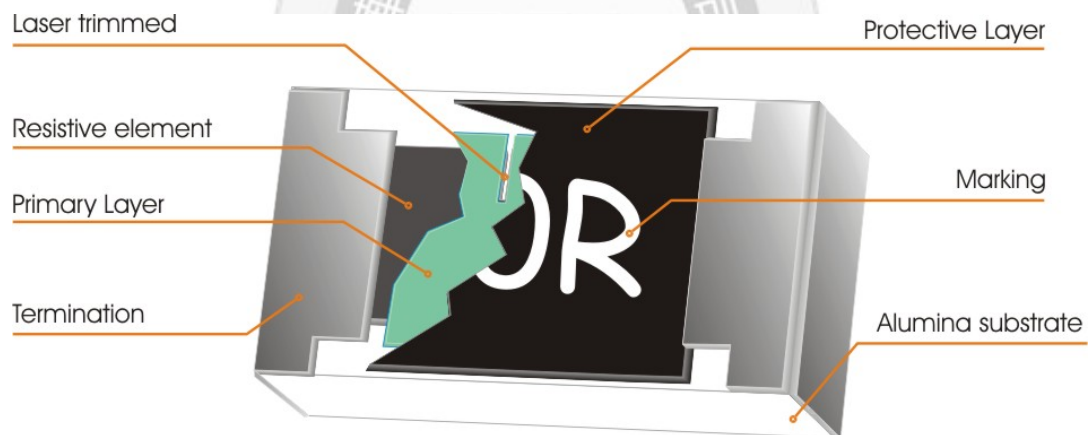

Fig 1. Construction of Chip-R

## QUICK REFERENCE DATA

Item	General Specification		
Series No.	WW08P	WW06P	WW12P
Size code	0805 (2012)	0603(1608)	1206
Resistance Tolerance	±1%, ±5%		
Resistance Range	0.047Ω~0.976Ω(E24 series)		0.020Ω~0.976Ω(E24)
TCR (ppm/°C) -55°C ~ +155°C			
0.020Ω~0.043Ω			≤ ±1000 ppm/°C
0.047Ω~0.091Ω	≤ ± 200 ppm/°C	≤ ± 250 ppm/°C	≤ ± 200 ppm/°C
0.100Ω~0.976Ω	≤ ± 150 ppm/°C	≤ ± 200 ppm/°C	≤ ± 100 ppm/°C
Max. dissipation at T <sub>amb</sub> =70°C	1/3 W	1/4 W	1/2 W
Max. Operation Voltage (DC or RMS)	150V	50V	20V
Max. Overload Voltage (DC or RMS)	300V	100V	400V
Climatic category (IEC 60068)	55/155/56		
Basic specification	JIS C 5201-1:1998 / IEC 60068-2-58:2004		

Note :

1. This is the maximum voltage that may be continuously supplied to the resistor element, see “IEC publication 60115-8”
2. Max. Operation Voltage : So called RCWV (Rated Continuous Working Voltage) is determined by

$$RCWV = \sqrt{\text{Rated Power} \times \text{Resistance Value}} \text{ or Max. RCWV listed above, whichever is lower.}$$

## DIMENSIONS(unit : mm)

Part No	WW08P	WW06P	WW12P
<b>L</b>	2.00 ± 0.10	1.60 ± 0.10	3.10 ± 0.15
<b>W</b>	1.25 ± 0.10	0.80 ± 0.10	1.60 ± 0.15
<b>T</b>	0.50 ± 0.15	0.45 ± 0.15	0.55 ± 0.10
<b>Tb</b>	0.40 ± 0.20	0.30 ± 0.15	0.50 ± 0.25
<b>Tt</b>	0.40 ± 0.20	0.30 ± 0.10	0.50 ± 0.25

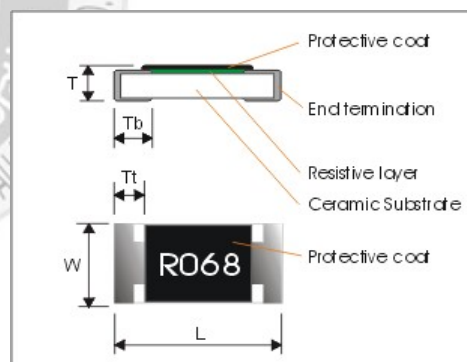

## MARKING

Each resistor is marked with a three-digit(WW06P ±1%;±5%) or four-digit(WW08P ±1%;±5%) code on the protective coating to designate the nominal resistance value.

\* Remark : 0603 resistor value from 0.1Ω to 0.976Ω E48/E96 series use 2 significant digits followed by letter.(Example R560 = R56 ; R402= 59Z)

\*\* Remark : 0603 resistor value from 0.047Ω to 0.091Ω use the last Two-digits followed by “M” equals “m”, means 1/1000(Example R047 = 47M ; R050= 50M)

## Rated Resistance

Resistance	Code 0805	Code 0603	Resistance	Code 0805	Code 0603	Resistance	Code 0805	Code 0603	Resistance	Code 0805	Code 0603
47mΩ	R047	47M	56mΩ	R056	56M	68mΩ	R068	68M	82mΩ	R082	82M
50mΩ	R050	50M	60mΩ	R060	60M	70mΩ	R070	70M	85mΩ	R085	85M
51mΩ	R051	51M	62mΩ	R062	62M	75mΩ	R075	75M	90mΩ	R090	90M
55mΩ	R055	55M	65mΩ	R065	65M	80mΩ	R080	80M	91mΩ	R091	91M

## FUNCTIONAL DESCRIPTION

### Product characterization

Standard values of nominal resistance are taken from the E96&E24 series for resistors with a tolerance of  $\pm 1\%$ ,  $\pm 5\%$ . The values of the E96/E24 series are in accordance with "IEC publication 60063".

### Derating

The power that the resistor can dissipate depends on the operating temperature; see Fig.2

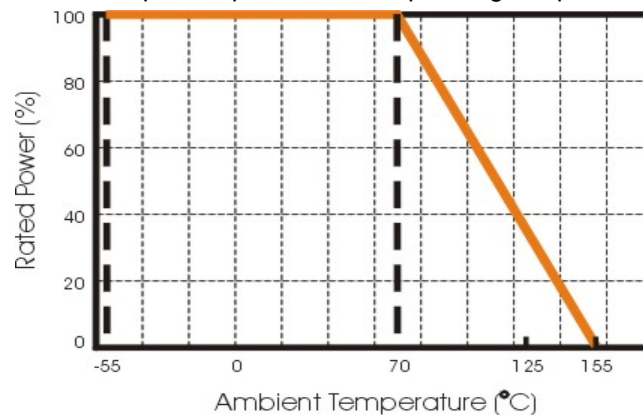

Fig.2 Maximum dissipation in percentage of rated power  
As a function of the ambient temperature

## MOUNTING

Due to their rectangular shapes and small tolerances, Surface Mountable Resistors are suitable for handling by automatic placement systems.

Chip placement can be on ceramic substrates and printed-circuit boards (PCBs).

Electrical connection to the circuit is by individual soldering condition.

The end terminations guarantee a reliable contact.

## SOLDERING CONDITION

The robust construction of chip resistors allows them to be completely immersed in a solder bath of 260°C for 10 seconds. Therefore, it is possible to mount Surface Mount Resistors on one side of a PCB and other discrete components on the reverse (mixed PCBs).

Surface Mount Resistors are tested for solderability at 235°C during 2 seconds. The test condition for no leaching is 260°C for 30 seconds. Typical examples of soldering processes that provide reliable joints without any damage are given in Fig 3.

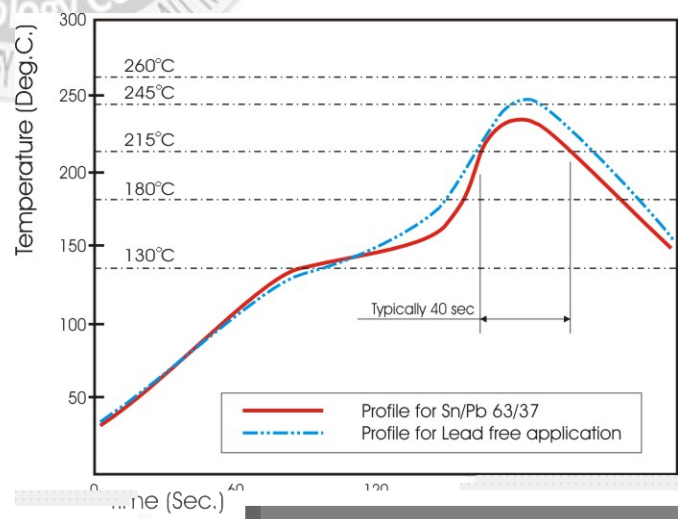

Fig 3. Infrared soldering profile for Chip Resistors

## CATALOGUE NUMBERS

The resistors have a catalogue number starting with.

WW08	P	R050	F	T	L
<b>Size code</b> WW12: 1206 WW08: 0805 WW06: 0603	<b>Type code</b> P :Power 0805 size=0.33W 0603 size=0.25W	<b>Resistance code</b> E96+E24: “R” is first digit followed by 3 significant digits.(0805) 50mΩ =R050 510mΩ =R510 “R” is first digit followed by 2 Significant digit.(0603) 100mΩ =R10 510mΩ =R51 0603 0.1Ω~0.976Ω E48/E96 2 significant digits followed by letter 0603 0.047Ω~0.091Ω E24 2 significant digits followed by M (M=milli Ω). (R047=47m)	<b>Tolerance</b> J : ±5% F : ±1%	<b>Packaging code</b> T : 7" Reeled taping paper taping 5Kpcs/reel.	<b>Termination code</b> L = Sn base (lead free)

- Reeled tape packaging : 8mm width paper taping 5000pcs per 7" reel.



## TEST AND REQUIREMENTS

Basic specification : JIS C 5201-1 : 1998

TEST	PROCEDURE	REQUIREMENT
<b>Clause 4.8</b> Temperature Coefficient of Resistance (TCR )	Natural resistance change per change in degree centigrade. $\frac{R_2 - R_1}{R_1(t_2 - t_1)} \times 10^6 \text{ (ppm/}^\circ\text{C)}$ R <sub>1</sub> : Resistance at reference temperature R <sub>2</sub> : Resistance at test temperature t <sub>1</sub> : 20°C+5°C-1°C.	Refer to quick reference data for T.C.R specification
<b>Clause 4.13</b> Short time overload	5.0× Rated power or Max. Overload Voltage for 5 sec. Measure resistance after 30 minutes.	ΔR/R max. J: ≤ ±(2%+0.5mΩ) F: ≤ ±(1%+0.5mΩ)
<b>Clause 4.18</b> Resistance to soldering heat(R.S.H)	Un-mounted chips completely immersed for 10±1second in a SAC solder bath at 260°C±5°C.	No visible damage ΔR/R max. J: ≤ ±(1%+0.5mΩ) F: ≤ ±(0.5%+0.5mΩ)
<b>Clause 4.17</b> Solderability	Un-mounted chips completely immersed for 2±0.5 second in a SAC solder bath at 235°C±5°C.	Good tinning (>95% covered) No visible damage
<b>Clause 4.19</b> Temperature cycling	1. 30 minutes at -55°C±3°C, 2. 2~3 minutes at 20°C+5°C-1°C, 3. 30 minutes at +155°C±3°C, 4. 2~3 minutes at 20°C+5°C-1°C, Total 5 continuous cycles.	No visible damage ΔR/R max. J: ≤ ±(1%+1mΩ) F: ≤ ±(0.5%+1mΩ)
<b>Clause 4.25</b> Load life (endurance)	1000 +48/-0 hours, loaded with RCWV or Vmax in chamber controller 70±2°C, 1.5 hours on and 0.5 hours off.	No visible damage ΔR/R max. J: ≤ ±(3%+0.5mΩ) F: ≤ ±(1%+0.5mΩ)
<b>Clause 4.24</b> Load life in Humidity	1000 +48/-0 hours, loaded with RCWV or Vmax in humidity chamber controller at 40°C±2°C and 90~95% relative humidity, 1.5hours on and 0.5 hours off.	No visible damage ΔR/R max. J: ≤ ±(3%+0.5mΩ) F: ≤ ±(1%+0.5mΩ)
<b>Clause 4.33</b> Bending strength	Resistors mounted on a 90mm glass epoxy resin PCB(FR4); bending : 3 mm, once for 10 seconds.	No visible damage ΔR/R max. J: ≤ ±(1%+1mΩ) F: ≤ ±(0.5%+1mΩ)
<b>Clause 4.32</b> Adhesion	Pressurizing force: 5N, Test time: 10±1sec.	No remarkable damage or removal of the terminations
<b>Clause 4.6</b> Insulation Resistance	Apply the maximum overload voltage (DC) for 1minute.	R ≥ 10GΩ
<b>Clause 4.7</b> Dielectric Withstand Voltage	Apply the maximum overload voltage (AC) for 1 minute.	No breakdown or flashover

## PACKAGING

Paper Tape specifications (unit :mm)

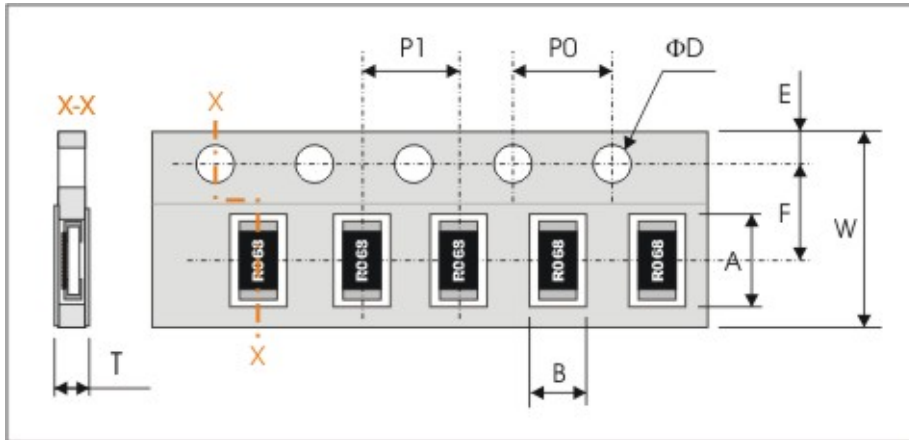

Series No.	A	B	W	F	E
WW06P	1.90±0.20	1.10±0.20	8.00±0.30	3.50±0.20	1.75±0.10
WW08P	2.40±0.20	1.65±0.20			
WW12P	3.60±0.20	2.00±0.20			

Series No.	P1	P0	ΦD	T
WW06P	4.00±0.10	4.00±0.10	Φ1.50 <sup>+0.1</sup> <sub>-0.0</sub>	0.65±0.05
WW08P				Max. 1.0
WW12P				

## Reel dimensions

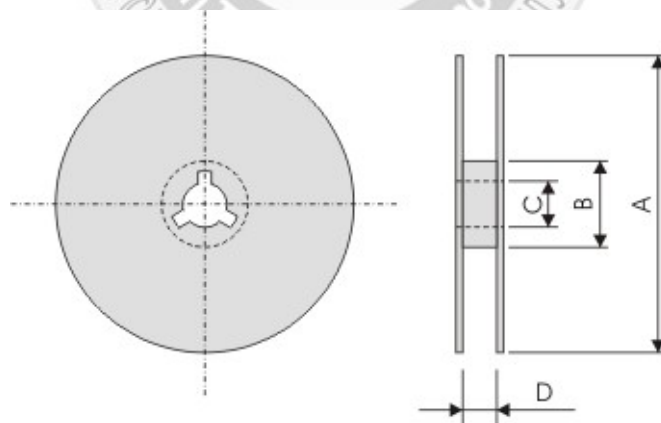

Symbol	A	B	C	D
(unit : mm)	Φ178.0±2.0	Φ60.0±1.0	13.0±0.2	9.0±0.5