

Power Metal Strip® Resistors, Very High Power (to 7 W), Low Value (down to 0.0003 Ω), Surface Mount

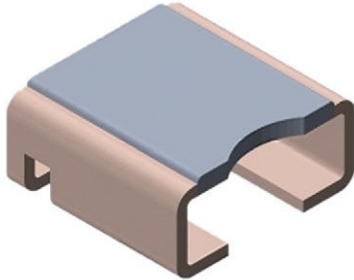

FEATURES

- High power to foot print size ratio
- Ideal for all types of current sensing, voltage division and pulse applications including switching and linear power supplies, instruments, power amplifiers, and shunts
- Proprietary processing technique produces extremely low resistance values, down to 0.0003 Ω
- Specially selected and stabilized materials allow for high power rating (to 7 W)
- All welded construction of the Power Metal Strip® resistors are ideal for all types of current sensing, voltage division and pulse applications
- Solid metal nickel-chrome or manganese-copper alloy resistive element with low TCR (< 20 ppm/°C)
- Very low inductance 0.5 nH to 5 nH
- Low thermal EMF (< 3 μV/°C)
- AEC-Q200 qualified ⁽¹⁾
- Material categorization: for definitions of compliance please see www.vishay.com/doc?99912

 AUTOMOTIVE
GRADE

RoHS
COMPLIANT
HALOGEN
FREE
GREEN
(5-2008)

DESIGN TOOLS (click logo to get started)



Notes

- Follow link to Overview of Automotive Grade Products for more details: www.vishay.com/doc?49924.
- ⁽¹⁾ Flame retardance test may not be applicable to some resistor technologies.

STANDARD ELECTRICAL SPECIFICATIONS						
GLOBAL MODEL	SIZE	POWER RATING $P_{70^{\circ}\text{C}}$ W	TOLERANCE ± %	RESISTANCE VALUE RANGE Ω	RESISTANCE VALUES CURRENTLY AVAILABLE ⁽²⁾ Ω	WEIGHT (typical) g/1000 pieces
WSLP2726	2726	5.0	1.0, 5.0	2m to 4m	2m, 3m, 4m	420
WSLP2726	2726	7.0	1.0, 5.0	0.3m to 1m	0.3m, 0.5m, 0.7m, 1m	420

Notes

- Power rating depends on the max. temperature at the solder point, component placement density and the substrate material.
- Part marking: Model, value, tolerance, date code.
- ⁽¹⁾ Other values may be available, contact factory.

GLOBAL PART NUMBER INFORMATION																	
Global Part Numbering: WSLP2726L5000FEA (visit www.vishay.net Vishay Dale parts numbering manual for all options)																	
W	S	L	P	2	7	2	6	L	5	0	0	0	F	E	A		
GLOBAL MODEL		RESISTANCE VALUE			TOLERANCE CODE		PACKAGING CODE ⁽¹⁾			SPECIAL							
WSLP2726		L = mΩ L5000 = 0.0005 Ω L7000 = 0.0007 Ω 1L000 = 0.0010 Ω 2L000 = 0.0020 Ω			F = ± 1.0 % J = ± 5.0 %		EA = lead (Pb)-free, tape/reel EK = lead (Pb)-free, bulk			(dash number) (up to 2 digits) from 1 to 99 as applicable							

Note

- ⁽¹⁾ Packaging code: EB (lead (Pb)-free) and TB (tin / lead) are non-standard packaging codes designating 1000 piece reels. These non-standard packaging codes are identical to our standard EA (lead (Pb)-free) and TA (tin / lead), except that they have a package quantity of 1000 pieces.

TECHNICAL SPECIFICATIONS		
PARAMETER	UNIT	RESISTOR CHARACTERISTICS
Component temperature coefficient (including terminal) ⁽¹⁾	ppm/°C	± 75 for 0.5 mΩ to 4 mΩ, ± 110 for 0.3 mΩ
Element TCR ⁽²⁾	ppm/°C	< 20
Operating temperature range	°C	-65 to +170
Maximum working voltage ⁽³⁾	V	$(P \times R)^{1/2}$

Notes

- (1) Component TCR - total TCR that includes the TCR effects of the resistor element and the copper terminal.
- (2) Element TCR - only applies to the alloy used for the resistor element; refer to item 1 in the construction illustration on the following page.
- (3) Maximum working voltage - the WSL is not voltage sensitive, but is limited by power / energy dissipation and is also not ESD sensitive.

DIMENSIONS in inches (millimeters)

MODEL	DIMENSIONS							
	L	W	H	R (REF.)	S	T	U	N
WSLP2726	0.272 ± 0.008 (6.9 ± 0.2)	0.260 + 0.012/- 0.008 (6.6 + 0.3/- 0.2)	Please see table below	0.195 (5.0)	0.028 ± 0.004 (0.7 ± 0.1)	0.016 ± 0.002 (0.4 ± 0.05)	0.078 ± 0.004 (2.0 ± 0.1)	0.039 ± 0.006 (0.99 ± 0.15)

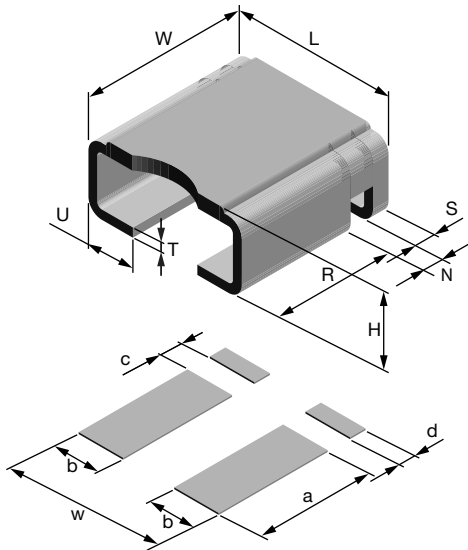

MODEL	SOLDER PAD DIMENSIONS				
	a	b	c	d	w
WSLP2726	0.220 (5.6)	0.096 (2.44)	0.035 (0.89)	0.035 (0.89)	0.290 (7.4)

MODEL	RESISTANCE VALUE (mΩ)	ELEMENT MATERIAL	HEIGHT H
WSLP2726	0.3	Mn-Cu	0.141 ± 0.008 (3.58 ± 0.2)
WSLP2726	0.5	Mn-Cu	0.116 ± 0.008 (2.95 ± 0.2)
WSLP2726	0.7	Mn-Cu	0.111 ± 0.008 (2.82 ± 0.2)
WSLP2726	1.0	Mn-Cu	0.1055 ± 0.008 (2.68 ± 0.2)
WSLP2726	2.0	Ni-Cr	0.114 ± 0.008 (2.9 ± 0.2)
WSLP2726	3.0	Ni-Cr	0.108 ± 0.008 (2.74 ± 0.2)
WSLP2726	4.0	Ni-Cr	0.1046 ± 0.008 (2.66 ± 0.2)

Notes

- 3D models available: www.vishay.com/doc?30314.
- Surface mount solder profile recommendations: www.vishay.com/doc?31052.



DERATING - AMBIENT TEMPERATURE

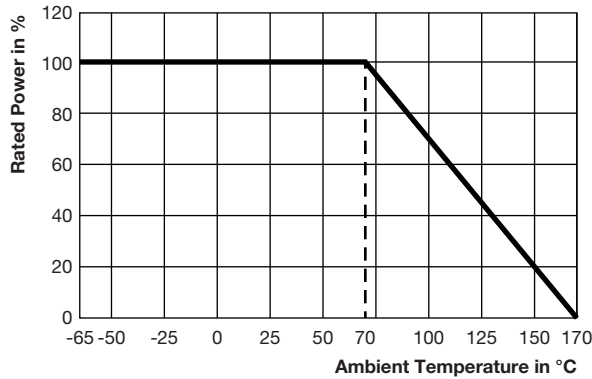

DERATING - TERMINAL TEMPERATURE

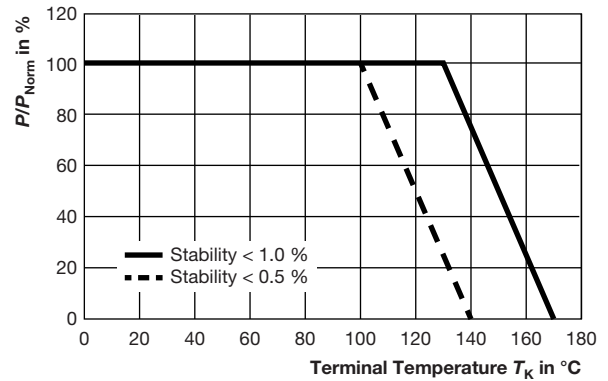

Example: WSLP2726 0.0005 Ω , 0.001 Ω

PERFORMANCE		
TEST	CONDITIONS OF TEST	TEST LIMITS
Thermal shock	-55 °C to +150 °C, 1000 cycles, 15 min at each extreme	± 0.5 %
Low temperature operation	65 °C for 45 min	± 0.5 %
High temperature exposure	1000 h at + 170 °C	± 1.0 %
Bias humidity	85 °C, 85 % RH, 10 % bias, 1000 h	± 0.5 %
Mechanical shock	100 g's for 6 ms, 5 pulses	± 0.5 %
Vibration	Frequency varied 10 Hz to 2000 Hz in 1 min, 3 directions, 12 h	± 0.5 %
Load life	1000 h at +70 °C, 1.5 h "ON", 0.5 h "OFF"	± 1.0 %
Resistance to solder heat	+260 °C solder, 10 s to 12 s dwell, 25 mm/s emergence	± 0.5 %
Moisture resistance	MIL-STD-202, method 106, 0 % power, 7b not required	± 0.5 %

PACKAGING (1)				
MODEL	REEL			
	TAPE WIDTH	DIAMETER	PIECES/REEL	CODE
WSLP2726	16 mm/embossed plastic	330 mm/13"	1500	EA

Notes

- Embossed carrier tape per EIA-481.
- (1) Additional packaging details at www.vishay.com/doc?20051.



Disclaimer

ALL PRODUCT, PRODUCT SPECIFICATIONS AND DATA ARE SUBJECT TO CHANGE WITHOUT NOTICE TO IMPROVE RELIABILITY, FUNCTION OR DESIGN OR OTHERWISE.

Vishay Intertechnology, Inc., its affiliates, agents, and employees, and all persons acting on its or their behalf (collectively, "Vishay"), disclaim any and all liability for any errors, inaccuracies or incompleteness contained in any datasheet or in any other disclosure relating to any product.

Vishay makes no warranty, representation or guarantee regarding the suitability of the products for any particular purpose or the continuing production of any product. To the maximum extent permitted by applicable law, Vishay disclaims (i) any and all liability arising out of the application or use of any product, (ii) any and all liability, including without limitation special, consequential or incidental damages, and (iii) any and all implied warranties, including warranties of fitness for particular purpose, non-infringement and merchantability.

Statements regarding the suitability of products for certain types of applications are based on Vishay's knowledge of typical requirements that are often placed on Vishay products in generic applications. Such statements are not binding statements about the suitability of products for a particular application. It is the customer's responsibility to validate that a particular product with the properties described in the product specification is suitable for use in a particular application. Parameters provided in datasheets and / or specifications may vary in different applications and performance may vary over time. All operating parameters, including typical parameters, must be validated for each customer application by the customer's technical experts. Product specifications do not expand or otherwise modify Vishay's terms and conditions of purchase, including but not limited to the warranty expressed therein.

Except as expressly indicated in writing, Vishay products are not designed for use in medical, life-saving, or life-sustaining applications or for any other application in which the failure of the Vishay product could result in personal injury or death. Customers using or selling Vishay products not expressly indicated for use in such applications do so at their own risk. Please contact authorized Vishay personnel to obtain written terms and conditions regarding products designed for such applications.

No license, express or implied, by estoppel or otherwise, to any intellectual property rights is granted by this document or by any conduct of Vishay. Product names and markings noted herein may be trademarks of their respective owners.