

DRAWING NUMBER:
611876-ENV

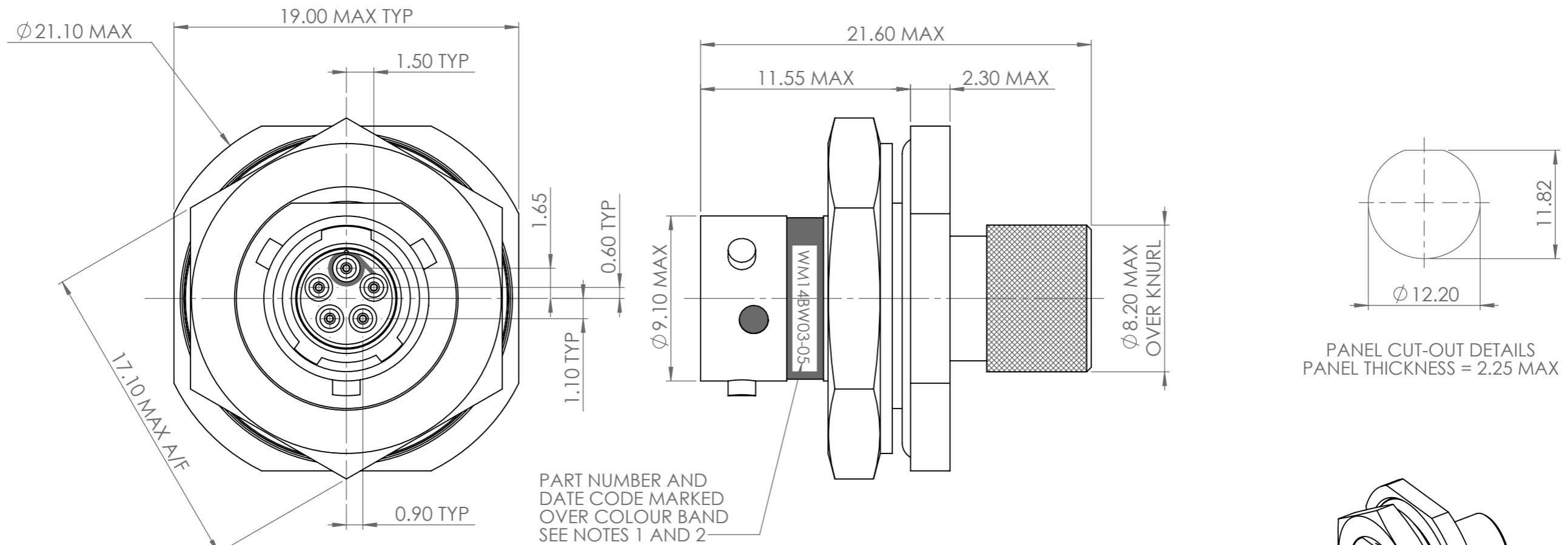

NOTES:

- CONNECTOR ORIENTATION IDENTIFIED BY COLOUR BAND AS BELOW :-

N ORIENTATION - RED	C ORIENTATION - ORANGE
A ORIENTATION - YELLOW	D ORIENTATION - GREEN
B ORIENTATION - BLUE	E ORIENTATION - GREY
- PART MARKING EXAMPLE:

H****D	WM 1 4 B W 03 - 05 S N - ***
DATE CODE	OPTION CODE
SERIES PREFIX	SHELL KEYING
SHELL ACCESSORY FEATURE	CONTACT TYPE
SHELL TYPE	INSERT ARRANGEMENT
COUPLING TYPE	SHELL SIZE
FINISH	
- MATERIALS :-
 - SHELL - ALUMINIUM ALLOY
 - CONTACTS - COPPER ALLOY GOLD PLATED
 - INSULATOR - HIGH GRADE PLASTIC
 - INTERFACIAL AND REAR SEALS - FLUOROSILICONE

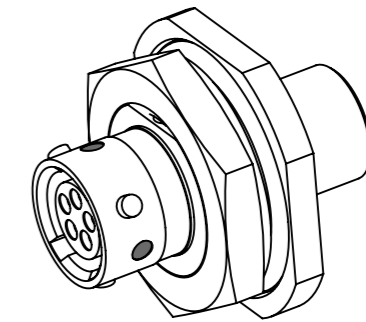

SCALE 2:1

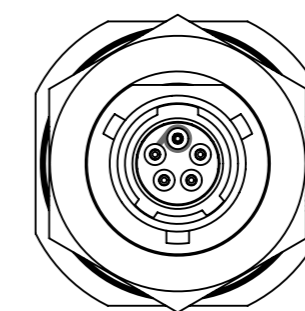

SOCKET INSERT VARIANT

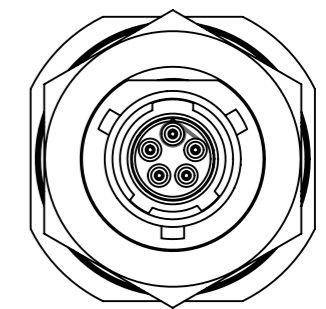

PIN INSERT VARIANT

BS8888 THIRD ANGLE PROJECTION		MATERIAL: SEE NOTE 3	FINISH: -----	 DEUTSCH TE CONNECTIVITY UK LTD., ST. LEONARDS-ON-SEA, TN38 9RF, UK.		
UNLESS OTHERWISE STATED: DIMENSIONS: mm [INCHES]		TITLE: RECEPT ASSY. WM SIZE 3 5 WAY. JAM NUT. LONG KNURL. ENVELOPE DETAILS. TYPE: CUSTOMER DRAWING				
IF IN DOUBT, ASK		SIZE: A3	SCALE: 4:1	DRAWING NUMBER: 611876-ENV	SHEET: 1 OF 1	ISSUE: AA

AA	DUK-71602	NDL	KSC	KJF	CEO	19/05/2020
ISSUE	CHANGE NOTE	DRAWN	CHECKED	APP. ENG.	APP. MARKETING	DATE

THIS INFORMATION IS CONFIDENTIAL AND PROPRIETARY TO TYCO ELECTRONICS CORPORATION AND ITS WORLDWIDE SUBSIDIARIES AND AFFILIATES (TE). IT MAY NOT BE DISCLOSED TO ANYONE OTHER THAN TE PERSONNEL, WITHOUT AUTHORIZATION FROM TE (www.te.com).