

WJA1500

+5 V Active-Bias InGaP HBT Gain Block

Applications

- IF Amplifier
- VHF/UHF Transmission
- Wireless Infrastructure
- CATV / SATV / MoCA
- General Purpose Wireless



SOT-89 Package

Product Features

- 50 Ohm Cascadable Gain Block
- 50-1000 MHz
- 19.5 dB Gain at 200 MHz
- +20.5 dBm P1dB at 200 MHz
- +43.5 dBm Output IP3 at 200 MHz
- +60 dBm Output IP2 at 200 MHz
- Single +5 V Supply, 95 mA Current
- Robust 1000V ESD, Class 1C
- SOT-89 Package

Functional Block Diagram

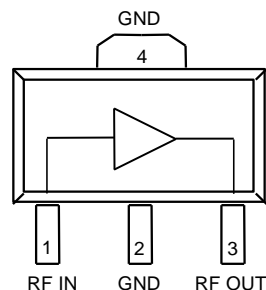

General Description

The WJA1500 is a cascadable gain block that offers high linearity in a low-cost surface-mount package. At 200 MHz, the WJA1500 typically provides 19.5 dB gain, +43.5 dBm OIP3, and +20.5 dBm P1dB. The device is housed in a RoHS-compliant SOT-89 industry-standard SMT package using a NiPdAu plating to eliminate the possibility of tin whiskering.

The WJA1500 consists of Darlington pair amplifiers using a high reliability InGaP/GaAs HBT process technology. The MMIC amplifier is internally matched to 50 Ω and only requires DC-blocking capacitors and a bias inductor for operation. An internal active bias is designed to enable stable performance over temperature. A dropping bias resistor is not required allowing the device to be biased directly from +5 V supply voltage.

The amplifier is targeted for high performance IF applications in existing and next generation wireless technologies. The WJA1500 is ideal for general purpose applications such as LO buffering, IF amplification and pre-driver stages within the 50 to 1000 MHz frequency range.

Pin Configuration

Pin #	Symbol
1	RF IN
3	RF OUT
2, 4	GND

Ordering Information

Part No.	Description
WJA1500	InGaP HBT Gain Block
WJA1500-PCB	50-1000 MHz Evaluation Board

Standard T/R size = 1000 pieces on a 7" reel

WJA1500

+5 V Active-Bias InGaP HBT Gain Block



Specifications

Absolute Maximum Ratings

Parameter	Rating
Storage Temperature	-55 to 150 °C
RF Input Power, CW, 50 Ω, T=25°C	+24 dBm
Supply Voltage	+6.5 V

Operation of this device outside the parameter ranges given above may cause permanent damage.

Recommended Operating Conditions

Parameter	Min	Typ	Max	Units
V _{cc}	+4.75	+5	+5.25	V
T _{case}	-40		+85	°C
T _j (for >10 ⁶ hours MTTF)			+150	°C

Electrical specifications are measured at specified test conditions. Specifications are not guaranteed over all recommended operating conditions.

Electrical Specifications

Test conditions unless otherwise noted: V_{supply}=+5 V, T_{CASE} = +25°C, 50 Ω system.

Parameter	Conditions	Min	Typical	Max	Units
Operational Frequency Range		50		1000	MHz
Test Frequency			200		MHz
Gain		17.8	19.4	20.8	dB
Input Return Loss			17		dB
Output Return Loss			21		dB
Output P1dB			+20.5		dBm
Output IP3	See Note 1.	+39	+43.7		dBm
Output IP2			+59.8		dBm
Noise Figure			5.0		dB
Device Voltage, V _{cc}			5.0		V
Device Current, I _{cc}		79	95	99	mA
Thermal Resistance (jnc to case) θ _{jc}				78	°C/W

Notes:

1. OIP3 is measured with two tones at an output power of +8 dBm / tone separated by 1 MHz. The suppression on the largest IM3 product is used to calculate the OIP3 using 2:1 rule. 2:1 rule gives relative value with respect to fundamental tone.

WJA1500

+5 V Active-Bias InGaP HBT Gain Block



Device Characterization Data

S-Parameter Data

$V_{\text{supply}} = +5 \text{ V}$, $I_{\text{cc}} = 94 \text{ mA}$, $T_{\text{case}} = +25^\circ \text{ C}$, fixture measurement, calibrated to device leads

Freq (MHz)	S11 (dB)	S11 (ang)	S21 (dB)	S21 (ang)	S12 (dB)	S12 (ang)	S22 (dB)	S22 (ang)
10	-15.69	-55.09	21.82	171.35	-25.19	11.61	-10.46	-28.13
50	-17.40	-135.23	19.98	168.76	-23.20	4.28	-18.29	-60.10
100	-17.59	-153.75	19.68	167.63	-23.05	0.79	-21.02	-64.45
150	-17.77	-158.44	19.59	164.26	-22.99	-1.17	-21.22	-67.20
200	-17.56	-160.17	19.47	160.44	-22.96	-2.89	-21.01	-73.21
250	-17.54	-160.17	19.42	157.05	-22.91	-4.24	-20.25	-76.35
300	-17.25	-159.36	19.36	153.10	-23.00	-5.88	-19.36	-80.46
350	-17.04	-156.92	19.33	148.71	-22.99	-6.83	-18.55	-83.44
400	-16.88	-156.28	19.26	144.56	-22.97	-8.61	-17.94	-86.00
450	-16.50	-152.39	19.19	140.90	-23.01	-9.69	-16.95	-90.06
500	-16.25	-152.53	19.10	136.81	-22.93	-10.49	-16.62	-92.43
550	-16.04	-151.61	19.01	132.74	-23.00	-12.61	-15.94	-96.08
600	-15.71	-149.87	18.90	128.80	-23.02	-13.57	-15.45	-98.43
650	-15.45	-147.51	18.80	124.94	-23.01	-14.81	-14.87	-101.00
700	-15.11	-146.25	18.69	120.76	-23.04	-15.97	-14.15	-104.13
750	-14.84	-144.74	18.58	117.69	-23.01	-17.76	-13.71	-106.18
800	-14.67	-144.80	18.45	113.29	-23.00	-19.31	-13.28	-108.81
850	-14.45	-143.29	18.38	109.27	-23.05	-19.69	-12.67	-111.55
900	-14.25	-141.96	18.20	105.66	-23.02	-21.32	-12.12	-114.03
950	-14.05	-141.12	18.16	101.96	-23.09	-22.91	-11.61	-116.73
1000	-13.98	-140.85	18.02	97.92	-23.14	-23.65	-11.22	-119.37
1050	-13.75	-140.40	17.84	94.26	-23.06	-24.91	-10.74	-121.30
1100	-13.40	-139.62	17.69	90.54	-23.10	-26.92	-10.34	-123.81
1150	-13.24	-138.81	17.60	86.83	-23.10	-28.23	-9.89	-125.85
1200	-13.05	-138.36	17.43	82.58	-23.24	-29.00	-9.59	-128.24

Device S-parameters are available for download at www.TriQuint.com

WJA1500

+5 V Active-Bias InGaP HBT Gain Block



Evaluation Board - WJA1500-PCB

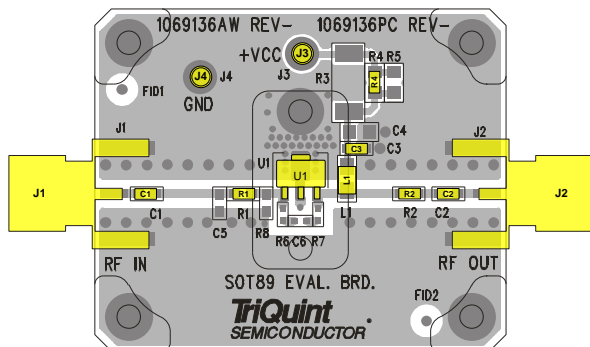

See Evaluation Board PCB Information section for material and stack up.

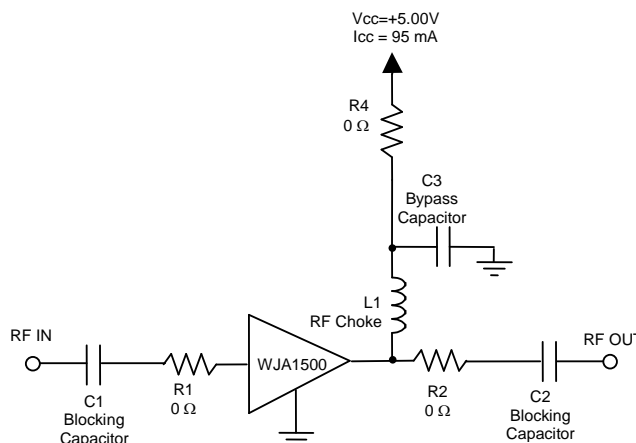

Bill of Material

Reference Des.	Value	Description	Manufacturer	Part Number
U1	n/a	InGaP HBT Gain Block	TriQuint	WJA1500
L1	470 nH	Ferrite core wire wound inductor, 0805 ⁽¹⁾	various	
C1, C2	1000 pF	Cap, Chip, 0603, 50V, NPO, 5%	various	
C3	0.018 uF	Cap, Chip, 0603, 16V, X7R, 10%	Coilcraft	
R1, R2, R4	0 Ω	Res, Chip, 0603, 1/10W, 5%	various	

Notes:

- For lower cost and performance (100 – 1000 MHz) option use 470 nH air core wire wound inductor.
- R1, R2, and R4 may be replaced by copper trace in end user applications.

Typical Performance - WJA1500-PCB

Test conditions unless otherwise noted: $V_{supply} = 5\text{ V}$, $I_{cc} = 94\text{ mA}$, $T_{case} = +25^\circ\text{C}$

Frequency	MHz	70	170	240	500	900
Gain	dB	19.6	19.3	19.2	18.8	17.6
Input Return Loss	dB	14	16	17	17	14
Output Return Loss	dB	25	27	22	15	10
Output P1dB	dBm	+20.2	+20.3	+20.4	+20.4	+19.9
Output IP3 [1]	dBm	+42.1	+44.6	+43.8	+38.3	+33.4
Output IP2	dBm	+63.2	+61.1	+58.0	+59.0	+52.0
Noise Figure	dB	4.9	4.9	5.0	5.2	5.8

Notes:

- OIP3 measured with two tones at an output power of +8 dBm / tone separated by 1 MHz. The suppression on the largest IM3 product is used to calculate the OIP3 using 2:1 rule.

WJA1500

+5 V Active-Bias InGaP HBT Gain Block



Performance Plots - WJA1500-PCB

Test conditions unless otherwise noted: $V_{supply} = 5\text{ V}$, $I_{cc} = 94\text{ mA}$, $T_{case} = +25\text{ }^{\circ}\text{C}$

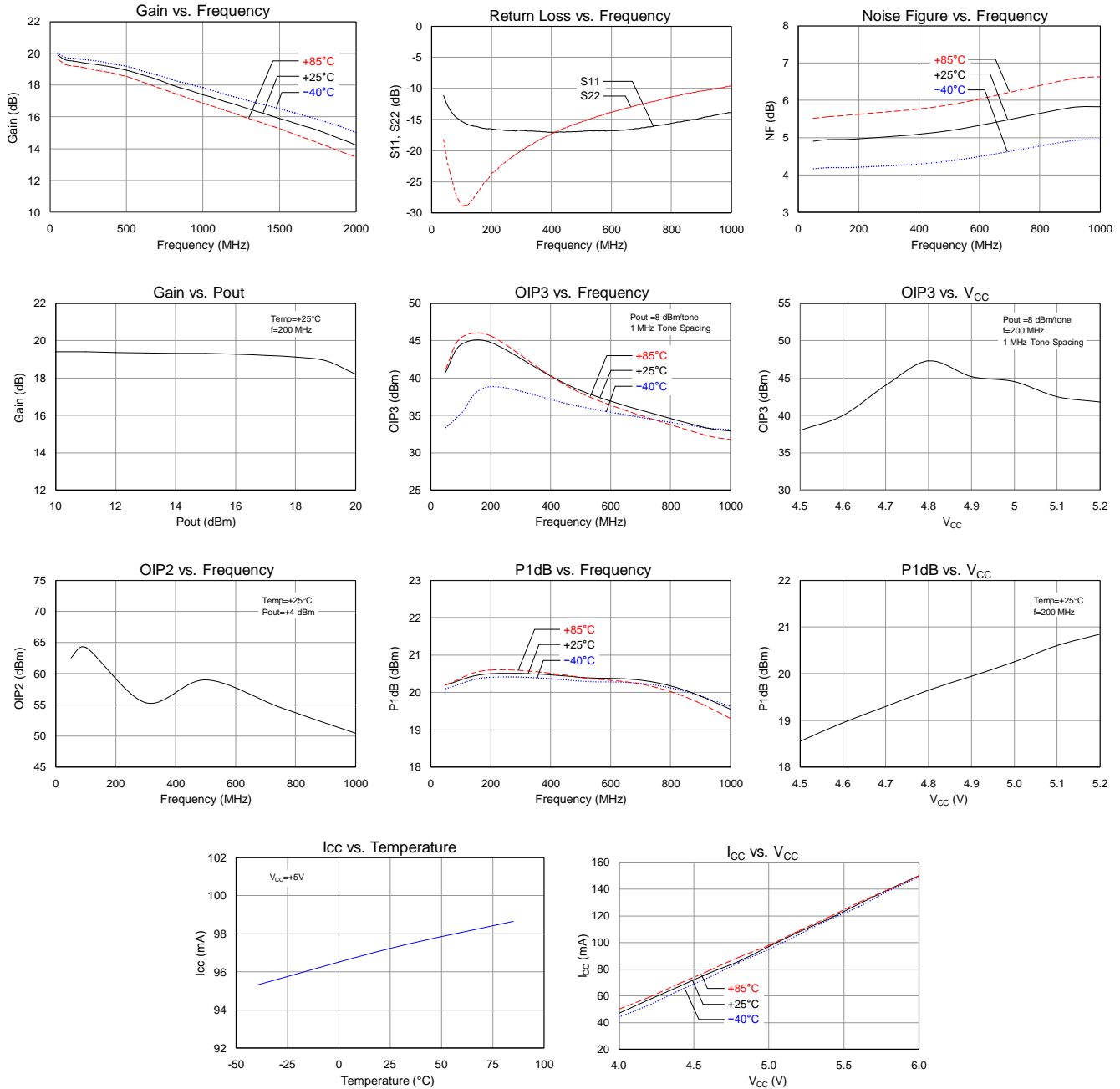

WJA1500

+5 V Active-Bias InGaP HBT Gain Block

Pin Description

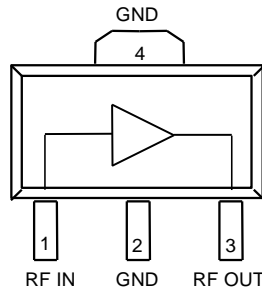

Pin	Symbol	Description
1	RF IN	RF input, matched to 50 ohms. External DC Block is required.
3	RF OUT	RF output / DC supply, matched to 50 ohms. External DC Block, bias choke required.
2, 4	GND Paddle	Backside Paddle. Multiple vias should be employed to minimize inductance and thermal resistance; see PCB mounting pattern in Mechanical Information section.

Evaluation Board PCB Information

TriQuint PCB 1069136 Material and Stack Up

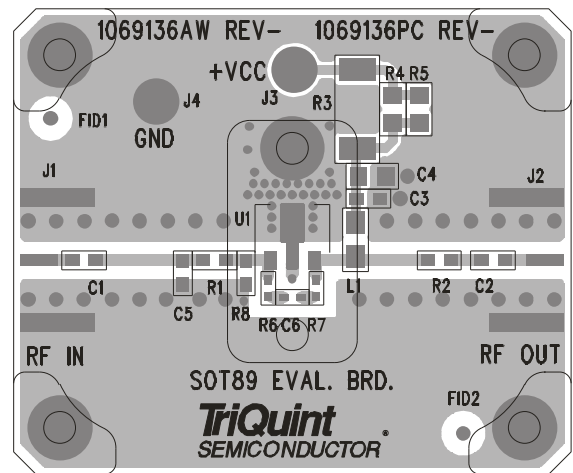
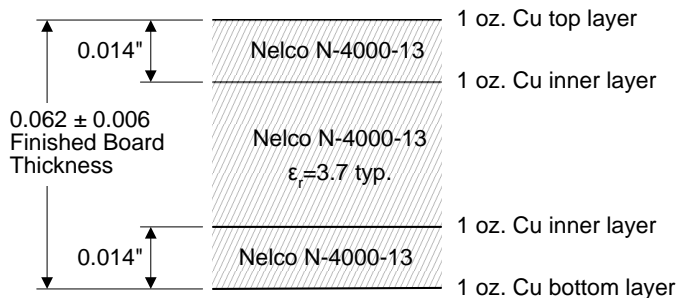

WJA1500

+5 V Active-Bias InGaP HBT Gain Block

Mechanical Information

Package Information and Dimensions

The component will be marked on the top surface of package with an "A1500" designator and an alphanumeric lot code.

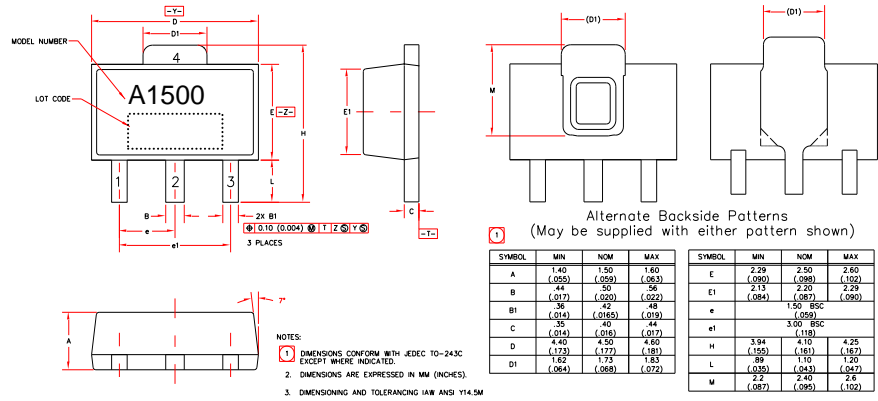

Mounting Configuration

All dimensions are in millimeters (inches). Angles are in degrees.

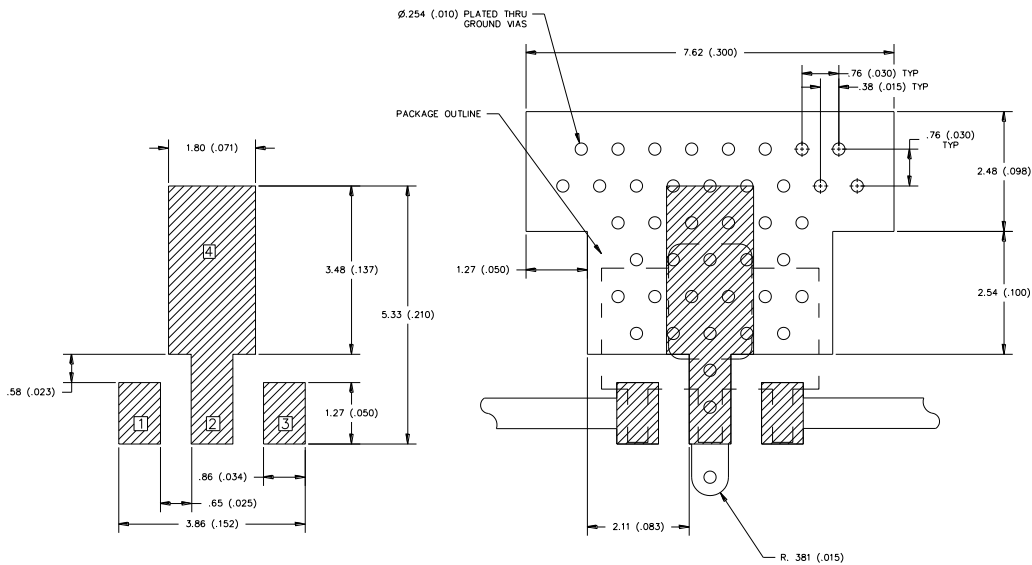

Notes:

1. Ground / thermal vias are critical for the proper performance of this device. Vias should use a .35mm (#80 / .0135") diameter drill and have a final plated thru diameter of .25 mm (.010").
2. Add as much copper as possible to inner and outer layers near the part to ensure optimal thermal performance.
3. RF trace width depends upon the PC board material and construction.
4. Use 1 oz. Copper minimum.
5. The pad pattern shown has been developed and tested for optimized assembly at TriQuint Semiconductor. The PCB land pattern has been developed to accommodate lead and package tolerances. Since surface mount processes vary from company to company, careful process development is recommended.

WJA1500

+5 V Active-Bias InGaP HBT Gain Block

Product Compliance Information

ESD Information



Caution! ESD-Sensitive Device

ESD Rating: Class 1C
Value: Passes ≥ 1000 V to < 2000 V
Test: Human Body Model (HBM)
Standard: JEDEC Standard JESD22-A114

ESD Rating: Class IV
Value: Passes ≥ 1000 V
Test: Charged Device Model (CDM)
Standard: JEDEC Standard JESD22-C101

MSL Rating

Moisture Sensitivity Level 3 at +260°C per JEDEC standard IPC/JEDEC J-STD-020.

Solderability

Package lead plating: NiPdAu

Compatible with both lead-free (260 °C max. reflow temperature) and tin/lead (245 °C max. reflow temperature) soldering processes.

RoHS Compliance

This part is compliant with EU 2002/95/EC RoHS directive (Restrictions on the Use of Certain Hazardous Substances in Electrical and Electronic Equipment).

This product also has the following attributes:

- Lead Free
- Halogen Free (Chlorine, Bromine)
- Antimony Free
- TBBP-A (C₁₅H₁₂Br₄O₂) Free
- PFOS Free
- SVHC Free

Contact Information

For the latest specifications, additional product information, worldwide sales and distribution locations, and information about TriQuint:

Web: www.triquint.com
Email: info-sales@tqs.com

Tel: +1.503.615.9000
Fax: +1.503.615.8902

For technical questions and application information:

Email: sjcapplications.engineering@tqs.com

Important Notice

The information contained herein is believed to be reliable. TriQuint makes no warranties regarding the information contained herein. TriQuint assumes no responsibility or liability whatsoever for any of the information contained herein. TriQuint assumes no responsibility or liability whatsoever for the use of the information contained herein. The information contained herein is provided "AS IS, WHERE IS" and with all faults, and the entire risk associated with such information is entirely with the user. All information contained herein is subject to change without notice. Customers should obtain and verify the latest relevant information before placing orders for TriQuint products. The information contained herein or any use of such information does not grant, explicitly or implicitly, to any party any patent rights, licenses, or any other intellectual property rights, whether with regard to such information itself or anything described by such information. TriQuint products are not warranted or authorized for use as critical components in medical, life-saving, or life-sustaining applications, or other applications where a failure would reasonably be expected to cause severe personal injury or death.