

Magnecraft General Purpose Relays

Catalog
2014



■ Series Overview	3
■ 792 Control Series	4
■ 781 Series	9
■ 782 Power Series	13
■ 783 Series	17
■ 784 Series	21
■ 750 Series	25
■ 788 Series	29
■ 782H Hazardous Location Series	33
■ 750H Hazardous Location Series	37
■ UL Listed Relay/Socket Combinations	41
■ Sockets and Accessories	42
□ Socket Specifications	42
□ Mounting Adapter Specifications	65
□ Socket Accessories	66
■ Application Data	73
■ Website Guide	75

Designed with specialized magnetic armatures and coils, Magnecraft General Purpose Relays easily handle current loads ranging from 10 mA to as large as 15 A. With multiple features, and a broad line of sockets and accessories, these relays offer the options needed to improve design, expedite installation and simplify testing of your application.

Key Features

- Socket, panel and DIN mounting options
- Multiple features and contact configurations available
- Optional protection, mounting, and identification accessories
- Ideal for MRO direct replacement
- UL Class I Division 2 models for hazardous locations

	Series	Features	Terminals	Contact Configuration	Output Current	Page
	792 Control	Plug-In Relay	Blade	DPDT and 4PDT	3–12 A	4
	781	Plug-In Relay	Blade	SPDT	15 A	9
	782 Power	Plug-In Relay	Blade	DPDT	15 A	13
	783	Plug-In Relay	Blade	3PDT	15 A	17
	784	Plug-In Relay	Blade	4PDT	15 A	21
	750	Plug-In Relay	Octal (8 Pin)	DPDT	10 A	25
			Octal (11 Pin)	3PDT	10 A	
	788	Plug-In Relay	Blade	DPDT and 3PDT	10 A	29
	782H	Hermetically Sealed Relay	Blade	4PDT	5 A	33
					3 A	
					1 A	
	750H	Hermetically Sealed Relay	Octal (8 Pin)	DPDT	12 A	37
			Octal (11 Pin)	3PDT	12 A	

Description

Magnecraft General Purpose Relays

792 Control Series

DPDT 12 A; 4PDT 6 A and 3 A



UL listed when used with proper Magnecraft sockets



792 Clear Cover



792 Full-Feature Cover

Description

The 792 Plug-in Control relays offer clear or full-feature covers with multiple mounting options and accessories; 4PDT models save valuable space while adding increased functionality.

Feature	Benefit
12 A / 6 A / 3 A switching current	Ideal for various automation panels and controls
Clear or full-feature cover options	Full-feature covers include LED indicator and locking test button to facilitate maintenance and expedite commissioning
DPDT and 4PDT contact options	Simultaneously control 2 or 4 separate circuits
Socket mount option	Simplifies installation and maintenance while also allowing the use of protection modules, hold-down clips and other accessories
Gold-flashed contacts	Reduces contact oxidation and increases shelf life
Mechanical flag indicator	Standard feature that displays relay status during testing or operation without having to power the relay

Contact Rating	Contact Configuration	Nominal Coil Voltage	Coil Resistance (Ω)	Contacts	Clear Cover Part Number	Clear Cover with LED Part Number	Full-Feature Cover Part Number
3 A	4PDT	12 Vac	44	Low Level Bifurcated	792XDX3C-12A	792XDX3CL-12A	792XDX3M4L-12A
		24 Vac	177		792XDX3C-24A	792XDX3CL-24A	792XDX3M4L-24A
		48 Vac	708		792XDX3C-48A	792XDX3CL-48A	792XDX3M4L-48A
		120 Vac	3630		792XDX3C-120A	792XDX3CL-120A	792XDX3M4L-120A
		240 Vac	17720		792XDX3C-240A	792XDX3CL-240A	792XDX3M4L-240A
		12 Vdc	160		792XDX3C-12D	792XDX3CL-12D	792XDX3M4L-12D
		24 Vdc	640		792XDX3C-24D	792XDX3CL-24D	792XDX3M4L-24D
		48 Vdc	2560		792XDX3C-48D	792XDX3CL-48D	792XDX3M4L-48D
		110 Vdc	13440		792XDX3C-110D	792XDX3CL-110D	792XDX3M4L-110D
		12 A	DPDT		12 Vac	44	Standard
24 Vac	177			792XBXC-24A	-	792XBXM4L-24A	
48 Vac	708			792XBXC-48A	-	792XBXM4L-48A	
120 Vac	3630			792XBXC-120A	-	792XBXM4L-120A	
240 Vac	17720			792XBXC-240A	-	792XBXM4L-240A	
12 Vdc	160			792XBXC-12D	-	792XBXM4L-12D	
24 Vdc	640			792XBXC-24D	-	792XBXM4L-24D	
48 Vdc	2560			792XBXC-48D	-	792XBXM4L-48D	
110 Vdc	13440			792XBXC-110D	-	792XBXM4L-110D	
6 A	4PDT			12 Vac	44	Standard	
		24 Vac	177	792XDXC-24A	792XDXCCL-24A		792XDXM4L-24A
		48 Vac	708	792XDXC-48A	792XDXCCL-48A		792XDXM4L-48A
		120 Vac	3630	792XDXC-120A	792XDXCCL-120A		792XDXM4L-120A
		240 Vac	17720	792XDXC-240A	792XDXCCL-240A		792XDXM4L-240A
		12 Vdc	160	792XDXC-12D	792XDXCCL-12D		792XDXM4L-12D
		24 Vdc	640	792XDXC-24D	792XDXCCL-24D		792XDXM4L-24D
		48 Vdc	2560	792XDXC-48D	792XDXCCL-48D		792XDXM4L-48D
		110 Vdc	13440	792XDXC-110D	792XDXCCL-110D		792XDXM4L-110D

Part Number Explanation

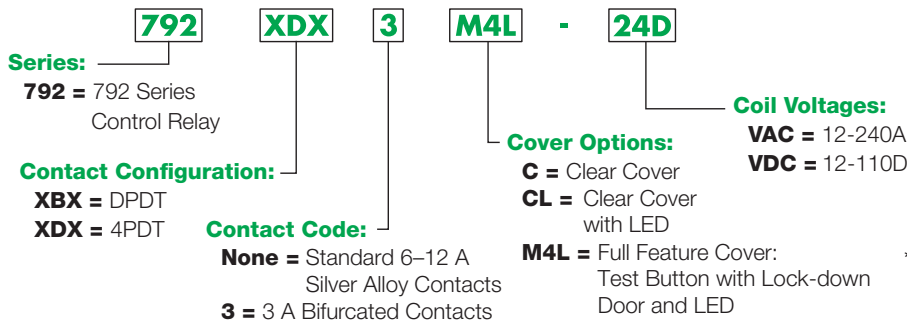

*Please contact Customer Service for more information (847-441-2540).

Specifications

Part Number	792XBX
Contact Characteristics	
Terminal Style	Blade
Contact Material	Silver Alloy
Contact Configuration	DPDT
Maximum Switching Current	12 A
Maximum Switching Voltage	IEC: 250 Vac / 28 Vdc UL/CSA: 300 Vac / 30 Vdc
Rated Operational Current (Conforming to IEC)	Resistive: 12 A at 250 Vac Resistive: 12 A at 28 Vdc
Rated Operational Current (Conforming to UL)	Resistive: 12 A / 277 Vac, 100k cycles Resistive: 12 A / 120 Vac, 200k cycles Resistive: 12 A / 30 Vdc, 100k cycles Motor: 1/2 hp / 120 Vac, 6k cycles Motor: 1 hp / 277 Vac, 6k cycles B300 PILOT DUTY, 6k cycles
Minimum Switching Requirement	10 mA at 17 Vdc (170 mW)
Coil Characteristics	
Maximum Operating Voltage	110% (AC / DC)
Maximum Pickup Voltage	80% (AC); 80% (DC)
Drop-out Voltage Threshold	15% (AC); 10% (DC)
Average Consumption	0.9–1.2 VA (AC); 0.8–1.1 W (DC)
General Characteristics	
Electrical Life at Rated Load	200,000 operations (where stated)
Mechanical Life (Unpowered)	10,000,000 operations
Operating Time	25 ms max. at 80% rated coil voltage 20 ms max. at 100% rated coil voltage
Release time	20 ms max. (DC) 35 ms max. (AC)
Impulse Withstand Voltage	4 kV (1.2 / 50 μs)
Dielectric Strength - Between Coil and Contact (AC)	2000 V(rms)
Dielectric Strength - Between Poles (AC)	2000 V(rms)
Dielectric Strength - Between Contacts (AC)	1300 V(rms)
Ambient Air Temperature around the Device - Storage	-40 – +85 °C (-40 – +185 °F)
Ambient Air Temperature around the Device - Operation	-40 – +55 °C (-40 – +131 °F)
Vibration Resistance - In Operation	3 g-n at 35–150 Hz
Vibration Resistance - Not Operating	5 g-n at 35–150 Hz
Shock Resistance - In Operation	10 g-n
Shock Resistance - Not Operating	30 g-n
Degree of Protection	IP 40
Weight	37 g (1.31 oz)
Agency Approvals	UL with socket, UR (E48539), CE, CSA (225619), RoHS

Note: Actual product performance may vary depending on application and environmental conditions.

Specifications (continued)

Part Number	792XDX	792XDX3
Contact Characteristics		
Terminal Style	Blade	Blade
Contact Material	Silver Alloy	Bifurcated
Contact Configuration	4PDT	4PDT
Maximum Switching Current	6 A	3 A
Load Type	Standard	Low Level
Maximum Switching Voltage	300 V	300 V
Rated Operational Current (Conforming to IEC)	Resistive: 6 A at 250 Vac Resistive: 6 A at 28 Vdc	Resistive: 3 A at 250 Vac Resistive: 3 A at 28 Vdc
Operational Current (Conforming to UL)	Resistive: 6 A at 277 Vac, 200k cycles Resistive: 8 A at 120 Vac, 200k cycles Resistive: 8 A at 30 Vdc, 200k cycles Motor: 1/3 hp at 120 Vac, 6k cycles Motor: 1/2 hp at 277 Vac, 6k cycles Pilot Duty: B300, 6k cycles	General Purpose: 3 A at 240–277 Vac General Purpose: 3 A at 120 Vac Resistive: 3 A at 30 Vdc Motor: 1/16 hp (2.8 A FLA) at 120 Vac Pilot Duty: 5 A make, 0.5 A break, 3 A continuous at 120 Vac
Minimum Switching Requirement	10 mA at 17 Vdc (170 mW)	3 mA at 5 Vdc (15 mW)
Coil Characteristics		
Maximum Operating Voltage	110% (AC / DC)	110% (AC / DC)
Maximum Pickup Voltage	80% (AC); 80% (DC)	80% (AC); 80% (DC)
Drop-out Voltage Threshold	15% (AC); 10% (DC)	15% (AC); 10% (DC)
Average Consumption	0.9–1.2 VA (AC); 0.8–1.1 W (DC)	0.9–1.2 VA (AC); 0.8–1.1 W (DC)
General Characteristics		
Electrical Life at Rated Load	200,000 operations (where stated)	100,000 (gen. purpose load) operations
Mechanical Life (Unpowered)	10,000,000 operations	10,000,000 operations
Operating Time	25 ms max. at 80% rated coil voltage 20 ms max. at 100% rated coil voltage	25 ms max. at 80% rated coil voltage 20 ms max. at 100% rated coil voltage
Release time	20 ms max. (DC) 35 ms max. (AC)	20 ms max. (DC) 35 ms max. (AC)
Impulse Withstand Voltage	4 kV (1.2 / 50 μs)	4 kV (1.2 / 50 μs)
Dielectric Strength - Between Coil and Contact (AC)	2000 V(rms)	2000 V(rms)
Dielectric Strength - Between Poles (AC)	1600 V(rms)	1600 V(rms)
Dielectric Strength - Between Contacts (AC)	1300 V(rms)	1300 V(rms)
Ambient Air Temperature around the Device - Storage	-40 – +85 °C (-40 – +185 °F)	-40 – +85 °C (-40 – +185 °F)
Ambient Air Temperature around the Device - Operation	-40 – +55 °C (-40 – +131 °F)	-40 – +55 °C (-40 – +131 °F)
Vibration Resistance - In Operation	3 g-n at 35–150 Hz	3 g-n at 35–150 Hz
Vibration Resistance - Not Operating	5 g-n at 35–150 Hz	5 g-n at 35–150 Hz
Shock Resistance - In Operation	10 g-n	10 g-n
Shock Resistance - Not Operating	30 g-n	30 g-n
Degree of Protection	IP 40	IP 40
Weight	37 g (1.31 oz)	37 g (1.31 oz)
Agency Approvals	UL with socket, UR (E48539), CE, CSA (225619), RoHS	

Note: Actual product performance may vary depending on application and environmental conditions.

Dimensions — inches (millimeters)

Clear Cover Dimension

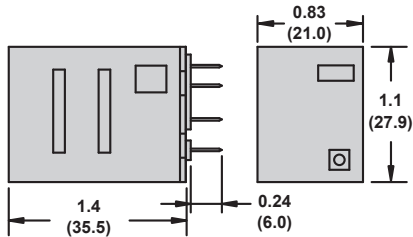

Full-Feature Cover Dimension

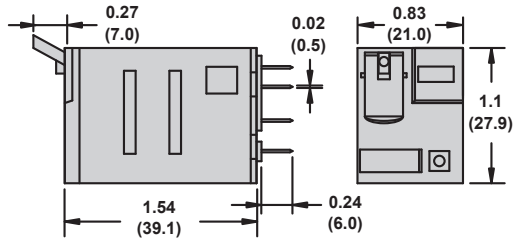

Wiring Diagrams

DPDT

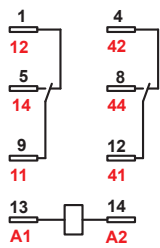

NEMA
IEC

4PDT

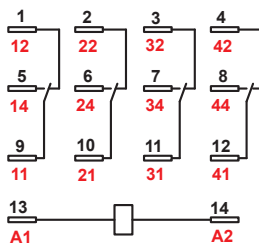

NEMA
IEC

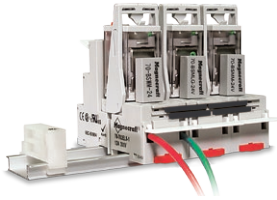

Description

Optional sockets offer customizable, Fingersafe™ solutions including protection modules, hold-down clips, and ID tags. Sockets are DIN rail and panel mount compatible.

Relay Accessories

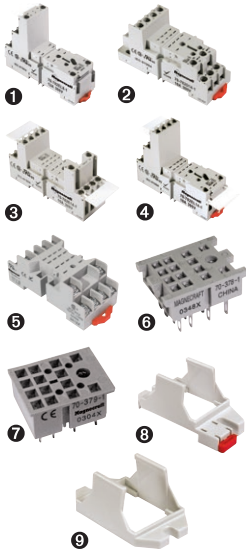

Description	Function	For Use With Relays	Pkg. Min.	Standard Part Number
Socket 1	DIN/Panel mount with elevator terminals	792XBX	10	70-782EL8-1
Socket 2	DIN/Panel mount with screw terminals and clamping plates	792XBX / 792XDX	10	70-782D14-1
Socket 3	DIN/Panel mount with rising elevator box terminals	792XBX / 792XDX	10	70-782E14-1
Socket 4	DIN/Panel mount with elevator terminals	792XBX / 792XDX	10	70-782EL14-1
Socket 5	DIN/Panel mount with screw terminals and clamping plates	792XDX	10	70-461-1
Socket 6	Solder terminals for chassis mount	792XDX	10	70-378-1
Socket 7	Printed circuit terminals for PCB mount	792XDX	10	70-379-1
Adapter 8	Mount directly to DIN rail	792XBX / 792XDX	10	16-782C
Adapter 9	Mount directly to panel	792XBX / 792XDX	10	16-782C1

Socket Accessories



Description	Function	For Use With Sockets	Coil Voltage	Pkg. Min.	Standard Part Number
Metal Spring Clip 1	Secures relay in socket	70-782D14-1, 70-782E14-1, 70-782EL14-1, 70-782EL8-1	–	10	16-782SC
Plastic Hold-Down Clip 2	Secures relay in socket or ejects relay off socket		–	10	16-782PC-1
Write-on tag 3	Small Write-on tag	–	–	10	16-782FT-1
Write-on tag 4	Write-on tag for 16-782PC-1 Hold-down Clip	–	–	10	16-700ST-1
Extruded Aluminum DIN Rail, 39.37" (1000 mm) 5	Quick installation and removal of sockets	70-782D14-1, 70-782E14-1, 70-782EL8-1, 70-782EL14-1	–	10	16-700DIN
DIN Rail End Clip 5	Holds sockets firmly in place on DIN rail	–	–	10	16-DCLIP-1
Insulated Coil Bus Jumper System 6	Wireless socket connection	70-782EL8-1, 70-782EL14-1	–	10	16-782CBJ-1
Small Socket Module	Protection Diode (Protects external drive circuitry from inductive voltages)	70-782D14-1, 70-782E14-1, 70-782EL14-1, 70-782EL8-1	6 to 250 Vdc	10	70-BSMD-250
Small Socket Module 7	LED Indicator (Provides coil status at a glance)		24 Vac/Vdc	10	70-BSMLG-24
Small Socket Module	MOV Suppressor (Protects from damaging electrical spikes)		120 Vac/Vdc	10	70-BSMM-120
			24 Vac/Vdc	10	70-BSMM-24
			240 Vac/Vdc	10	70-BSMM-240

Note: Use of LED socket module may increase coil power draw by up to 10%.

Description

Magnecraft General Purpose Relays

781 Series

SPDT 15 A



UL listed when used with proper Magnecraft sockets



781 Clear Cover



781 Full-Feature Cover

Description

The 781 Series plug-in relays offer clear or full-feature covers with multiple mounting options and accessories.

Feature	Benefit
15 A max. switching current	Ideal for automation control panels
14 mm width	Slim design saves valuable space
Clear or full-feature cover options	Full-feature covers include LED indicator and locking test button
Socket mount option	Simplifies installation and maintenance while also allowing the use of protection modules, hold-down clips and other accessories
Gold-flashed contacts	Reduces contact oxidation and increases shelf life
Mechanical flag indicator	Standard feature displays relay status during testing or operation

Contact Rating	Contact Configuration	Nominal Voltage	Coil Resistance (Ω)	Standard Part Number: Clear Cover	Standard Part Number: Full-Feature
15 A	SPDT	24 Vac 50/60 Hz	180	781XAXRC-24A	781XAXRM4L-24A
		120 Vac 50/60 Hz	4430	781XAXRC-120A	781XAXRM4L-120A
		240 Vac 50/60 Hz	15720	–	781XAXRM4L-240A
		12 Vdc	188	781XAXRC-12D	781XAXRM4L-12D
		24 Vdc	750	781XAXRC-24D	781XAXRM4L-24D

Part Number Explanation

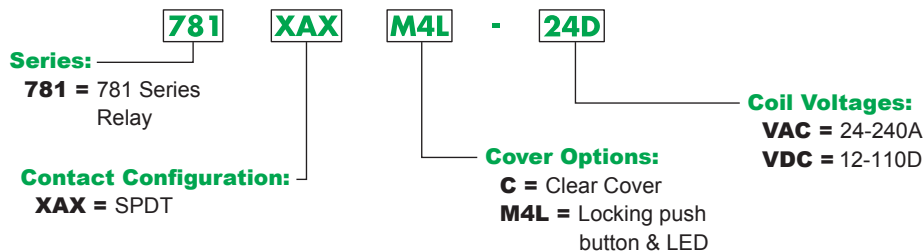

*Please note that LED-only versions are also available.
Please contact Customer Service for more information (847-441-2540).

Specifications (UL 508)

Part Number	781XAX
Contact Characteristics	
Terminal Style	Blade
Contact Configuration	SPDT
Maximum Current	15 A
Contact Materials	Silver Alloy
Maximum Switching Voltage	300 V
Rated Switching Current at Voltage	Resistive: 15 A at 277 Vac 50/60 Hz; 15 A at 28 Vdc Motor: 1 hp at 250 Vac 50/60 Hz; 1/2 hp at 120 Vac 50/60 Hz Pilot Duty: B300
Minimum Switching Requirement	100 mA at 5 Vdc (0.5 W)
Coil Characteristics	
Maximum Operating Voltage	110% (AC / DC)
Maximum Pickup Voltage	85% (AC / DC)
Drop-out Voltage Threshold	15% (AC); 10% (DC)
Average Consumption	1.2 VA (AC); 1.0 W (DC)
General Characteristics	
Electrical Life at Rated Load	100,000 operations
Mechanical Life (Unpowered)	10,000,000 operations
Operating Time (Response Time)	20 ms
Dielectric Strength - Between Coil and Contact (AC)	2000 V(rms)
Dielectric Strength - Between Contacts (AC)	1500 V(rms)
Ambient Air Temperature around the Device - Storage	-40 – +85 °C (-40 – +185 °F)
Ambient Air Temperature around the Device - Operation	-40 – +55 °C (-40 – +131 °F)
Vibration Resistance - Operational	+/- 1 mm (10–35 Hz) and 3 g-n (35–150 Hz)
Shock Resistance	15 g-n
Degree of Protection	IP 40
Weight	29 g (1.02 oz)
Agency Approvals	UL with socket, UR (E43641), CE, CSA (225619), RoHS

Note: Actual product performance may vary depending on application and environmental conditions.

Dimensions — inches (millimeters)

Clear Cover Dimensions

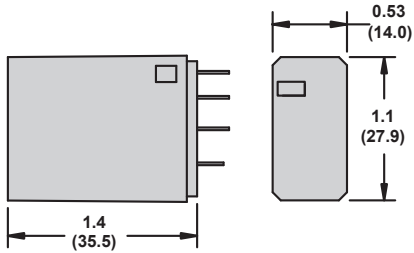

Full-Feature Cover Dimensions

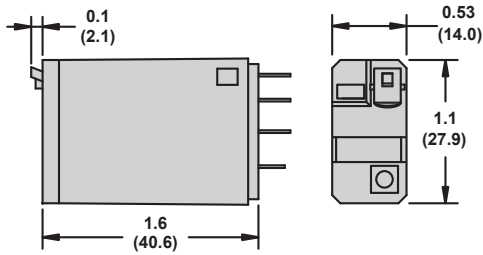

Wiring Diagram

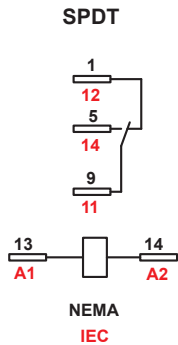

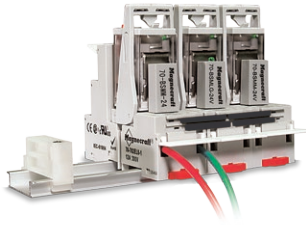

Description

Optional sockets offer customizable, Fingersafe solutions including protection modules, hold-down clips, and ID tags. Sockets are DIN rail and panel mount compatible.

Relay Accessories

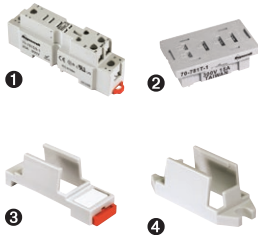

Description	Function	For Use With Relays	Pkg. Min.	Standard Part Number
Socket 1	DIN/Panel mount with screw terminals and clamping plates	781	10	70-781D5-1A
Socket 2	PCB-mount socket		10	70-781T-1
Adapter 3	Mount directly to DIN rail		10	16-781C
Adapter 4	Mount directly to panel		10	16-781C1

Socket Accessories



Description	Function	For Use With Sockets	Coil Voltage	Pkg. Min.	Standard Part Number
Metal Spring Clip 1	Secures relay in socket	70-781D5-1A,, 70-781T-1	–	10	16-781SC
Plastic ID Hold-Down Clip 2	Secures relay in socket and provides labeling	70-781D5-1A	–	10	16-781IDC
Extruded Aluminum DIN Rail, 39.37" (1000 mm) 3	Quick installation and removal of sockets	70-781D5-1A	–	10	16-700DIN
DIN Rail End Clip 3	Holds sockets firmly in place on DIN rail	–	–	10	16-DCLIP-1
Small Socket Module	Protection Diode (Protects external drive circuitry from inductive voltages)	70-781D5-1A	6 to 250 Vdc	10	70-BSMD-250
Small Socket Module 4	LED Indicator (Provides coil status at a glance)		24 Vac/Vdc	10	70-BSMLG-24
Small Socket Module	MOV Suppressor (Protects from damaging electrical spikes)		120 Vac/Vdc	10	70-BSMM-120
			24 Vac/Vdc	10	70-BSMM-24
			240 Vac/Vdc	10	70-BSMM-240

Note: Use of LED socket module may increase coil power draw by up to 10%.

Description

Magnecraft General Purpose Relays

782 Power Series

DPDT 15 A



UL listed when used with proper Magnecraft sockets



782 Clear Cover



782 Full-Feature Cover

Description

The 782 Plug-in Power relays offer clear or full-feature covers with multiple mounting options and accessories.

Feature	Benefit
15 A switching current	Ideal for automation control panels
Clear or full-feature cover options	Full-feature covers include LED indicator and locking test button
Socket mount option	Simplifies installation and maintenance while also allowing the use of protection modules, hold-down clips and other accessories
Gold-flashed contacts	Reduces contact oxidation and increases shelf life
Mechanical flag indicator	Standard feature displays relay status during testing or operation

Contact Rating	Contact Configuration	Nominal Voltage	Coil Resistance (Ω)	Feature	Standard Part Number: Clear Cover	Standard Part Number: Full-Feature
15 A	DPDT	24 Vac 50/60 Hz	180	-	782XBXC-24D	782XBXM4L-24A
				LED	782XBXCL-24A	-
		120 Vac 50/60 Hz	4430	-	782XBXC-120A	782XBXM4L-120A
				PC Terminals	782XBXCT-120A	-
		220/240 Vac 50/60 Hz	15720	-	782XBXC-24A	782XBXM4L-240A
		12 Vdc	160	-	782XBXC-12D	782XBXM4L-12D
				PC Terminals	782XBXCT-12D	-
		24 Vdc	650	-	-	782XBXM4L-24D
				PC Terminals	782XBXCT-24D	-
		110 Vdc	11000	-	782XBXC-110D	782XBXM4L-110D
				LED	782XBXCL-110D	-

Part Number Explanation

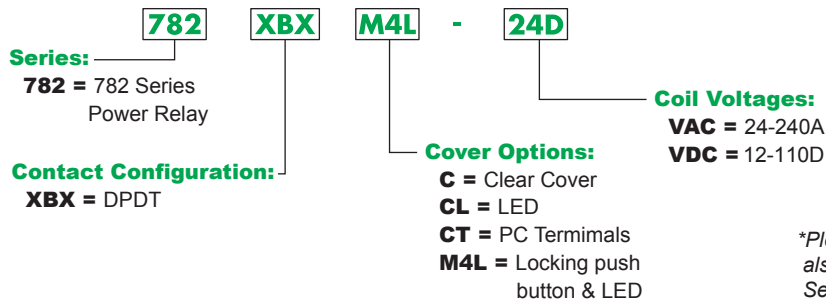

**Please note that LED-only versions are also available. Please contact Customer Service for more information (847-441-2540).*

Specifications (UL 508)

Part Number	782XBXC / CL / M4L	782XBXCT
Contact Characteristics		
Terminal Style	Blade	PC Terminals
Contact Configuration	DPDT	
Maximum Current	15 A	
Contact Materials	Silver Alloy	
Maximum Switching Voltage	300 V	
Rated Switching Current at Voltage	Resistive: 10 A at 277 Vac 50/60 Hz (CSA); 12 A at 277 Vac 50/60 Hz; 15 A at 120 Vac 50/60 Hz; 12 A at 28 Vdc Motor: 1 hp at 250 Vac 50/60 Hz; 1/2 hp at 120 Vac 50/60 Hz Pilot Duty: B300	
Minimum Switching Requirement	100 mA at 5 Vdc (0.5 W)	
Coil Characteristics		
Maximum Operating Voltage	110% (AC / DC)	
Maximum Pickup Voltage	85% (AC); 80% (DC)	
Drop-out Voltage Threshold	15% (AC); 10% (DC)	
Average Consumption	1.2 VA (AC); 0.9 W (DC)	
General Characteristics		
Electrical Life at Rated Load	100,000 operations	
Mechanical Life (Unpowered)	10,000,000 operations	
Operating Time (Response Time)	20 ms	
Dielectric Strength - Between Coil and Contact (AC)	2000 V(rms)	
Dielectric Strength - Between Poles (AC)	2000 V(rms)	
Dielectric Strength - Between Contacts (AC)	1500 V(rms)	
Ambient Air Temperature around the Device - Storage	-40 – +85 °C (-40 – +185 °F)	
Ambient Air Temperature around the Device - Operation	-40 – +55 °C (-40 – +131 °F)	
Vibration Resistance - Operational	+/- 1 mm (10–35 Hz) and 3 g-n (35–150 Hz)	
Shock Resistance	15 g-n	
Degree of Protection	IP 40	
Weight	36 g (1.27 oz)	
Agency Approvals	UL with socket, UR (E43641), CE, CSA (225619), RoHS	

Note: Actual product performance may vary depending on application and environmental conditions.

Dimensions — inches (millimeters)

Clear Cover Dimensions

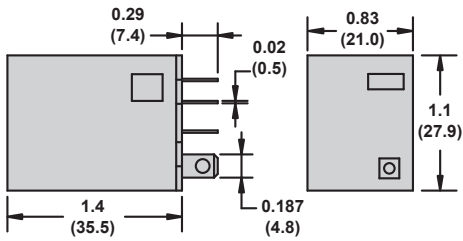

Printed Circuit Terminals

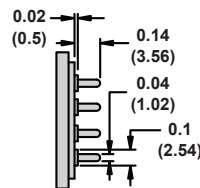

Full-Feature Cover Dimensions

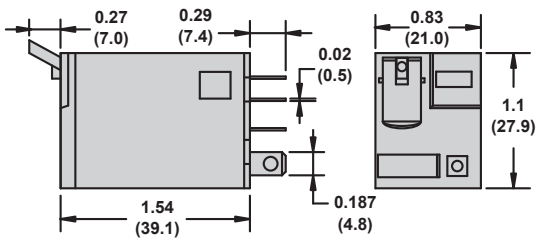

Terminal Layout

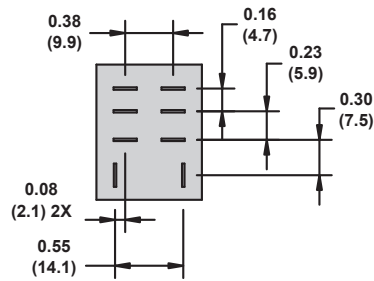

Wiring Diagram

DPDT

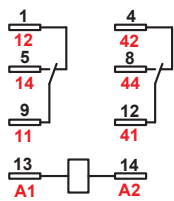

NEMA
IEC

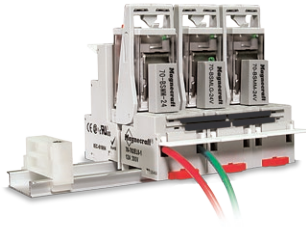

Description

Optional sockets offer customizable, Fingersafe solutions including protection modules, hold-down clips, and ID tags. Sockets are DIN rail and panel mount compatible.

Relay Accessories

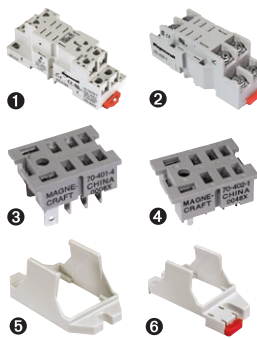

Description	Function	For Use With Relays	Pkg. Min.	Standard Part Number
Socket 1	DIN/Panel mount with screw terminals and clamping plates	782XAX / 782XBX	10	70-782D8-1A
Socket 2	DIN/Panel mount with screw terminals and clamping plates		10	70-459-1
Socket 3	Quick Connect terminals for chassis mount		10	70-401-1
Socket 4	Printed circuit terminals for PCB mount		10	70-402-1
Adapter 5	Mount directly to panel		10	16-782C1
Adapter 6	Mount directly to DIN rail		10	16-782C

Socket Accessories

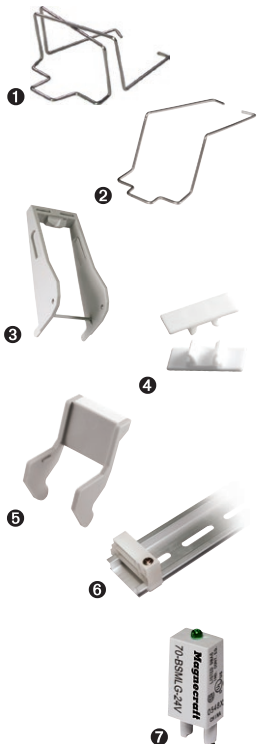

Description	Function	For Use With Sockets	Coil Voltage	Pkg. Min.	Standard Part Number
Metal Spring Clip 1 2	Secures relay in socket	70-782D8-1A, 70-459-1, 70-401-1, 70-402-1	–	10	16-1342
Plastic Hold-Down Clip 3	Secures relay in socket or ejects relay off socket	70-782D8-1A	–	10	16-782PC-1
Write-on tag 4	Write-on tag for 16-782PC-1 hold-down Clip	–	–	10	16-700ST-1
Plastic ID Hold-Down Clip 5	Secures relay in socket and provides labeling	70-782D8-1A, 70-459-1, 70-401-1, 70-402-1	–	10	16-782IDC
Extruded Aluminum DIN Rail, 39.37" (1000 mm) 6	Quick installation and removal of sockets	70-782D8-1A, 70-459-1	–	10	16-700DIN
DIN Rail End Clip 6	Holds sockets firmly in place on DIN rail	70-782D8-1A, 70-459-1	–	10	16-DCLIP-1
Small Socket Module	Protection Diode (Protects external drive circuitry from inductive voltages)	70-782D8-1A	6 to 250 Vdc	10	70-BSMD-250
Small Socket Module 7	LED Indicator (Provides coil status at a glance)		24 Vac/Vdc	10	70-BSMLG-24
Small Socket Module	MOV Suppressor (Protects from damaging electrical spikes)		120 Vac/Vdc	10	70-BSMM-120
			24 Vac/Vdc	10	70-BSMM-24
			240 Vac/Vdc	10	70-BSMM-240

Note: Use of LED socket module may increase coil power draw by up to 10%.

Description

Magnecraft General Purpose Relays

783 Series

3PDT 15 A



UL listed when used with proper Magnecraft sockets



783 Clear Cover



783 Full-Feature Cover

Description

The 783 Series plug-in relays offer clear or full-feature covers with multiple mounting options and accessories.

Feature	Benefit
15 A max. switching current	Ideal for automation panels and controls
Clear or full-feature cover options	Full-feature covers include LED indicator and locking test button
3PDT contact configuration	Simultaneously control up to 3 separate circuits
Socket mount option	Simplifies installation and maintenance while also allowing the use of protection modules, hold-down clips and other accessories
Gold-flashed contacts	Reduces contact oxidation and increases shelf life
Mechanical flag indicator	Standard feature displays relay status during testing or operation

Contact Rating	Contact Configuration	Nominal Voltage	Coil Resistance (Ω)	Standard Part Number: Clear Cover	Standard Part Number: Full-Feature
15 A	3PDT	24 Vac 50/60 Hz	103	783XCXC-24A	783XCXM4L-24A
		120 Vac 50/60 Hz	2770	-	783XCXM4L-120A
		12 Vdc	100	783XCXC-12D	783XCXM4L-12D
		24 Vdc	400	783XCXC-24D	783XCXM4L-24D
		110 Vdc	8600	783XCXC-110D	-

Part Number Explanation

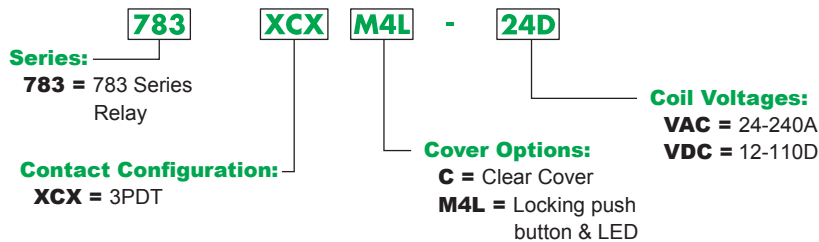

*Please note that LED-only versions are also available.
Please contact Customer Service for more information (847-441-2540).

Specifications (UL 508)

Part Number	783XCX
Contact Characteristics	
Terminal Style	Blade
Contact Configuration	3PDT
Maximum Current per Pole	15 A
Maximum Current for Product (all poles)	30 A up to 120 Vac, 28 Vdc total; 20 A from 150 Vac to 277 Vac total; 2 hp Maximum total
Contact Materials	Silver Alloy
Maximum Switching Voltage	300 V
Rated Switching Current at Voltage	Resistive: 12 A at 277 Vac 50/60 Hz; 15 A at 120 Vac 50/60 Hz; 12 A at 28 Vdc Motor: 1/2 hp at 120 Vac 50/60 Hz; 3/4 hp at 250 Vac 50/60 Hz Pilot Duty: B300
Minimum Switching Requirement	100 mA at 5 Vdc (0.5 W)
Coil Characteristics	
Maximum Operating Voltage	110% (AC / DC)
Maximum Pickup Voltage	85% (AC); 80% (DC)
Drop-out Voltage Threshold	15% (AC); 10% (DC)
Average Consumption	1.7 VA (AC); 1.7 W (DC)
General Characteristics	
Electrical Life at Rated Load	200,000 operations
Mechanical Life (Unpowered)	10,000,000 operations
Operating Time (Response Time)	20 ms
Dielectric Strength - Between Coil and Contact (AC)	2000 V(rms)
Dielectric Strength - Between Poles (AC)	2000 V(rms)
Dielectric Strength - Between Contacts (AC)	1500 V(rms)
Ambient Air Temperature around the Device - Storage	-40 – +85 °C (-40 – +185 °F)
Ambient Air Temperature around the Device - Operation	-40 – +55 °C (-40 – +131 °F)
Vibration Resistance - Operational	+/- 1 mm (10–35 Hz) and 3 g-n (35–150 Hz)
Shock Resistance	10 g-n
Degree of Protection	IP 40
Weight	60 g (2.12 oz)
Agency Approvals	UL with socket, UR (E43641), CE, CSA (225619), RoHS

Note: Actual product performance may vary depending on application and environmental conditions.

Dimensions — inches (millimeters)

Clear Cover Dimensions

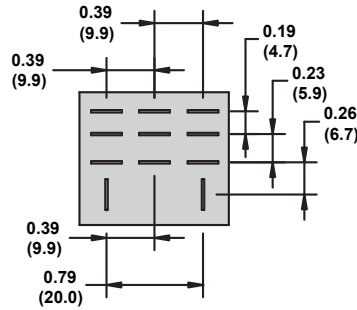
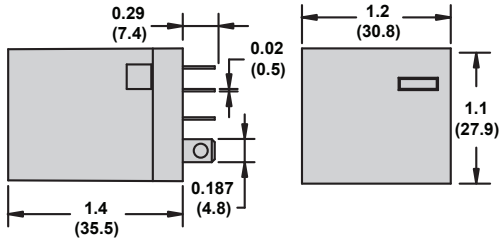

Full-Feature Cover Dimensions

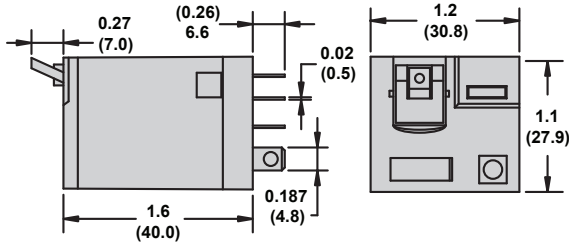

Wiring Diagram

3PDT

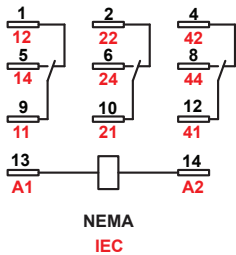

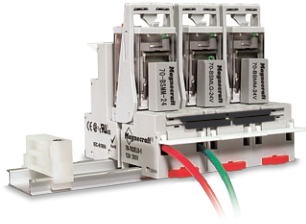

Description

Optional sockets offer customizable, Fingersafe solutions including protection modules, hold-down clips, and ID tags. Sockets are DIN rail and panel mount compatible.

Relay Accessories

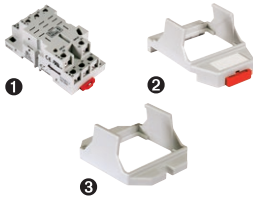

Description	Function	For Use With Relays	Pkg. Min.	Standard Part Number
Socket ①	Fingersafe, DIN/Panel mount with screw terminals and clamping plates	783	10	70-783D11-1A
Adapter ②	Mount directly to DIN rail		10	16-783C
Adapter ③	Mount directly to panel		10	16-783C1

Socket Accessories



Description	Function	For Use With Sockets	Coil Voltage	Pkg. Min.	Standard Part Number
Metal Spring Clip ①	Secures relay in socket	70-783D11-1A	–	10	16-783SC
Plastic ID Hold-Down Clip ②	Secures relay in socket and provides labeling		–	10	16-783IDC
Extruded Aluminum DIN Rail, 39.37" (1000 mm) ③	Quick installation and removal of sockets		–	10	16-700DIN
DIN Rail End Clip ③	Holds sockets firmly in place on DIN rail	–	–	10	16-DCLIP-1
Large Socket Module	MOV Suppressor (<i>Protects from damaging electrical spikes</i>)	70-783D11-1A	24 Vac/Vdc	10	70-ASMM-24
Large Socket Module	Protection Diode (<i>Protects external drive circuitry from inductive voltages</i>)		250 Vdc	10	70-ASMD-250
Large Socket Module ④	LED Indicator (<i>Provides coil status at a glance</i>)		110/240 Vac/Vdc	10	70-ASMLG-110/240
Large Socket Module	RC Suppressor (<i>Snubs back EMF of relay coil</i>)		110/240 Vac	10	70-ASMR-110/240

Note: Use of LED or RC socket module may increase coil power draw by up to 10%.

Description

Magnecraft General Purpose Relays

784 Series

4PDT 15 A



UL listed when used with proper Magnecraft sockets



784 Clear Cover

784 Full-Feature Cover

Description

The 784 Series plug-in relays offer clear or full-feature covers with multiple mounting options and accessories.

Feature	Benefit
15 A max. switching current	Ideal for automation panels and controls
Clear or full-feature cover options	Full-feature covers include LED indicator and locking test button
4PDT contact configuration	Simultaneously control up to 4 separate circuits
Socket mount option	Simplifies installation and maintenance while also allowing the use of protection modules, hold-down clips and other accessories
Gold-flashed contacts	Reduces contact oxidation and increases shelf life
Mechanical flag indicator	Standard feature displays relay status during testing or operation

Contact Rating	Contact Configuration	Nominal Voltage	Coil Resistance (Ω)	Standard Part Number: Clear Cover	Standard Part Number: Full-Feature
15 A	4PDT	24 Vac 50/60 Hz	84.5	784XDXC-24A	784XDXM4L-24A
		120 Vac 50/60 Hz	2220	784XDXC-120A	784XDXM4L-120A
		12 Vdc	96	–	784XDXM4L-12D
		24 Vdc	388	784XDXC-24D	784XDXM4L-24D

Part Number Explanation

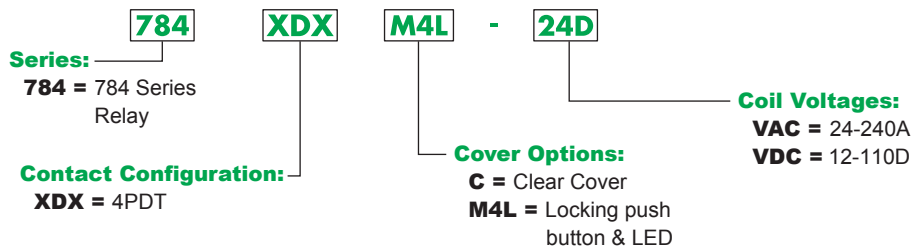

*Please note that LED-only versions are also available.
 Please contact Customer Service for more information (847-441-2540).

Specifications (UL 508)

Part Number	784XDX
Contact Characteristics	
Terminal Style	Blade
Contact Configuration	4PDT
Maximum Current per Pole	15 A
Maximum Current for Product (all poles)	30 A up to 120 Vac, 28 Vdc total; 20 A from 150 Vac to 277 Vac total; 2 hp Maximum total
Contact Materials	Silver Alloy
Maximum Switching Voltage	300 V
Rated Switching Current at Voltage	Resistive: 12 A at 277 Vac 50/60 Hz; 15 A at 120 Vac 50/60 Hz; 12 A at 28 Vdc Motor: 1/2 hp at 120 Vac 50/60 Hz; 3/4 hp at 250 Vac 50/60 Hz Pilot Duty: B300
Minimum Switching Requirement	100 mA at 5 Vdc (0.5 W)
Coil Characteristics	
Maximum Operating Voltage	110% (AC / DC)
Maximum Pickup Voltage	85% (AC); 80% (DC)
Drop-out Voltage Threshold	15% (AC); 10% (DC)
Average Consumption	2.9 VA (AC); 2.0 W (DC)
General Characteristics	
Electrical Life at Rated Load	200,000 operations
Mechanical Life (Unpowered)	10,000,000 operations
Operating Time (Response Time)	20 ms
Dielectric Strength - Between Coil and Contact (AC)	2000 V(rms)
Dielectric Strength - Between Poles (AC)	2000 V(rms)
Dielectric Strength - Between Contacts (AC)	1500 V(rms)
Ambient Air Temperature around the Device - Storage	-40 – +85 °C (-40 – +185 °F)
Ambient Air Temperature around the Device - Operation	-40 – +55 °C (-40 – +131 °F)
Vibration Resistance - Operational	+/- 1 mm (10–35 Hz) and 3 g-n (35–150 Hz)
Shock Resistance	15 g-n
Degree of Protection	IP 40
Weight	80 g (2.82 oz)
Agency Approvals	UL with socket, UR (E43641), CE, CSA (225619), RoHS

Note: Actual product performance may vary depending on application and environmental conditions.

Dimensions — inches (millimeters)

Clear Cover Dimensions

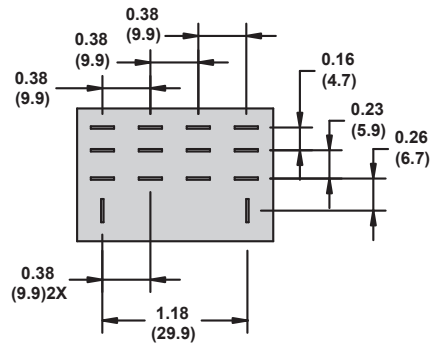
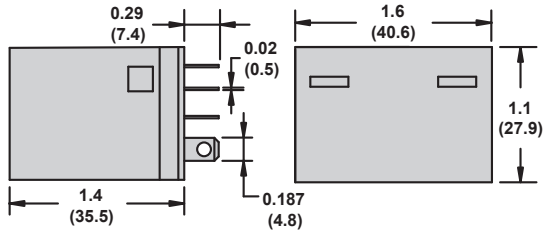

Full-Feature Cover Dimensions

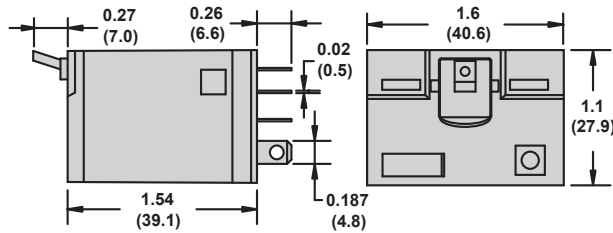

Wiring Diagram

4PDT

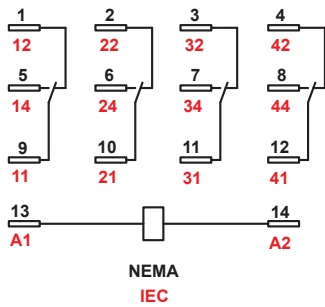

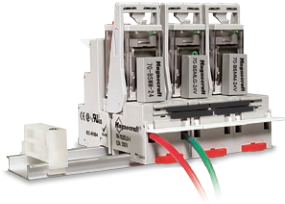

Description

Optional sockets offer customizable, Fingersafe solutions including protection modules, hold-down clips, and ID tags. Sockets are DIN rail and panel mount compatible.

Relay Accessories

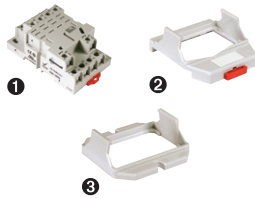

Description	Function	For Use With Relays	Pkg. Min.	Standard Part Number
Socket ①	Fingersafe, DIN/Panel mount with screw terminals and clamping plates	784	10	70-784D14-1
Adapter ②	DIN rail adapter	784	10	16-784C
Adapter ③	Flange mount adapter	784	10	16-784C1

Socket Accessories

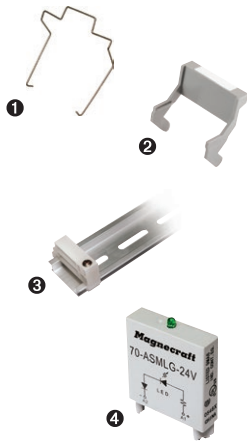

Description	Function	For Use With Socket	Coil Voltage	Pkg. Min.	Standard Part Number
Metal Spring Clip ①	Secures relay in socket	70-784D14-1	–	10	16-784SC
Plastic ID Hold-Down Clip ②	Secures relay in socket and provides labeling		–	10	16-784IDC
Extruded Aluminum DIN Rail, 39.37" (1000 mm) ③	Quick installation and removal of sockets		–	10	16-700DIN
DIN Rail End Clip ③	Holds sockets firmly in place on DIN rail	–	–	10	16-DCLIP-1
Large Socket Module	MOV Suppressor (<i>Protects from damaging electrical spikes</i>)	70-784D14-1	24 Vac/Vdc	10	70-ASMM-24
Large Socket Module	Protection Diode (<i>Protects external drive circuitry from inductive voltages</i>)		250 Vdc	10	70-ASMD-250
Large Socket Module ④	LED Indicator (<i>Provides coil status at a glance</i>)		110/240 Vac/Vdc	10	70-ASMLG-110/240
Large Socket Module	RC Suppressor (<i>Snubs back EMF of relay coil</i>)		110/240 Vac	10	70-ASMR-110/240

Note: Use of LED or RC socket module may increase coil power draw by up to 10%.

Description

Magnecraft General Purpose Relays

750 Series

DPDT and 3DPT, 10 A



UL listed when used with proper Magnecraft sockets



750 Clear Cover



750 Full-Feature Cover

Description

The 750 series octal base, plug-in relays offer clear or full-feature covers with multiple mounting options and accessories.

Feature	Benefit
Octal style mounting	Robust and historically-proven mounting platform that provides excellent structural support
10 A max. switching current	Ideal for automation panels and controls
Clear or full-feature cover options	Full-feature covers include LED indicator and locking test button
DPDT and 3PDT contact configurations	Simultaneously control separate circuits
Socket mount option	Simplifies installation and maintenance while also allowing the use of protection modules, hold-down clips and other accessories
Gold-flashed contacts	Reduces contact oxidation and increases shelf life
Mechanical flag indicator	Standard feature displays relay status during testing or operation

Contact Configuration	Contact Rating	Nominal Voltage	Coil Resistance (Ω)	Standard Part Number: Clear Cover	Standard Part Number: Full-Feature
DPDT	10 A	24 Vac 50/60 Hz	72	750XBXRC-24A	750XBXRM4L-24A
		120 Vac 50/60 Hz	1700	750XBXRC-120A	750XBXRM4L-120A
		240 Vac 50/60 Hz	6800	750XBXRC-240A	750XBXRM4L-240A
		12 Vdc	120	750XBXRC-12D	750XBXRM4L-12D
		24 Vdc	470	750XBXRC-24D	750XBXRM4L-24D
		110 Vdc	7300	750XBXRC-110D	750XBXRM4L-110D
3PDT	10 A	24 Vac 50/60 Hz	72	750XCXRC-24A	750XCXRM4L-24A
		120 Vac 50/60 Hz	1700	750XCXRC-120A	750XCXRM4L-120A
		12 Vdc	120	750XCXRC-12D	750XCXRM4L-12D
		24 Vdc	470	750XCXRC-24D	750XCXRM4L-24D
		110 Vdc	7300	750XCXRC-110D	750XCXRM4L-110D

Part Number Explanation

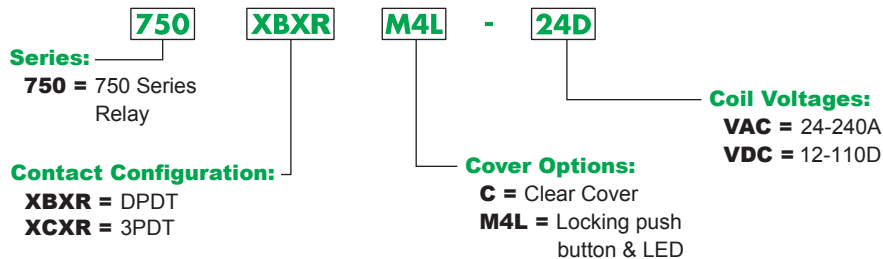

*Please note that LED-only versions are also available.
Please contact Customer Service for more information (847-441-2540).

Specifications (UL 508)

Part Number	750XBXR	750XCXR
Contact Characteristics		
Terminal Style	Octal	Octal
Contact Configuration	DPDT	3PDT
Maximum Current	10 A	10 A
Contact Materials	Silver Alloy	Silver Alloy
Maximum Switching Voltage	300 V	300 V
Rated Switching Current at Voltage	Resistive: 10 A at 277 Vac 50/60 Hz; 10 A at 30 Vdc Motor: 1/3 hp at 120 Vac; 1 hp at 277 Vac Pilot Duty: B300	Resistive: 10 A at 277 Vac 50/60 Hz; 10 A at 30 Vdc Motor: 1/3 hp at 120 Vac; 1 hp at 277 Vac Pilot Duty: B300
Minimum Switching Requirement	10 mA at 17 Vdc	10 mA at 17 Vdc
Coil Characteristics		
Maximum Operating Voltage	110% (AC / DC)	110% (AC / DC)
Maximum Pickup Voltage	85% (AC); 80% (DC)	85% (AC); 80% (DC)
Drop-out Voltage Threshold	15% (AC); 10% (DC)	15% (AC); 10% (DC)
Average Consumption	3 VA (AC); 1.4 W (DC)	3 VA (AC); 1.4 W (DC)
General Characteristics		
Electrical Life at Rated Load	100,000 operations	100,000 operations
Mechanical Life	5,000,000 operations	5,000,000 operations
Operating Time (Response Time)	20 ms	20 ms
Dielectric Strength - Between Coil and Contact (AC)	2500 V(rms)	2500 V(rms)
Dielectric Strength - Between Poles (AC)	2000 V(rms)	2000 V(rms)
Ambient Air Temperature around the Device - Storage	-40 – +85 °C (-40 – +185°F)	-40 – +85 °C (-40 – +185 °F)
Ambient Air Temperature around the Device - Operation	-40 – +55 °C (-40 – +131°F)	-40 – +55 °C (-40 – +131 °F)
Vibration Resistance - Operational	+/- 1 mm (10–35 Hz) and 3 g-n (35–150 Hz)	+/- 1 mm (10–35 Hz) and 3 g-n (35–150 Hz)
Shock Resistance	10 g-n	10 g-n
Degree of Protection	IP 40	IP 40
Weight	83 g (2.93 oz)	83 g (2.93 oz)
Agency Approvals	UL with socket, UR (E48539), CE, CSA (225619), RoHS	

Note: Actual product performance may vary depending on application and environmental conditions.

Dimensions — inches (millimeters)

Clear Cover Dimensions

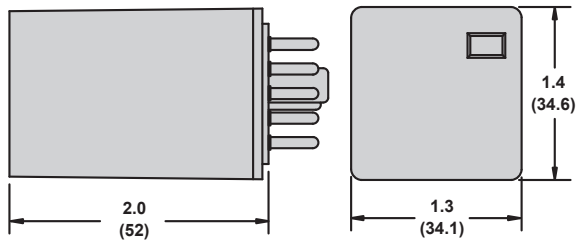

Full-Feature Cover Dimensions

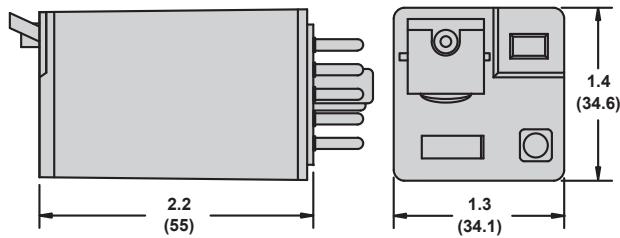

Wiring Diagrams

DPDT

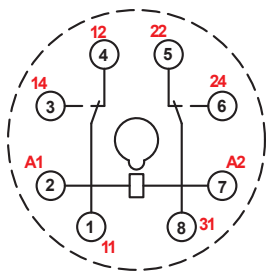

3DPT

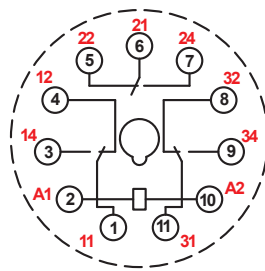

NEMA
IEC

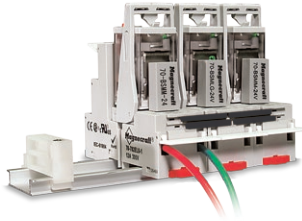

Description

Optional sockets offer customizable, Fingersafe solutions including protection modules, hold-down clips, and ID tags. Sockets are DIN rail and panel mount compatible.

Relay Accessories

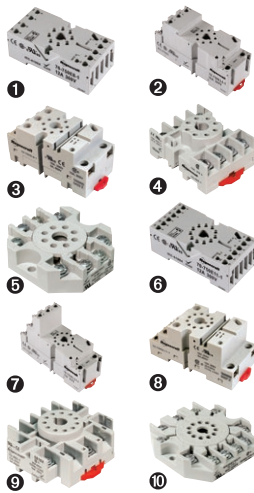

Description	Function	For Use With Relays	Pkg. Min.	Standard Part Number
Socket 1	DIN/Panel mount, module compatible	750XBXR	10	70-750E8-1
Socket 2	DIN/Panel mount with elevator terminals, module compatible	750XBXR	10	70-750EL8-1
Socket 3	DIN/Panel mount, module compatible	750XBXR	10	70-750DL8-1
Socket 4	DIN/Panel mount with screw terminals and clamping plates	750XBXR	10	70-464-1
Socket 5	Panel mount with screw terminals and clamping plates	750XBXR	10	70-169-1
Socket 6	DIN/Panel mount with elevator terminals, module compatible	750XCXR	10	70-750E11-1
Socket 7	DIN/Panel mount with elevator terminals	750XCXR	10	70-750EL11-1
Socket 8	DIN/Panel mount, module compatible	750XCXR	10	70-750DL11-1
Socket 9	DIN/Panel mount with screw terminals and clamping plates	750XCXR	10	70-465-1
Socket 10	Panel mount with screw terminals and clamping plates	750XCXR	10	70-170-1

Socket Accessories

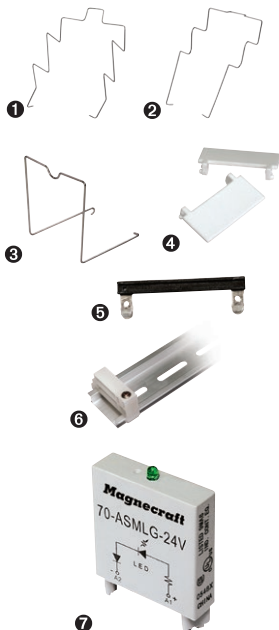

Description	Function	For Use With Sockets	Coil Voltage	Pkg. Min.	Standard Part Number
Metal Spring Clip 1	Secures relay in socket	70-750EL8-1, 70-750E8-1, 70-750E11-1, 70-464-1	–	10	16-1351
Metal Spring Clip 2	Secures relay in socket	70-750E8-1, 70-750DL8-1, 70-750E11-1, 70-464-1	–	10	16-1344
Metal Spring Clip 3	Secures relay in socket	70-750DL8-1	–	10	16-1332
Plastic I.D. Tag 4	Write-on plastic labels	70-750E8-1, 70-750EL8-1, 70-750DL8-1, 70-750E11-1, 70-750EL11, 70-750DL11-1	–	10	16-750/788FT-1
Insulated Coil Bus Jumper System 5	Wireless socket connection	70-750E8-1, 70-750EL8-1, 70-750DL8-1, 70-750E11-1, 70-464-1, 70-465-1	–	10	16-750/788CBJ-1
Extruded Aluminum DIN Rail, 39.37" (1000 mm) 6	Quick installation and removal of sockets	–	–	10	16-700DIN
DIN Rail End Clip 6	Plastic end clip with locking screw	–	–	10	16-DCLIP-1
Large Socket Module	MOV Suppressor (Protects from damaging electrical spikes)	70-750E8-1, 70-750EL8-1, 70-750DL8-1, 70-750E11-1, 70-750DL11-1	24 Vac/Vdc	10	70-ASMM-24
Large Socket Module	Protection Diode (Protects external drive circuitry from inductive voltages)	70-750E8-1, 70-750EL8-1, 70-750DL8-1, 70-750E11-1, 70-750DL11-1	250 Vdc	10	70-ASMD-250
Large Socket Module 7	LED Indicator (Provides coil status at a glance)	70-750E8-1, 70-750EL8-1, 70-750DL8-1, 70-750E11-1, 70-750DL11-1	110/240 Vac/Vdc	10	70-ASMLG-110/240
Large Socket Module	RC Suppressor (Snubs back EMF of relay coil)	70-750E8-1, 70-750EL8-1, 70-750DL8-1, 70-750E11-1, 70-750DL11-1	110/240 Vac	10	70-ASMR-110/240

Note: Use of LED or RC socket module may increase coil power draw by up to 10%.

Description

Magnecraft General Purpose Relays

788 Series

DPDT and 3PDT 10 A



UL listed when used with proper Magnecraft sockets



788 Clear Cover



788 Full-Feature Cover

Description

The 788 Series square base, plug-in relays offer clear, full-feature, top flange, and side flange covers as well as optional sockets and accessories.

Feature	Benefit
10 A max. switching current	Ideal for automation panels and controls
Clear or full-feature cover options	Full-feature covers include LED indicator and locking test button
DPDT and 3PDT contact configurations	Simultaneously control separate circuits
Socket mount option	Simplifies installation and maintenance while also allowing the use of protection modules, hold-down clips and other accessories
Gold-flashed contacts	Reduces contact oxidation and increases shelf life
Mechanical flag indicator	Standard feature displays relay status during testing or operation

Contact Rating	Contact Configuration	Nominal Voltage	Coil Resistance (Ω)	Feature	Standard Part Number: Clear Cover	Standard Part Number: Full-Feature
10 A	DPDT	24 Vac 50/60 Hz	72	–	788XBXRC-24A	788XBXRM4L-24A
		120 Vac 50/60 Hz	1700	–	788XBXRC-120A	788XBXRM4L-120A
		12 Vdc	120	–	788XBXRC1-120A	–
				Flange Mount	788XBXRC-12D	788XBXRM4L-12D
		24 Vdc	470	–	788XBXRC-24D	788XBXRM4L-24D
	Flange Mount			788XBXRC1-24D	–	
	110 Vdc	7300	–	788XBXRC-110D	–	
	3PDT	24 Vac 50/60 Hz	72	–	788XCXRC-24A	788XCXRM4L-24A
		120 Vac 50/60 Hz	1700	–	788XCXRC-120A	788XCXRM4L-120A
		12 Vdc	120	–	788XCXRC-12D	788XCXRM4L-12D
24 Vdc		470	–	788XCXRC-24D	788XCXRM4L-24D	
110 Vdc		7300	–	–	788XCXRM4L-110D	
3 A at 150 Vdc	DPDT	120 Vac 50/60 Hz	1700	Blowout magnet	788XBXR69C-120A	–
		24 Vdc	470		788XBXR69C-24D	–

Part Number Explanation

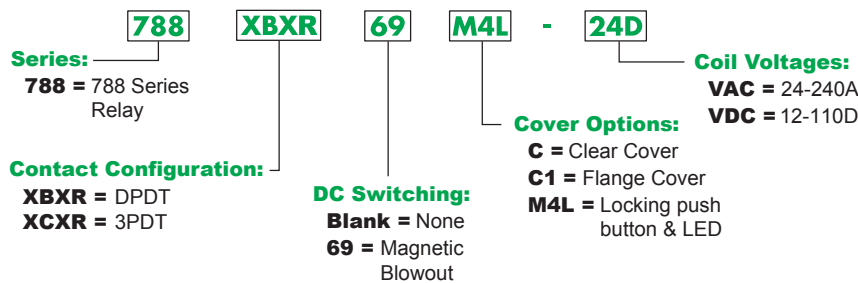

*Please note that LED-only versions are also available. Please contact Customer Service for more information (847-441-2540).

Specifications (UL 508)

Part Number	788XBXR/XCXR
Contact Characteristics	
Terminal Style	Blade
Contact Configuration	DPDT/3PDT
Maximum Current	10 A
Contact Materials	Silver Alloy
Maximum Switching Voltage	300 V
Rated Switching Current at Voltage	Resistive: 10 A at 277 Vac 50/60 Hz; 10 A at 30 Vdc Motor: 1/3 hp at 120 Vac; 1 hp at 277 Vac Pilot Duty: B300
Rated Current with Magnetic Blowout (Code 69)	3 A at 150 Vdc (DPDT only)
Minimum Switching Requirement	10 mA at 17 Vdc
Coil Characteristics	
Maximum Operating Voltage	110% (AC / DC)
Maximum Pickup Voltage	85% (AC); 80% (DC)
Drop-out Voltage Threshold	15% (AC); 10% (DC)
Average Consumption	3 VA (AC); 1.4 W (DC)
General Characteristics	
Electrical Life at Rated Load	100,000 operations
Mechanical Life (Unpowered)	5,000,000 operations
Operating Time (Response Time)	20 ms
Dielectric Strength - Between Coil and Contact (AC)	2500 V(rms)
Dielectric Strength - Between Poles (AC)	2000 V(rms)
Ambient Air Temperature around the Device - Storage	-40 – +85 °C (-40 – +185 °F)
Ambient Air Temperature around the Device - Operation	-40 – +55 °C (-40 – +131 °F)
Vibration Resistance - Operational	+/- 1 mm (10–35 Hz) and 3 g-n (35–150 Hz)
Shock Resistance	10 g-n
Degree of Protection	IP 40
Weight	83 g (2.93 oz)
Agency Approvals	UL with socket, UR (E48539), CE, CSA (225619), RoHS

Note: Actual product performance may vary depending on application and environmental conditions.

Dimensions — inches (millimeters)

Plain Cover Dimensions

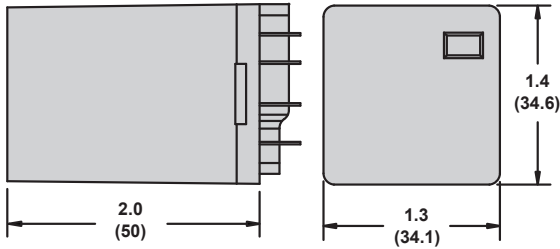

Full-Feature Cover Dimensions

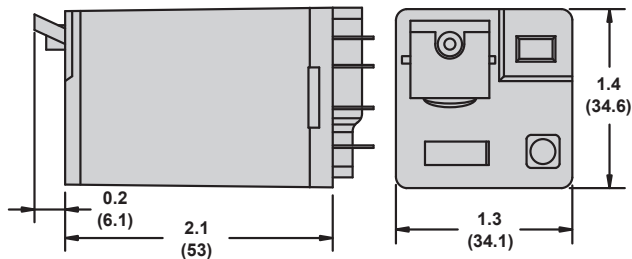

Top Flange Cover Dimensions - Code C1

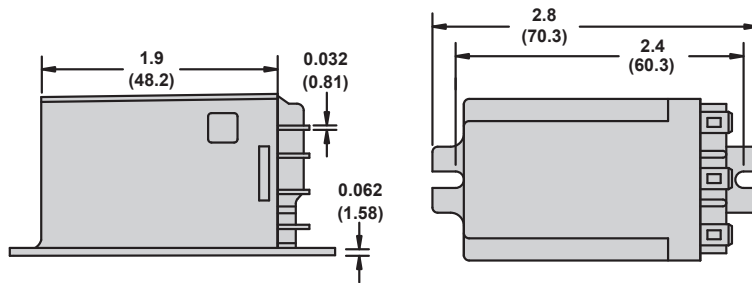

Wiring Diagrams

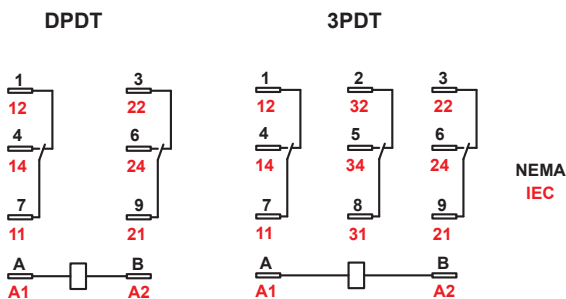

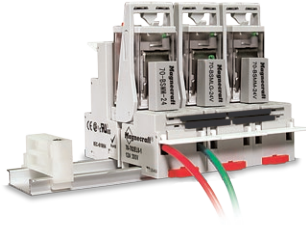

Description

Optional sockets offer customizable, Fingersafe solutions including protection modules, hold-down clips, and ID tags. Sockets are DIN rail and panel mount compatible.

Relay Accessories

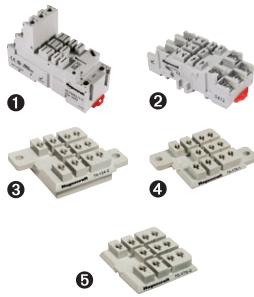

Description	Function	For Use With Relays	Pkg. Min.	Standard Part Number
Socket 1	DIN mount with elevator terminals	788XBXR/XCXR	10	70-788EL11-1
Socket 2	DIN/Panel mount with screw terminals and clamping plates		10	70-463-1
Socket 3	0.187 in. Quick Connect terminals with mounting tabs		10	70-124-2
Socket 4	Printed circuit terminals with mounting tabs		10	70-178-1
Socket 5	Printed circuit terminals without mounting tabs		10	70-178-2

Socket Accessories



Description	Function	For Use With Sockets	Coil Voltage	Pkg. Min.	Standard Part Number
Metal Spring Clip 1	Secures relay in socket	70-788EL11-1, 70-463-1, 70-124-1, 70-178-1, 70-178-2	–	10	16-1351
Metal Spring Clip 2	Secures relay in socket	70-463-1	–	10	16-1344
Insulated Coil Bus Jumper System 3	Wireless socket connection	70-788EL11-1	–	10	16-750/788CBJ-1
Plastic I.D. Tag 4	Write-on plastic labels	70-788EL11-1	–	10	16-750/788FT-1
Extruded Aluminum DIN Rail, 39.37" (1000 mm) 5	Quick installation and removal of sockets	70-788EL11-1, 70-463-1	–	10	16-700DIN
DIN Rail End Clip 6	Holds sockets firmly in place on DIN rail	–	–	10	16-DCLIP-1
Large Socket Module	MOV Suppressor (Protects from damaging electrical spikes)	70-788EL11-1	24 Vac/Vdc	10	70-ASMM-24
Large Socket Module	Protection Diode (Protects external drive circuitry from inductive voltages)		250 Vdc	10	70-ASMD-250
Large Socket Module 8	LED Indicator (Provides coil status at a glance)		110/240 Vac/Vdc	10	70-ASMLG-110/240
Large Socket Module	RC Suppressor (Snubs back EMF of relay coil)		110/240 Vac	10	70-ASMR-110/240

Note: Use of LED or RC socket module may increase coil power draw by up to 10%.

Magnecraft General Purpose Relays

782H Hazardous Location Series

4PDT 3 A and 5 A

Specifications (UL 508)

Part Number	782XDXH21	782XDXH10
Contact Characteristics		
Terminal Style	Blade	Blade
Contact Configuration	4PDT	4PDT
Maximum Current	5 A	3 A
Load Type	Standard	Low Level
Contact Materials	Silver Alloy	Fine Silver
Maximum Switching Voltage	300 V	300 V
Rated Switching Current at Voltage	Resistive: 5 A at 120 Vac 50/60 Hz; 5 A at 240 Vac 50/60 Hz; 5 A at 30 Vdc	Resistive: 3 A at 120 Vac 50/60 Hz; 3 A at 240 Vac 50/60 Hz; 3 A at 30 Vdc Motor: 1/10 hp at 240 Vac 50/60 Hz; 1/10 hp at 120 Vac 50/60 Hz
Minimum Switching Requirement	100 mA at 5 Vdc (0.5 W)	10 mA at 5 Vdc (0.5 W)
Coil Characteristics		
Maximum Operating Voltage	110% (AC / DC)	110% (AC / DC)
Maximum Pickup Voltage	85% (AC); 80% (DC)	85% (AC); 80% (DC)
Drop-out Voltage Threshold	15% (AC); 10% (DC)	15% (AC); 10% (DC)
Average Consumption	1.2 VA (AC); 0.9 W (DC)	1.2 VA (AC); 0.9 W (DC)
General Characteristics		
Electrical Life at Rated Load	100,000 operations	100,000 operations
Mechanical Life (Unpowered)	10,000,000 operations	10,000,000 operations
Operating Time (Response Time)	20 ms	20 ms
Dielectric Strength - Between Coil and Contact (AC)	1240 V(rms)	1240 V(rms)
Dielectric Strength - Between Poles (AC)	1240 V(rms)	1240 V(rms)
Ambient Air Temperature around the Device - Storage	-40 – +85 °C (-40 – +185 °F)	-40 – +85 °C (-40 – +185 °F)
Ambient Air Temperature around the Device - Operation	-40 – +70 °C (-40 – +158 °F)	-40 – +70 °C (-40 – +158 °F)
Vibration Resistance - Operational	3 g-n at 10-55 Hz	3 g-n at 10-55 Hz
Shock Resistance	10 g-n	10 g-n
Degree of Protection	IP 67	IP 67
Weight	45 g (1.59 oz)	45 g (1.59 oz)
Agency Approvals	UL with socket, UR (E209950), CE, CSA (LR40787), RoHS	UL with socket, UR (E209950), CE, CSA (LR40787), RoHS

Note: Actual product performance may vary depending on application and environmental conditions.

Dimensions — inches (millimeters)

782H

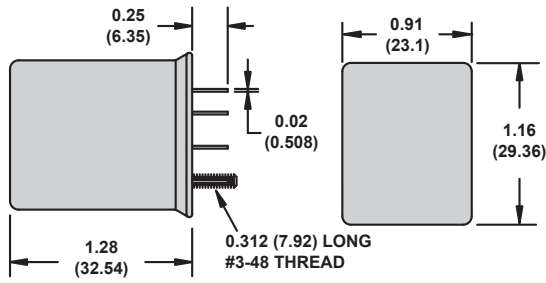

Wiring Diagrams

4PDT

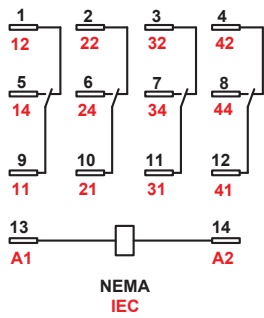

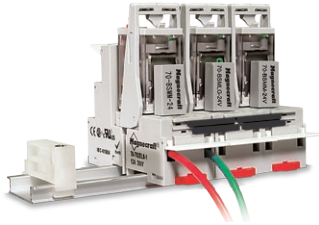

Description

Optional sockets offer customizable, Fingersafe solutions including protection modules, hold-down clips, and ID tags. Sockets are DIN rail and panel mount compatible.

Relay Accessories

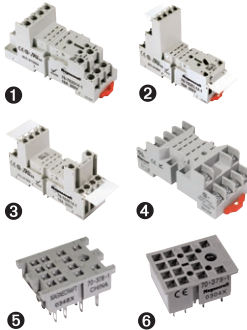

Description	Function	For Use With Relays	Pkg. Min.	Standard Part Number
Socket 1	DIN/Panel mount with screw terminals and clamping plates	782XDXH	10	70-782D14-1
Socket 2	DIN/Panel mount with elevator terminals	782XDXH	10	70-782EL14-1
Socket 3	DIN/Panel mount with rising elevator box terminals	782XDXH	10	70-782E14-1
Socket 4	DIN/Panel mount with screw terminals and clamping plates	782XDXH	10	70-461-1
Socket 5	Solder Terminals for Chassis Mount	782XDXH	10	70-378-1
Socket 6	Printed circuit terminals for PCB mount	782XDXH	10	70-379-1

Socket Accessories



Description	Function	For Use With Sockets	Coil Voltage	Pkg. Min.	Standard Part Number
Metal Spring Clip 1	Secures relay in socket	70-782D14-1, 70-782E14-1, 70-782EL14-1, 70-461-1, 70-378-1, 70-379-1	-	10	16-1342
Plastic I.D. Tag 2	Write-on plastic labels	70-782E14-1, 70-782EL14-1	-	10	16-782FT-1
Insulated Coil Bus Jumper System 3	Wireless socket connection	70-782EL14-1	-	10	16-782CBJ-1
Extruded Aluminum DIN Rail, 39.37" (1000 mm) 4	Quick installation and removal of sockets	70-782D14-1, 70-782EL14-1, 70-782E14-1	-	10	16-700DIN
DIN Rail End Clip 4	Holds sockets firmly in place on DIN rail	-	-	10	16-DCLIP-1
Small Socket Module	Protection Diode (Protects external drive circuitry from inductive voltages)	70-782D14-1, 70-782EL14-1, 70-782E14-1	6 to 250 Vdc	10	70-BSMD-250
Small Socket Module 5	LED Indicator (Provides coil status at a glance)		24 Vac/Vdc	10	70-BSMLG-24
Small Socket Module	MOV Suppressor (Protects from damaging electrical spikes)		120 Vac/Vdc	10	70-BSMM-120
			24 Vac/Vdc	10	70-BSMM-24
			240 Vac/Vdc	10	70-BSMM-240

Note: Use of LED socket module may increase coil power draw by up to 10%.

Description

Magnecraft General Purpose Relays

750H Hazardous Location Series

DPDT, 3PDT 12 A



UL listed when used with proper Magnecraft sockets



750H Hazardous Location Relay

Description

The hermetically sealed 750H Series relays comply with UL Class I Division 2 requirements for use in hazardous locations.

Feature	Benefit
Hermetically sealed	Complies with UL Class I Division 2 for Hazardous Locations Groups A, B, C, and D; sealed for wash down conditions
Octal style mounting	Robust and historically-proven mounting platform that provides excellent structural support
12 A max. switching current	Ideal for automation and control applications
DPDT and 3PDT contact configuration	Simultaneously control separate circuits
Socket mount option	Simplifies installation and maintenance while also allowing the use of protection modules, hold-down clips and other accessories

Contact Rating	Contact Configuration	Nominal Voltage	Coil Resistance (Ω)	Standard Part Number
12 A	DPDT	24 Vac 50/60 Hz	72	750XBXH-24A
		120 Vac 50/60 Hz	1700	750XBXH-120A
		12 Vdc	120	750XBXH-12D
		24 Vdc	470	750XBXH-24D
		110 Vdc	10000	750XBXH-110D
	3PDT	24 Vac 50/60 Hz	72	750XCXH-24A
		120 Vac 50/60 Hz	1700	750XCXH-120A
		24 Vdc	470	750XCXH-24D
110 Vdc		10000	750XCXH-110D	

Part Number Explanation

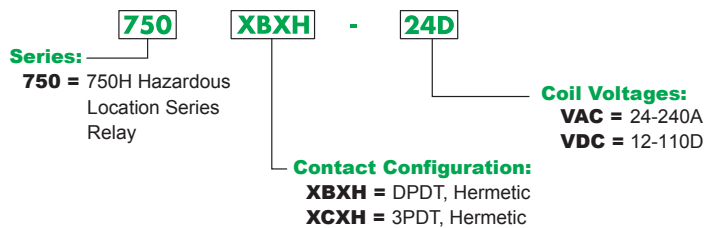

*Please note that 1A Bifurcated and 3A Silver Alloy versions are also available. Please contact Customer Service for more information (847-441-2540).

Magnecraft General Purpose Relays

750H Hazardous Location Series

DPDT, 3PDT 12 A

Specifications (UL 508)

Part Number	750XBXH	750XCXH
Contact Characteristics		
Terminal Style	Octal	Octal
Contact Configuration	DPDT	3PDT
Maximum Current	12 A	12 A
Load Type	Standard	Standard
Contact Materials	Silver Alloy	Silver Alloy
Maximum Switching Voltage	300 V	300 V
Rated Switching Current at Voltage	Resistive: 12 A at 120 Vac 50/60 Hz; 12 A at 240 Vac 50/60 Hz; 12 A at 28 Vdc Motor: 1/2 hp at 240 Vac 50/60 Hz; 1/3 hp at 120 Vac 50/60 Hz Pilot Duty: B300	Resistive: 12 A at 120 Vac 50/60 Hz; 12 A at 240 Vac 50/60 Hz; 12 A at 28 Vdc Motor: 1/2 hp at 240 Vac 50/60 Hz; 1/3 hp at 120 Vac 50/60 Hz Pilot Duty: B300
Minimum Switching Requirement	100 mA at 5 Vdc (0.5 W)	100 mA at 5 Vdc (0.5 W)
Coil Characteristics		
Maximum Operating Voltage	110% (AC / DC)	110% (AC / DC)
Maximum Pickup Voltage	85% (AC); 80% (DC)	85% (AC); 80% (DC)
Drop-out Voltage Threshold	15% (AC); 10% (DC)	15% (AC); 10% (DC)
Average Consumption	1.2 VA (AC); 0.9 W (DC)	2 VA (AC); 1.2 W (DC)
General Characteristics		
Electrical Life at Rated Load	100,000 operations	100,000 operations
Mechanical Life (Unpowered)	10,000,000 operations	10,000,000 operations
Operating Time (Response Time)	20 ms	20 ms
Dielectric Strength - Between Coil and Contact (AC)	1500 V(rms)	1500 V(rms)
Dielectric Strength - Between Poles (AC)	1500 V(rms)	1500 V(rms)
Ambient Air Temperature around the Device - Storage	-40 – +85 °C (-40 – 185 °F)	-40 – +85 °C (-40 – 185 °F)
Ambient Air Temperature around the Device - Operation	-40 – +55 °C (-40 – 131 °F)	-40 – +55 °C (-40 – 131 °F)
Vibration Resistance - Operational	3 g-n at 10-55 Hz	3 g-n at 10-55 Hz
Shock Resistance	10 g-n	10 g-n
Degree of Protection	IP 67	IP 67
Weight	130 g (4.59 oz)	130 g (4.59 oz)
Agency Approvals	UL with socket, UR (E209950), RoHS	UL with socket, UR (E209950), RoHS

Note: Actual product performance may vary depending on application and environmental conditions.

Dimensions — inches (millimeters)

750H

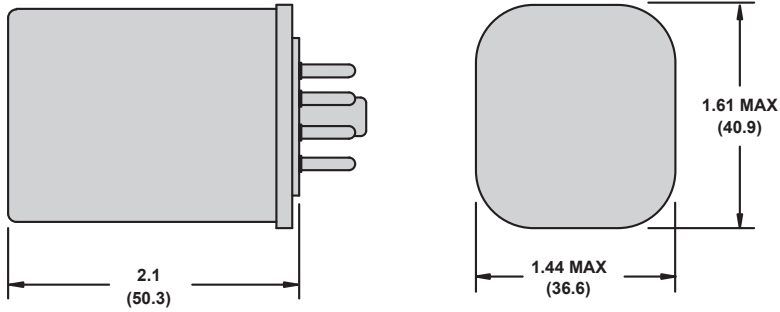

Wiring Diagrams

DPDT

3PDT

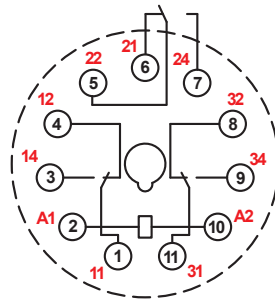
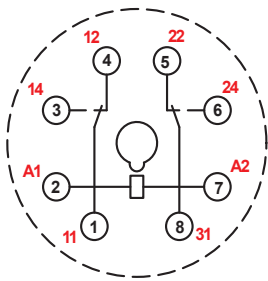

NEMA
IEC

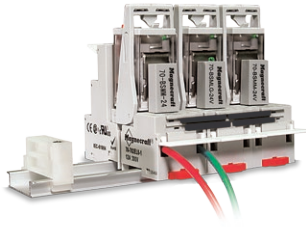

Description

Optional sockets offer customizable, Fingersafe solutions including protection modules, hold-down clips, and ID tags. Sockets are DIN rail and panel mount compatible.

Relay Accessories

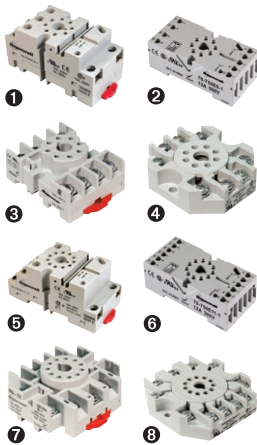

Description	Function	For Use With Relays	Pkg. Min.	Standard Part Number
Socket 1	DIN/Panel Mount with Screw Terminals	750XBXH	10	70-750DL8-1
Socket 2	DIN/Panel mount with elevator terminals, module compatible	750XBXH	10	70-750E8-1
Socket 3	DIN/Panel mount with screw terminals and clamping plates	750XBXH	10	70-464-1
Socket 4	Panel mount with screw terminals and clamping plates	750XBXH	10	70-169-1
Socket 5	DIN/Panel Mount	750XCXHX	10	70-750DL11-1
Socket 6	DIN/Panel mount with elevator terminals	750XCXHX	10	70-750E11-1
Socket 7	DIN/Panel mount with screw terminals and clamping plates	750XCXHX	10	70-465-1
Socket 8	Panel mount with screw terminals and clamping plates	750XCXHX	10	70-170-1

Socket Accessories

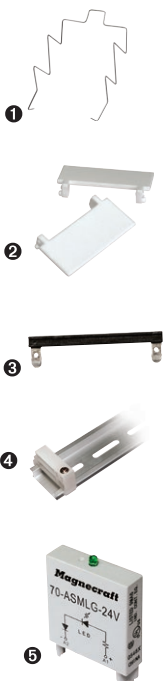

Description	Function	For Use With Sockets	Coil Voltage	Pkg. Min.	Standard Part Number
Metal Spring Clip 1	Secures relay in socket	70-750DL8-1, 70-750E8-1, 70-464-1, 70-750E11-1, 70-750DL11-1, 70-465-1	-	10	16-1351
Plastic I.D. Tag 2	Write-on plastic labels	70-750E8-1, 70-750E11-1	-	10	16-750/788FT-1
Insulated Coil Bus Jumper System 3	Wireless Socket Connection	70-750DL8-1, 70-750DL11-1	-	10	16-750/788CBJ-1
Extruded Aluminum DIN Rail, 39.37" (1000 mm) 4	Quick installation and removal of sockets	70-750DL8-1, 70-750E8-1, 70-464-1, 70-750E11-1, 70-750DL11-1, 70-465-1	-	10	16-700DIN
DIN Rail End Clip 4	Holds sockets firmly in place on DIN rail	-	-	10	16-DCLIP-1
Large Socket Module	MOV Suppressor (Protects from damaging electrical spikes)	70-750DL8-1, 70-750E8-1, 70-750E11-1, 70-750DL11-1	24 Vac/Vdc	10	70-ASMM-24
Large Socket Module	Protection Diode (Protects external drive circuitry from inductive voltages)		250 Vdc	10	70-ASMD-250
Large Socket Module 5	LED Indicator (Provides coil status at a glance)		110/240 Vac/Vdc	10	70-ASMLG-110/240
Large Socket Module	RC Suppressor (Snubs back EMF of relay coil)		110/240 Vac	10	70-ASMR-110/240

Note: Use of LED or RC socket module may increase coil power draw by up to 10%.



782XDX Relay with
70-782D14-1 Socket and
16-782SC Spring Clip

- Socket Specifications42
- Mounting Adapter Specifications65

The following relay/socket combinations comprise a UL Listed assembly when used with each other. This added benefit allows for easier installation as there are no end-use evaluations required when using Magnecraft relays or sockets with third party components.

UL Listed Relay/Socket Combinations

Mating Relay(s)	Number of Socket Pins	Socket Part Number
781	5	70-781D5-1A
782 Power	8	70-782D8-1A
		70-459-1
782 Control	8	70-782EL8-1
		70-782D14-1
	14	70-782E14-1
		70-782EL14-1
		70-461-1
783	11	70-783D11-1A
784	14	70-784D14-1
750	8	70-464-1
		70-750E8-1
		70-750EL8-1
		70-750DL8-1
	11	70-465-1
		70-750E11-1
		70-750EL11-1
		70-750DL11-1
788	11	70-463-1
		70-788EL11-1
782H	14	70-782EL14-1
		70-782E14-1
		70-782D14-1
		70-461-1
750H	8	70-464-1
		70-750E8-1
	11	70-465-1
		70-750E11-1

Socket Specifications

Part Number	70-124-2
Contact Configuration	3PDT
Number of Terminals	11
Mounting Style	Panel / Chassis
Current Rating	15 A
Nominal Voltage Rating	300 V
Storage Temperature Range	-40 – +105 °C (-40 – +221 °F)
Operating Temperature Range	-40 – +80 °C (-40 – +176 °F)
Protection Category (Fingersafe)	IP 20
Internal Metal Tracks	Copper Alloy, Zinc Plated
Screw Terminals	Copper Alloy, Zinc Plated
Screw Style	–
Screw Size	–
Maximum Screw Torque	–
Terminal Connection	Solder
Terminal Layout	Mix
Maximum Wire Size	Solid Cu: (Output) 16 AWG, 1.0 mm ² ; Stranded Cu: (Output) 16 AWG, 1.0 mm ²
DIN Rail Mounting, EN 60715	–
Chassis Mount Screw Torque	–
Flammability Rating	94V-0
Weight	12.1 g (0.43 oz)
Agency Approvals	UL (E70550), CE, CSA (LR40787), RoHS

Dimensions — inches (millimeters)

70-124-2

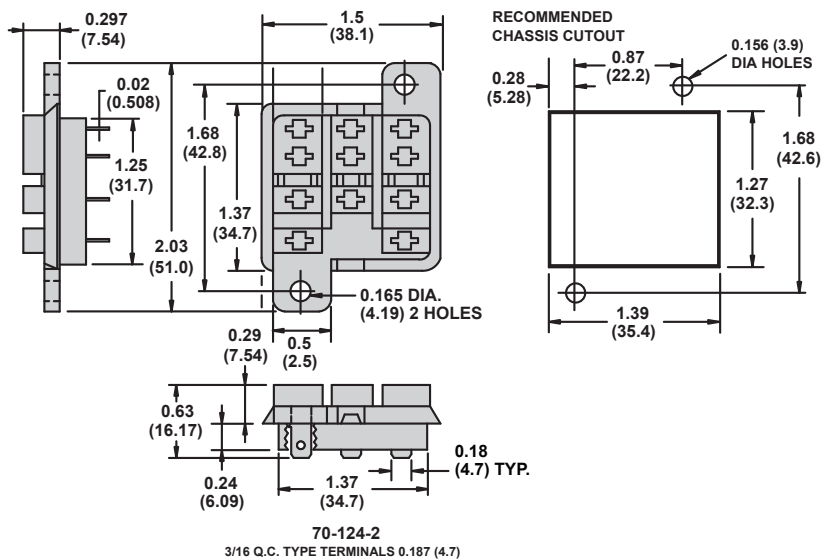

Wiring Diagram

70-124-2

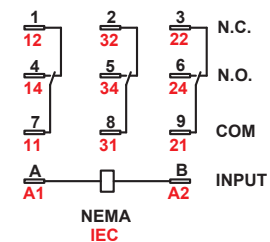

Socket Specifications

Part Number	70-169-1	70-170-1
Contact Configuration	DPDT	3PDT
Number of Terminals	8	11
Mounting Style	Panel	Panel
Current Rating	15 A	15 A
Nominal Voltage Rating	300 V	300 V
Storage Temperature Range	-40 – +105 °C (-40 – +221 °F)	-40 – +105 °C (-40 – +221 °F)
Operating Temperature Range	-40 – +80 °C (-40 – +176 °F)	-40 – +80 °C (-40 – +176 °F)
Protection Category (Fingersafe)	–	–
Internal Metal Tracks	Copper Alloy, Zinc Plated	Copper Alloy, Zinc Plated
Screw Terminals	Steel, Zinc Plated	Steel, Zinc Plated
Screw Style	Combination Head	Combination Head
Screw Size	M3.5 mm	M3.5 mm
Maximum Screw Torque	9 Lb-in / 1.0 N•m	9 Lb-in / 1.0 N•m
Terminal Connection	Screw Clamping	Screw Clamping
Terminal Layout	Mix	Mix
Maximum Wire Size	Solid Cu: 12/14 (2) AWG, 4/2.5 (2) mm ² Stranded Cu: 12/14 (2) AWG, 4/2.5 (2) mm ²	Solid Cu: 12/14 (2) AWG, 4/2.5 (2) mm ² Stranded Cu: 12/14 (2) AWG, 4/2.5 (2) mm ²
DIN Rail Mounting, EN 60715	35 mm	35 mm
Chassis Mount Screw Torque	7 Lb-in / 0.8 N•m	7 Lb-in / 0.8 N•m
Flammability Rating	94V-0	94V-0
Weight	57 g (2.01 oz)	57 g (2.01 oz)
Agency Approvals	UL (E70550), CE, CSA (LR97899), RoHS	UL (E70550), CE, CSA (LR97899), RoHS

Dimensions — inches (millimeters)

70-169-1

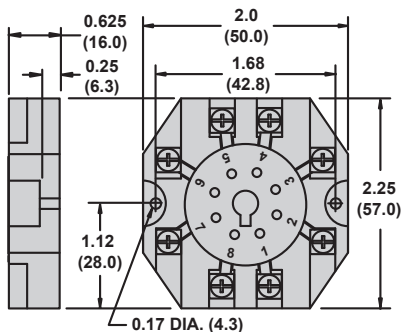

70-170-1

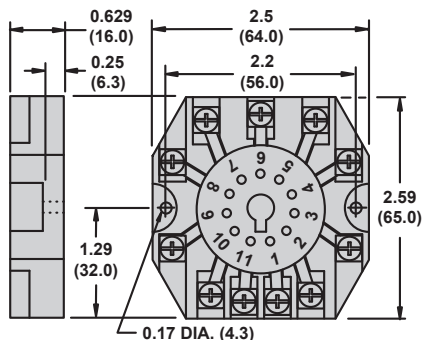

Wiring Diagrams

70-169-1

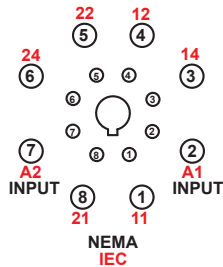

70-170-1

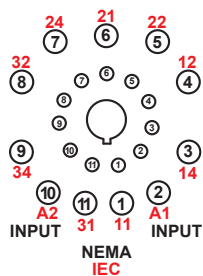

Socket Specifications

Part Number	70-178-1	70-178-2
Contact Configuration	3PDT	3PDT
Number of Terminals	11	11
Mounting Style	Panel / PCB	PCB
Current Rating	15 A	15 A
Nominal Voltage Rating	300 V	300 V
Storage Temperature Range	-40 – +105 °C (-40 – +221 °F)	-40 – +105 °C (-40 – +221 °F)
Operating Temperature Range	-40 – +80 °C (-40 – +176 °F)	-40 – +80 °C (-40 – +176 °F)
Protection Category (Fingersafe)	IP 20	IP 20
Internal Metal Tracks	Copper Alloy, Zinc Plated	Copper Alloy, Zinc Plated
Screw Terminals	Copper Alloy, Zinc Plated	Copper Alloy, Zinc Plated
Screw Style	–	–
Screw Size	–	–
Maximum Screw Torque	–	–
Terminal Connection	PCB	PCB
Terminal Layout	Mix	Mix
Maximum Wire Size	Solid Cu: (Output): 16 AWG, 1.0 mm ² Stranded Cu: (Output): 16 AWG, 1.0 mm ²	Solid Cu: (Output): 16 AWG, 1.0 mm ² Stranded Cu: (Output): 16 AWG, 1.0 mm ²
DIN Rail Mounting, EN 60715	–	–
Chassis Mount Screw Torque	–	–
Flammability Rating	94V-0	94V-0
Weight	12.1 g (0.43 oz)	12.1 g (0.43 oz)
Agency Approvals	UL (E70550), CE, CSA (LR40787), RoHS	UL (E70550), CE, CSA (LR40787), RoHS

Dimensions — inches (millimeters)

70-178-1

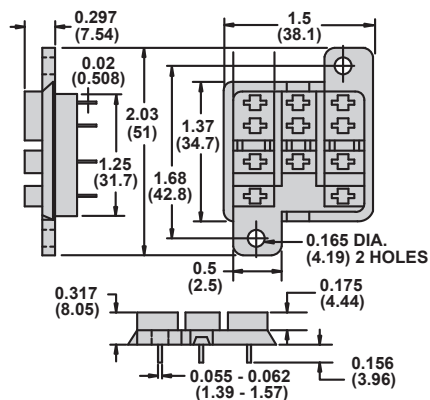

70-178-2

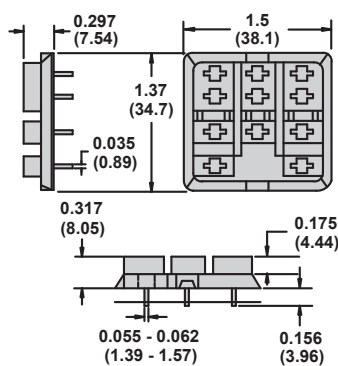

RECOMMENDED CIRCUIT BOARD LAYOUT
FOR 70-178-1 & 70-178-2
BOTTOM VIEW

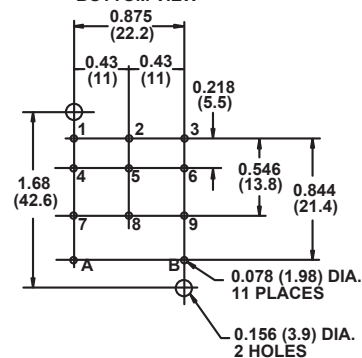

Wiring Diagram

70-178-1 & 70-178-2

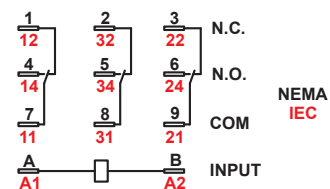

Socket Specifications

Part Number	70-378-1	70-379-1
Contact Configuration	4PDT	4PDT
Number of Terminals	14	14
Mounting Style	Chassis	PCB
Current Rating	5 A	5 A
Nominal Voltage Rating	120 V	120 V
Storage Temperature Range	-40 – +105 °C (-40 – +221 °F)	-40 – +105 °C (-40 – +221 °F)
Operating Temperature Range	-40 – +80 °C (-40 – +176 °F)	-40 – +80 °C (-40 – +176 °F)
Protection Category (Fingersafe)	–	–
Internal Metal Tracks	Copper Alloy, Zinc Plated	Copper Alloy, Zinc Plated
Screw Terminals	Copper Alloy, Zinc Plated	Copper Alloy, Zinc Plated
Screw Style	–	–
Screw Size	–	–
Maximum Screw Torque	–	–
Terminal Connection	Solder	PCB
Terminal Layout	Mix	Mix
Maximum Wire Size	Solid Cu: (Output): 18 AWG, 0.8 mm ² Stranded Cu: (Output): 18 AWG, 0.8 mm ²	–
DIN Rail Mounting, EN 60715	35 mm	–
Chassis Mount Screw Torque	7 Lb-in / 0.8 N·m	–
Flammability Rating	94V-0	94V-0
Weight	6.2 g (0.22 oz)	5.8 g (0.20 oz)
Agency Approvals	UL (E70550), CE, CSA (LR40787), RoHS	UL (E70550), CE, CSA (LR40787), RoHS

Dimensions — inches (millimeters)

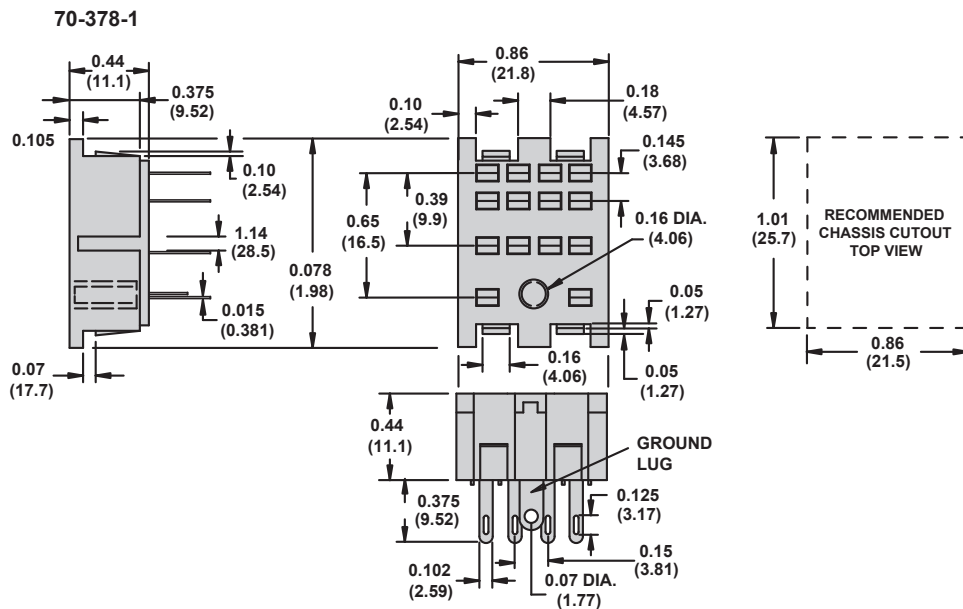

Dimensions — inches (millimeters)

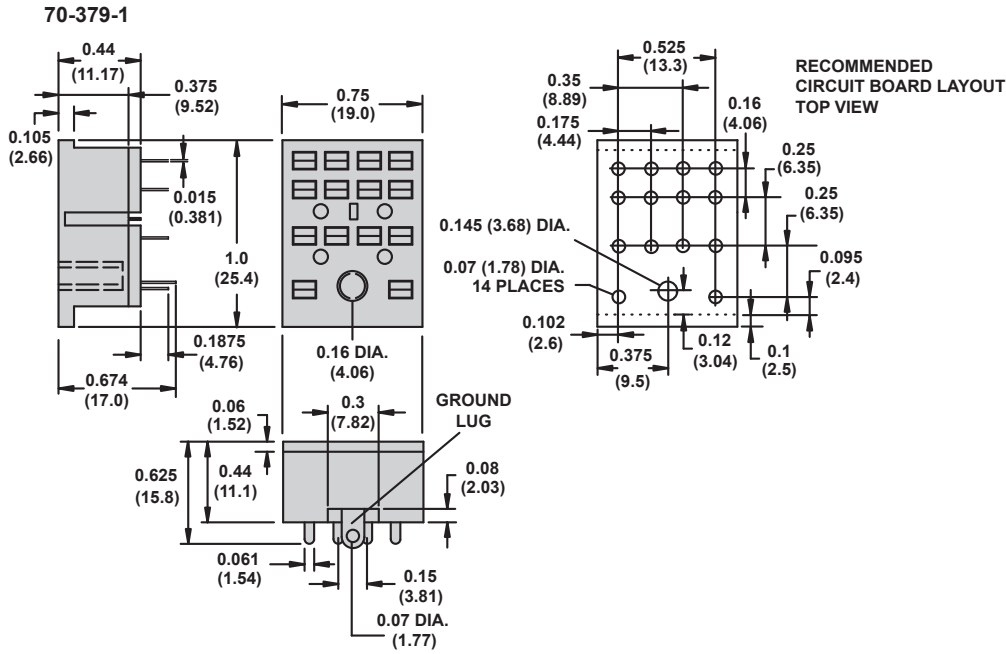

Wiring Diagrams

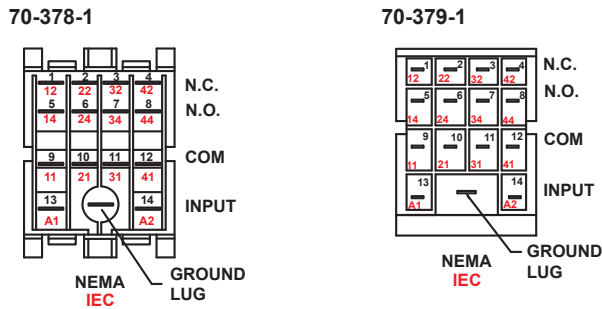

Socket Specifications

Part Number	70-401-1	70-402-1
Contact Configuration	DPDT	DPDT
Number of Terminals	8	8
Mounting Style	Chassis	PCB
Current Rating	10 A	10 A
Nominal Voltage Rating	300 V	300 V
Storage Temperature Range	-40 – +105 °C (-40 – +221 °F)	-40 – +105 °C (-40 – +221 °F)
Operating Temperature Range	-40 – +80 °C (-40 – +176 °F)	-40 – +80 °C (-40 – +176 °F)
Protection Category (Fingersafe)	–	–
Internal Metal Tracks	Copper Alloy, Zinc Plated	Copper Alloy, Zinc Plated
Screw Terminals	Copper Alloy, Zinc Plated	Copper Alloy, Zinc Plated
Screw Style	Combination Head	–
Screw Size	M3.5 mm	–
Maximum Screw Torque	9 Lb-in / 1.0 N•m	–
Terminal Connection	Solder	PCB
Terminal Layout	Mix	Mix
Maximum Wire Size	Solid Cu: (Output): 18 AWG, 0.8 mm ² Stranded Cu: (Output): 18 AWG, 0.8 mm ²	–
DIN Rail Mounting, EN 60715	–	–
Chassis Mount Screw Torque	7 Lb-in / 0.8 N•m	–
Flammability Rating	94V-0	94V-0
Weight	6.2 g (0.22 oz)	6.5 g (0.23 oz)
Agency Approvals	UL (E70550), CE, RoHS	UL (E70550), CE, RoHS

Dimensions — inches (millimeters)

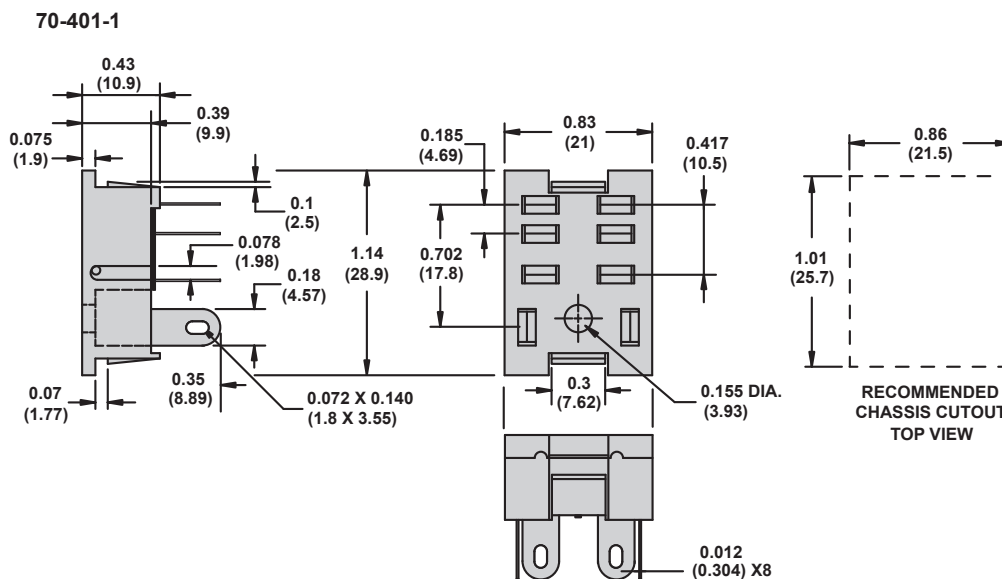

Dimensions — inches (millimeters)

70-402-1

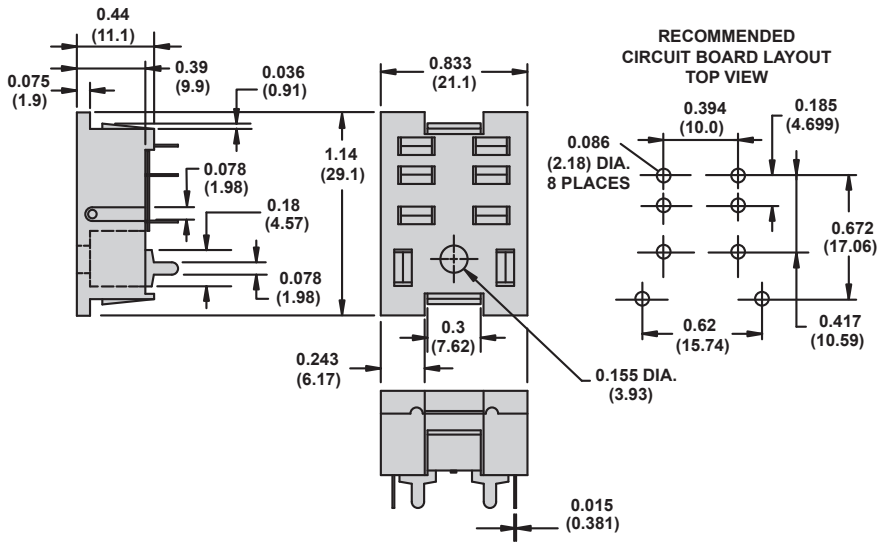

Wiring Diagrams

70-401-1

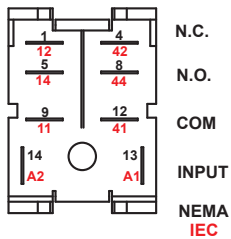

70-402-1

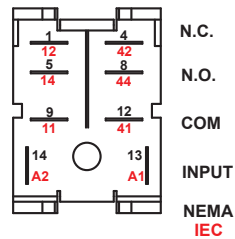

Socket Specifications

Part Number	70-459-1	70-461-1	70-463-1
Contact Configuration	DPDT	4PDT	3PDT
Number of Terminals	8	14	11
Mounting Style	Panel / DIN rail	Panel / DIN rail	Panel / DIN rail
Current Rating	10 A	10 A	15 A
Nominal Voltage Rating	300 V	300 V	300 V
Storage Temperature Range	-40 – +105 °C (-40 – +221 °F)	-40 – +105 °C (-40 – +221 °F)	-40 – +105 °C (-40 – +221 °F)
Operating Temperature Range	-40 – +80 °C (-40 – +176 °F)	-40 – +80 °C (-40 – +176 °F)	-40 – +80 °C (-40 – +176 °F)
Protection Category (Fingersafe)	–	–	–
Internal Metal Tracks	Copper Alloy, Zinc Plated	Copper Alloy, Zinc Plated	Copper Alloy, Zinc Plated
Screw Terminals	Steel, Zinc Plated	Steel, Zinc Plated	Steel, Zinc Plated
Screw Style	Combination Head	Combination Head	Combination Head
Screw Size	M3.5 mm	M3 mm	M3.5 mm
Maximum Screw Torque	9 Lb-in / 1.0 N•m	7 Lb-in / 0.8 N•m	9 Lb-in / 1.0 N•m
Terminal Connection	Screw Clamping	Elevator	Screw Clamping
Terminal Layout	Mix	Separate	Mix
Maximum Wire Size	Solid Cu: 12 / 14 (2) AWG, 4 / 2.5 (2) mm ² Stranded Cu: 12 / 14 (2) AWG, 4 / 2.5 (2) mm ²	Solid Cu: 14 / 16 (2) AWG, 2.5 / 1.5 (2) mm ² Stranded Cu: 14 / 16 (2) AWG, 2.5 / 1.5 (2) mm ²	Solid Cu: 12 / 14 (2) AWG, 4 / 2.5 (2) mm ² Stranded Cu: 12 / 14 (2) AWG, 4 / 2.5 (2) mm ²
DIN Rail Mounting, EN 60715	35 mm	35 mm	35 mm
Chassis Mount Screw Torque	7 Lb-in / 0.8 N•m	7 Lb-in / 0.8 N•m	7 Lb-in / 0.8 N•m
Flammability Rating	94V-0	94V-0	94V-0
Weight	50 g (1.76 oz)	50 g (1.76 oz)	51 g (1.79 oz)
Agency Approvals	UL (E70550), CE, CSA (LR97899), RoHS	UL (E70550), CE, CSA (LR97899), RoHS	UL (E70550), CE, CSA (LR97899), RoHS

Dimensions — inches (millimeters)

70-459-1

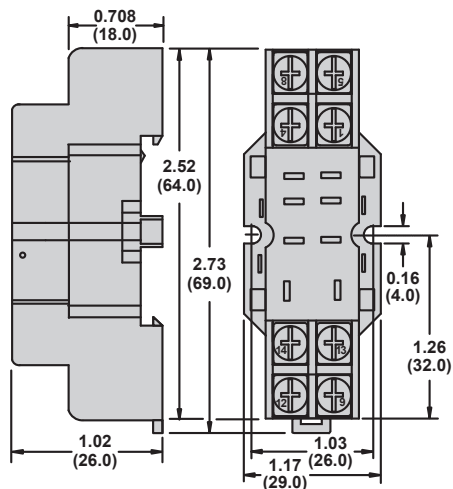

70-461-1

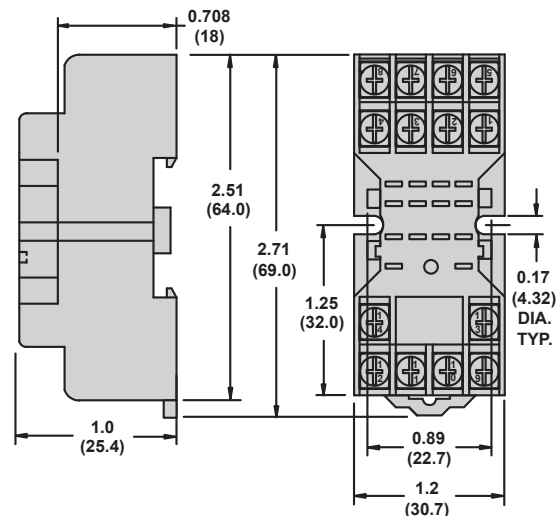

Dimensions — inches (millimeters)

70-463-1

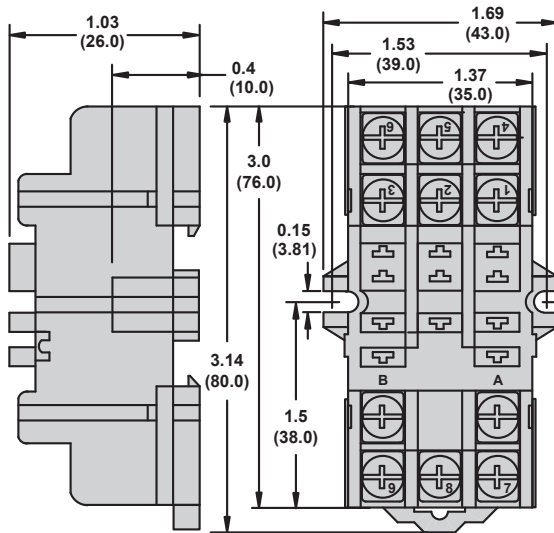

Wiring Diagrams

70-459-1

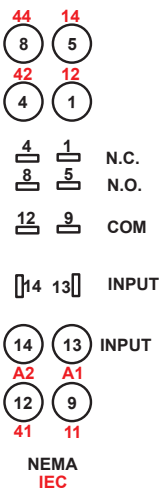

70-461-1

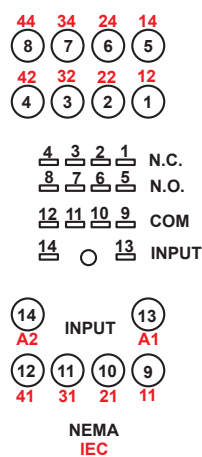

70-463-1

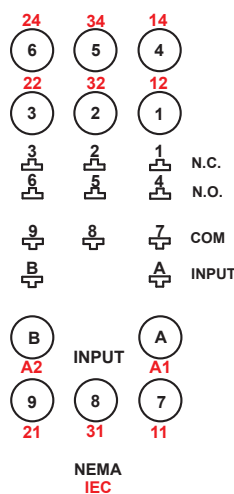

Socket Specifications

Part Number	70-464-1	70-465-1
Contact Configuration	DPDT	3PDT
Number of Terminals	8	11
Mounting Style	Panel / DIN rail	Panel / DIN rail
Current Rating	15 / 10 A	15 / 5 A
Nominal Voltage Rating	300 / 600 V	300 / 600 V
Storage Temperature Range	-40 – +105 °C (-40 – +221 °F)	-40 – +105 °C (-40 – +221 °F)
Operating Temperature Range	-40 – +80 °C (-40 – +176 °F)	-40 – +80 °C (-40 – +176 °F)
Protection Category (Fingersafe)	–	–
Internal Metal Tracks	Copper Alloy, Zinc Plated	Copper Alloy, Zinc Plated
Screw Terminals	Steel, Zinc Plated	Steel, Zinc Plated
Screw Style	Combination Head	Combination Head
Screw Size	M3.5 mm	M3.5 mm
Maximum Screw Torque	9 Lb-in / 1.0 N•m	9 Lb-in / 1.0 N•m
Terminal Connection	Screw Clamping	Screw Clamping
Terminal Layout	Mix	Mix
Maximum Wire Size	Solid Cu: 12/14 (2) AWG, 4/2.5 (2) mm ² Stranded Cu: 12/14 (2) AWG, 4/2.5 (2) mm ²	Solid Cu: 12/14 (2) AWG, 4/2.5 (2) mm ² Stranded Cu: 12/14 (2) AWG, 4/2.5 (2) mm ²
DIN Rail Mounting, EN 60715	35 mm	35 mm
Chassis Mount Screw Torque	7 Lb-in / 0.8 N•m	7 Lb-in / 0.8 N•m
Flammability Rating	94V-0	94V-0
Weight	40 g (1.41 oz)	57 g (2.01 oz)
Agency Approvals	UL (E70550), CE, CSA (LR97899), RoHS	UL (E70550), CE, CSA (LR97899), RoHS

Dimensions — inches (millimeters)

70-464-1

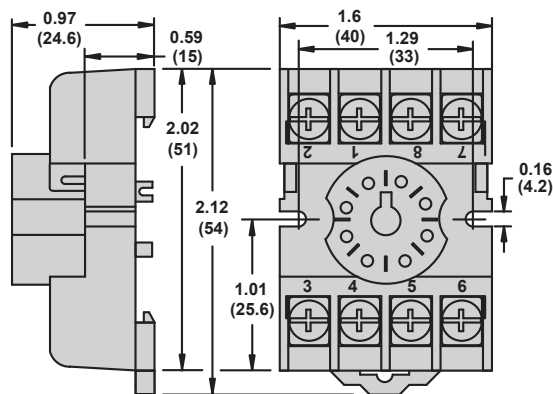

70-465-1

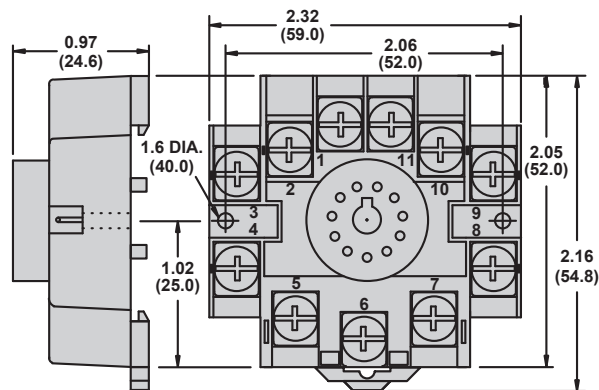

Wiring Diagrams

70-464-1

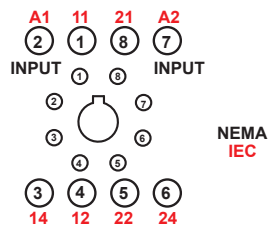

70-465-1

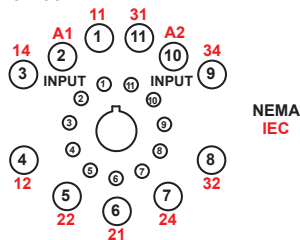

Socket Specifications

Part Number	70-750DL8-1	70-750DL11-1
Contact Configuration	DPDT	3PDT
Number of Terminals	8	11
Mounting Style	Panel / DIN rail	Panel / DIN rail
Current Rating	16 A	16 A
Nominal Voltage Rating	300 V	600 V
Storage Temperature Range	-40 – +105 °C (-40 – +221 °F)	-40 – +105 °C (-40 – +221 °F)
Operating Temperature Range	-40 – +80 °C (-40 – +176 °F)	-40 – +80 °C (-40 – +176 °F)
Protection Category (Fingersafe)	IP 20	IP 20
Internal Metal Tracks	Copper Alloy, Zinc Plated	Copper Alloy, Zinc Plated
Screw Terminals	Steel, Zinc Plated	Steel, Zinc Plated
Screw Style	Combination Head	Combination Head
Screw Size	M3.5 mm	M3.5 mm
Maximum Screw Torque	9 Lb-in / 1.0 N•m	9 Lb-in / 1.0 N•m
Terminal Connection	Screw Clamping	Screw Clamping
Terminal Layout	Mix	Mix
Maximum Wire Size	Solid Cu: 12/14 (2) AWG, 4/2.5 (2) mm ² Stranded Cu: 12/14 (2) AWG, 4/2.5 (2) mm ²	Solid Cu: 12/14 (2) AWG, 4/2.5 (2) mm ² Stranded Cu: 12/14 (2) AWG, 4/2.5 (2) mm ²
DIN Rail Mounting, EN 60715	35 mm	35 mm
Chassis Mount Screw Torque	7 Lb-in / 0.8 N•m	7 Lb-in / 0.8 N•m
Flammability Rating	94V-0	94V-0
Weight	60 g (2.12 oz)	78 g (2.75 oz)
Agency Approvals	UL (E70550), CE, CSA (LR40787), RoHS	UL (E70550), CE, CSA (LR40787), RoHS

Dimensions — inches (millimeters)

70-750DL11-1

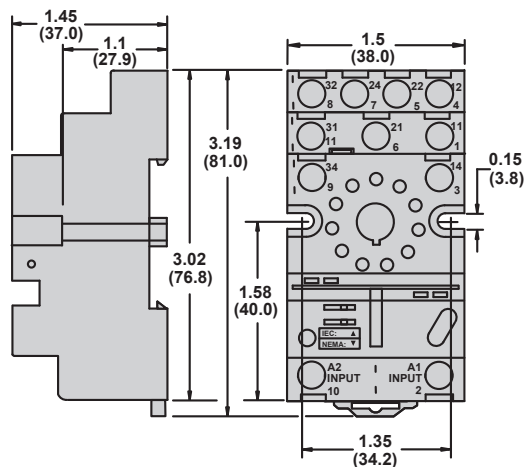

70-750DL8-1

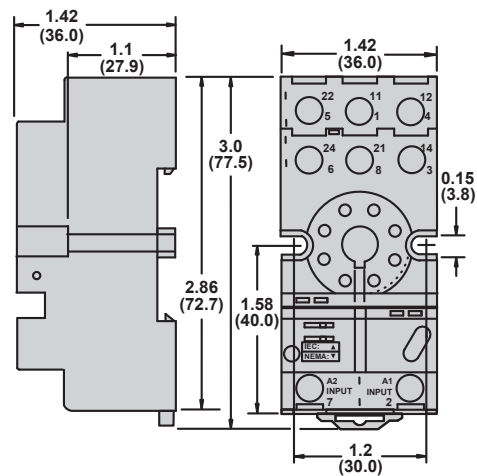

Wiring Diagrams

70-750DL11-1

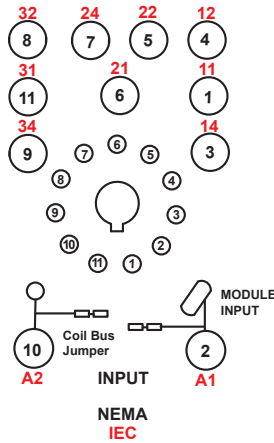

70-750DL8-1

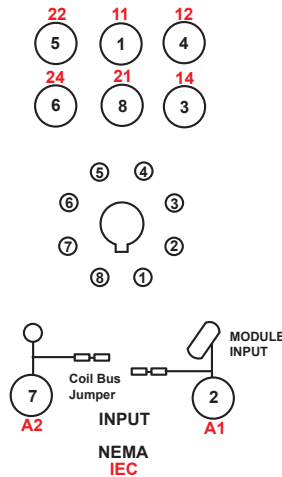

Socket Specifications

Part Number	70-750E8-1	70-750E11-1
Contact Configuration	DPDT	3PDT
Number of Terminals	8	11
Mounting Style	Panel / DIN rail	Panel / DIN rail
Current Rating	12 A	12 A
Nominal Voltage Rating	300 V	300 V
Storage Temperature Range	-40 – +105 °C (-40 – +221 °F)	-40 – +105 °C (-40 – +221 °F)
Operating Temperature Range	-40 – +80 °C (-40 – +176 °F)	-40 – +80 °C (-40 – +176 °F)
Protection Category (Fingersafe)	IP 20	IP 20
Internal Metal Tracks	Copper Alloy, Zinc Plated	Copper Alloy, Zinc Plated
Screw Terminals	Steel, Zinc Plated	Steel, Zinc Plated
Screw Style	Combination Head	Combination Head
Screw Size	M3.5 mm	M3.5 mm
Maximum Screw Torque	9 Lb-in / 1.0 N•m	9 Lb-in / 1.0 N•m
Terminal Connection	Elevator	Elevator
Terminal Layout	Separate	Separate
Maximum Wire Size	Solid Cu: 12/14 (2) AWG, 4/2.5 (2) mm ² Stranded Cu: 12/14 (2) AWG, 4/2.5 (2) mm ²	Solid Cu: 12/14 (2) AWG, 4/2.5 (2) mm ² Stranded Cu: 12/14 (2) AWG, 4/2.5 (2) mm ²
DIN Rail Mounting, EN 60715	35 mm	35 mm
Chassis Mount Screw Torque	7 Lb-in / 0.8 N•m	7 Lb-in / 0.8 N•m
Flammability Rating	94V-0	94V-0
Weight	85 g (3.0 oz)	85 g (3.0 oz)
Agency Approvals	UL (E70550), CE, CSA (LR40787), RoHS	UL (E70550), CE, CSA (LR40787), RoHS

Dimensions — inches (millimeters)

70-750E11-1

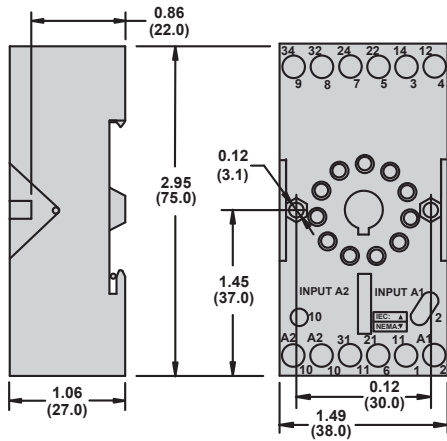

70-750E8-1

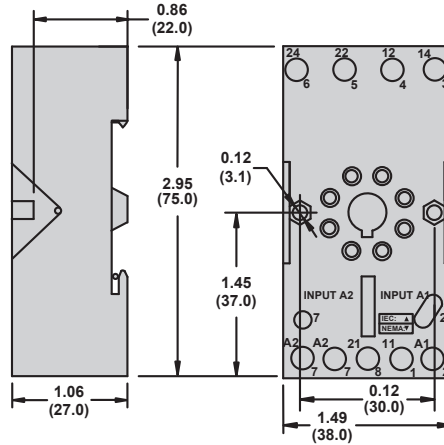

Wiring Diagrams

70-750E11-1

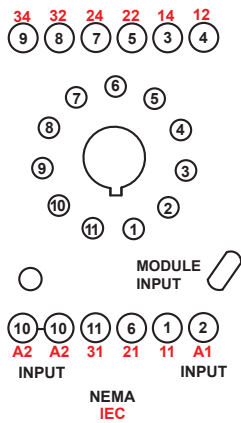

70-750E8-1

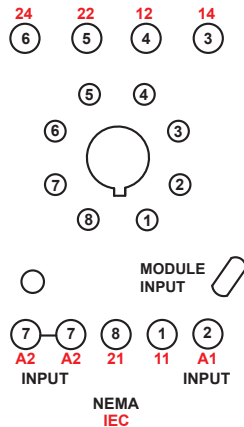

Socket Specifications

Part Number	70-750EL8-1	70-750EL11-1
Contact Configuration	DPDT	3PDT
Number of Terminals	8	11
Mounting Style	Panel / DIN rail	Panel / DIN rail
Current Rating	16 A	16 A
Nominal Voltage Rating	300 V	300 V
Storage Temperature Range	-40 – +105 °C (-40 – +221 °F)	-40 – +105 °C (-40 – +221 °F)
Operating Temperature Range	-40 – +80 °C (-40 – +176 °F)	-40 – +80 °C (-40 – +176 °F)
Protection Category (Fingersafe)	IP 20	IP20
Internal Metal Tracks	Copper Alloy, Zinc Plated	Copper Alloy, Zinc Plated
Screw Terminals	Steel, Zinc Plated	Steel, Zinc Plated
Screw Style	Combination Head	Combination Head
Screw Size	M3.5 mm	M3.5 mm
Maximum Screw Torque	9 Lb-in / 1.0 N•m	9 Lb-in / 1.0 N•m
Terminal Connection	Elevator	Elevator
Terminal Layout	Separate	Separate
Maximum Wire Size	Solid Cu: 12/14 (2) AWG, 4/2.5 (2) mm ² Stranded Cu: 12/14 (2) AWG, 4/2.5 (2) mm ²	Solid Cu: 12 / 14 (2) AWG, 4 / 2.5 (2) mm ² Stranded Cu: 12 / 14 (2) AWG, 4 / 2.5 (2) mm ²
DIN Rail Mounting, EN 60715	35 mm	35 mm
Chassis Mount Screw Torque	7 Lb-in / 0.8 N•m	7 Lb-in / 0.8 N•m
Flammability Rating	94V-0	94V-0
Weight	79 g (2.79 oz)	79 g (2.79 oz)
Agency Approvals	UL (E70550), CE, CSA (LR40787), RoHS	UL (E70550), CE, CSA (LR40787), RoHS

Dimensions — inches (millimeters)

70-750EL11-1

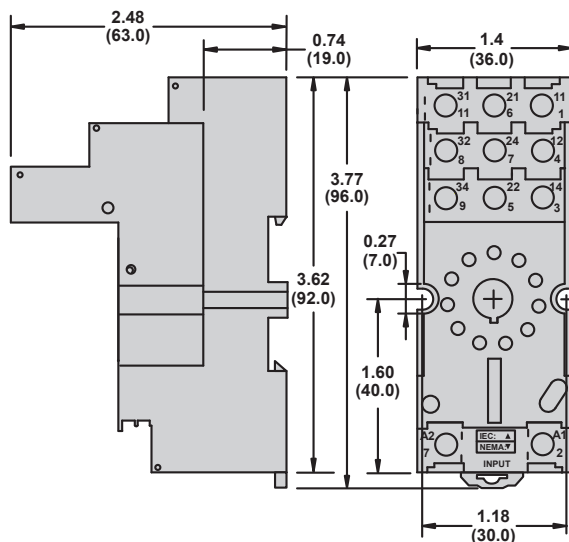

70-750EL8-1

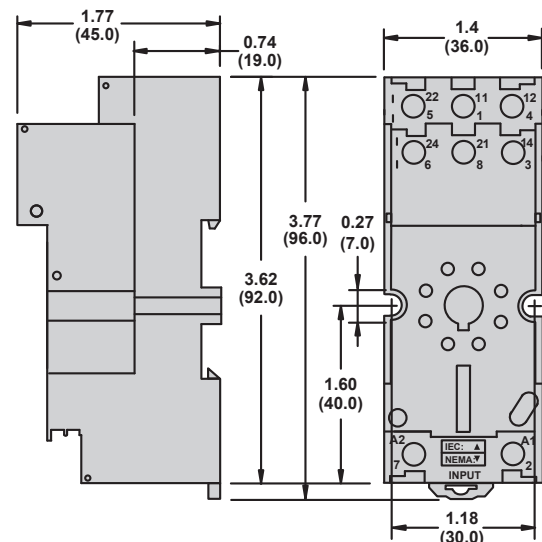

Wiring Diagrams

70-750EL11-1

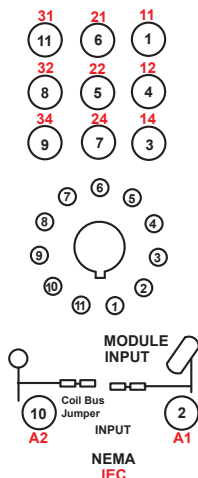

70-750EL8-1

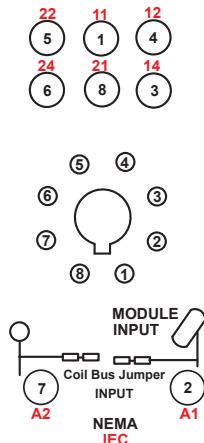

Socket Specifications

Part Number	70-781D5-1A	70-781T-1
Contact Configuration	SPDT	SPDT
Number of Terminals	5	5
Mounting Style	Panel / DIN rail	PCB
Current Rating	20 A	10 A
Nominal Voltage Rating	300 V	300 V
Storage Temperature Range	-40 – +105 °C (-40 – +221 °F)	-40 – +105 °C (-40 – +221 °F)
Operating Temperature Range	-40 – +80 °C (-40 – +176 °F)	-40 – +80 °C (-40 – +176 °F)
Protection Category (Fingersafe)	IP 20	–
Internal Metal Tracks	Copper Alloy, Zinc Plated	Copper Alloy, Zinc Plated
Screw Terminals	Steel, Zinc Plated	Copper Alloy, Zinc Plated
Screw Style	Combination Head	–
Screw Size	M3 mm / M3.5 mm	–
Maximum Screw Torque	M3 : 9 Lb-in / 0.8 N•m; M3.5 : 9 Lb-in / 1.0 N•m	–
Terminal Connection	Screw Clamping	PCB
Terminal Layout	Mix	Mix
Maximum Wire Size	Solid Cu: 12 / 14 (2) AWG, 4 / 2.5 (2) mm ² Stranded Cu: 12 / 14 (2) AWG, 4 / 2.5 (2) mm ²	–
DIN Rail Mounting, EN 60715	35 mm	–
Chassis Mount Screw Torque	7 Lb-in / 0.8 N•m	–
Flammability Rating	94V-0	94V-0
Weight	35 g (1.23 oz)	18 g (0.63 oz)
Agency Approvals	UL (E70550), CE, CSA (168986), RoHS	UL (E70550), CE, RoHS

Dimensions — inches (millimeters)

70-781D5-1A

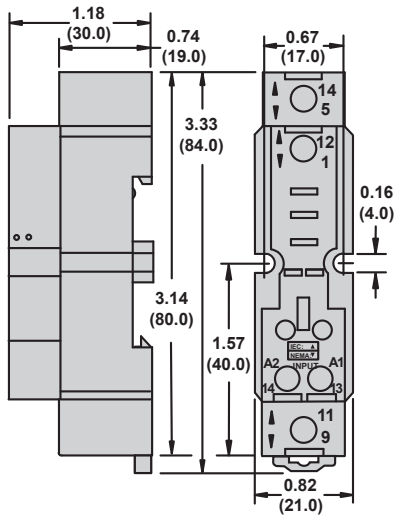

70-781T-1

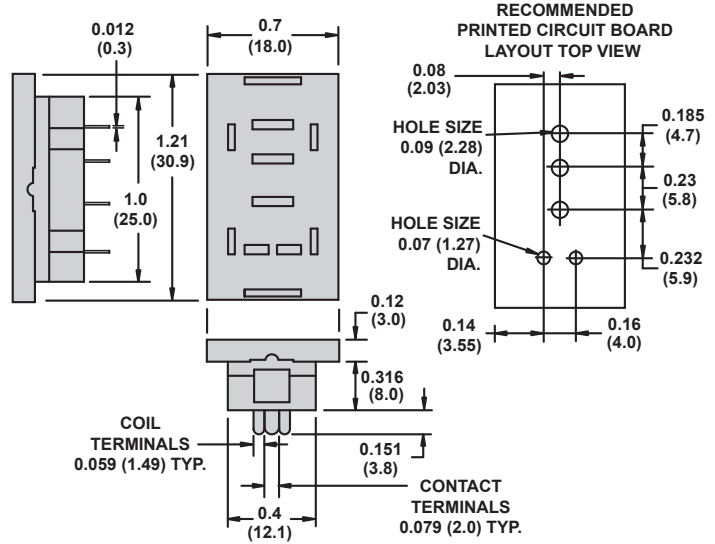

Wiring Diagrams

70-781D5-1A

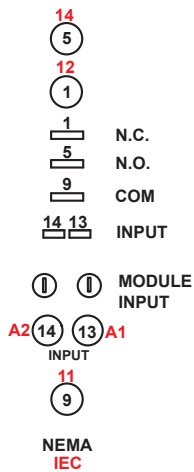

70-781T-1

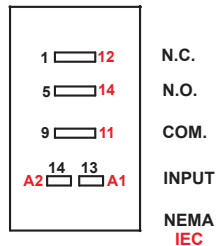

Socket Specifications

Part Number	70-782D8-1A	70-782D14-1
Contact Configuration	DPDT	4PDT
Number of Terminals	8	14
Mounting Style	Panel / DIN rail	Panel / DIN rail
Current Rating	16 A	10 A
Nominal Voltage Rating	300 V	300 V
Storage Temperature Range	-40 – +105 °C (-40 – +221 °F)	-40 – +105 °C (-40 – +221 °F)
Operating Temperature Range	-40 – +80 °C (-40 – +176 °F)	-40 – +80 °C (-40 – +176 °F)
Protection Category (Fingersafe)	IP 20	IP 20
Internal Metal Tracks	Copper Alloy, Zinc Plated	Copper Alloy, Zinc Plated
Screw Terminals	Steel, Zinc Plated	Steel, Zinc Plated
Screw Style	Combination Head	Combination Head
Screw Size	M3.5 mm	M3 mm
Maximum Screw Torque	9 Lb-in / 1.0 N•m	7 Lb-in / 0.8 N•m
Terminal Connection	Screw Clamping	Screw Clamping
Terminal Layout	Mix	Mix
Maximum Wire Size	Solid Cu: 12 / 14 (2) AWG, 4 / 2.5 (2) mm ² Stranded Cu: 12 / 14 (2) AWG, 4 / 2.5 (2) mm ²	Solid Cu: 12 / 14 (2) AWG, 4 / 2.5 (2) mm ² Stranded Cu: 12 / 14 (2) AWG, 4 / 2.5 (2) mm ²
DIN Rail Mounting, EN 60715	35 mm	35 mm
Chassis Mount Screw Torque	7 Lb-in / 0.8 N•m	7 Lb-in / 0.8 N•m
Flammability Rating	94V-0	94V-0
Weight	55 g (1.94 oz)	62 g (2.19 oz)
Agency Approvals	UL (E70550), CE, CSA (LR40787), RoHS	UL (E70550), CE, CSA (LR40787), RoHS

Dimensions — inches (millimeters)

70-782D8-1A

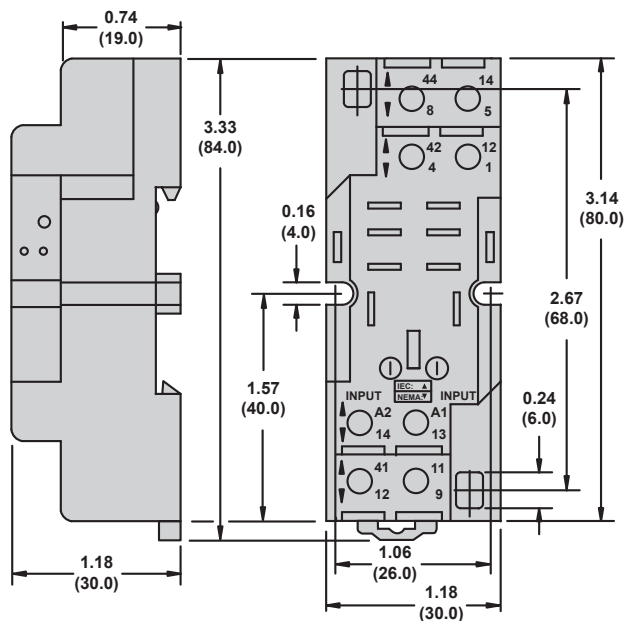

70-782D14-1

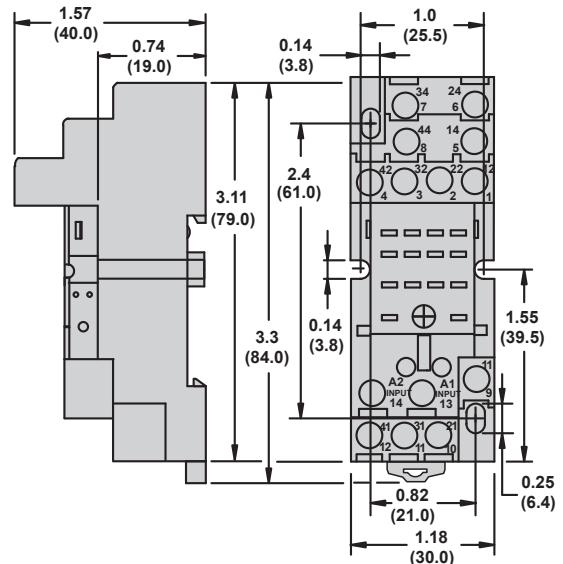

Wiring Diagrams

70-782D8-1A

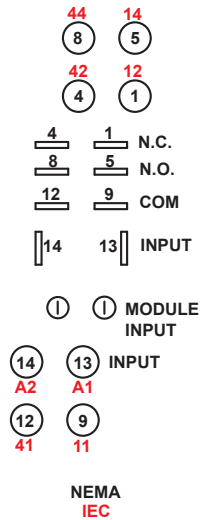

70-782D14-1

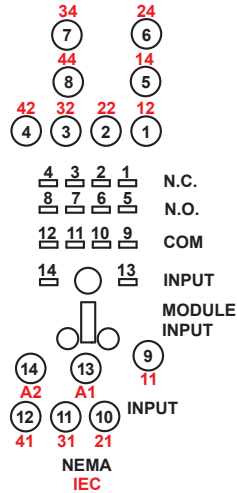

Socket Specifications

Part Number	70-782E14-1	70-782EL8-1
Contact Configuration	4PDT	DPDT
Number of Terminals	14	8
Mounting Style	Panel / DIN rail	Panel / DIN rail
Current Rating	10 A	12 A
Nominal Voltage Rating	300 V	300 V
Storage Temperature Range	-40 – +105 °C (-40 – +221 °F)	-40 – +105 °C (-40 – +221 °F)
Operating Temperature Range	-40 – +80 °C (-40 – +176 °F)	-40 – +80 °C (-40 – +176 °F)
Protection Category (Fingersafe)	IP 20	IP 20
Internal Metal Tracks	Copper Alloy, Zinc Plated	Copper Alloy, Zinc Plated
Screw Terminals	Steel, Zinc Plated	Steel, Zinc Plated
Screw Style	Combination Head	Combination Head
Screw Size	M3 mm	M3.5 mm
Maximum Screw Torque	7 Lb-in / 0.8 N•m	9 Lb-in / 1.0 N•m
Terminal Connection	Elevator	Elevator
Terminal Layout	Separate	Separate
Maximum Wire Size	Solid Cu: 14 / 16 (2) AWG, 2.5 / 1.5 (2) mm ² Stranded Cu: 14 / 16 (2) AWG, 2.5 / 1.5 (2) mm ²	Solid Cu: 12 / 14 (2) AWG, 4 / 2.5 (2) mm ² Stranded Cu: 12 / 14 (2) AWG, 4 / 2.5 (2) mm ²
DIN Rail Mounting, EN 60715	35 mm	35 mm
Chassis Mount Screw Torque	7 Lb-in / 0.8 N•m	7 Lb-in / 0.8 N•m
Flammability Rating	94V-0	94V-0
Weight	56 g (1.98 oz)	46 g (1.62 oz)
Agency Approvals	UL (E70550) CE, CSA (LR40787), RoHS	UL (E70550), CE, CSA (LR40787), RoHS

Socket Specifications

Part Number	70-782EL14-1
Contact Configuration	4PDT
Number of Terminals	14
Mounting Style	Panel / DIN rail
Current Rating	10 A
Nominal Voltage Rating	300 V
Storage Temperature Range	-40 – +105 °C (-40 – +221 °F)
Operating Temperature Range	-40 – +80 °C (-40 – +176 °F)
Protection Category (Fingersafe)	IP 20
Internal Metal Tracks	Copper Alloy, Zinc Plated
Screw Terminals	Steel, Zinc Plated
Screw Style	Combination Head
Screw Size	M3 mm
Maximum Screw Torque	7 Lb-in / 0.8 N·m
Terminal Connection	Elevator
Terminal Layout	Separate
Maximum Wire Size	Solid Cu: 14 / 16 (2) AWG, 2.5 / 1.5 (2) mm ² Stranded Cu: 14 / 16 (2) AWG, 2.5 / 1.5 (2) mm ²
DIN Rail Mounting, EN 60715	35 mm
Chassis Mount Screw Torque	7 Lb-in / 0.8 N·m
Flammability Rating	94V-0
Weight	62 g (2.19 oz)
Agency Approvals	UL (E70550), CE, CSA (LR40787), RoHS

Dimensions — inches (millimeters)

70-782EL14-1

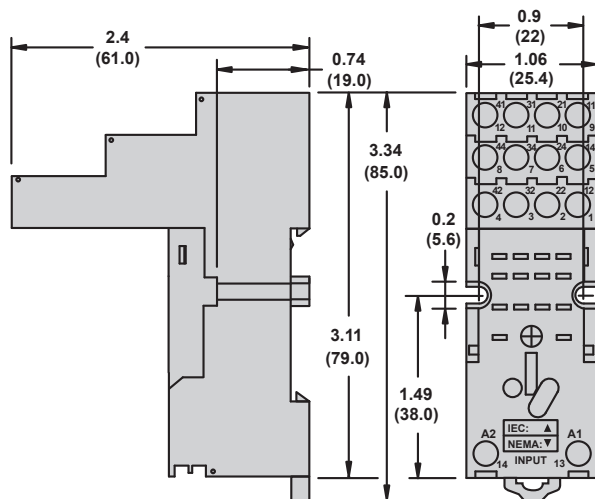

Wiring Diagrams

70-782EL14-1

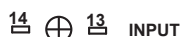
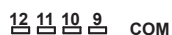
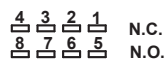

NEMA
IEC

Socket Specifications

Part Number	70-783D11-1A	70-784D14-1
Contact Configuration	3PDT	4PDT
Number of Terminals	11	14
Mounting Style	Panel / DIN rail	Panel / DIN rail
Current Rating	16 A	16 A
Nominal Voltage Rating	300 V	300 V
Storage Temperature Range	-40 – +105 °C (-40 – +221 °F)	-40 – +105 °C (-40 – +221 °F)
Operating Temperature Range	-40 – +80 °C (-40 – +176 °F)	-40 – +80 °C (-40 – +176 °F)
Protection Category (Fingersafe)	IP 20	IP 20
Internal Metal Tracks	Copper Alloy, Zinc Plated	Copper Alloy, Zinc Plated
Screw Terminals	Steel, Zinc Plated	Steel, Zinc Plated
Screw Style	Combination Head	Combination Head
Screw Size	M3.5 mm	M3.5 mm
Maximum Screw Torque	9 Lb-in / 1.0 N•m	9 Lb-in / 1.0 N•m
Terminal Connection	Screw Clamping	Screw Clamping
Terminal Layout	Mix	Mix
Maximum Wire Size	Solid Cu: 12 / 14 (2) AWG, 4 / 2.5 (2) mm ² Stranded Cu: 12 / 14 (2) AWG, 4 / 2.5 (2) mm ²	Solid Cu: 12 / 14 (2) AWG, 4 / 2.5 (2) mm ² Stranded Cu: 12 / 14 (2) AWG, 4 / 2.5 (2) mm ²
DIN Rail Mounting, EN 60715	35 mm	35 mm
Chassis Mount Screw Torque	7 Lb-in / 0.8 N•m	7 Lb-in / 0.8 N•m
Flammability Rating	94V-0	94V-0
Weight	55 g (1.94oz)	62 g (2.19 oz)
Agency Approvals	CE, RoHS, UL,(E70550) CSA (LR40787)	CE, RoHS, UL,(E70550) CSA (LR40787)

Dimensions — inches (millimeters)

70-783D11-1A

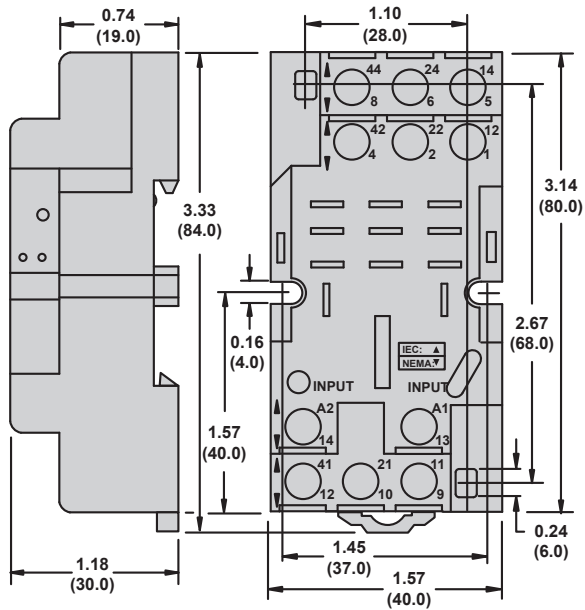

70-784D14-1

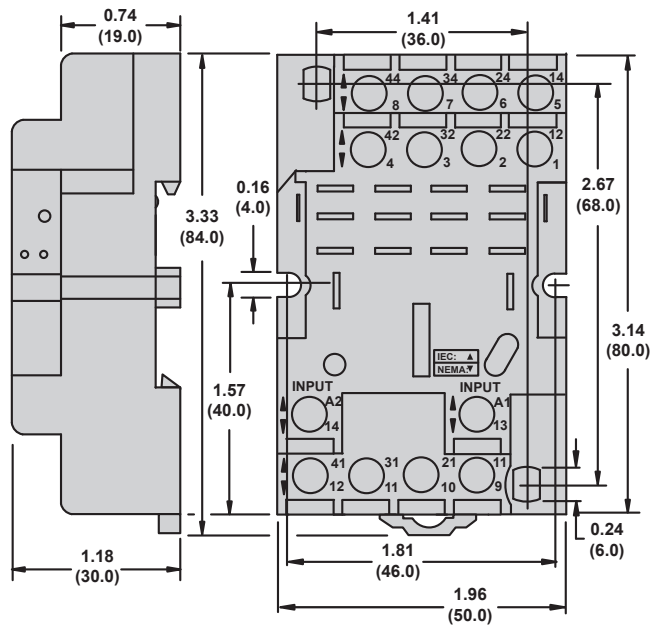

Wiring Diagrams

70-783D11-1A

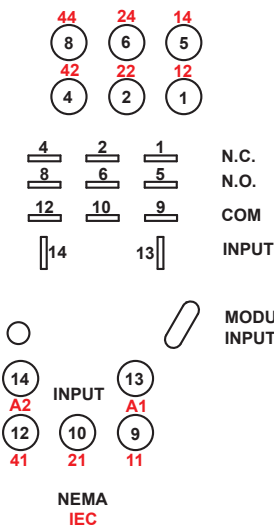

70-784D14-1

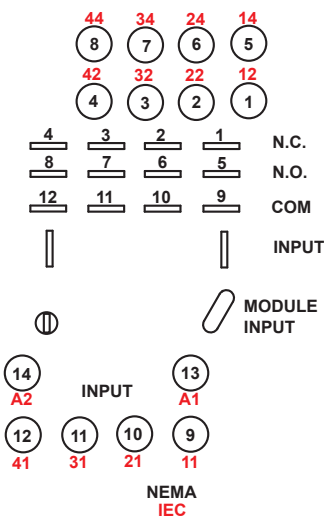

Socket Specifications

Part Number	70-788EL11-1
Contact Configuration	3PDT
Number of Terminals	11
Mounting Style	DIN rail
Current Rating	25 A
Nominal Voltage Rating	300 V
Storage Temperature Range	-40 – +105 °C (-40 – +221 °F)
Operating Temperature Range	-40 – +80 °C (-40 – +176 °F)
Protection Category (Fingersafe)	IP 20
Internal Metal Tracks	Copper Alloy, Zinc Plated
Screw Terminals	Steel, Zinc Plated
Screw Style	Combination Head
Screw Size	M3.5 mm
Maximum Screw Torque	9 Lb-in / 1.0 N•m
Terminal Connection	Elevator
Terminal Layout	Separate
Maximum Wire Size	Solid Cu: 10 / 14 (2) AWG, 6 / 2.5 (2) mm ² Stranded Cu: 10 / 14 (2) AWG, 6 / 2.5 (2) mm ²
DIN Rail Mounting, EN 60715	35 mm
Chassis Mount Screw Torque	7 Lb-in / 0.8 N•m
Flammability Rating	94V-0
Weight	96 g (3.39 oz)
Agency Approvals	UL (E70550), CE, CSA (LR40787), RoHS

Dimensions — inches (millimeters)

70-788EL11-1

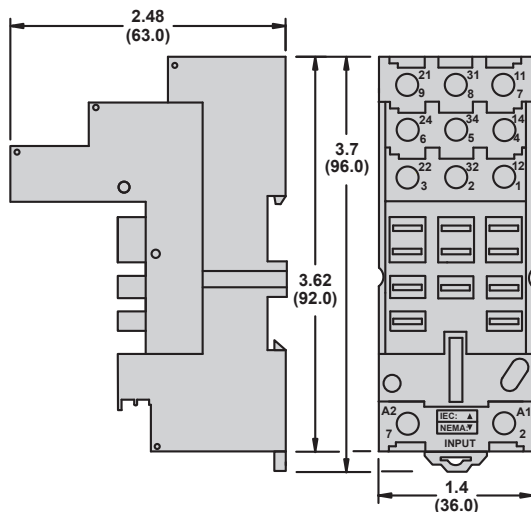

Wiring Diagram

70-788EL11-1

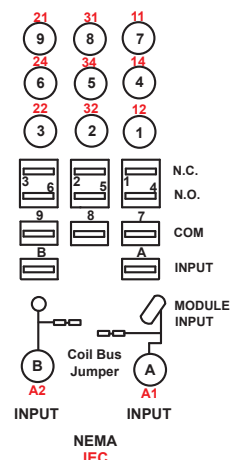

Mounting Adapter Specifications

Part Number	16-781C	16-782C	16-783C	16-784C	16-781C1	16-782C2	16-783C1	16-784C1
Mounting Style	DIN rail / panel				Panel			
Mating Relays	781 Series	782 Series	783 Series	784 Series	781 Series	782 Series	783 Series	784 Series
Agency Approvals	RoHS							

Key Features

- No need to purchase a socket
- DIN or Panel mounting
- Plastic construction
- Light weight
- Low cost
- Low profile
- Write-On label
- Narrow mounting
- Easy termination



Mounting Adapter Dimensions — inches (millimeters)

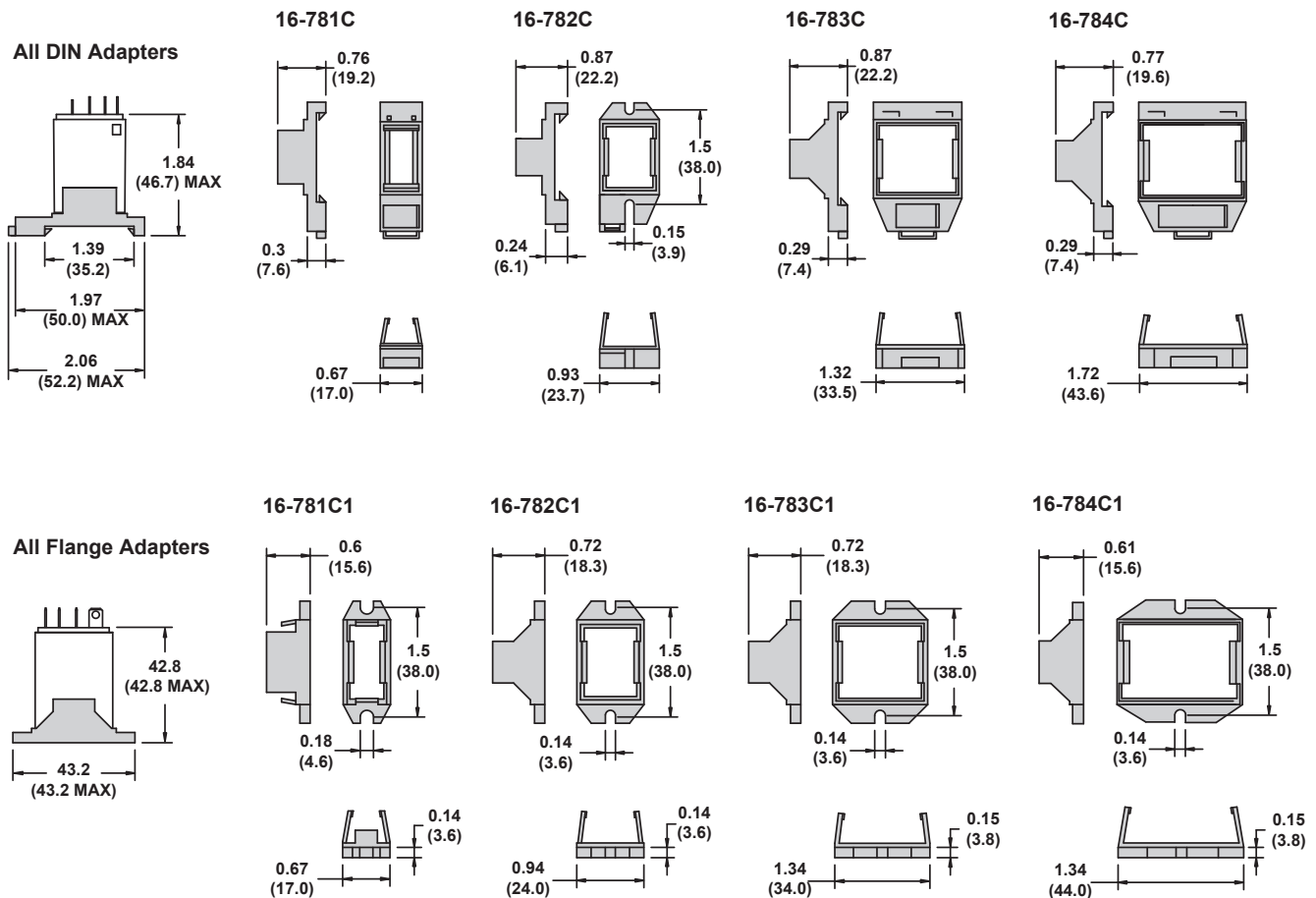

■ Overview	67
■ Hold-Down Clips	68
■ Insulated Coil Bus Jumper System	71
■ DIN Rail and DIN Clip	71
■ ID Tags	71
■ Panel Mount Adapter	72
■ Socket Modules	72

Product Overview

Hold-Down Clips

Safely secure relay to socket.
Available in plastic or stainless steel.

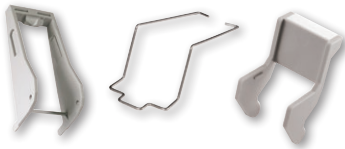

Socket Modules

Allow for optional circuit protection (Diode, MOV or RC) or status indicator LED. Modules plug into mating sockets.



DIN Rail and Locking End Clip

Enables quick installation and removal of sockets.

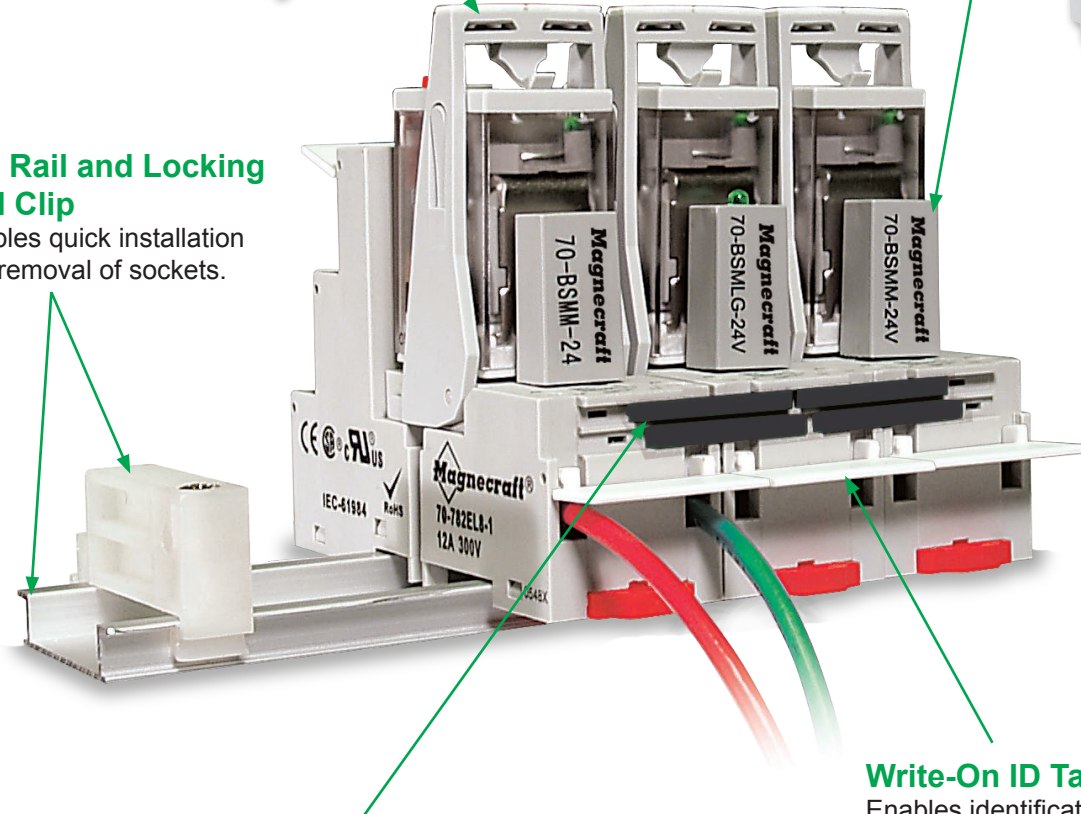
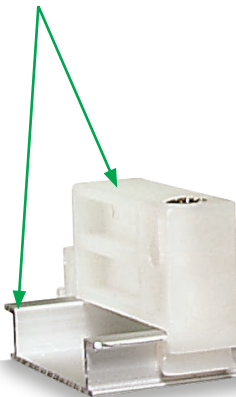

Insulated Coil Bus Jumper System

Allows for connection to adjacent sockets without any additional wiring and no tools necessary.



Write-On ID Tags

Enables identification of relays in multi-relay circuits. Tag snaps onto mating socket.



Magnecraft General Purpose Relays

Socket Accessories

Hold-Down Clips

The table below is designed to allow for easy selection of Magnecraft hold-down clips based on socket and relay compatibility.

Key Features

- Stainless steel spring clips are designed to secure the relay to the socket in harsh environments
- Plastic ejector clips are designed to secure and eject relays from tight, multi-socket applications
- Plastic ID clips are designed to allow for easy identification of circuits in multi-relay applications; an ID tag is supplied with each clip

Socket Part Number	Relays	Clip Part Number	Clip Type
70-124-2	788XBX / 788XCX	16-1351	Spring Clip
70-178-1	788XBX / 788XCX	16-1351	Spring Clip
70-178-2	788XBX / 788XCX	16-1351	Spring Clip
70-378-1	792XDX Control, 782XDXH	16-1342	Spring Clip
70-379-1	792XDX Control, 782XDXH	16-1342	Spring Clip
70-401-1	782XBX Power	16-1342	Spring Clip
70-402-1	782XBX Power	16-1342	Spring Clip
70-459-1	782XBX Power	16-1342	Spring Clip
70-461-1	792XDX Control, 782XDXH	16-1342	Spring Clip
70-463-1	788XBX / 788XCX	16-1351	Spring Clip
70-464-1	750XBX, 750XBXH	16-1351	Spring Clip
70-465-1	750XCX, 750XCXH	16-1351	Spring Clip
70-750DL8-1	750XBX	16-1332	Spring Clip
	750XBXH	16-1351	Spring Clip
70-750DL11-1	750XCX	16-1332	Spring Clip
	750XCXH	16-1351	Spring Clip
70-750E8-1	750XBX	16-1344	Spring Clip
	750XBX, 750XBXH	16-1351	Spring Clip
70-750E11-1	750XCX, 750XCXH	16-1351	Spring Clip
70-750EL8-1	750XBX	16-1351	Spring Clip
70-750EL11-1	750XCX	16-1351	Spring Clip
70-781D5-1A		16-781IDC	ID Clip
		16-781SC	Spring Clip
70-781T-1	781XAX	16-781SC	Spring Clip
70-782D8-1A	782XBX Power	16-1342	Spring Clip
		16-782IDC	ID Clip
		16-782PC-1	Ejector Clip
70-782D14-1	792XBX / 792XDX Control	16-782SC	Spring Clip
	792XBX / 792XDX Control (Full-feature cover only)	16-782PC-1	Ejector Clip
	782XDXH	16-1342	Spring Clip
70-782E14-1	792XBX / 792XDX Control	16-782SC	Spring Clip
	792XBX / 792XDX Control (Full-feature cover only)	16-782PC-1	Ejector Clip
	782XDXH	16-1342	Spring Clip
70-782EL8-1	792XBX Control	16-782SC	Spring Clip
	792XBX Control (Full-feature cover only)	16-782PC-1	Ejector Clip
70-782EL14-1	792XBX / 792XDX Control	16-782SC	Spring Clip
	792XBX / 792XDX Control (Full-feature cover only)	16-782PC-1	Ejector Clip
	782XDXH	16-1342	Spring Clip
70-783D11-1A	783XCX	16-783IDC	ID Clip
		16-783SC	Spring Clip
70-784D14-1	784XDX	16-784IDC	ID Clip
		16-784SC	Spring Clip
70-788EL11-1	788XBX / 788XCX	16-1351	Spring Clip

Hold-Down Clip Dimensions — inches (millimeters)

16-781IDC

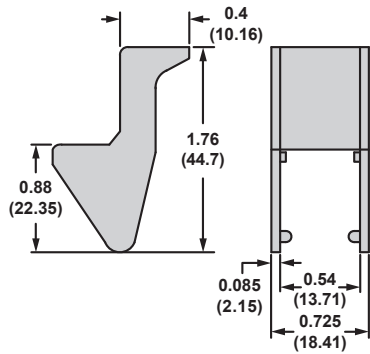

16-781SC

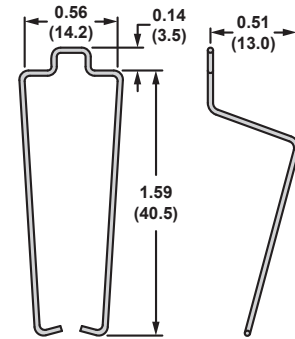

16-782IDC

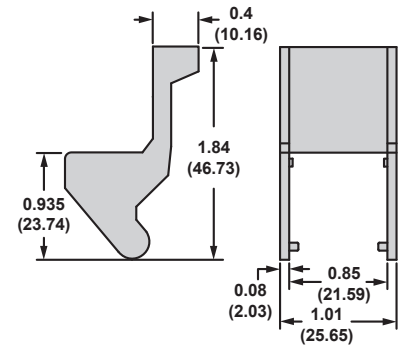

16-782PC

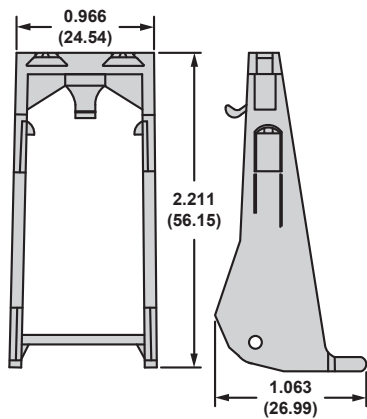

16-782SC

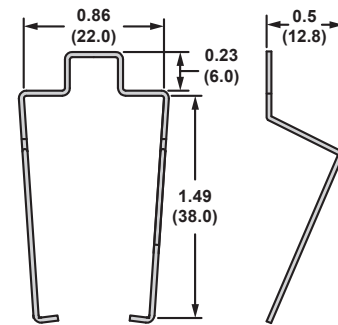

16-783IDC

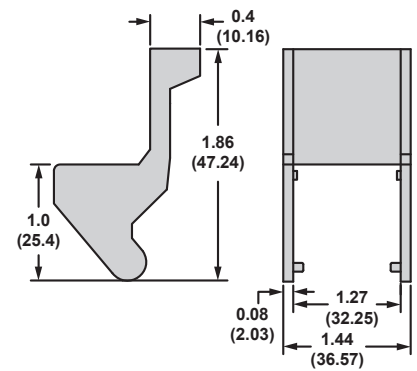

16-783SC

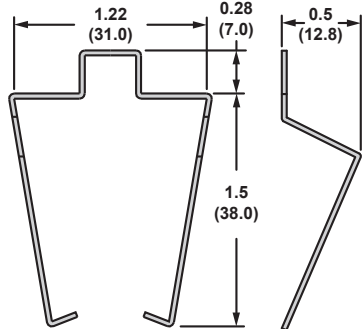

16-784IDC

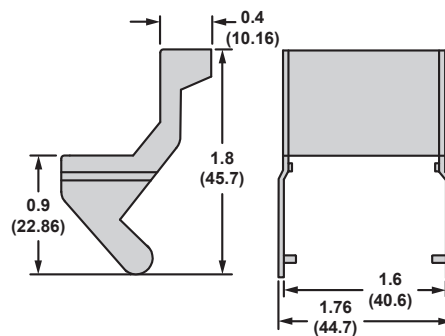

16-784SC

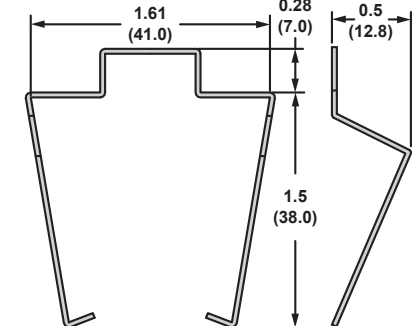

Hold-Down Clip Dimensions (*continued*) — inches (millimeters)

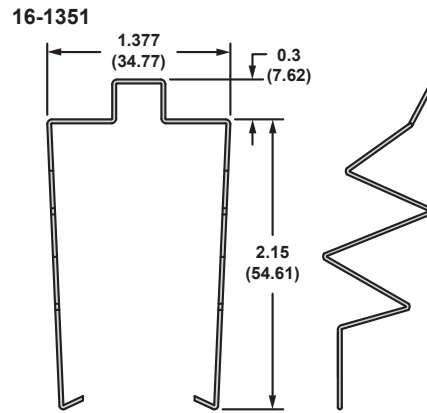
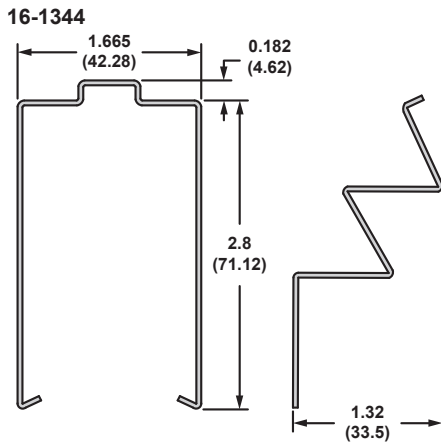
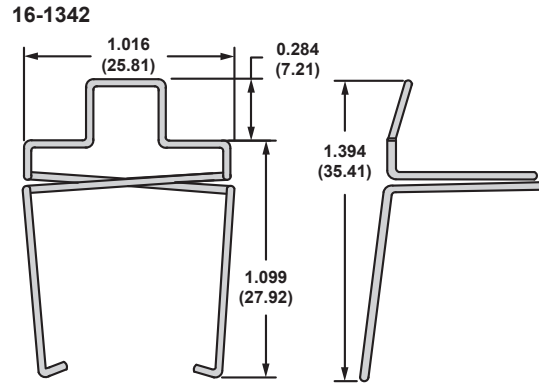
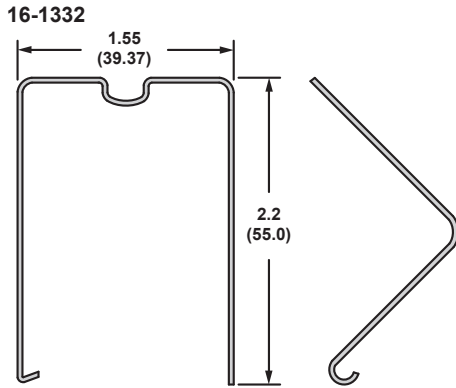

Insulated Coil Bus Jumper Dimensions — inches (millimeters)

16-750/788CBJ-1 Coil Bus Jumper

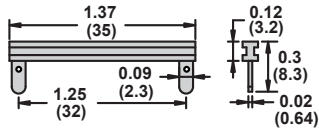

16-750/788CBJ-1 Coil Bus Jumper

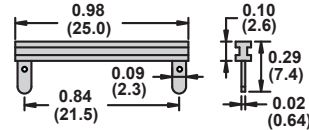

DIN Rail and DIN Clip Dimensions — inches (millimeters)

16-700DIN Metal DIN Rail

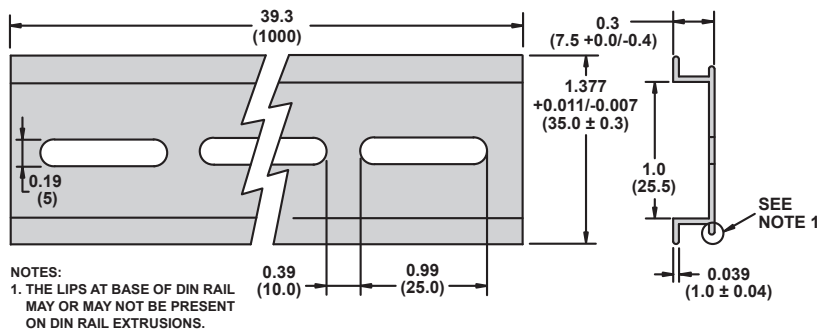

16-DCLIP-1 DIN Rail Clip

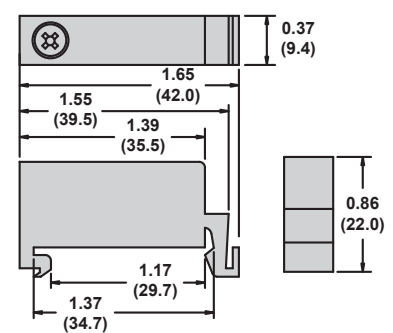

ID Tag Dimensions — inches (millimeters)

16-700ST-1 ID Tag/Label

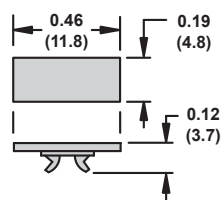

16-750/788FT-1 ID Tag/Label

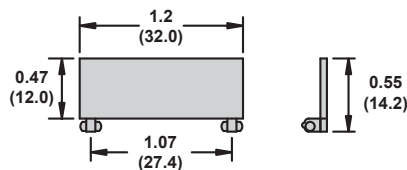

16-782FT-1 ID Tag/Label

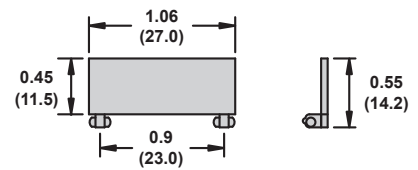

Panel Mount Adapter Dimensions — inches (millimeters)

16-788C1 Panel Mount Adapter

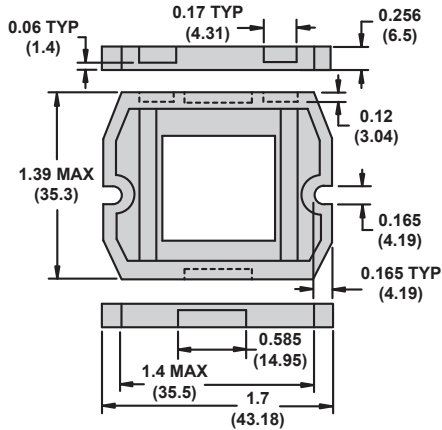

Socket Module Dimensions — inches (millimeters)

70-ASM Socket Modules

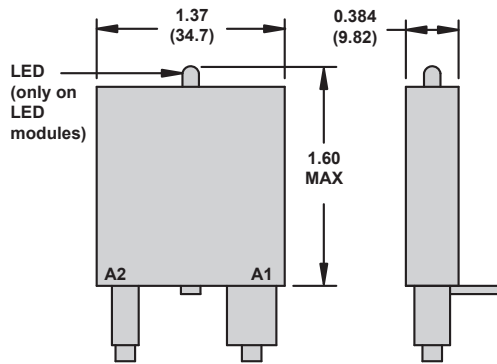

70-BSM Socket Modules

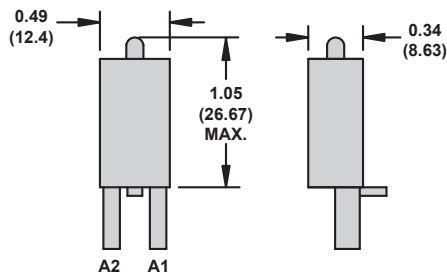

Socket Module Wiring Diagrams

70-ASM & 70-BSM Socket Modules

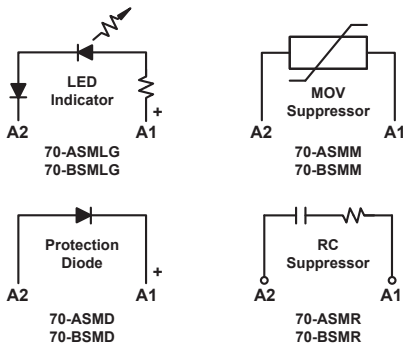

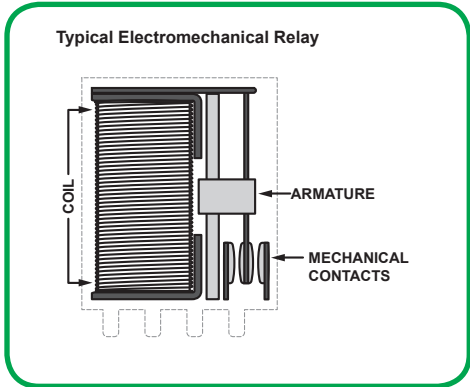

General Purpose Relays

General purpose relays are electromechanical relays which consist of a coil, armature and contacts (see figure at left).

Principle of Operation

When power is applied to the coil, the resulting magnetic field causes the armature to move and the contacts to open or close.

Latching Relays

Latching relays can be considered energy-saving relays due to the fact that power is not required to maintain contact closure. Applications using general purpose relays (such as pumps, compressors, fans and solar powered circuits) could use a fraction of the utility power by switching to a latching relay.

Principle of Operation

Magnetic Latching relays require one pulse of coil power to move their contacts in one direction, and another, redirected pulse to move them back. Repeated pulses from the same input have no effect. Magnetic Latching relays are useful in applications where interrupted power should not be able to transition the contacts.

Latching Relay Wiring Detail

Wire Setup	Wiring Diagrams		Relays
	Contacts Open	Contacts Closed	
<p>2-Wire, Alternating Polarity: The contacts transfer and reset when the voltage polarity is alternated into the single coil using two (2) control wires. Available for DC circuits only.</p>			785
<p>3-Wire: The contacts transfer and reset when the voltage is alternated between two (2) control wires while utilizing a third (common) wire. This single coil has internal diodes. Available for AC circuits only.</p>			755 785
<p>4-Wire: The contacts transfer and reset when the voltage is alternated between two (2) unique coils using four (4) control wires. Available for DC circuits only.</p>			755 785

Applications

With multiple options, features and available accessories, Magnecraft general purpose relays offer a complete system solution to improve your design, expedite installation and simplify testing of your application.

Typical Examples of General Purpose and Latching Relay Applications

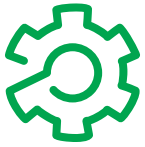

Automation Panels

Process controls, motor controls, standby lighting



Food & Beverage

Commercial/industrial cooking equipment, filtration systems, bottling, chillers, convection ovens



Packaging Machinery

Conveyor motors, food processors, product/shrink wrap, solenoid controls



Lighting Control

Traffic signal systems, motorway information systems, theatrical lighting, ballast lighting



Power Supplies

Universal power supplies, battery backup systems



Material Handling

Motor control, conveyor controls



HVAC & Refrigeration

Anti-condensation equipment, compressor controls, blower controls, motorized duct/vent controls



Appliances

Air conditioners, water heaters, portable heaters, spa controls, water pumps

The Magnecraft website (www.serelays.com) is designed to enable users to easily find the proper relay to fit design requirements and to help simplify and shorten workflow.

Easily find the proper relay to fit design requirements

■ Online Catalog

Find the right product by choosing specifications, compare products side-by-side, and view technical specifications, 2D and 3D drawings, and associated accessories.

■ Cross Reference Search

Search our comprehensive database to identify products by manufacturer and part number, and link directly to part specifications.

■ 3D CAD Library

View, email, download, or insert a file directly into your open CAD software. There are 18 different file formats to choose from.

■ Order Free Samples

Magnecraft offers free samples as a courtesy to individuals and companies evaluating our products for their designs and applications. Sample orders are subject to approval.

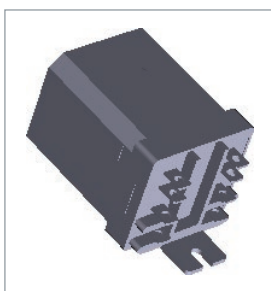

3D Models

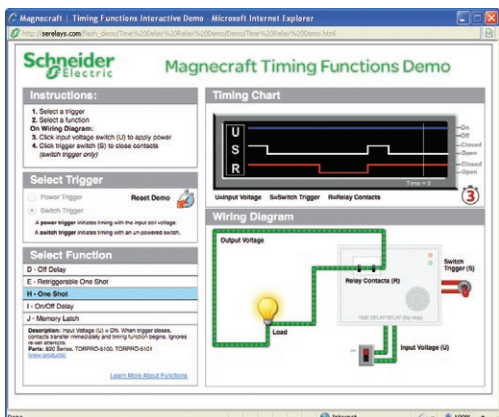

Time Delay Relay Demo

Simplify and shorten workflow

■ Interactive Tools

View interactive demonstrations; such as our Time Delay Relay Interactive Demo (left) which visually demonstrates the ten different timing functions offered on Magnecraft time delay relays.

■ Distributor Inventory Search

Search authorized distributors' current Magnecraft inventory and buy online. (Buy online not available for all distributors).

Schneider Electric USA, Inc.

1300 S. Wolf Rd.
Des Plaines, IL 60018
Tel: 847-441-2540
www.serelays.com

Electrical equipment should be installed, operated, serviced, and maintained only by qualified personnel. No responsibility is assumed by Schneider Electric for any consequences arising out of the use of this material.

© 2012–2014 Schneider Electric. All Rights Reserved.

Schneider Electric is a trademark owned by Schneider Electric Industries SAS or its affiliated companies. All other trademarks are the property of their respective owners.

8501CT1105R08/13, 02/2014
Replaces 8501CT1105 dated 01/2012