

W-Series Switch

Carling Technologies set the standard for performance and aesthetics with the widely successful, often imitated but never duplicated, V-Series rocker switches. Building further upon that platform, Carling has once again raised the bar with the fully sealed W-Series. The W-Series' traditional appearance features complete IP68 protection, including below the panel, where the critical connection is made from wiring harness. When used in conjunction with the integrated connector, the totally submersible W-Series provides a seal for up to ten individual wires, assuring compatibility with even the most complex circuitry.

The W-Series also offers a wide variety of accoutrements including endless illumination options featuring dual level and multicolor LEDs, progressive and hazard warning circuits, ratings up to 10A 24V, choice of paddle, rocker, locking or laser etched actuators, hundreds of standard legend choices and the electrical performance and reliability that is the hallmark of Carling Technologies products.



Key Features:

- ◆ Fully sealed and submersible
- ◆ IP68 protection including below the panel
- ◆ Tri-seal design
- ◆ Connector with twin locking tabs

Typical Applications:

- ◆ Marine equipment
- ◆ Transportation equipment



Carling Technologies™

Innovative Designs. Powerful Solutions.

W-Series Switch

DESIGN FEATURES

ILLUMINATION

Choice of highly reliable SMT LED or incandescent lighting with 21 dependent or independent circuit options.

TRI-SEAL DESIGN

Sealing at actuator, an insert molded neoprene base seal, along with wire lead seals, assures water tight, fully submersible protection.

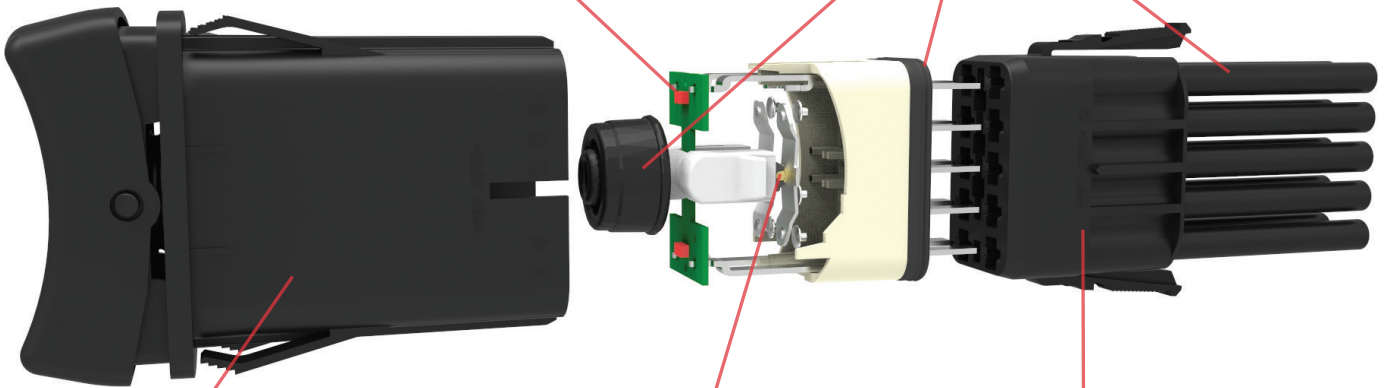

BODY

One piece polyester 94V0 seamless body acts as an umbrella to protect critical internal components.

ROLLER PIN

Proven reliable mechanism is lubricant free and allows for 100k electrical and 250k mechanical cycles, and withstands extreme temperatures from -40°C to +85°C.

INTEGRATED CONNECTOR

Accommodates Tyco/Amp .110 junior power timer contacts with twin locking tabs to provide a safe, secure, sealed connection.

Electrical

Contact Rating	.4VA @ 24VDC 10 amps, 3-24VDC
Dielectric Strength	1500 Volts RMS
Insulation Resistance	50 Megaohms
Initial Contact Resistance	10 milliohms max. @ 4 VDC
Life	100,000 cycles
Contacts	Silver tin-oxide, 88/12
Terminals	Copper with silver or gold plating.
Quick Connect	Connect terminations.
Voltage	3-24 VDC
Overcurrent	15A for 50 cycles

Mechanical

Endurance	250,000 cycles minimum
-----------	------------------------

Physical

Lighted	LED - rated 100,000 hours 1/2 life (LED is internally ballasted for voltages to 24 VDC)
Seals	Neoprene
Base	Polyester blend rated to 125C with a UL flammability rating of 94V0.
Actuator	Basic actuator structure molded of thermoplastic polycarbonate with a hard Nylon 66 thermoplastic surface overlay.
Lens	Polycarbonate rated at 100°C
Function	2 & 3 Position Rocker Style
Operation	Maintained & Momentary
Base	PA 6/6 30GF (glass filled)
Actuator	PA 6/6 13GF
Bracket	PBT 10GF
Connector	PBT 10GF, polarized

Actuator Travel (Angular Displacement)

24° full throw

Environmental

Environmental	IP68, Fully sealed
Corrosion/ Chemical Splash	Flowing Mixed Gas (FMG) Class III 3 year accelerated exposure per ASTM B-827, B-845 -40°C to +85°C, 22 cycles, 300 hours
Operating Temperature	Per Mil-Std 202F, Method 204D Test Condition A 0.06 DA or 10G's 10-500 Hz.
Vibration 1	Resonance search 24-50 Hz 0.40 DA 50-2000 ±10 G's peak Results Horizontal Axis 3-5 G's max.
Vibration 2	Random 24 Hz 0.06 PSD-Gsq/Hz 60 Hz 0.50 100 Hz 0.50 200 Hz 0.025 2000 Hz 0.025
Handling/Drop Salt Spray	One meter onto concrete floor Per Mil-Std 202F, Method 101D, Test Condition A, 48 Hrs.
Dust Thermal Shock	IP6X Per Mil-Std 202F, Method 107F, Test Condition A, -55°C to 85°C. Test criteria - pre and post test contact resistance
Moisture Resistance/ Humidity	Per Mil-Std 202F, Method 106F, Test Criteria - pre and post test contact resistance

Mounting Specifications

Panel Thickness Range .032 to .125

For optimum panel fit, the following panel thicknesses are suggested: .032, .062, .093, .125

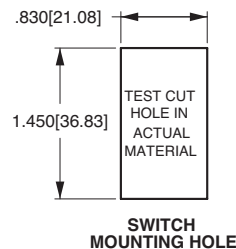

*Manufacturer reserves the right to change product specification without prior notice.

W
11
D
2
B
C
0
1
-
A
7
Z
00
-
0
00

1 Series 2 Circuit 3 Rating 4 Termination 5 Illumination 6 Lamp 7 Lamp 8 Bracket 9 Actuator 10 Lens 11 Lens 12 Legend 13 Legend 14 Actuator
 Orientation Lens Legend

1 SERIES
W

2 CIRCUIT
Terminal Connections as viewed from bottom of switch: () - momentary

8 terminal	10 terminal	SP - single pole - uses terminals 1, 2 & 3.
8 - - 7	8 - - 7	DP - double pole uses terminals 1, 2, 3, 4, 5 & 6.
1 - - 4	1 - - 4	Terminals 7, 8, 9 & 10 for lamp circuit only.
2 - - 5	2 - - 5	
3 - - 6	3 - - 6	
	10 - - 9	

Position:

SP	DP	1	2	3
11	21	2 & 3, 6 & 8	Connected Terminals	1 & 2, 5 & 6
12	22	ON	NONE	OFF
13	23	ON (ON)	NONE	OFF
14	24	ON	NONE	(OFF)
15	25	ON	NONE	ON
16	26	ON	NONE	(ON)
17	27	ON	OFF	ON
18	28	ON (ON)	OFF	(ON)
-	49	ON	ON	ON

3 RATING

B	10A 24V
D	10A 12V
G	10A 6V
H	10A 3V

4 TERMINATION/BASE STYLE

2 .110 TAB (QC)

5 ILLUMINATION
Lamp #1: above terminals 1&4 end of switch.; Lamp #2 above terminals 3&6 end of switch. Positive (+) and negative (-) symbols apply to LED lamps only

	Lamps	Actuator Lens Position Illumination Type	Lamp wired to Terminals	
O	NONE			
A	# 1	Independent	8+	7-
B	# 1	Down	3+	7-
C	# 2	Up	3+	7-
D	# 1	Down	3+	7-
E	# 1	Up	1+	7-
F	# 1	Independent	8+	7-
G	# 1	Independent	8+	7-
H	# 2	Independent	8+	7-
J	# 1	Down	3+	8-
K	# 1	Independent	8+	7-
L	# 1	Down	3+	6-
M	# 2	Up	3+	6-
N	# 1	Down	3+	6-
P	# 1	Up	1+	4-
R	# 1	Down	3+	7-
S	# 1	Down	6+	7-
U	# 1	Independent	8+	7-
V	# 2	Independent	8+	7-
W	# 1	Independent	10+	9-
Y	# 1 & 2	Independent in Series	8+	7-
Z	# 1 & 2	Independent in Parallel	8+	7-

6,7 LAMP (SAME CODING FOR BOTH SELECTIONS)
Selection 6: above terminals 1 & 4; Selection 7: above terminals 3 & 6

No lamp 0

LED*

2VDC	Red	Amber	superbright Green	White
6VDC	A	L	F	4
12VDC	B	M	G	5
24VDC	C	N	H	6
	D	P	J	8

* Consult factory for "daylight bright", blue/green and white LED options. Typical current draw for LED is 20ma.

8 BRACKET COLOR¹

1 Black

9 ACTUATOR^{1,3}

3 Black with Laser Etch
A Black

10 LENS - ABOVE LAMP #1 TERMINALS^{1,4}
11 LENS - ABOVE LAMP #2 TERMINALS^{3,6}

Lens color for LEDs must be clear, white, or match color of LED.

0 - No Actuator Z - No Lens

Clear	White	Amber	Green	Red	Blue	
1	-	B	G	M	T	Large Transparent
-	7	C	H	N	U	Large Translucent
3	-	D	J	P	V	Bar Transparent
-	9	E	K	R	W	Bar Translucent
5	A	-	-	-	-	Laser Etch background color

12 ACTUATOR LENS OR BODY LEGEND²

00 - No Legend this location/No actuator

11	ON	12	OFF	13	I	14	O
	OFF		ON		O		I
15	O	16	O	17	O	18	I
	F		N		F		
21		22		23		24	
	OFF		ON		O		I
25	O	26	O	27	O	28	I
	F		N				

For additional legend options & codes, visit us at carlingtech.com

13 LEGEND ORIENTATION

0 No legend (used with codes 11-18 in selection 12)

1 Orientation 1

2 Orientation 2

3 Orientation 3

4 Orientation 4

14 ACTUATOR LENS LEGEND²

00 No legend this location/no actuator (used with codes 11-18 in selection 12)

Selection 14 required when switch requires two legends. If the two legends consist of one lens & one body legend, lens legend must be specified in selection 12; body legend specified in selection 14. For legend options & codes, visit us at carlingtech.com

Notes:

- Custom colors are available. Consult factory.
- White imprinting is standard on black actuators; Black imprinting is standard on white, red & gray actuators; Custom colors are available, consult factory.
- Locking rocker version is also available, consult factory for details.

Dimensional Specifications: in. [mm]

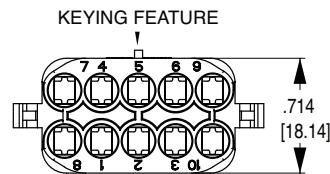
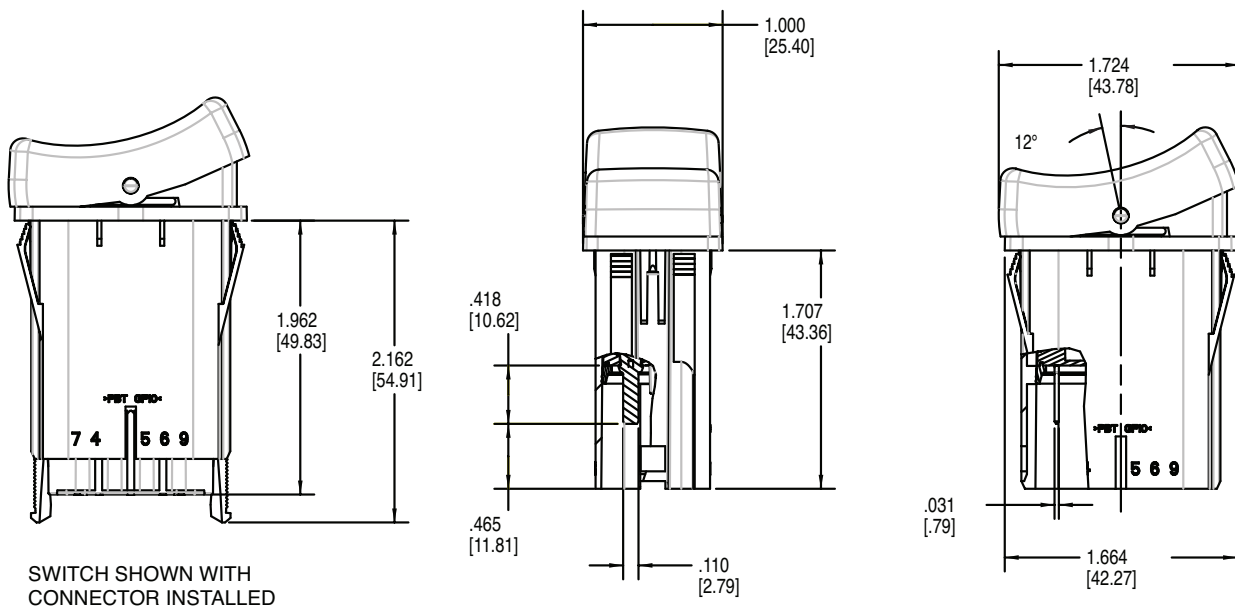
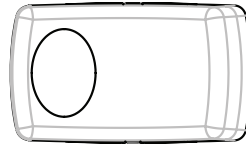

WCH CONNECTOR
(190-31214-001)

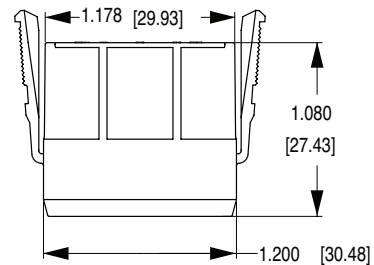

Notes:
 WCH connector is intended for use with Tyco/Amp .110 Junior Power Timer, female contacts, and wire seals.
 For 14-16 awg wire, specify Tyco/Amp P/N 927766-3
 For 16-20 awg wire, specify Tyco/Amp P/N 927770-3
 Tyco/Amp cable seal P/N 828904-1 (20-18 awg wire) or P/N 828905-1 (16-14 awg wire) is required for each individual wire lead, and Tyco/Amp cable plug, P/N 828922-1, is required to seal each unused connector opening. Consult Tyco/Amp for the cable seal recommended for your specific wire gauge and thickness.

Worldwide Headquarters

Carling Technologies, Inc.
60 Johnson Avenue • Plainville, CT 06062-1177
Phone: (860) 793-9281 • Fax: (860) 793-9231
Email: sales@carlingtech.com • www.carlingtech.com

East Region Sales Office, CT • ersm@carlingtech.com
Midwest Region Sales Office, IL • mrs@carlingtech.com
West Region Sales Office, CA • wrsm@carlingtech.com

Asia-Pacific Headquarters

Carling Technologies, Asia-Pacific Ltd.,
Kowloon, Hong Kong
Int + 852-2737-2277 • Fax: Int + 852-2736-9332
Email: sales@carlingtech.com.hk

Shenzhen, China • shenzhen@carlingtech.com
Shanghai, China • shanghai@carlingtech.com
Pune, India • india@carlingtech.com
Kaohsiung, Taiwan • taiwan@carlingtech.com
Yokohama, Japan • japan@carlingtech.com

Europe / Middle East / Africa Headquarters

Carling Technologies LTD
4 Airport Business Park, Exeter Airport,
Clyst Honiton, Exeter, Devon, EX5 2UL, UK
Int + 44 1392-364422 • Fax: Int + 44 1392-364477
Email: ltd.sales@carlingtech.com

GmbH, Germany • gmbh@carlingtech.com
SAS, France • sas@carlingtech.com

REV_SW_W_06_2013



Carling Technologies™

Innovative Designs. Powerful Solutions.

Innovative Designs. Powerful Solutions.