

**SERIES:** VYB10W-T | **DESCRIPTION:** DC-DC CONVERTER

**FEATURES**

- chassis mount with screw terminal connectors
- up to 10 W output
- compact size
- 4:1 input range (9 ~ 36 V, 18 ~ 72 V)
- single and dual outputs
- 1,500 V isolation
- short circuit protection
- wide temperature operation (-40 ~ 85°C)
- efficiency up to 83%



MODEL	input voltage range (Vdc)	output voltage (Vdc)	output current		output power max (W)	ripple <sup>1</sup> max (mVp-p)	noise <sup>1</sup> max (mVp-p)	efficiency typ (%)
			min (mA)	max (mA)				
VYB10W-Q24-S3-T <sup>2</sup>	9 ~ 36	3.3	240	2,400	8	50	150	76
VYB10W-Q24-S5-T	9 ~ 36	5	200	2,000	10	50	150	79
VYB10W-Q24-S12-T	9 ~ 36	12	83	833	10	50	150	81
VYB10W-Q24-S15-T	9 ~ 36	15	67	666	10	50	150	82
VYB10W-Q24-D5-T	9 ~ 36	±5	±100	±1,000	10	50	150	80
VYB10W-Q24-D12-T	9 ~ 36	±12	±42	±416	10	50	150	82
VYB10W-Q24-D15-T	9 ~ 36	±15	±33	±333	10	50	150	83
VYB10W-Q48-S3-T <sup>2</sup>	18 ~ 72	3.3	240	2,400	8	50	150	77
VYB10W-Q48-S5-T <sup>2</sup>	18 ~ 72	5	200	2,000	10	50	150	78
VYB10W-Q48-S12-T	18 ~ 72	12	83	833	10	50	150	82
VYB10W-Q48-S15-T	18 ~ 72	15	67	666	10	50	150	83
VYB10W-Q48-D5-T <sup>2</sup>	18 ~ 72	±5	±100	±1,000	10	50	150	78
VYB10W-Q48-D12-T	18 ~ 72	±12	±42	±416	10	50	150	82
VYB10W-Q48-D15-T	18 ~ 72	±15	±33	±333	10	50	150	83

Notes: 1. Ripple and noise are measured at 20 MHz BW with 10µF tantalum capacitor and 1µF ceramic capacitor across output  
2. PWM mode, others PFM mode

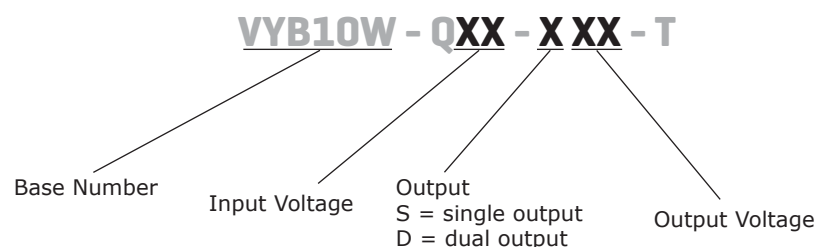
**PART NUMBER KEY**

## INPUT

parameter	conditions/description	min	typ	max	units
operating input voltage		9	24	36	Vdc
		18	48	72	Vdc

## OUTPUT

parameter	conditions/description	min	typ	max	units
line regulation	measured from low line to high line		±0.2	±0.5	%
load regulation	measured from 10% to full load		±0.5	±1 <sup>1</sup>	%
voltage accuracy	positive, refer to recommended circuit negative, refer to recommended circuit		±1	±3	%
			±3	±5	%
switching frequency	100% load, input voltage range		300		kHz
temperature coefficient				±0.03	%/°C

Notes: 1. Dual output models unbalanced load: ±5%

## PROTECTIONS

parameter	conditions/description	min	typ	max	units
short circuit protection	continuous, automatic recovery				

## SAFETY AND COMPLIANCE

parameter	conditions/description	min	typ	max	units
isolation voltage	tested for 1 minute at 1 mA max.	1,500			Vdc
isolation resistance	at 500 Vdc	1,000			MΩ
isolation capacitance	input to output, 100 kHz / 1 V		1,000		pF
RoHS compliant	yes				
MTBF		1,000,000			hours

## ENVIRONMENTAL

parameter	conditions/description	min	typ	max	units
operating temperature	see derating curve	-40		100	°C
storage temperature		-55		125	°C
storage humidity	non-condensing			95	%
temperature rise	100% load		40		°C

## DERATING CURVES

output power vs. ambient temperature

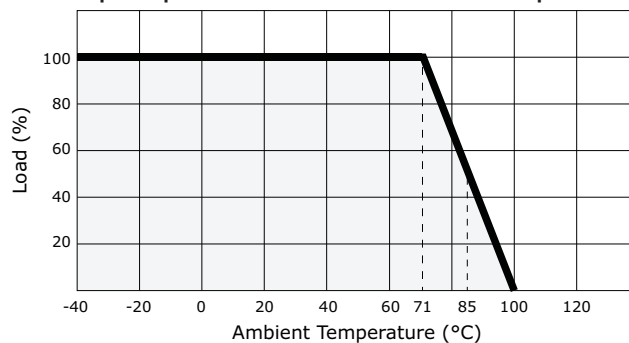

## MECHANICAL

parameter	conditions/description	min	typ	max	units
dimensions	55.0 x 52.3 x 19.1 (2.17 x 2.06 x 0.75 inch)				mm
case material	aluminum				
weight			50		g

## MECHANICAL DRAWING

units: mm [inch]

tolerance:  $\pm 0.5$  [ $\pm 0.020$ ] unless otherwise specified

screw terminals: Degson Electronics terminal block part number DG301-5.0-04P-12 or equivalent (4 pin, M2.5 screw) 5.0 mm spacing DIN rail mounting kit available (part # STK-DIN)

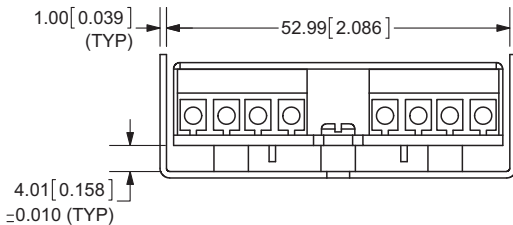
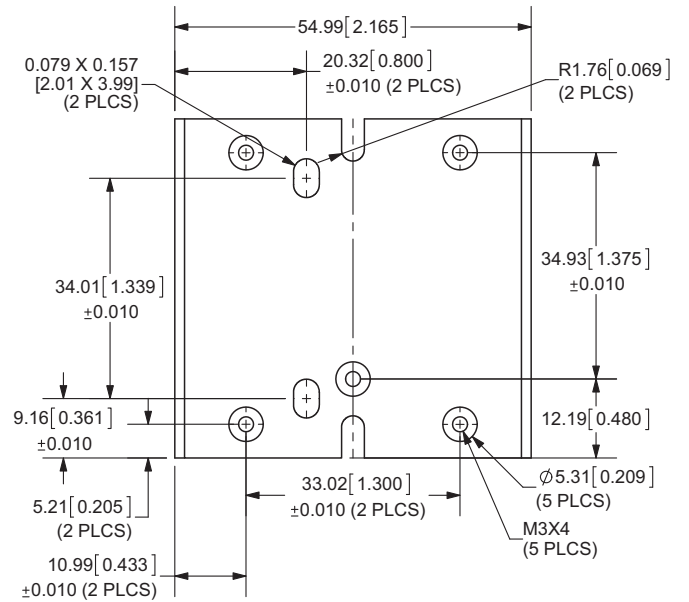
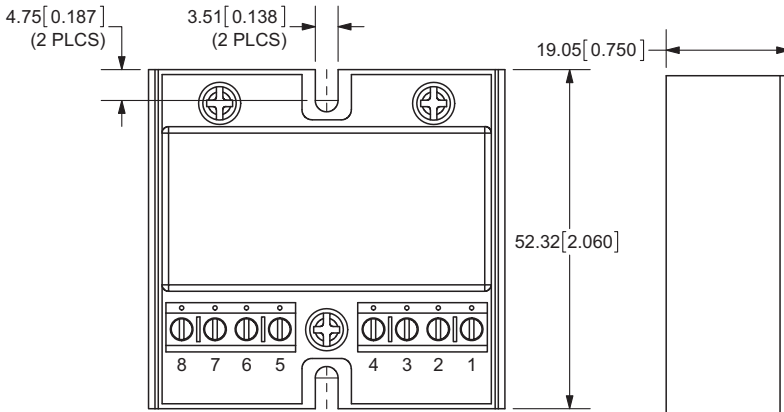
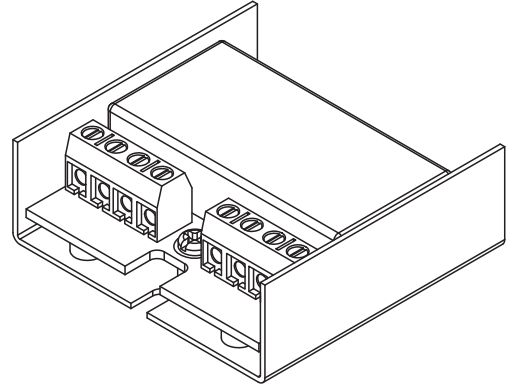

PIN CONNECTIONS		
Pin	Single	Dual
1	0V	-Vo
2	No Pin	0V
3	+Vo	+Vo
4	No Pin	No Pin
5	Case	Case
6	No Pin	No Pin
7	Vin	Vin
8	GND	GND

## APPLICATION NOTES

### 1. Requirement on Output Load

In order to ensure the product operates efficiently and reliably, make sure the specified range of input voltage is not exceeded and the minimum output load is not less than 10% load. If the actual load is less than the specified minimum load, the output ripple may increase sharply while its efficiency and reliability will reduce greatly. If the actual output power is very small, please add an appropriate resistor as extra loading.

### 2. Recommended Circuit

The VYB10W series has been tested according to the following recommended testing circuit. This series should be tested under load. (see Figure 1)

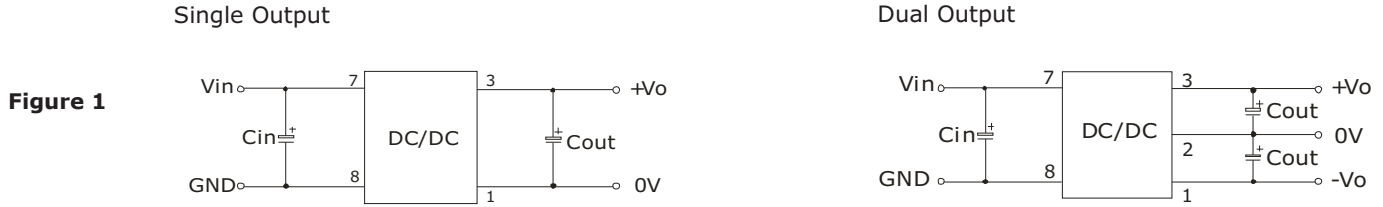

If you want to further decrease the input/output ripple, you can increase capacitance properly or choose capacitors with low ESR. If the capacitance is too big, a startup problem might arise. The maximum allowable capacitance to ensure safe and reliable operation is listed in Table 1.

General:

Cin: 10 ~ 47  $\mu$ F  
 Cout: 10  $\mu$ F / 100 mA

Table 1

Single Vout (Vdc)	Cout ( $\mu$ F)	Dual Vout (Vdc)	Cout ( $\mu$ F)
3.3	2,200	--	--
5	1,000	$\pm$ 5	680
12	470	$\pm$ 12	330
15	330	$\pm$ 15	220

### 3. Input Current

When using an unstable power source, please ensure the output voltage and ripple voltage do not exceed indexes of the converter. The preceding power source must be able to provide for converter sufficient starting current  $I_p$ .

General:  $I_p \leq 1.6 * I_{in-max}$

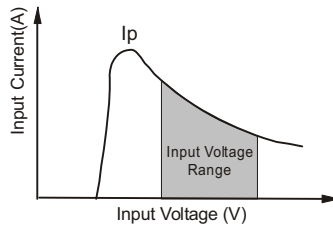

Figure 2

Notes: 1. Operation under minimum load will not damage the converter; however, they may not meet all specifications listed.  
 2. All specifications measured at:  $T_a=25^\circ\text{C}$ , humidity<75%, nominal input voltage and rated output load, unless otherwise specified.  
 3. No parallel connection

## REVISION HISTORY

---

rev.	description	date
1.0	initial release	08/08/2011
1.01	V-Infinity branding removed	08/29/2012
1.02	removed on/off control option, updated spec	04/05/2013

The revision history provided is for informational purposes only and is believed to be accurate.



**CUI INC**<sup>®</sup>

**Headquarters**  
20050 SW 112th Ave.  
Tualatin, OR 97062  
**800.275.4899**

Fax 503.612.2383  
**cui.com**  
techsupport@cui.com

CUI offers a two (2) year limited warranty. Complete warranty information is listed on our website.

CUI reserves the right to make changes to the product at any time without notice. Information provided by CUI is believed to be accurate and reliable. However, no responsibility is assumed by CUI for its use, nor for any infringements of patents or other rights of third parties which may result from its use.

CUI products are not authorized or warranted for use as critical components in equipment that requires an extremely high level of reliability. A critical component is any component of a life support device or system whose failure to perform can be reasonably expected to cause the failure of the life support device or system, or to affect its safety or effectiveness.