

NON-ISOLATED DC/DC CONVERTERS

4.5 Vdc - 13.8 Vdc Input

0.59 Vdc - 5.1 Vdc / 10 A Output

Dec 30, 2015

Bel Power, Inc. , a subsidiary of Bel Fuse, Inc.

VRAE-10E1A1

RoHS Compliant

Rev.C

- Non-Isolated
- High Efficiency
- Fixed Frequency
- Low Cost
- Wide Input
- Class 2, Category 2, Isolated DC/DC Converter (refer to IPC-9592B)
- UL60950-1,-2 2nd Edition Recognized (UL/cUL)
- Under-Voltage Lockout
- Wide Trim
- OCP/SCP
- Remote On/Off

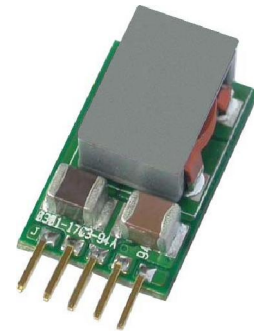

Description

The Bel VRAE-10E1A1 is part of the non-isolated dc/dc converter Power Module series. The modules use a SIP package. These converters are available in a range of output voltages from 0.59 Vdc to 5.1 Vdc over a wide range of input voltage ($V_{IN} = 4.5 \text{ Vdc} - 13.8 \text{ Vdc}$). The efficiency is typically 91% at 3.3 Vout ($V_{in}=12 \text{ Vdc}$) at full load.

Part Selection

Output Voltage	Input Voltage	Max. Output Current	Max. Output Power	Typical Efficiency	Model Number Active High
0.59 Vdc - 5.1 Vdc	4.5 Vdc - 13.8 Vdc	10 A	50 W	91%	VRAE-10E1A1

Notes: 1. All part numbers above indicate RoHS 6. Change the second letter "R" to "7" for RoHS 5 part numbers.
2. Add "G" suffix at the end of the model numbers listed above to indicate "Tray Packaging".

Part Number Explanation

$\frac{V}{1} \frac{R}{2} \frac{AE}{3} - \frac{10}{4} \frac{E}{5} \frac{1A}{6} \frac{1}{7} \frac{y}{8}$

- 1---Vertical mount
- 2---RoHS 6, change "R" to "7" means RoHS 5
- 3---Series name, SIP
- 4---Series code
- 5--- Wide input range (4.5-13.8V)
- 6---Wide output range (0.59-5.1V)
- 7---Suffix
- 8---Package

NON-ISOLATED DC/DC CONVERTERS

4.5 Vdc - 13.8 Vdc Input

0.59 Vdc - 5.1 Vdc / 10 A Output



Dec 30, 2015

Bel Power, Inc. , a subsidiary of Bel Fuse, Inc.

Absolute Maximum Ratings

Parameter	Min	Typ	Max	Notes
Input Supply Voltage	-0.3 V	-	15 V	
Ambient Temperature	0 °C	-	70 °C	
Storage Temperature	-55 °C	-	125 °C	
Altitude	-	-	2000 m	

Note: All specifications are typical at 25 °C unless otherwise stated.

Input Specifications

Parameter	Min	Typ	Max	Notes
Operating Input Voltage				
$V_{o,set} \leq 3.63$ V	4.5 V	-	13.8 V	
$V_{o,set} > 3.63$ V	7.0 V	-	13.8 V	
Input Current (full load)	-	-	8.5 A	An input line fuse must always be used.
Input Current (no load)	-	-	120 mA	
Remote Off Input Current	-	10 mA	25 mA	
Input Reflected Ripple Current (pk-pk)	-	30 mA	100 mA	With simulated source impedance of 1000 nH, 5 Hz to 20 MHz. Use a 1000 uF/25 V AL-Cap with ESR=0.03 ohm max and 2*100 uF/25V Tan-Cap with ESR=0.013 ohm max at 100 kHz@25°C.
Input Reflected Ripple Current (rms)	-	15 mA	30 mA	
I ² t Inrush Current Transient	-	-	1 A ² s	
Turn on Voltage Threshold	4.15 V	4.3 V	4.45 V	A 30.1K resistor is connected from Enable to Vin
Turn off Voltage Threshold	3.7 V	4.1 V	4.3 V	

Note: All specifications are typical at 25 °C unless otherwise stated.

NON-ISOLATED DC/DC CONVERTERS

4.5 Vdc - 13.8 Vdc Input

0.59 Vdc - 5.1 Vdc / 10 A Output



Dec 30, 2015

Bel Power, Inc., a subsidiary of Bel Fuse, Inc.

Output Specifications

Parameter	Min	Typ	Max	Notes	
Output Voltage Set Point Accuracy	-2%Vo,set	-	2%Vo,set	Vin= 12 V, Iout=full load	
Load Regulation	-	±0.3%Vo,set	±1%Vo,set		
Line Regulation	-	±0.3%Vo,set	±1%Vo,set		
Temperature Regulation	-	0.3%Vo,set	-		
Output Current	0 A	-	10 A		
Output DC Current Limit	10.2 A	13 A	15 A		
Output Ripple and Noise (pk-pk)	-	70 mV	100 mV	0-20 MHz BW, with a 1 uF ceramic and a 10 uF tantalum capacitor at the output.	
Output Ripple and Noise (rms)	-	20 mV	30 mV		
Short Circuit Surge Transient	-	-	5 A ² s		
Turn on Time	-	-	7 mS		
Overshoot at Turn on	-	-	1%		
Output Capacitance	0 uF	-	1000 uF		
Transient Response					
50% ~ 100% Max Load	Vo =All	-	120 mV	200 mV	di/dt=0.25 A/uS; Vin= 12 V; with a 10 uF tantalum capacitor and a 1 uF ceramic capacitor at the output.
Settling Time		-	30 uS	50 uS	
100% ~ 50% Max Load		-	120 mV	200 mV	
Settling Time		-	30 uS	50 uS	

Note: All specifications are typical at normal input, full load at Ta= 25°C unless otherwise stated.

General Specifications

Parameter	Min	Typ	Max	Notes
Efficiency				Vin=12 V
Vo=5.0 V	91%	93%	-	
Vo=3.3 V	89%	91%	-	
Vo=2.5 V	87%	89%	-	
Vo=1.8 V	84%	86%	-	
Vo=1.5 V	83%	85%	-	
Vo=1.2 V	80%	82%	-	
Vo=0.9 V	73%	75%	-	
Switching Frequency	-	500 kHz	-	
Output Voltage Trim Range (Wide Trim)	0.591 V	-	5.1 V	
MTBF	7,677,401 hours			Calculated Per Bell Core SR-332 (Io = 80% load; Vin=12 V; Vo=5 V; 200 LFM; Ta = 25 °C)
Dimensions				
Inches (L × W × H)	0.65 x 0.41 x 0.32			
Millimeters (L × W × H)	16.51 x 10.41 x 8.13			
Weight	-	3.5 g	-	

Note: All specifications are typical at 25 °C unless otherwise stated.

NON-ISOLATED DC/DC CONVERTERS

4.5 Vdc - 13.8 Vdc Input

0.59 Vdc - 5.1 Vdc / 10 A Output



Dec 30, 2015

Bel Power, Inc. , a subsidiary of Bel Fuse, Inc.

Control Specifications

Parameter	Min	Typ	Max	Notes
Remote On/Off				
Signal Low (Unit Off)	-0.3 V	-	0.4 V	Remote On/Off Pin is open, the unit is off.
Signal High (Unit On)	2.0 V	-	5.5 V	

Output Trim Equations

Equation for calculating the trim resistor given the desired output voltage (V_o) is shown below. The R_{trim} resistor should be connected between the trim pin and GND pin.

$$R_{trim} = \frac{1.182}{V_o - 0.591} k\Omega$$

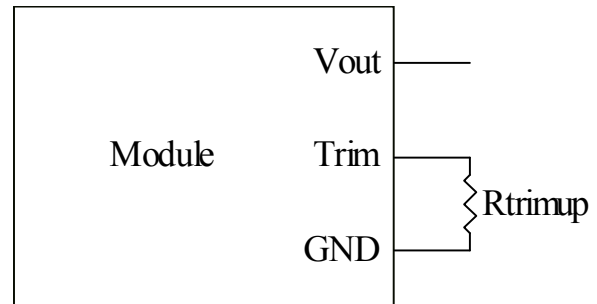

NON-ISOLATED DC/DC CONVERTERS

4.5 Vdc - 13.8 Vdc Input

0.59 Vdc - 5.1 Vdc / 10 A Output



Dec 30, 2015

Efficiency Data

Bel Power, Inc. , a subsidiary of Bel Fuse, Inc.

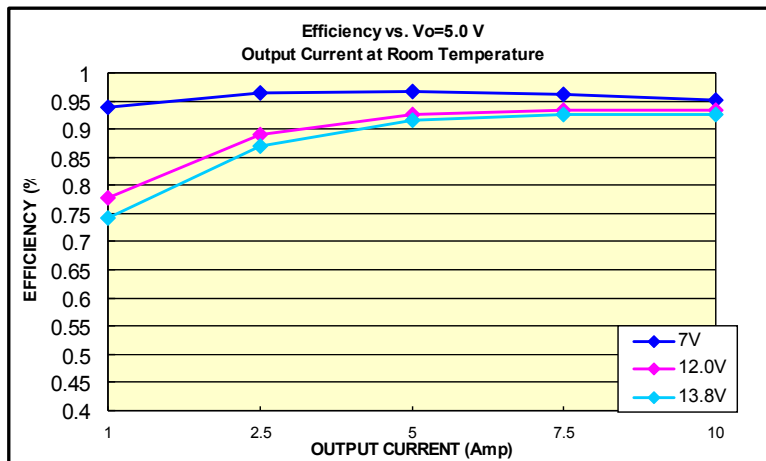
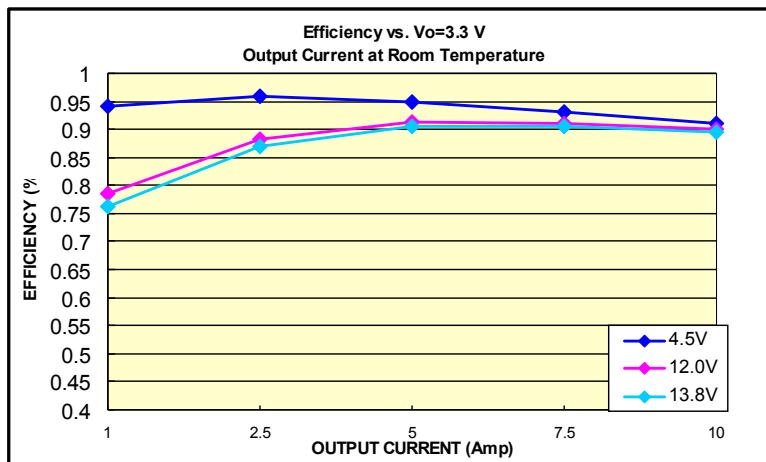
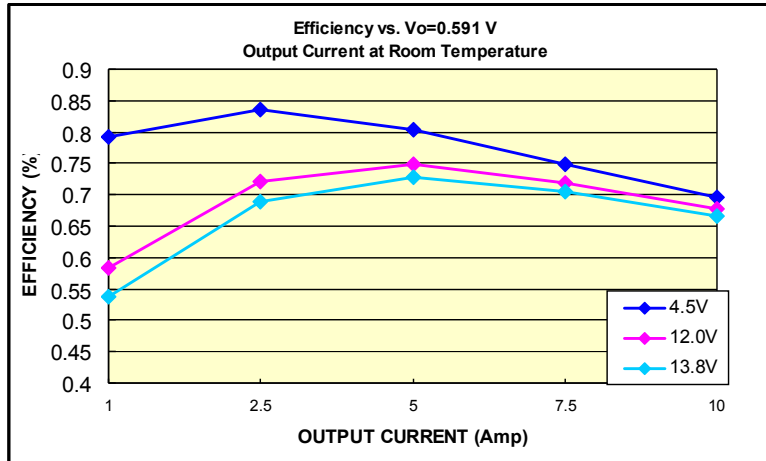

NON-ISOLATED DC/DC CONVERTERS

4.5 Vdc - 13.8 Vdc Input

0.59 Vdc - 5.1 Vdc / 10 A Output



Dec 30, 2015

Bel Power, Inc., a subsidiary of Bel Fuse, Inc.

Thermal Derating Curves

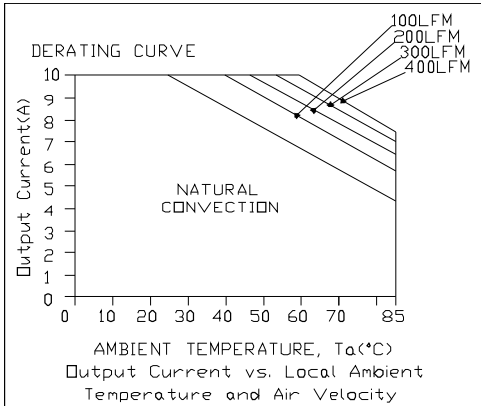

Vin=12 V, Vout=5 V

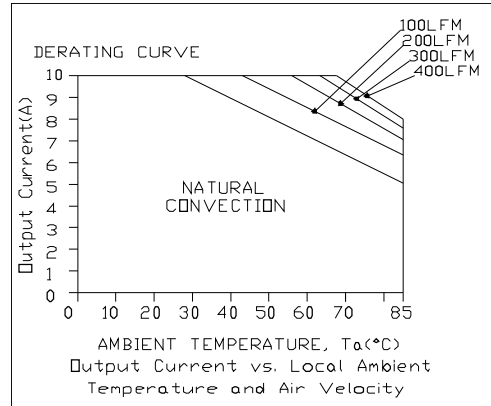

Vin=12 V, Vout=3.3 V

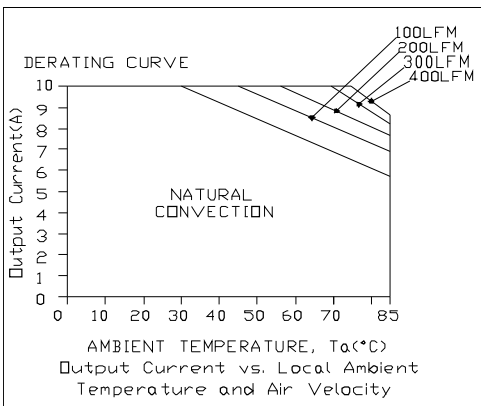

Vin=12 V, Vout=2.5 V

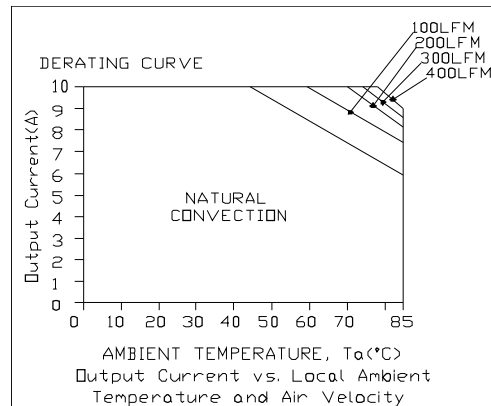

Vin=12 V, Vout=1.2 V

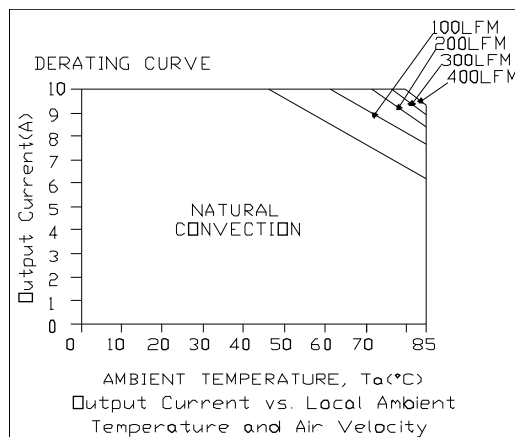

Vin=12 V, Vout=0.59 V

NON-ISOLATED DC/DC CONVERTERS

4.5 Vdc - 13.8 Vdc Input

0.59 Vdc - 5.1 Vdc / 10 A Output



Dec 30, 2015

Bel Power, Inc., a subsidiary of Bel Fuse, Inc.

Ripple and Noise Waveforms

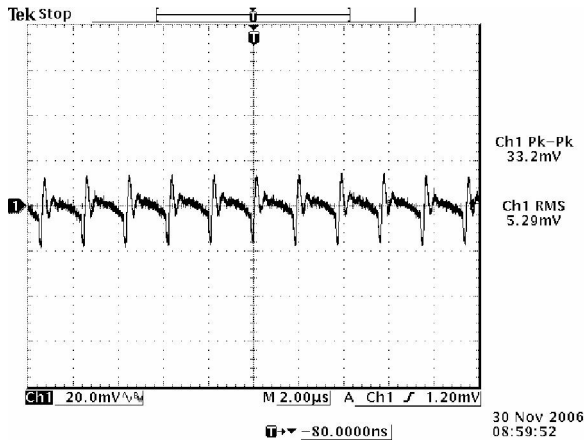

12 V input, 0.591 V output

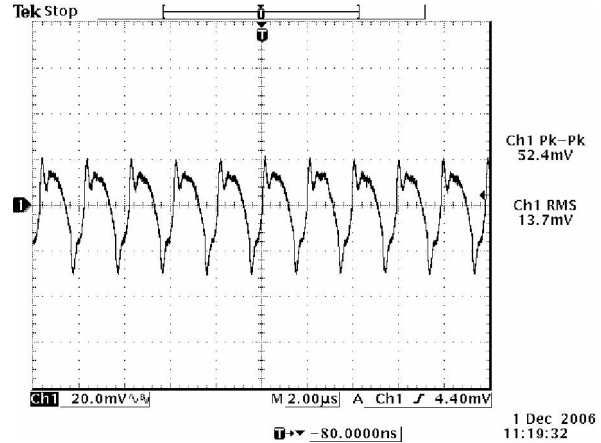

12 V input, 3.3 V output

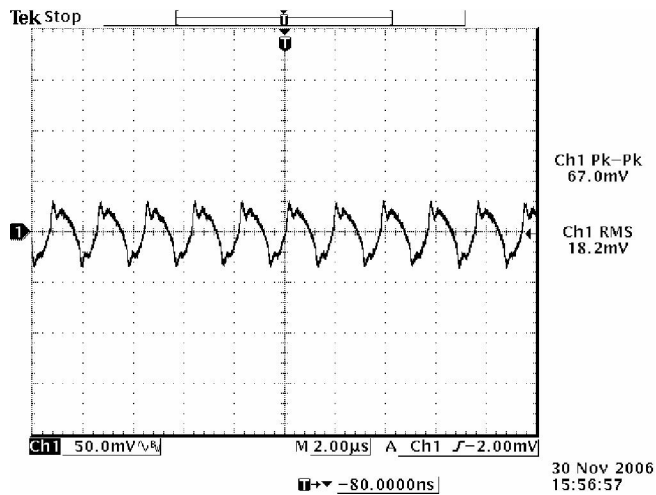

12 V input, 5.0 V output

Note: Ripple and noise at full load, 0-20MHz BW, with a 1 uF ceramic and a 10 uF tantalum capacitor at the output, Ta=25 deg C.

NON-ISOLATED DC/DC CONVERTERS

4.5 Vdc - 13.8 Vdc Input

0.59 Vdc - 5.1 Vdc / 10 A Output



Dec 30, 2015

Bel Power, Inc., a subsidiary of Bel Fuse, Inc.

Transient Response Waveforms

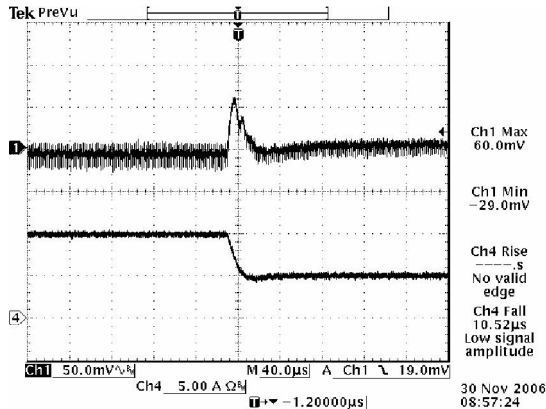

100% to 50% load step at 12 V input, 0.591 V output

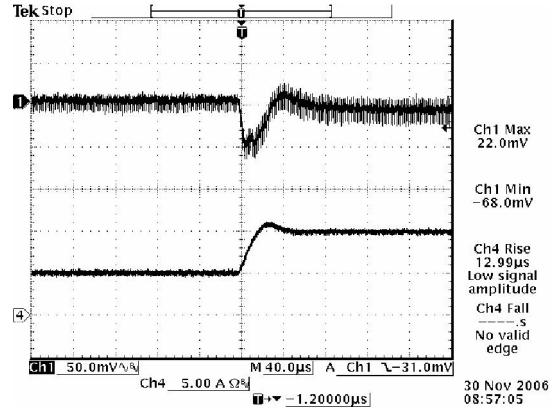

50% to 100% load step at 12 V input, 0.591 V output

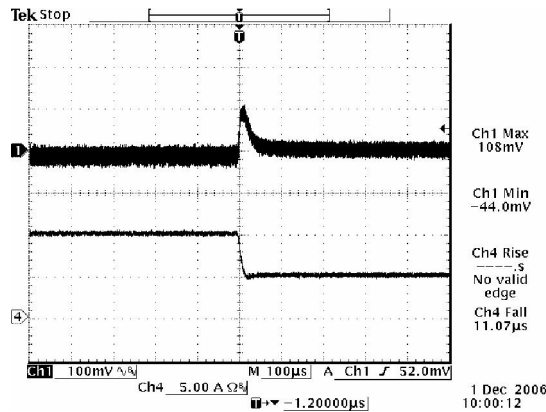

100% to 50% load step at 12 V input, 3.3 V output

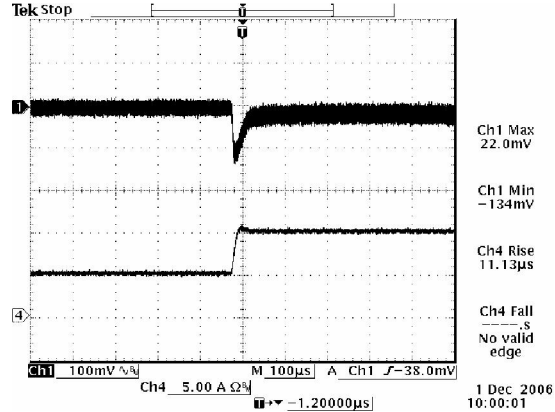

50% to 100% load step at 12 V input, 3.3 V output

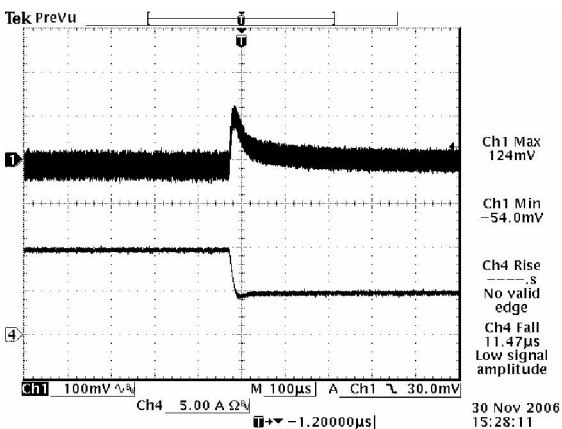

100% to 50% load step at 12 V input, 5.0 V output

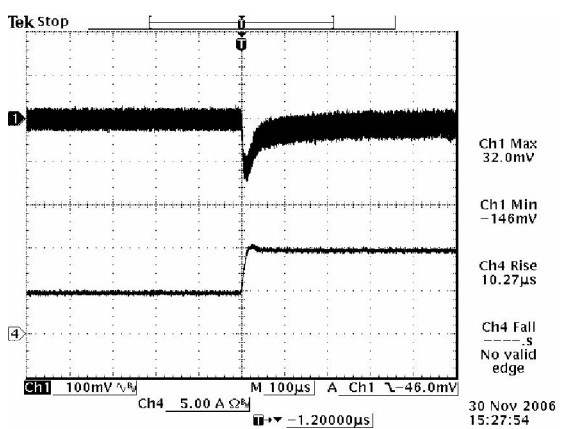

50% to 100% load step at 12 V input, 5.0 V output

Note: Transient response at $di/dt=0.25$ A/ μ s, with a 1 μ F ceramic cap and a 10 μ F tantalum cap at the output, and $T_a=25$ deg C.

NON-ISOLATED DC/DC CONVERTERS

4.5 Vdc - 13.8 Vdc Input

0.59 Vdc - 5.1 Vdc / 10 A Output



Dec 30, 2015

Bel Power, Inc. , a subsidiary of Bel Fuse, Inc.

Assembly Note

Modules were designed for vertical insertion into host board. Experiments should be performed to make sure that the units meet the intended tilt specification. A fixture may be needed to make the module stand upright in assembly

Mechanical Outline

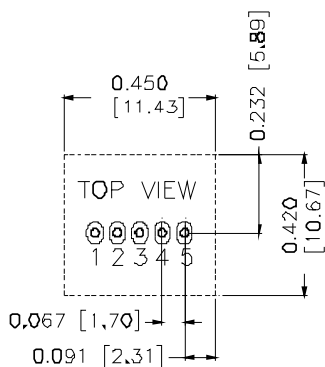
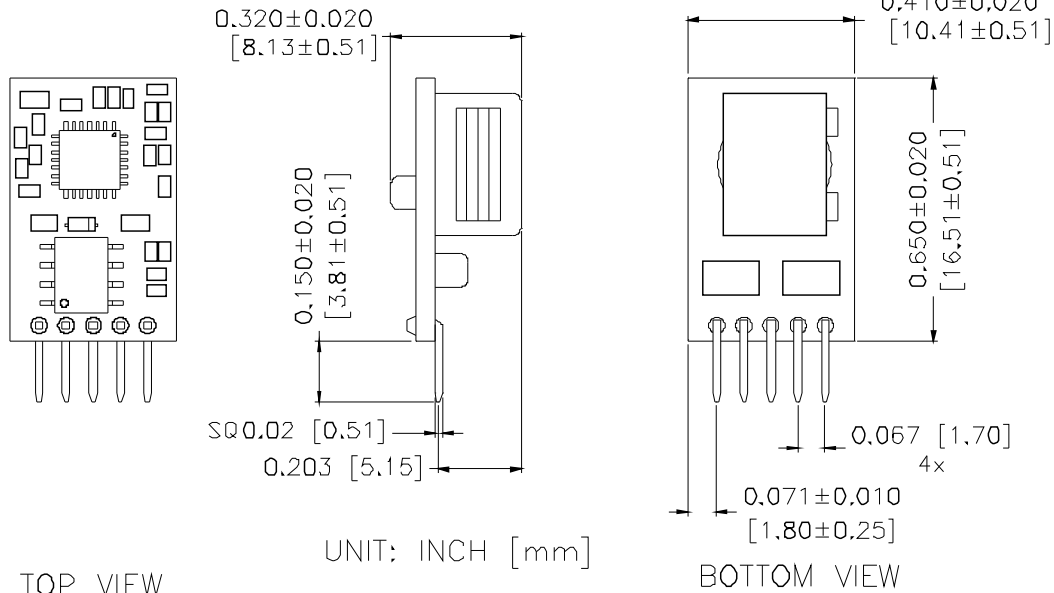

PAD: LENGTH 0.067 [ø1.7] BOTH SIDE
 WIDTH 0.047 [ø1.2] BOTH SIDE
 HOLE: ø0.035 [ø0.89] BOTH SIDE

Pin Connections

Pin	Function
1	ENABLE
2	Vin
3	GND
4	Vout
5	Trim

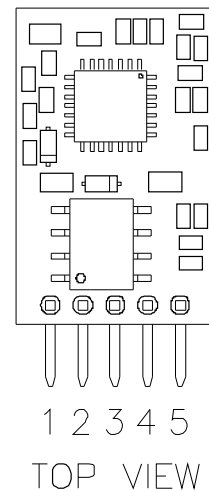

Note: This module is recommended and compatible with Pb-Free Wave Soldering and must be soldered using a peak solder temperature of no more than 260°C for less than 5 seconds.

Note:

- 1) All Pins: Material - Copper Alloy;
 Finish – 3 micro inches minimum Gold over 50 micro inches minimum Nickel plate.
- 2) Undimensioned components are shown for visual reference only.
- 3) All dimensions in inches (mm); Tolerances: x.xx +/-0.02 in[0.5mm] x.xxx +/-0.010 in[0.25mm].

NON-ISOLATED DC/DC CONVERTERS

4.5 Vdc - 13.8 Vdc Input

0.59 Vdc - 5.1 Vdc / 10 A Output



Dec 30, 2015

Bel Power, Inc. , a subsidiary of Bel Fuse, Inc.

Revision History

Date	Revision	Changes Detail	Approval
2008-6-5	A	First release	XF JIANG
2009-4-15	B	Update mechanical drawing	XF JIANG
2015-12-30	C	Add Assembly Note. Update mechanical drawing	XF JIANG

RoHS Compliance

Complies with the European Directive 2011/65/EU, calling for the elimination of lead and other hazardous substances from electronic products.



©2015 Bel Fuse Inc. Specifications subject to change without notice. 123015

CORPORATE

Bel Fuse Inc.
206 Van Vorst Street
Jersey City, NJ 07302
Tel 201-432-0463
Fax 201-432-9542
www.belfuse.com

FAR EAST

Bel Fuse Ltd.
8F/ 8 Luk Hop Street
San Po Kong
Kowloon, Hong Kong
Tel 852-2328-5515
Fax 852-2352-3706
www.belfuse.com

EUROPE

Bel Fuse Europe Ltd.
Preston Technology Management Centre
Marsh Lane, Suite G7, Preston
Lancashire, PR1 8UD, U.K.
Tel 44-1772-556601
Fax 44-1772-888366
www.belfuse.com