

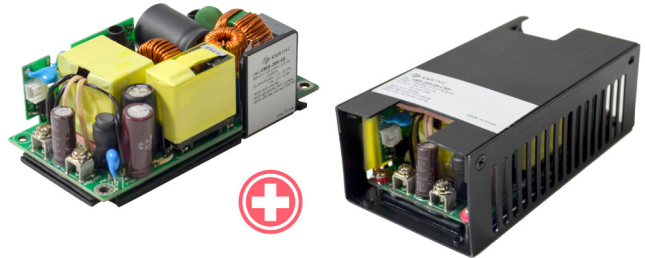

**SERIES:** VMS-200 | **DESCRIPTION:** AC-DC POWER SUPPLY

**FEATURES**

- compact 2 x 4" high power-density design (CNF version is 2.4 x 4.6")
- universal input range
- efficiencies up to 93.5%
- 4th edition medical safeties
- fan output (+12 Vdc)
- over voltage, over current, over temperature and short circuit protections
- covered and open-frame configurations



MODEL	output voltage	output current	output power <sup>1</sup>	ripple and noise <sup>2</sup>	efficiency <sup>3</sup>
	(Vdc)	max (A)	max (W)	max (mVp-p)	typ (%)
VMS-200-12	12	16.67	200	150	92
VMS-200-24	24	8.33	200	240	93.5
VMS-200-48	48	4.17	200	480	93

- Notes:
1. Maximum output power of 200 W with 10 CFM forced air or baseplate cooling, 180 W at 220 Vac with convection cooling.
  2. At full load, nominal input, 20 MHz bandwidth oscilloscope, output terminated with 47 µF aluminum electrolytic and 0.1 µF ceramic capacitors.
  3. At full load, 25°C, 230 Vac input.
  4. All specifications are measured at Ta=25°C, nominal input voltage, and 75% rated output load unless otherwise specified.

**PART NUMBER KEY**

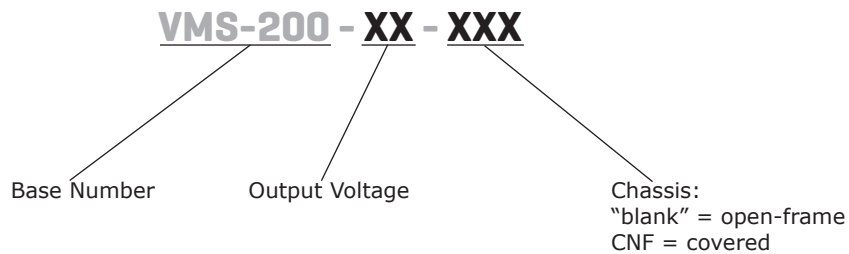

## INPUT

parameter	conditions/description	min	typ	max	units
voltage		90		264	Vac
frequency		47		60	Hz
under voltage shutdown		69		83	Vac
current	at 100 Vac, full load			2.5	A
inrush current	at 240 Vac, 25°C, cold start			100	A
leakage current	at 264 Vac			0.3	mA
leakage current (enclosure/ patient)				0.1	mA
power factor correction	meets EN 61000-3-2				
no load power consumption				0.3	W

## OUTPUT

parameter	conditions/description	min	typ	max	units
output capacitance	at 115/230 Vac, full load 12 Vdc output models 24 Vdc output models 48 Vdc output models			16,400 8,570 1,270	$\mu$ F $\mu$ F $\mu$ F
initial set point accuracy	at 60% load, 25°C		$\pm$ 2		%
line regulation	high line to low line at full load		$\pm$ 0.5		%
load regulation	at 60% $\pm$ 40% load		$\pm$ 1		%
hold-up time	at 115 Vac		10		ms
switching frequency			85		kHz
temperature coefficient			$\pm$ 0.05		%/°C
fan output	open-frame: 12 Vdc / 300 mA covered: 12 Vdc / 500 mA				
LED	indicates when power is on				

## PROTECTIONS

parameter	conditions/description	min	typ	max	units
over voltage protection	recycle ac input to restart 12 Vdc output models 24 Vdc output models 48 Vdc output models		16 31 56		Vdc Vdc Vdc
over current protection	hiccup, auto recovery	130	150	180	%
short circuit protection	hiccup, auto recovery				

## SAFETY & COMPLIANCE

parameter	conditions/description	min	typ	max	units
isolation voltage	input to output for 1 minute input to earth ground for 1 minute output to earth ground for 1 minute			4,000 1,500 1,500	Vac Vac Vac
isolation resistance		100			M $\Omega$
safety approvals	UL/cUL 60601-1 (3.1 edition), IEC 60601-1 (3.1 edition), EN 60601-1 (3.1 edition)				
safety class	Class I & II				
EMI/EMC	EN 60601-1-2 (4th edition)				
conducted disturbance	EN 55011, FCC CFR 47 Part 18, Class B				
radiated disturbance <sup>1</sup>	EN 55011, FCC CFR 47 Part 18, Class B				
harmonic current emissions	IEC 61000-3-2:2014, Class A, Class D				

Notes: 1. Need an external 1 mH choke at input for Class II type to pass EN 55011 Class B.

## SAFETY & COMPLIANCE (CONTINUED)

parameter	conditions/description	min	typ	max	units
voltage fluctuations & flicker	IEC 61000-3-3:2013, Criteria A				
radio-frequency, continuous radiated disturbance	IEC 61000-4-3:2010, Criteria A				
electrical fast transient (EFT)	IEC 61000-4-4:2012, ±0.5 kV, ±1 kV, ±2 kV, Criteria A				
surge	IEC 61000-4-5:2014, L-N: ±0.5 kV, ±1 kV, L-PE, N-PE: ±0.5 kV, ±1 kV, ±2 kV, Criteria A				
conducted disturbances, induced by RF fields	IEC 61000-4-6:2013, Criteria A				
power frequency magnetic field	IEC 61000-4-8:2009, Criteria A				
voltage dips	IEC 61000-4-11:2004, dip: 30% 500 ms, dip: 60% 100 ms, dip >95% 10 ms, Criteria A				
voltage interruptions	IEC 61000-4-11:2004, >95% 5,000 ms, Criteria B				
MTBF	as per MIL-HDBK-217F, at full load, 25°C		279,000		hours
RoHS	2011/65/EU				

## ENVIRONMENTAL

parameter	conditions/description	min	typ	max	units
operating temperature	see derating curves	-20		80	°C
storage temperature		-40		85	°C
operating humidity	non-condensing			93	%
storage humidity	non-condensing			93	%

## DERATING CURVES

VMS-200 Output Power vs. Input Voltage (Natural Convection)

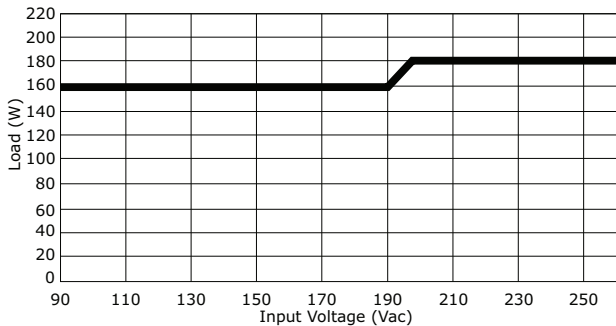

VMS-200-CNF Output Power vs. Input Voltage (Natural Convection)

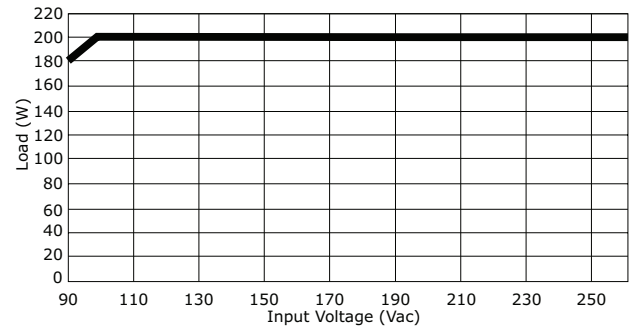

VMS-200 Output Power vs. Ambient Temperature (Natural Convection)

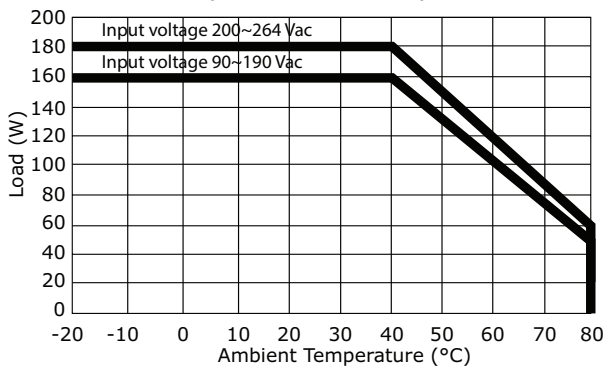

VMS-200-CNF Output Power vs. Ambient Temperature (Natural Convection)

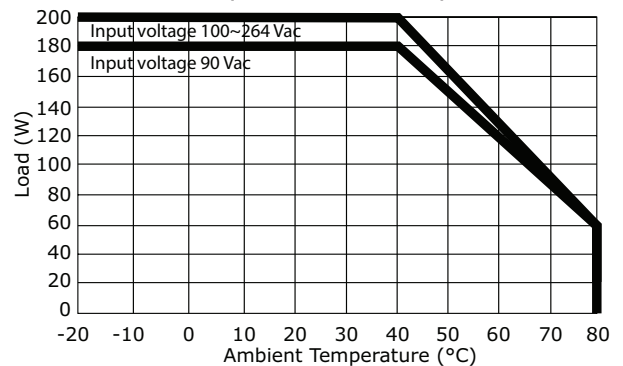

## DERATING CURVES (CONTINUED)

VMS-200 Output Power vs. Ambient Temperature  
(200W with 10 CFM air flow)

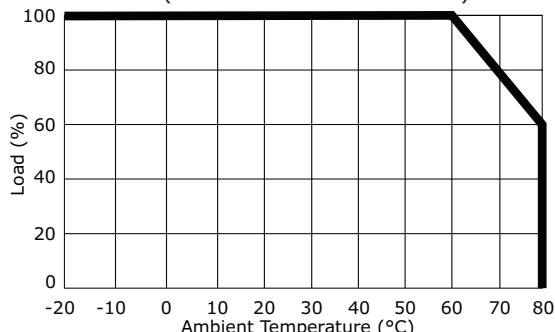

VMS-200-CNF Output Power vs. Ambient Temperature  
(200W with 10 CFM air flow)

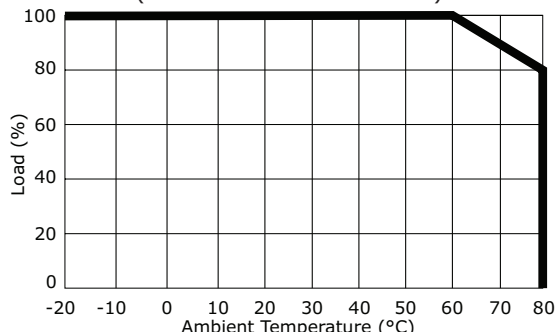

VMS-200 Output Power vs. Ambient Temperature  
(at 115/230 Vac, baseplate cooling, natural convection)

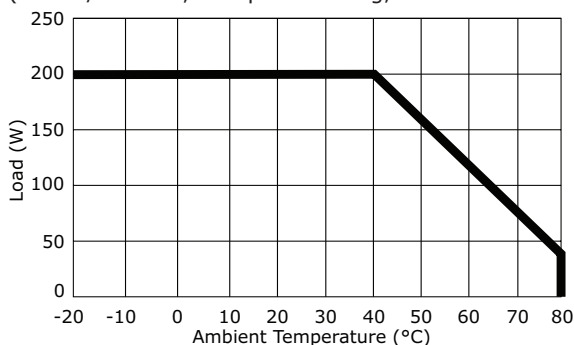

VMS-200-CNF Output Power vs. Ambient Temperature  
(at 115/230 Vac, baseplate cooling, natural convection)

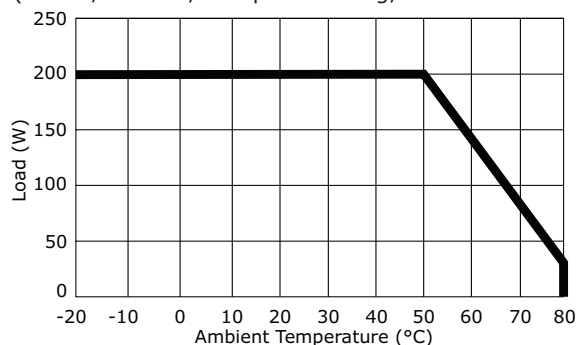

## EFFICIENCY CURVES

12 Vdc Output Efficiency Curve  
(at 25°C)

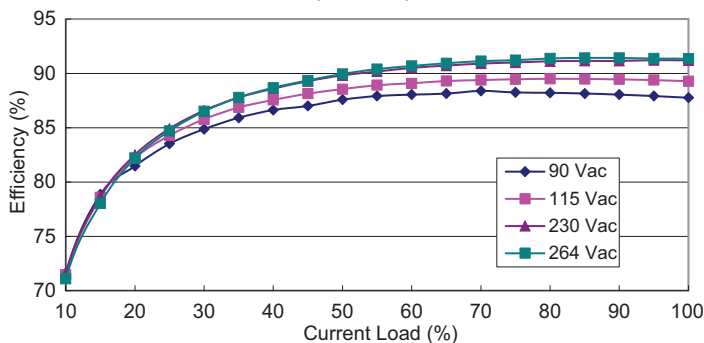

24 Vdc Output Efficiency Curve  
(at 25°C)

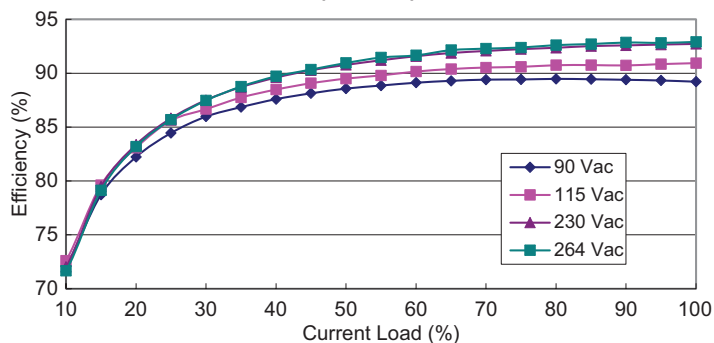

48 Vdc Output Efficiency Curve  
(at 25°C)

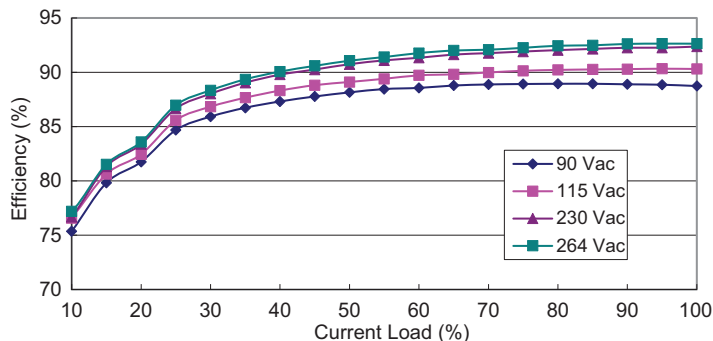

## MECHANICAL

parameter	conditions/description	min	typ	max	units
dimensions	VMS-200 models: 4.000 x 2.000 x 1.480 (101.60 x 50.80 x 37.60 mm) VMS-200-CNF models: 4.606 x 2.441 x 1.575 (117.00 x 62.00 x 40.00 mm)				inch inch
weight	VMS-200 models VMS-200-CNF models		253 314		g g
cooling	external fan or baseplate cooling				
CN1 input connector	CN1 mates with JST housing VHR series, JST SVH-21/41T-P1.1 series crimp terminal or equivalent				
output terminals	+Vo & -Vo terminals are M3 screws				
fan connector	fan mates with JST housing PHR-R5500 series, JST R5503-PT series crimp terminal or equivalent				

## MECHANICAL DRAWING

### Open-frame

units: inch [mm]

tolerance: ±0.020 [±0.50]

CN1	
PIN	Function
1	ACL
2	-
3	ACN

FAN	
PIN	Function
1	FAN V+
2	FAN V-

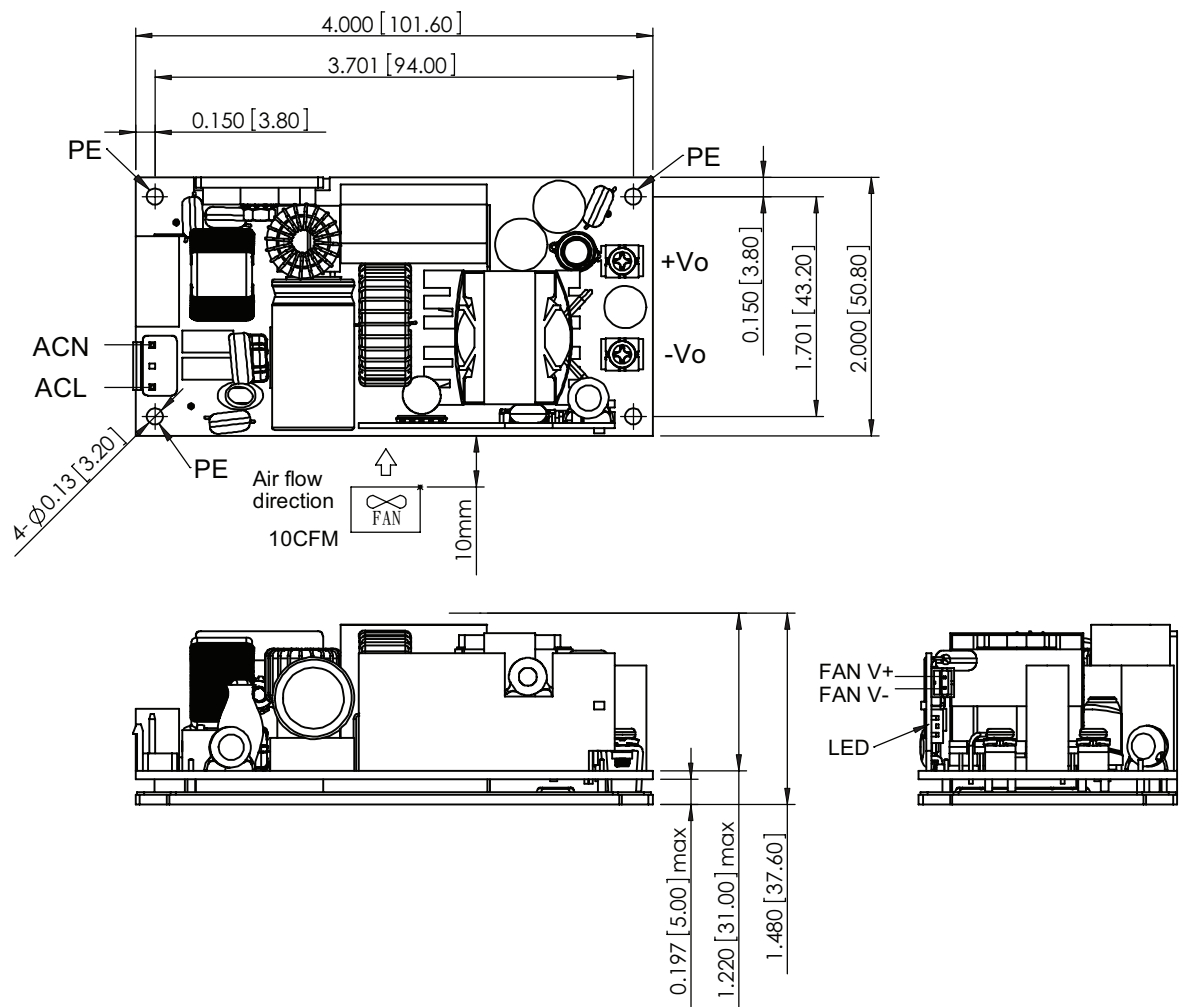

## MECHANICAL DRAWING (CONTINUED)

**Covered**

units: inch [mm]

tolerance: ±0.020 [±0.50]

CN1	
PIN	Function
1	ACL
2	-
3	ACN

FAN	
PIN	Function
1	FAN V+
2	FAN V-

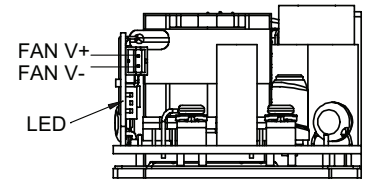
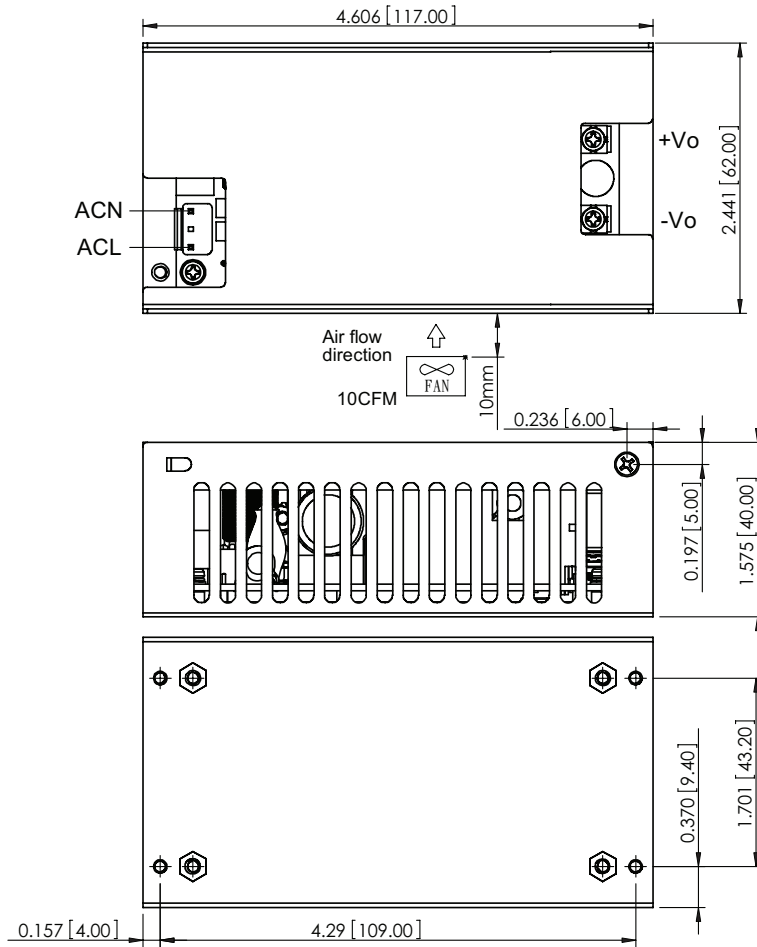

## EMI RECOMMENDATION

To Meet EN 55011 Class B, Class II  
VMS-200

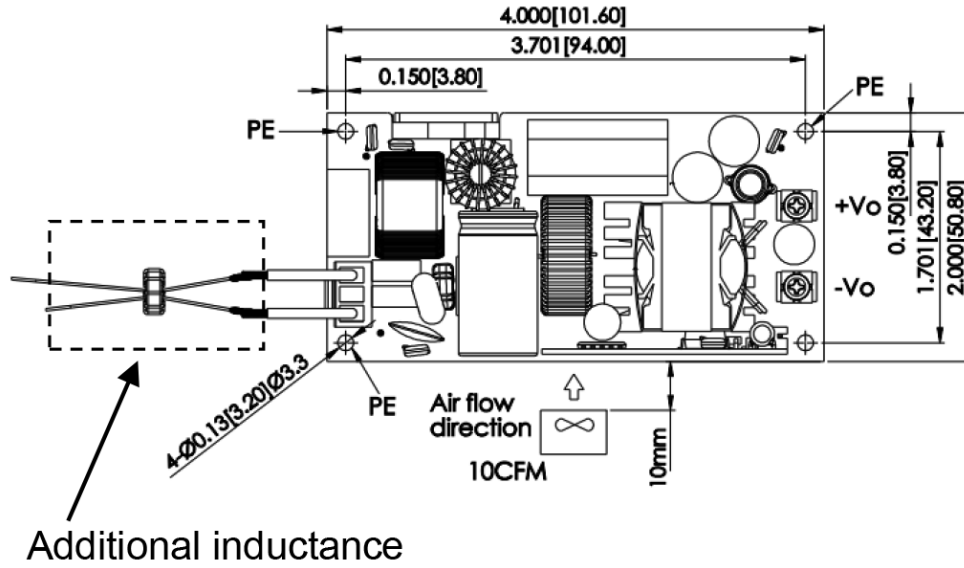

VMS-200-CNF

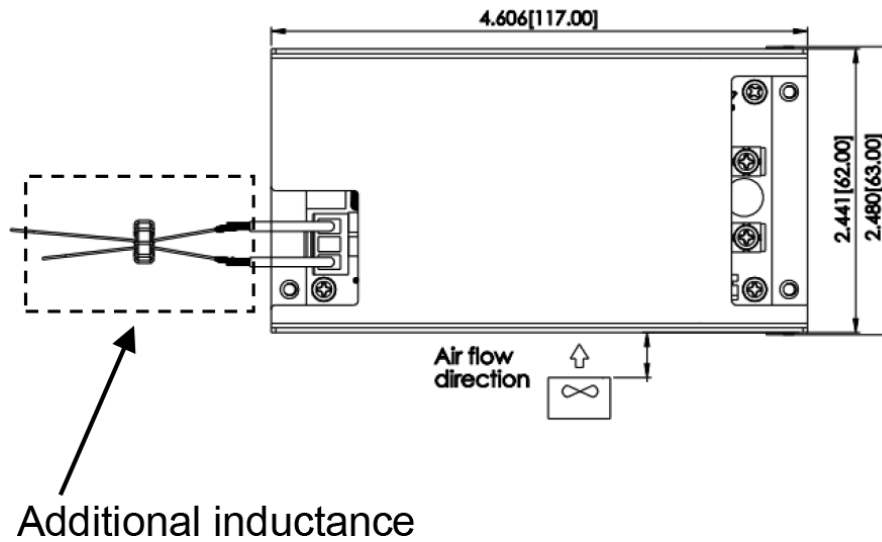

Table 1

Specification	Inductance	Duplex Winding/ Turns	Manufacturers
T16*10*5C R12	1 mH	TEX-E Ø0.65/11T	VAKOS

## INSTALLATION INSRUCTIONS

The VMS-200 series has (4) 3.2 mm diameter mounting holes that can be used in (4) types of installations.

### Type 1

Mounting from top with spacers (VMS-200 models)

Spacer: 5.5 mm diameter max, 5 mm high minimum  
 Screw Size: (4) M3X0.5 (head & washer OD not to exceed 6 mm)  
 Mounting torque: 3 kgf-cm

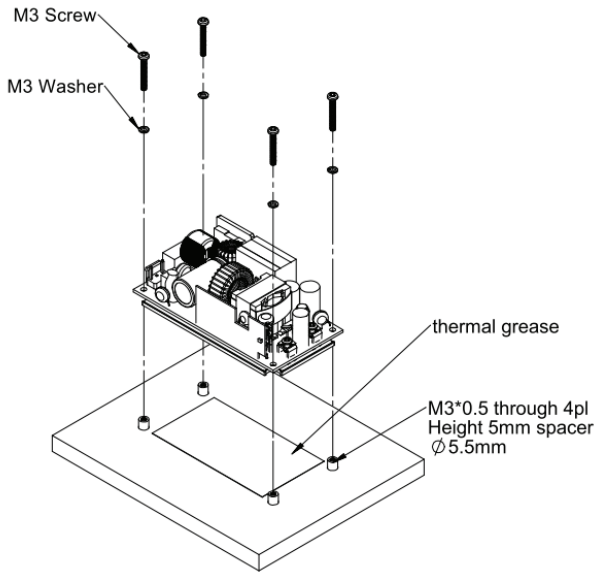

### Type 2

Mounting from bottom (VMS-200-CNF models)

Screw Size: (4) M3X0.5  
 Mounting torque: 3 kgf-cm

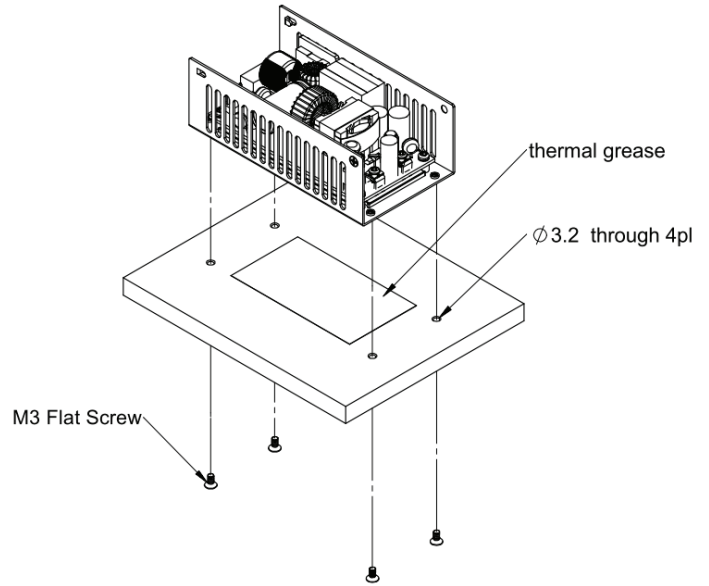

### Type 3 (External Baseplate Cooling)

Mounting from top with spacers (VMS-200 models)

Heat Sink: 280 x 100 x 10 mm  
 Spacer: 5.5 mm diameter max, 5 mm high minimum  
 Screw Size: (4) M3X0.5 (head & washer OD not to exceed 6 mm)  
 Mounting torque: 3 kgf-cm

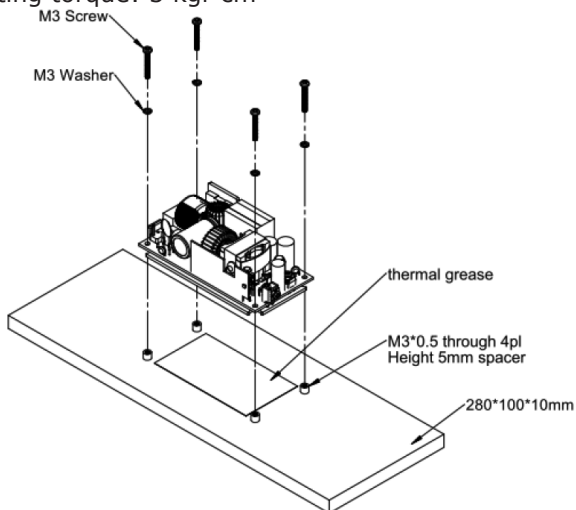

### Type 4 (External Baseplate Cooling)

Mounting from bottom (VMS-200-CNF models)

Heat Sink: 280 x 100 x 10 mm  
 Screw Size: (4) M3X0.5  
 Mounting torque: 3 kgf-cm

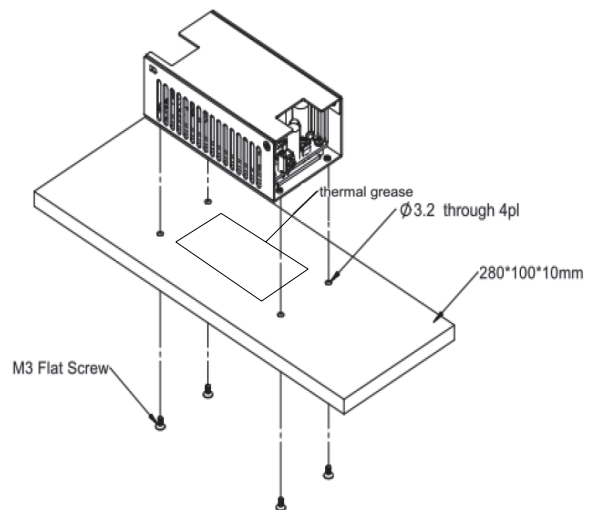

## INSTALLATION INSRUCTIONS (CONTINUED)

### Output Terminals

Mate with round or Y terminals

Terminal Size: (2) M3

Torque: 3 kgf-cm

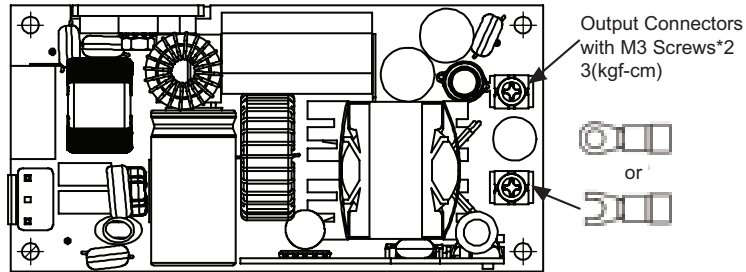

### Mounting Clearance

Allow at least 4 mm side clearance and 5 mm height clearance. If clearances aren't met, the isolation and withstand specifications may not be met.

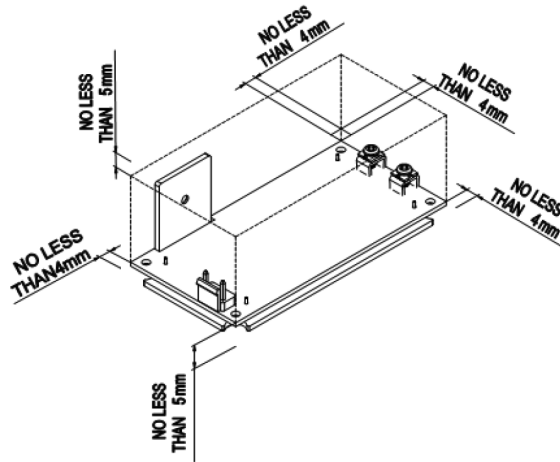

### Protective Earth

PE should be connected to the earth (ground) terminal of the apparatus otherwise conducted noise and output noise will increase.

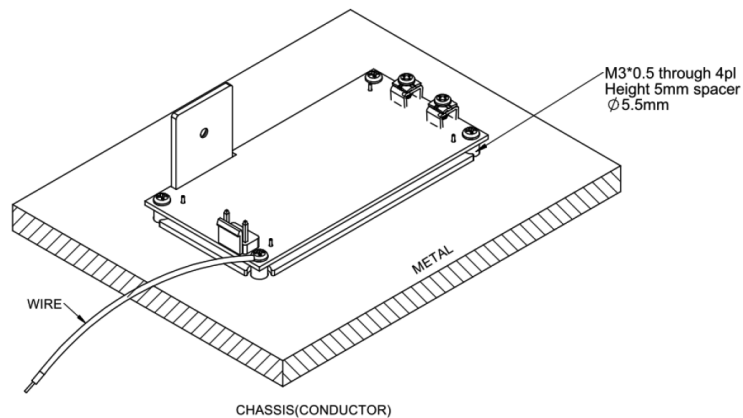

## REVISION HISTORY

---

<b>rev.</b>	<b>description</b>	<b>date</b>
1.0	initial release	12/12/2017

The revision history provided is for informational purposes only and is believed to be accurate.



**CUI INC**<sup>®</sup>

**Headquarters**  
20050 SW 112th Ave.  
Tualatin, OR 97062  
**800.275.4899**

Fax 503.612.2383  
**cui.com**  
techsupport@cui.com

CUI offers a two (2) year limited warranty. Complete warranty information is listed on our website.

CUI reserves the right to make changes to the product at any time without notice. Information provided by CUI is believed to be accurate and reliable. However, no responsibility is assumed by CUI for its use, nor for any infringements of patents or other rights of third parties which may result from its use.

CUI products are not authorized or warranted for use as critical components in equipment that requires an extremely high level of reliability. A critical component is any component of a life support device or system whose failure to perform can be reasonably expected to cause the failure of the life support device or system, or to affect its safety or effectiveness.