



Data Sheet

VI-RAM™/VE-RAM (RoHS Compliant)



Ripple Attenuator Modules



Features

- RoHS compliant (VE versions)
- Reduces output ripple to <3 mV pp
- Compatible with any VI-200/VI-J00-based product: 5 to 50 Vdc output
- Full attenuation up to 20 A
- No adjustments required
- 93 – 99% efficiency
- Converter sense, trim, overvoltage and overcurrent retained
- Size: 2.28" x 2.4" x 0.5" (57,9 x 61,0 x 12,7 mm)
- CE Marked

Product Highlights

Ripple attenuator modules may be connected to VI-200 or VI-J00 converters, FlatPACs, ComPACs or MegaModules, with output voltages from 5 – 50 V, to limit output noise to less than 3 mV peak-to-peak at loads up to 20 A. Combining active and passive filtering, the VI-RAM attenuates both low frequency input power source fundamental and harmonics, as well as high frequency switching components in the frequency range of DC to 20 MHz, while exhibiting efficiencies of 93-99%. No adjustments are required, and remote sense and output voltage trim features are retained.

A member of Vicor's high-power density, high performance, component-level power building blocks, the VI-RAM offers the power systems architect a single, flexible, component-level solution to almost any "clean power" problem. At the same time, the VI-RAM eliminates the space, efficiency, and weight penalties associated with linear power sources, and the stability, efficiency, and adjustment penalties associated with external "add on" filters for conventional switchers.

VI-RAM Specifications

(typical at T_{BP} = 25°C, nominal line, 75% load unless otherwise specified)

Parameter	Min.	Typ.	Max.	Remarks
Output Noise & Ripple				
VI-200			3 mV pp	From 10% of full rated output current of the source converter to full load
VI-J00			10 mV pp	
Input Voltage Range	5 Vdc		50 Vdc	
Output Voltage Deviation		0.5%		From the output voltage of the VI-200 source to which the VI-RAM will be connected
Full Load Current			10 A 20 A	E1, C1, I1 or M1 E2, C2, I2 or M2
Overload Current			30 A	At max. operating baseplate temperature
DC Voltage Drop	0.34 0.34 0.34		0.41 0.44 0.75	Up to 10 A Up to 20 A Up to 30 A (overload)
	Dissipation = (DC voltage drop) x (Load current + 15 mA)			
Isolation		500V _{RMS}		Input/Output to baseplate
Size	2.28" x 2.4" x 0.5" (57,9 x 61,0 x 12,7)			SlimMod and FinMod packages available
Weight				
E,C-Grade		3.0(85)		Ounces(Grams)
I,M-Grade	3.6(102)	3.7(105)	3.8(107)	

Electrical Considerations

Transient Response and Dynamic Range: Full rated noise attenuation will be maintained at the VI-RAM output for step load changes up to 10% of the rated output current of the source converter, with the VI-RAM exhibiting an underdamped output excursion of less than 10 mV pp. Some degradation in noise attenuation during the transient response period following the step may be exhibited for larger load changes. Adding output capacitance to the VI-RAM will improve the rejection over a larger dynamic range.

Sense Connection: Sense -In and Sense -Out connections are provided on the VI-RAM. Sense -In connections must be connected to the corresponding sense connections on the Vicor converter. Sense -Out pins on the VI-RAM must be connected between the VI-RAM power-output pins and the point of load.

Output Load Characteristics: When used in combination with Vicor DC-DC converters, and with sense leads connected, the VI-RAM will be stable for any non-inductive load.

DC Voltage Drop: Below full load, the input to output DC Voltage Drop is controlled to be an essentially constant voltage which appears between the -IN and -OUT terminals. In overload the DC voltage drop will rise as current increases. A few tens of millivolts appears between the +IN and +OUT terminals. Care should be taken not to connect IN and OUT terminals (i.e. through scope probe returns, grounds, etc.), as attenuation will be adversely affected.

Product Grade Specifications

Parameter (Up to 10 A) (Up to 20 A)	VI-RAM-E1 VI-RAM-E2	VI-RAM-C1 VI-RAM-C2	VI-RAM-I1 VI-RAM-I2	VI-RAM-M1 VI-RAM-M2
Storage Temp.	-20°C to +105°C	-40°C to +105°C	-55°C to +105°C	-65°C to +105°C
Operating Temp. (Baseplate)	-10°C to +100°	-25°C to +100°C	-40°C to +100°C	-55°C to +100°C

Comparison of Input to Output Ripple (typical)

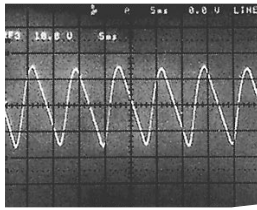

Input to the converter 10 V/cm

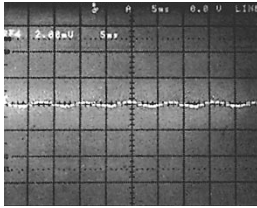

Output from the RAM 20 mV/cm

Attenuation vs. Frequency (typical)

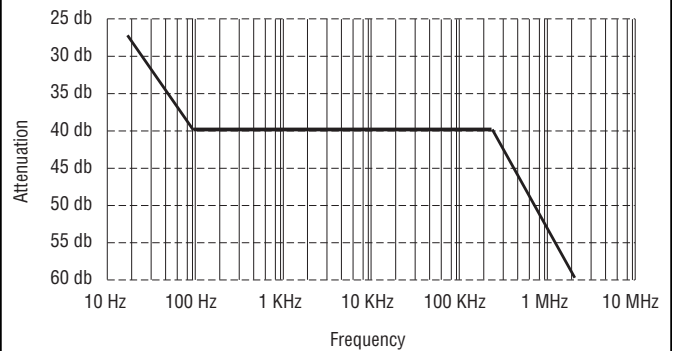

Recommended Connection Diagram

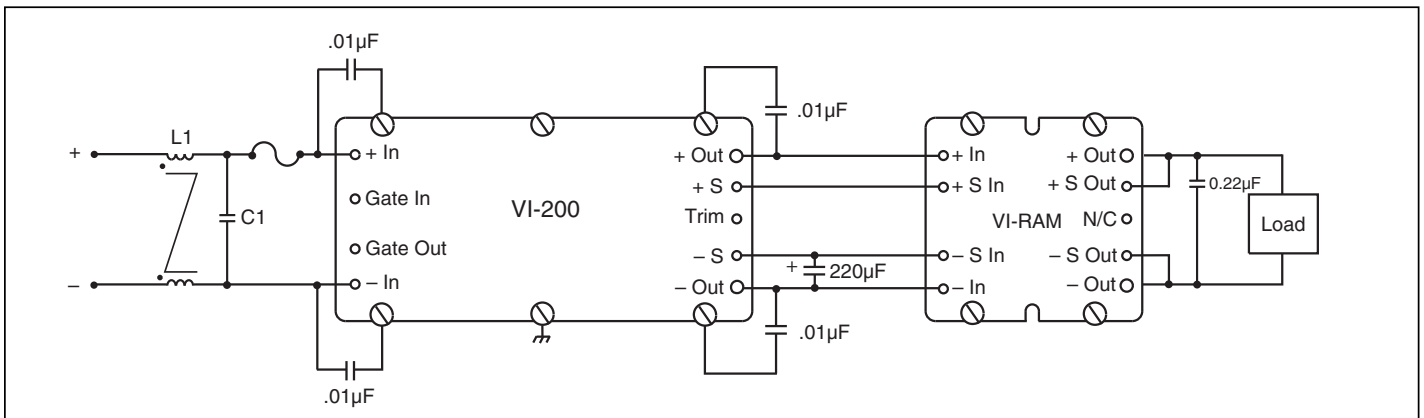

For important application information please refer to the [Design Guide and Applications Manual](#) for VI-200 and VI-J00 Family.

MECHANICAL DRAWING

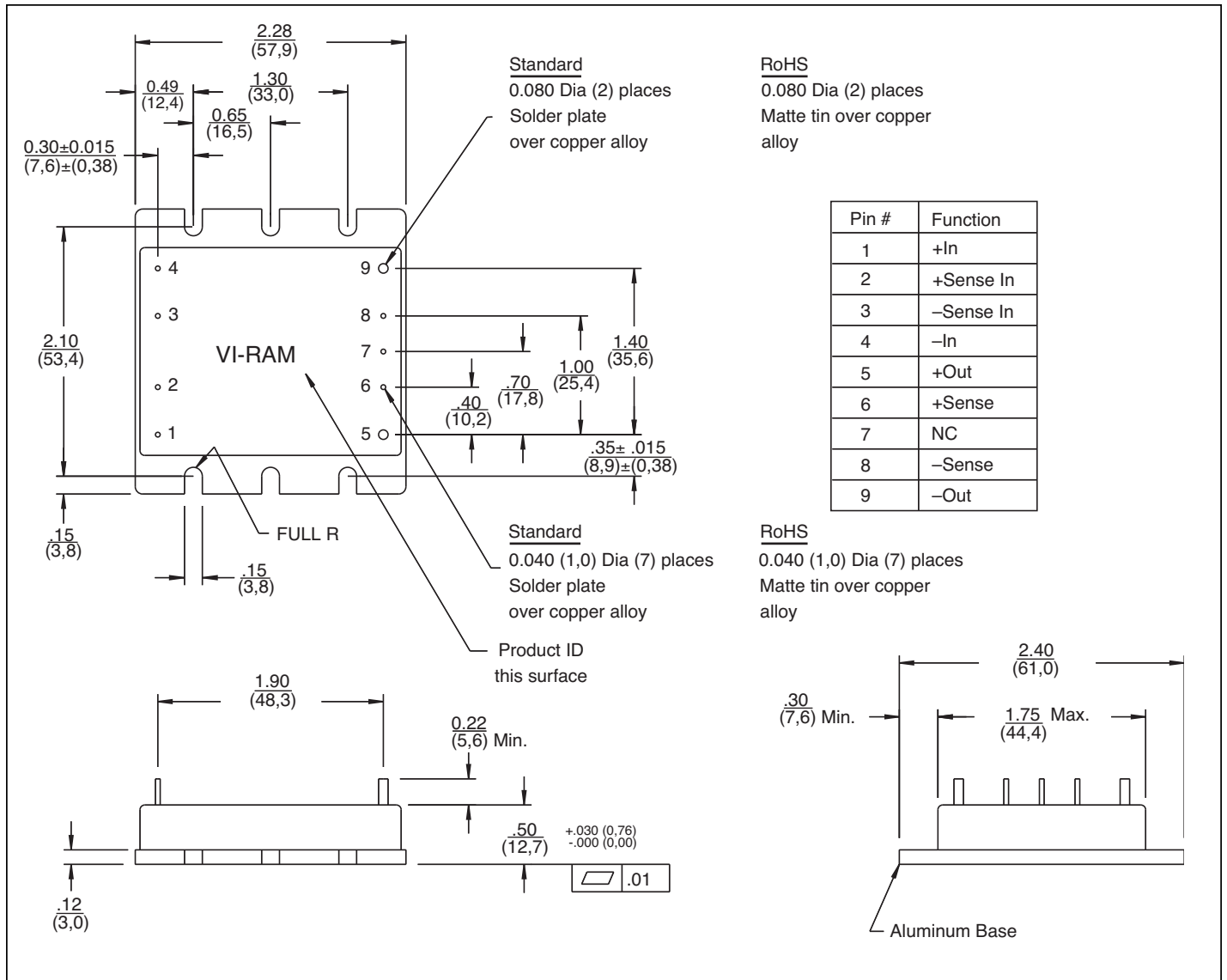

Warranty

Vicor products are guaranteed for two years from date of shipment against defects in material or workmanship when in normal use and service. This warranty does not extend to products subjected to misuse, accident, or improper application or maintenance. Vicor shall not be liable for collateral or consequential damage. This warranty is extended to the original purchaser only.

EXCEPT FOR THE FOREGOING EXPRESS WARRANTY, VICOR MAKES NO WARRANTY, EXPRESS OR IMPLIED, INCLUDING, BUT NOT LIMITED TO, THE WARRANTY OF MERCHANTABILITY OR FITNESS FOR A PARTICULAR PURPOSE.

Vicor will repair or replace defective products in accordance with its own best judgement. For service under this warranty, the buyer must contact Vicor to obtain a Return Material Authorization (RMA) number and shipping instructions. Products returned without prior authorization will be returned to the buyer. The buyer will pay all charges incurred in returning the product to the factory. Vicor will pay all reshipment charges if the product was defective within the terms of this warranty.

Information published by Vicor has been carefully checked and is believed to be accurate; however, no responsibility is assumed for inaccuracies. Vicor reserves the right to make changes to any products without further notice to improve reliability, function, or design. Vicor does not assume any liability arising out of the application or use of any product or circuit; neither does it convey any license under its patent rights nor the rights of others. Vicor general policy does not recommend the use of its components in life support applications wherein a failure or malfunction may directly threaten life or injury. Per Vicor Terms and Conditions of Sale, the user of Vicor components in life support applications assumes all risks of such use and indemnifies Vicor against all damages.

Vicor's comprehensive line of power solutions includes high density AC-DC and DC-DC modules and accessory components, fully configurable AC-DC and DC-DC power supplies, and complete custom power systems.

Information furnished by Vicor is believed to be accurate and reliable. However, no responsibility is assumed by Vicor for its use. Vicor components are not designed to be used in applications, such as life support systems, wherein a failure or malfunction could result in injury or death. All sales are subject to Vicor's Terms and Conditions of Sale, which are available upon request.

Specifications are subject to change without notice.

Intellectual Property Notice

Vicor and its subsidiaries own Intellectual Property (including issued U.S. and Foreign Patents and pending patent applications) relating to the products described in this data sheet. Interested parties should contact Vicor's Intellectual Property Department.

Vicor Corporation
25 Frontage Road
Andover, MA, USA 01810
Tel: 800-735-6200
Fax: 978-475-6715

email

Customer Service: custserv@vicorpower.com
Technical Support: apps@vicorpower.com