

SERIES: VHK50W-DIN | **DESCRIPTION:** DC-DC CONVERTER

FEATURES

- up to 50 W isolated output
- rugged metal enclosure with integrated heat sink
- 4:1 input range (9~36 Vdc, 18~75 Vdc)
- single output from 3.3~48 Vdc
- 1,500 Vdc isolation
- over current, over temperature, over voltage, and short circuit protections
- remote on/off
- efficiency up to 83%
- comes with DIN-rail mount



MODEL	input voltage	output voltage	output current	output power	ripple and noise ¹	efficiency
	range (Vdc)	(Vdc)	max (A)	max (W)	max (mVp-p)	typ (%)
VHK50W-Q24-S3R3-DIN	9 ~ 36	3.3	10	33	100	75
VHK50W-Q24-S5-DIN	9 ~ 36	5	10	50	100	79
VHK50W-Q24-S12-DIN	9 ~ 36	12	4.16	50	150	82
VHK50W-Q24-S15-DIN	9 ~ 36	15	3.33	50	150	82
VHK50W-Q24-S24-DIN	9 ~ 36	24	2.08	50	240	82
VHK50W-Q24-S28-DIN	9 ~ 36	28	1.78	50	280	82
VHK50W-Q24-S48-DIN	9 ~ 36	48	1.04	50	480	82
VHK50W-Q48-S3R3-DIN	18 ~ 75	3.3	10	33	100	76
VHK50W-Q48-S5-DIN	18 ~ 75	5	10	50	100	80
VHK50W-Q48-S12-DIN	18 ~ 75	12	4.16	50	150	83
VHK50W-Q48-S15-DIN	18 ~ 75	15	3.33	50	150	83
VHK50W-Q48-S24-DIN	18 ~ 75	24	2.08	50	240	83
VHK50W-Q48-S28-DIN	18 ~ 75	28	1.78	50	280	83
VHK50W-Q48-S48-DIN	18 ~ 75	48	1.04	50	480	83

Note: 1. Ripple and noise are measured at full load, 20 MHz BW with 10 μ F tantalum capacitor and 1 μ F ceramic capacitor across output. The 48 Vdc output models only require the 1 μ F ceramic capacitor across the output.

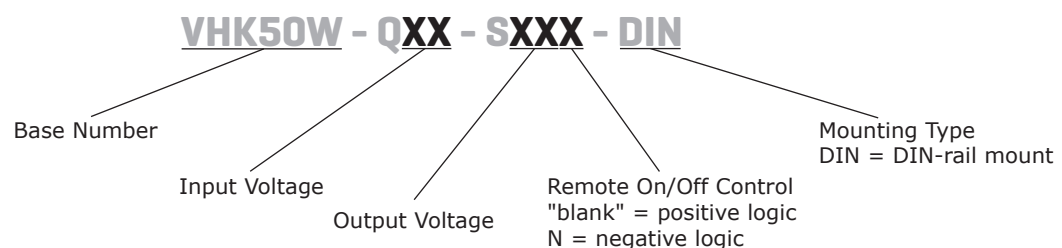
PART NUMBER KEY

INPUT

parameter	conditions/description	min	typ	max	units
operating input voltage	24 Vdc input models	9	24	36	Vdc
	48 Vdc input models	18	48	75	Vdc
under voltage shutdown	24 Vdc input		8.8		Vdc
	power up power down		8		Vdc
	48 Vdc input		17		Vdc
	power up power down		16		Vdc
CTRL ¹	positive logic	models ON (open circuit)			
		models OFF (0~0.8 Vdc)			
	negative logic	models ON (0~0.8 Vdc)			
		models OFF (open circuit)			
filter	pi filter				
input fuse	15A time delay fuse for 24 Vin models, 8A time delay fuse for 48 Vin models				

Note: 1. Open collector refer to -Vin

OUTPUT

parameter	conditions/description	min	typ	max	units
maximum capacitive load	3.3 and 5 V output models			10,000	μF
	12 V output models			4,160	μF
	15 V output models			3,330	μF
	24 V output models			2,080	μF
	28 V output models			1,780	μF
	48 V output models	47		1,040	μF
line regulation ²	measured from high line to low line			±0.2	%
load regulation ²	measured from full load to zero load			±0.2	%
voltage accuracy ²				±1	%
adjustability				±10	%
switching frequency				300	kHz
transient response	25% step load change			500	μs
temperature coefficient				±0.03	%/°C

Note: 2. A 47 μF aluminum capacitor is required on the output for 48 Vdc output models.

PROTECTIONS

parameter	conditions/description	min	typ	max	units
short circuit protection	continuous				
over current protection	% nominal output current	110		160	%
over voltage protection		115		140	%
over temperature protection	shutdown		100		°C
	restart threshold		70		°C

SAFETY AND COMPLIANCE

parameter	conditions/description	min	typ	max	units
isolation voltage	for 1 min: input/output; input/case; output/case	1,500			Vdc
isolation resistance		10			MΩ
RoHS	2011/65/EU (CE)				

ENVIRONMENTAL

parameter	conditions/description	min	typ	max	units
operating temperature	see derating curve	-40		85	°C
storage temperature		-55		105	°C

MECHANICAL

parameter	conditions/description	min	typ	max	units
dimensions	4.23 x 4.01 x 2.07 (107.5 x 101.8 x 52.6 mm)				inch
case material	steel and aluminum extrusion				
weight			651		g

MECHANICAL DRAWING

units: inch[mm]

tolerance: X.XX = ±0.02[±0.5]
X.XXX = ±0.010[±0.25]

wire range: 22~12 AWG
screw size: #6-32
mounts to TS35 rails

PIN CONNECTIONS	
PIN	FUNCTION
1	+Vin
2	-Vin
3	REM
4	CASE
5	+Vo
6	+S
7	TRIM
8	-S
9	-Vo

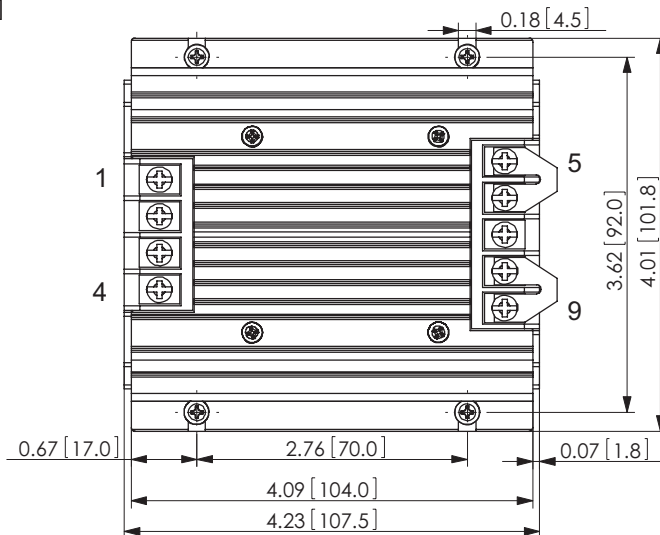

Top View

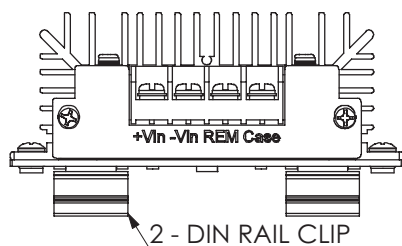

Front View

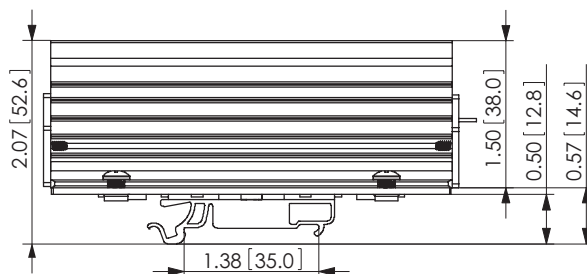

Side View

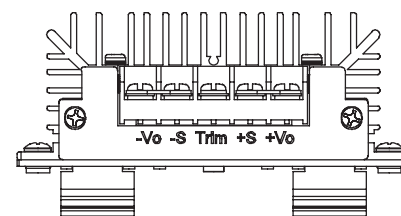

Back View

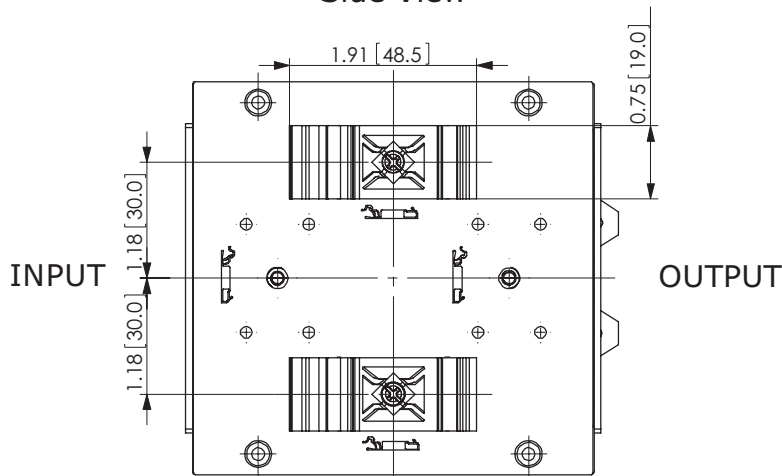

Bottom View

DERATING CURVES

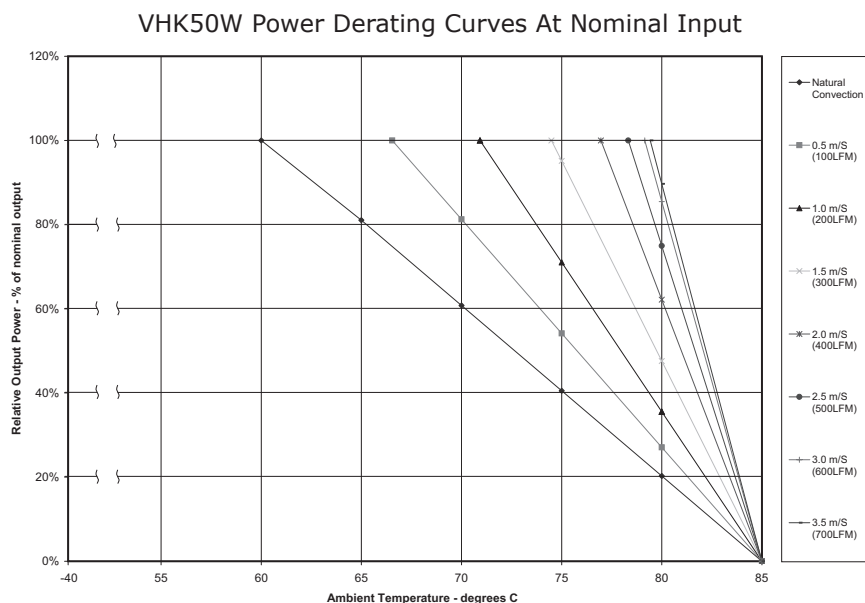

TEST CONFIGURATION

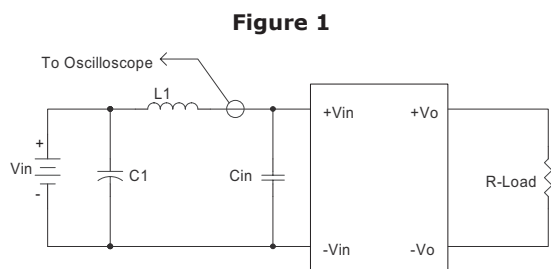

Table 1

External components	
L1	12μH
C1	220μF, ESR < 0.1Ω at 100 KHz
Cin	100μF, ESR < 0.1Ω at 100 KHz

Note: Input reflected-ripple current is measured with an inductor L1 and Capacitor C1 to simulate source impedance.

EMC RECOMMENDED CIRCUITS

EN55022 CLASS A

Figure 2
Recommended Circuit for EN55022 Class A
 (for all 3.3, 5, 12, 15, 24, & 28 Vdc output models)

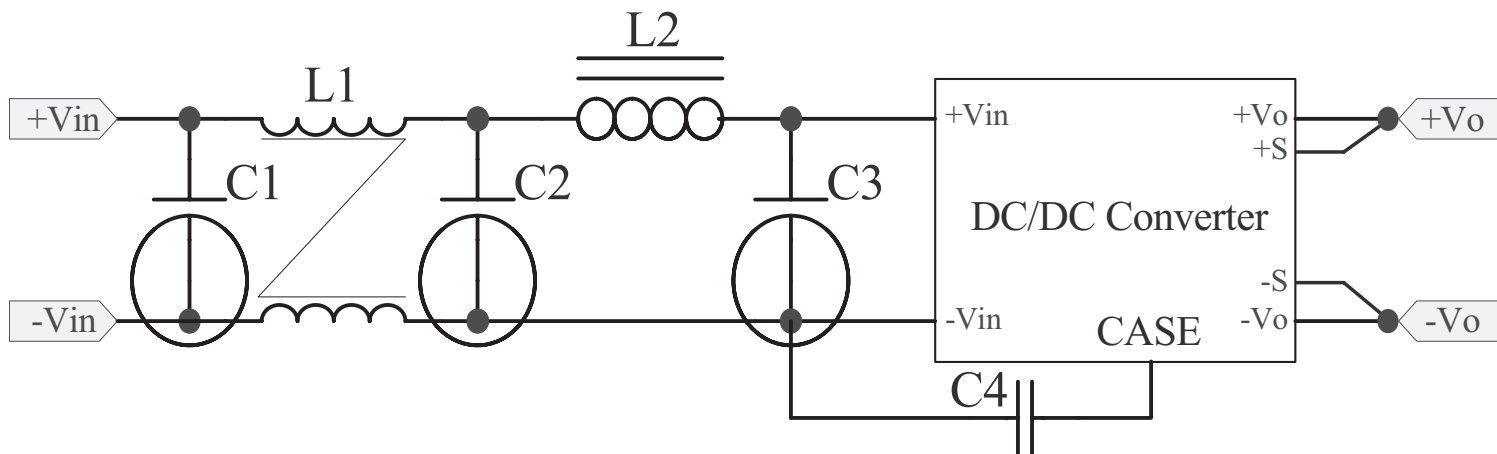

EMC RECOMMENDED CIRCUITS (CONTINUED)

EN55022 CLASS A

Figure 3
Recommended Circuit for EN55022 Class A
 (for all 48 Vdc output models)

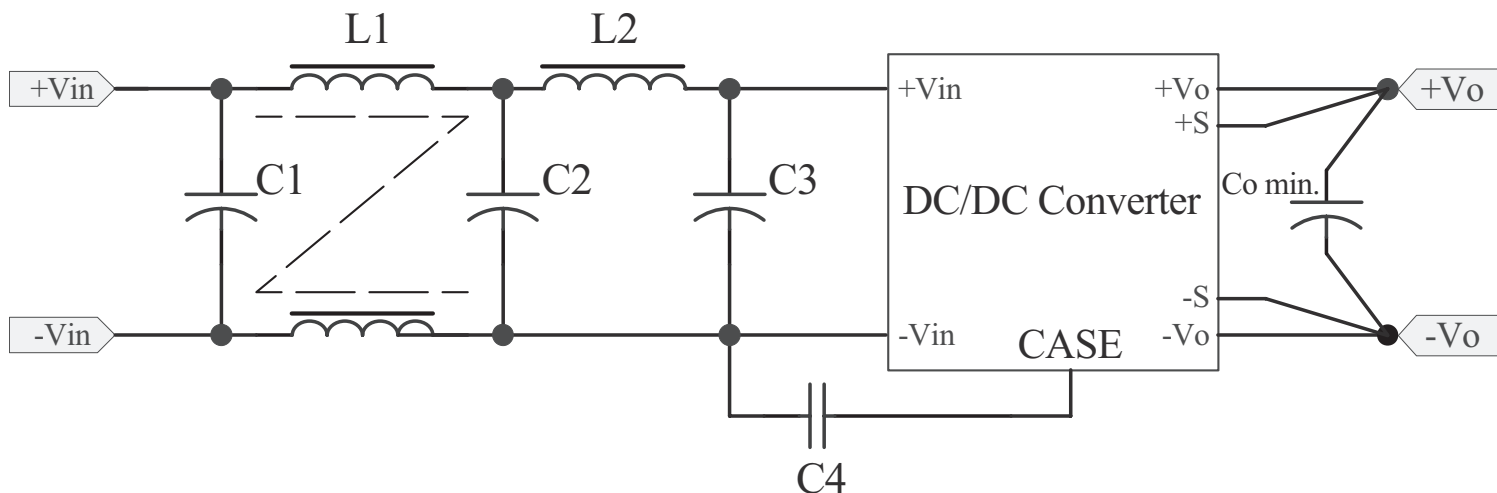

Table 2
Class A Recommended Components

Model	C1 ¹	C2 ²	C3 ²	C4 ¹	L1	L2	Co min.
VHK50W-Q24-S3R3	NC	100 µF/50 V	100 µF/50 V	2200 pF/2 kV	Short	3.5 µH	NC
VHK50W-Q24-S5	NC	100 µF/50 V	100 µF/50 V	2200 pF/2 kV	Short	3.5 µH	NC
VHK50W-Q24-S12	NC	100 µF/50 V	100 µF/50 V	2200 pF/2 kV	Short	3.5 µH	NC
VHK50W-Q24-S15	NC	100 µF/50 V	100 µF/50 V	2200 pF/2 kV	Short	3.5 µH	NC
VHK50W-Q24-S24	10 µF/50 V	100 µF/50 V	100 µF/50 V	NC	1.5 mH	3.4 µH	NC
VHK50W-Q24-S28	NC	100 µF/50 V	100 µF/50 V	2200 pF/2 kV	Short	3.4 µH	NC
VHK50W-Q24-S48	NC	100 µF/50 V	100 µF/50 V	NC	Short	3.5 µH	47 µF
VHK50W-Q48-S3R3	NC	47 µF/100 V	47 µF/100 V	2200 pF/2 kV	Short	3.4 µH	NC
VHK50W-Q48-S5	NC	47 µF/100 V	47 µF/100 V	2200 pF/2 kV	Short	3.4 µH	NC
VHK50W-Q48-S12	NC	47 µF/100 V	47 µF/100 V	2200 pF/2 kV	Short	3.4 µH	NC
VHK50W-Q48-S15	NC	47 µF/100 V	47 µF/100 V	2200 pF/2 kV	Short	3.4 µH	NC
VHK50W-Q48-S24	NC	47 µF/100 V	47 µF/100 V	2200 pF/2 kV	Short	3.4 µH	NC
VHK50W-Q48-S28	NC	100 µF/100 V	100 µF/100 V	2200 pF/2 kV	Short	3.4 µH	NC
VHK50W-Q48-S48	NC	47 µF/100 V	47 µF/100 V	2200 pF/2 kV	Short	3.5 µH	47 µF

Note: 1. Ceramic capacitors
 2. Aluminum capacitors

EMC RECOMMENDED CIRCUITS (CONTINUED)

EN55022 CLASS B

Figure 4
Recommended Circuit for EN55022 Class B
 (for all 3.3, 5, 12, 15, & 24 Vdc output models)

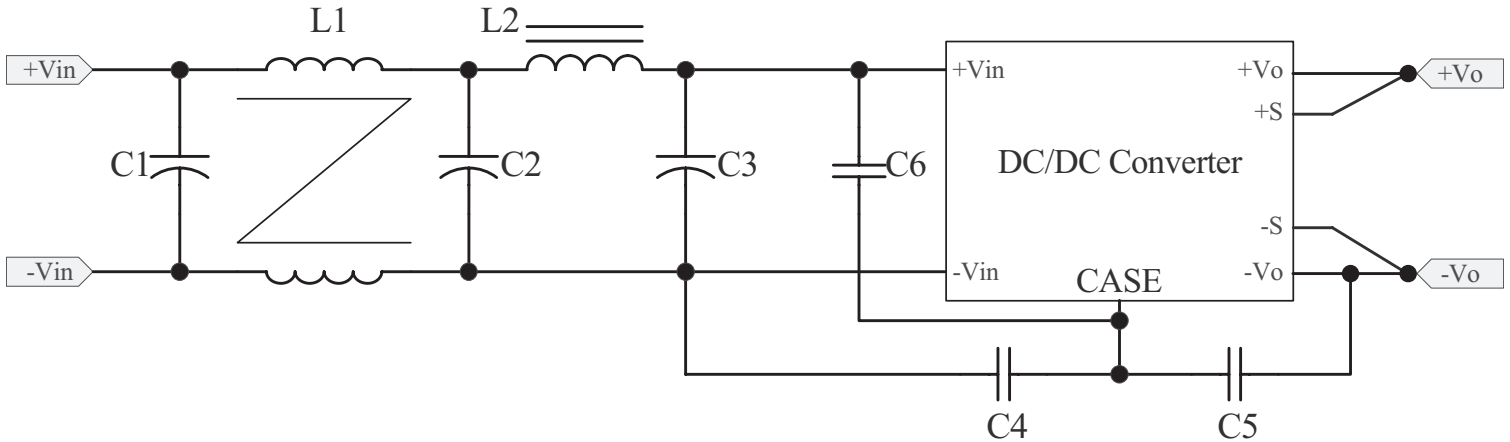

Figure 5
Recommended Circuit for EN55022 Class B
 (for all 28 Vdc output models)

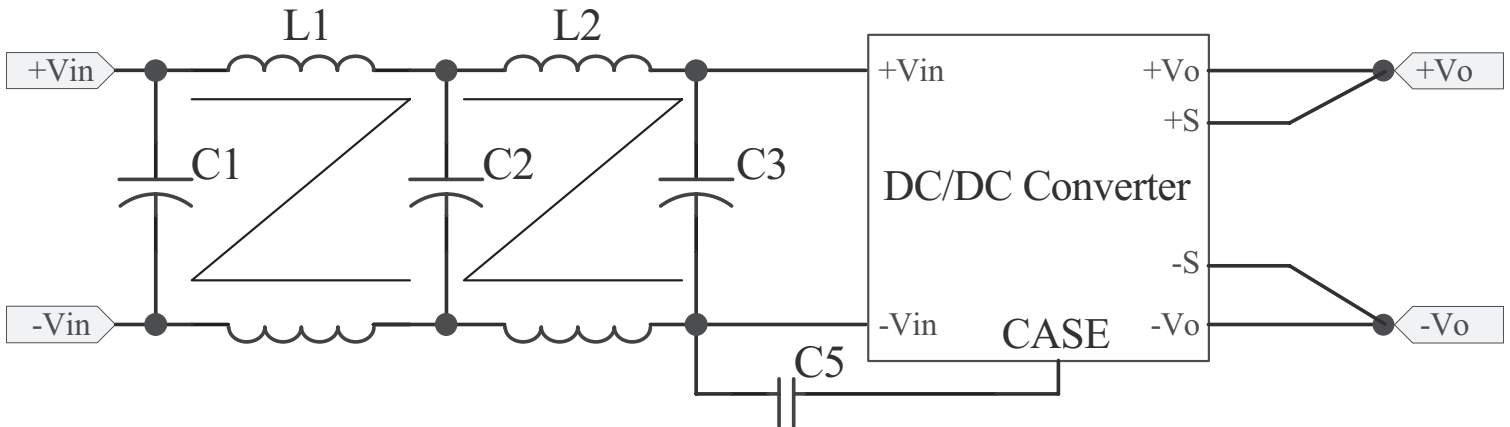
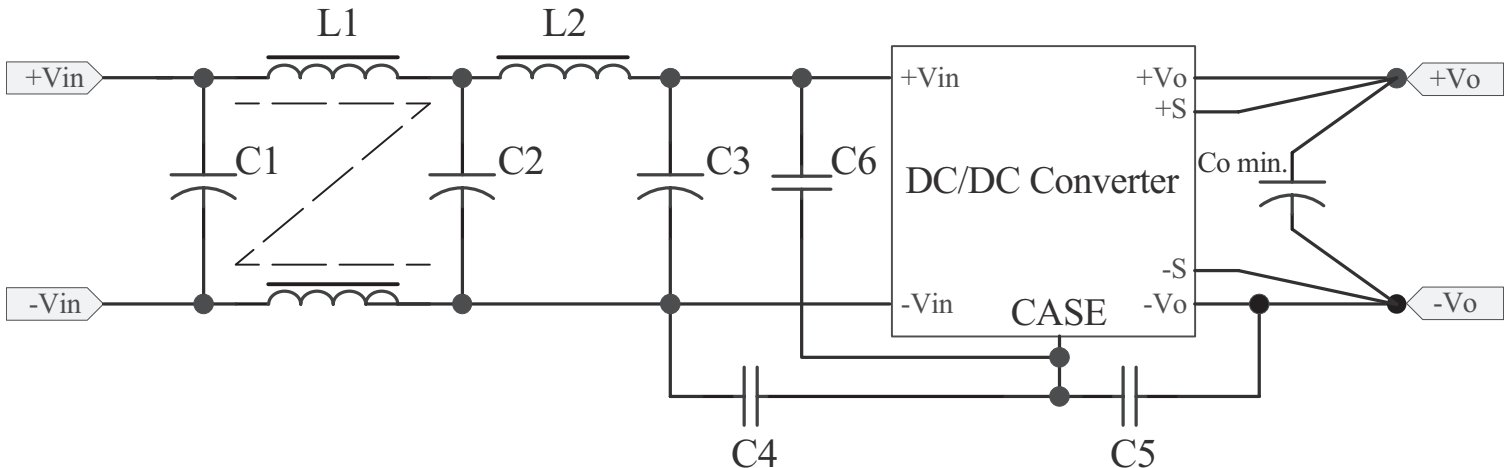

Figure 6
Recommended Circuit for EN55022 Class B
 (for all 48 Vdc output models)



EMC RECOMMENDED CIRCUITS (CONTINUED)**EN55022 CLASS B****Table 3
Class B Recommended Components**

Model	C1 ²	C2 ²	C3 ²	C4 ¹	C5 ¹	C6 ¹	L1	L2	Co min.
VHK50W-Q24-S3R3	100 µF/50 V	100 µF/50 V	100 µF/50 V	3300 pF/2 kV	NC	NC	0.65 mH	1.5 µH	NC
VHK50W-Q24-S5	100 µF/50 V	100 µF/50 V	100 µF/50 V	2200 pF/2 kV	NC	NC	0.65 mH	1.5 µH	NC
VHK50W-Q24-S12	100 µF/50 V	100 µF/50 V	100 µF/50 V	3300 pF/2 kV	NC	NC	0.65 mH	1.5 µH	NC
VHK50W-Q24-S15	100 µF/50 V	100 µF/50 V	100 µF/50 V	2200 pF/2 kV	NC	NC	0.65 mH	1.5 µH	NC
VHK50W-Q24-S24	10 µF/50 V ¹	100 µF/50 V	100 µF/50 V	2200 pF/2 kV	3300 pF/2 kV	1000 pF/2 kV	1.5 mH	3.4 µH	NC
VHK50W-Q24-S28	100 µF/50 V	100 µF/50 V	NC	NC	1000 pF/2 kV	NC	0.12 mH	0.34 mH	NC
VHK50W-Q24-S48	10 µF/50 V ¹	100 µF/50 V	100 µF/50 V	4700 pF/2 kV	2200 pF/2 kV	1000 pF/2 kV	1.5 mH	3.4 µH	47 µF
VHK50W-Q48-S3R3	47 µF/100 V	47 µF/100 V	47 µF/100 V	3300 pF/2 kV	3300 pF/2 kV	1000 pF/2 kV	1.5 mH	3.4 µH	NC
VHK50W-Q48-S5	47 µF/100 V	47 µF/100 V	47 µF/100 V	3300 pF/2 kV	3300 pF/2 kV	1000 pF/2 kV	1.5 mH	3.4 µH	NC
VHK50W-Q48-S12	47 µF/100 V	47 µF/100 V	47 µF/100 V	3300 pF/2 kV	3300 pF/2 kV	1000 pF/2 kV	1.5 mH	3.4 µH	NC
VHK50W-Q48-S15	47 µF/100 V	47 µF/100 V	47 µF/100 V	3300 pF/2 kV	3300 pF/2 kV	1000 pF/2 kV	1.5 mH	3.4 µH	NC
VHK50W-Q48-S24	47 µF/100 V	47 µF/100 V	47 µF/100 V	3300 pF/2 kV	3300 pF/2 kV	1000 pF/2 kV	1.5 mH	3.4 µH	NC
VHK50W-Q48-S28	100 µF/100 V	100 µF/100 V	NC	NC	1000 pF/2 kV	NC	0.12 mH	0.34 mH	NC
VHK50W-Q48-S48	47 µF/100 V	47 µF/100 V	47 µF/100 V	4700 pF/2 kV	2200 pF/2 kV	1000 pF/2 kV	1.5 mH	3.4 µH	47 µF

Note: 1. Ceramic capacitors
2. Aluminum capacitors

APPLICATION NOTES

1. Output Voltage Trimming

Leave open if not used.

Figure 7

Application Circuit for Trim pin

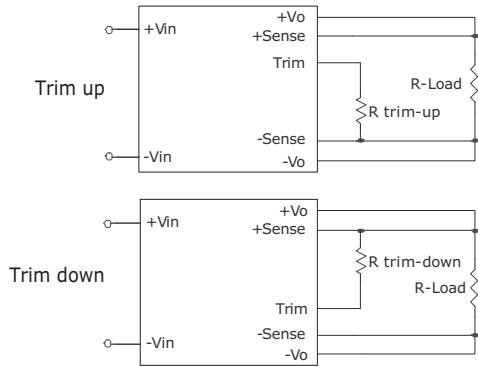

Formula for Trim Resistor

$$R_{trim - up} = \left(\frac{R_1(V_f - V_f(\frac{R_2}{R_2 + R_3}))}{V_o - V_{o, nom}} \right) - \frac{R_2 R_3}{R_2 + R_3} (K\Omega)$$

$$R_{trim - down} = \frac{R_1(V_o - V_f)}{V_{o, nom} - V_o} - R_2 (K\Omega)$$

Note: $R_{trim-up}$ is the external resistor in $K\Omega$
 $R_{trim-down}$ is the external resistor in $K\Omega$
 $V_{o, nom}$ is the nominal output voltage
 V_o is the desired output voltage
 $R_1, R_2, R_3,$ and V_f are internal (see Table 4).

Table 4

Vout (Vdc)	R1 (K Ω)	R2 (K Ω)	R3 (K Ω)	Vr (V)	Vf (V)
3.3	3	12	18	1.24	0.46
5	2.32	8.2	0	2.5	0
12	9.1	51	18	2.5	0.46
15	12	82	18	2.5	0.46
24	20	100	20	2.5	0.46
28	23.7	150	16	2.5	0.46
48	36	270	14	2.5	0.46

REVISION HISTORY

rev.	description	date
1.0	initial release	12/17/2013
1.01	changed DIN-rail mount	06/16/2014

The revision history provided is for informational purposes only and is believed to be accurate.

**CUI INC**[®]

Headquarters
20050 SW 112th Ave.
Tualatin, OR 97062
800.275.4899

Fax 503.612.2383
cui.com
techsupport@cui.com

CUI offers a two (2) year limited warranty. Complete warranty information is listed on our website.

CUI reserves the right to make changes to the product at any time without notice. Information provided by CUI is believed to be accurate and reliable. However, no responsibility is assumed by CUI for its use, nor for any infringements of patents or other rights of third parties which may result from its use.

CUI products are not authorized or warranted for use as critical components in equipment that requires an extremely high level of reliability. A critical component is any component of a life support device or system whose failure to perform can be reasonably expected to cause the failure of the life support device or system, or to affect its safety or effectiveness.