

UZR 3.95mmLmax. Chip Type

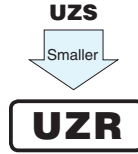

- Chip type with 3.95mmLmax height.
- Designed for surface mounting on high density PC board.
- Applicable to automatic mounting machine fed with carrier tape.
- Compliant to the RoHS directive (2011/65/EU, (EU)2015/863).
- AEC-Q200 compliant. Please contact us for details.

Products which are scheduled to be discontinued.
Not recommended for new designs.

Specifications

Item	Performance Characteristics																	
Category Temperature Range	-40 to +85°C																	
Rated Voltage Range	4 to 50V																	
Rated Capacitance Range	1 to 220μF																	
Capacitance Tolerance	±20% at 120Hz, 20°C																	
Leakage Current ※	After 2 minutes' application of rated voltage at 20°C, leakage current is not more than 0.01 CV or 3 (μA), whichever is greater.																	
Tangent of loss angle (tan δ)	Rated voltage (V)	4	6.3	10	16	25	35	50	120Hz 20°C									
	tan δ (max.)	0.50	0.30	0.24	0.19	0.16	0.14	0.14										
Stability at Low Temperature	Rated voltage (V)	4	6.3	10	16	25	35	50	120Hz									
	Impedance ratio ZT / Z20 (max.)	Z(-25°C) / Z(+20°C)	7	4	3	2	2	2		2								
		Z(-40°C) / Z(+20°C)	15	8	8	4	4	3		3								
Endurance	The specifications listed at right shall be met when the capacitors are restored to 20°C after the rated voltage is applied for 1000 hours at 85°C.																	
										Capacitance change	Within ±30% of the initial capacitance value							
										tan δ	300% or less than the initial specified value							
Shelf Life	After storing the capacitors under no load at 85°C for 1000 hours and then performing voltage treatment based on JIS C 5101-4 clause 4.1 at 20°C, they shall meet the specified values for the endurance characteristics listed above.																	
										Leakage current	Less than or equal to the initial specified value							
										tan δ	Less than or equal to the initial specified value							
Resistance to soldering heat	The capacitors are kept on a hot plate for 30 seconds, which is maintained at 250°C. The capacitors shall meet the characteristic requirements listed at right when they are removed from the plate and restored to 20°C.																	
										Capacitance change	Within ±10% of the initial capacitance value							
										Leakage current	Less than or equal to the initial specified value							
Marking	Black print on the case top.																	

※ I : Leakage Current (μA), C : Rated Capacitance (μF), V : Rated Voltage (V)

Chip Type

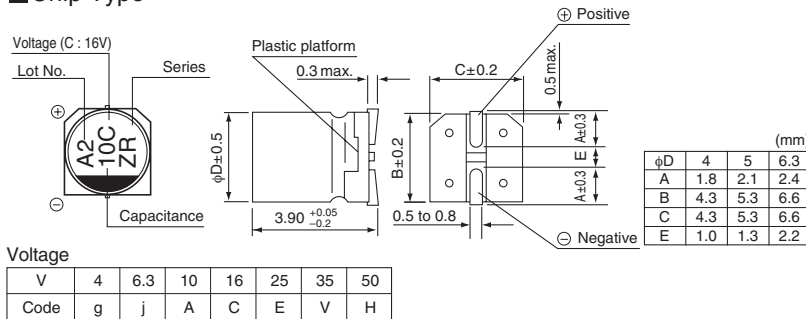

Type numbering system (Example : 16V 10μF)

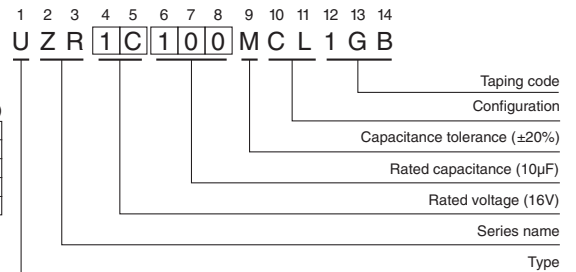

Frequency coefficient of rated ripple current

Frequency	50 Hz	120 Hz	300 Hz	1 kHz	10 kHz or more
Coefficient	0.70	1.00	1.17	1.36	1.50

● Dimension table in next page.

UZR

■Dimensions

Rated Voltage (V) (code)	Rated Capacitance (μ F)	Case Size ϕ D \times L (mm)	$\tan \delta$	Leakage Current (μ A) (at 20°C after 2 minutes)	Rated Ripple (mArms) (85°C/120Hz)	Part Number
4 (0G)	33	4 \times 3.9	0.50	3	28	UZR0G330MCL1GB
	47	4 \times 3.9	0.50	3	33	UZR0G470MCL1GB
	100	5 \times 3.9	0.50	4	56	UZR0G101MCL1GB
	220	6.3 \times 3.9	0.50	8.8	96	UZR0G221MCL1GB
6.3 (0J)	22	4 \times 3.9	0.30	3	28	UZR0J220MCL1GB
	33	5 \times 3.9	0.30	3	37	UZR0J330MCL1GB
	47	5 \times 3.9	0.30	3	45	UZR0J470MCL1GB
	100	6.3 \times 3.9	0.30	6.3	70	UZR0J101MCL1GB
10 (1A)	22	5 \times 3.9	0.24	3	33	UZR1A220MCL1GB
	33	5 \times 3.9	0.24	3.3	41	UZR1A330MCL1GB
	47	6.3 \times 3.9	0.24	4.7	52	UZR1A470MCL1GB
16 (1C)	10	4 \times 3.9	0.19	3	23	UZR1C100MCL1GB
	22	5 \times 3.9	0.19	3.52	37	UZR1C220MCL1GB
	33	6.3 \times 3.9	0.19	5.28	49	UZR1C330MCL1GB
	47	6.3 \times 3.9	0.19	7.52	58	UZR1C470MCL1GB
25 (1E)	4.7	4 \times 3.9	0.16	3	16	UZR1E470MCL1GB
	10	5 \times 3.9	0.16	3	27	UZR1E100MCL1GB
	22	6.3 \times 3.9	0.16	5.5	42	UZR1E220MCL1GB
	33	6.3 \times 3.9	0.16	8.25	52	UZR1E330MCL1GB
35 (1V)	4.7	4 \times 3.9	0.14	3	18	UZR1V470MCL1GB
	10	5 \times 3.9	0.14	3.5	29	UZR1V100MCL1GB
	22	6.3 \times 3.9	0.14	7.7	46	UZR1V220MCL1GB
50 (1H)	1	4 \times 3.9	0.14	3	8.4	UZR1H010MCL1GB
	2.2	4 \times 3.9	0.14	3	13	UZR1H2R2MCL1GB
	3.3	4 \times 3.9	0.14	3	17	UZR1H3R3MCL1GB
	4.7	5 \times 3.9	0.14	3	20	UZR1H4R7MCL1GB
	10	6.3 \times 3.9	0.14	5	33	UZR1H100MCL1GB

- For taping specifications, recommended land size/soldering by reflow and minimum order quantity, please refer to the Guidelines for Aluminum Electrolytic Capacitors.

UZG

3.95mmLmax. Chip Type,
Wide Temperature Range



For SMD



Smaller



Anti-Solvent
Feature

- Chip type with 3.95mmLmax height. Operating over wide temperature range of -40 to +105°C.
- Designed for surface mounting on high density PC board.
- Applicable to automatic mounting machine fed with carrier tape.
- Compliant to the RoHS directive (2011/65/EU,(EU)2015/863).
- AEC-Q200 compliant. Please contact us for details.

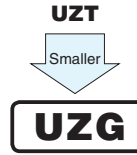

Specifications

Item	Performance Characteristics								
Category Temperature Range	-40 to +105°C								
Rated Voltage Range	6.3 to 50V								
Rated Capacitance Range	1 to 100μF								
Capacitance Tolerance	±20% at 120Hz, 20°C								
Leakage Current ※	After 2 minutes' application of rated voltage at 20°C, leakage current is not more than 0.01 CV or 3 (μA) , whichever is greater.								
Tangent of loss angle (tan δ)	Rated voltage (V)	6.3	10	16	25	35	50	120Hz 20°C	
	tan δ (max.)	0.38	0.32	0.20	0.16	0.14	0.14		
Stability at Low Temperature	Rated voltage (V)	6.3	10	16	25	35	50	120Hz	
	Impedance ratio ZT / Z20 (max.)	Z(-25°C) / Z(+20°C)	6	5	3	3	3		3
		Z(-40°C) / Z(+20°C)	10	10	6	6	4		4
Endurance	The specifications listed at right shall be met when the capacitors are restored to 20°C after the rated voltage is applied for 1000 hours at 105°C.							Capacitance change	Within ±30% of the initial capacitance value
								tan δ	300% or less than the initial specified value
								Leakage current	Less than or equal to the initial specified value
Shelf Life	After storing the capacitors under no load at 105°C for 1000 hours and then performing voltage treatment based on JIS C 5101-4 clause 4.1 at 20°C, they shall meet the specified values for the endurance characteristics listed above.								
Resistance to soldering heat	The capacitors are kept on a hot plate for 30 seconds, which is maintained at 250°C. The capacitors shall meet the characteristic requirements listed at right when they are removed from the plate and restored to 20°C.							Capacitance change	Within ±10% of the initial capacitance value
								tan δ	Less than or equal to the initial specified value
								Leakage current	Less than or equal to the initial specified value
Marking	Black print on the case top.								

※ I : Leakage Current (μA), C : Rated Capacitance (μF), V : Rated Voltage (V)

Chip Type

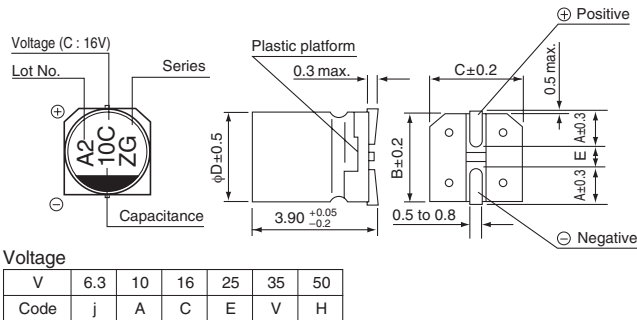

Type numbering system (Example : 16V 10μF)

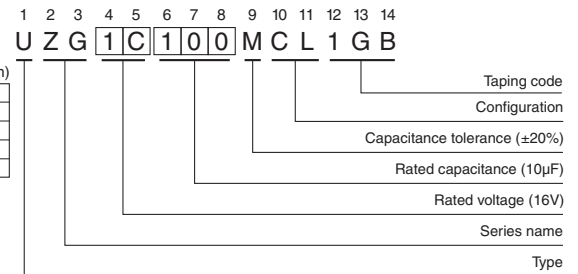

Frequency coefficient of rated ripple current

Frequency	50 Hz	120 Hz	300 Hz	1 kHz	10 kHz or more
Coefficient	0.70	1.00	1.17	1.36	1.50

● Dimension table in next page.

UZG

■ Dimensions

Rated Voltage (V) (code)	Rated Capacitance (μ F)	Case Size ϕ D×L (mm)	tan δ	Leakage Current (μ A) (at 20°C after 2 minutes)	Rated Ripple (mArms) (105°C/120Hz)	Part Number
6.3 (0J)	22	4×3.9	0.38	3	19	UZG0J220MCL1GB
	33	5×3.9	0.38	3	26	UZG0J330MCL1GB
	47	5×3.9	0.38	3	32	UZG0J470MCL1GB
	100	6.3×3.9	0.38	6.3	52	UZG0J101MCL1GB
10 (1A)	22	5×3.9	0.32	3	24	UZG1A220MCL1GB
	33	5×3.9	0.32	3.3	30	UZG1A330MCL1GB
	47	6.3×3.9	0.32	4.7	40	UZG1A470MCL1GB
16 (1C)	10	4×3.9	0.20	3	16	UZG1C100MCL1GB
	22	5×3.9	0.20	3.52	26	UZG1C220MCL1GB
	33	6.3×3.9	0.20	5.28	35	UZG1C330MCL1GB
	47	6.3×3.9	0.20	7.52	44	UZG1C470MCL1GB
25 (1E)	4.7	4×3.9	0.16	3	11	UZG1E4R7MCL1GB
	10	5×3.9	0.16	3	20	UZG1E100MCL1GB
	22	6.3×3.9	0.16	5.5	33	UZG1E220MCL1GB
	33	6.3×3.9	0.16	8.25	42	UZG1E330MCL1GB
35 (1V)	4.7	4×3.9	0.14	3	13	UZG1V4R7MCL1GB
	10	5×3.9	0.14	3.5	22	UZG1V100MCL1GB
	22	6.3×3.9	0.14	7.7	36	UZG1V220MCL1GB
50 (1H)	1	4×3.9	0.14	3	5.4	UZG1H010MCL1GB
	2.2	4×3.9	0.14	3	9.6	UZG1H2R2MCL1GB
	3.3	4×3.9	0.14	3	12	UZG1H3R3MCL1GB
	4.7	5×3.9	0.14	3	16	UZG1H4R7MCL1GB
	10	6.3×3.9	0.14	5	26	UZG1H100MCL1GB

- For taping specifications, recommended land size/soldering by reflow and minimum order quantity, please refer to the Guidelines for Aluminum Electrolytic Capacitors.

UZS 4.5mmL Chip Type



- Chip type with 4.5mm height.
- Designed for surface mounting on high density PC board.
- Applicable to automatic mounting machine fed with carrier tape.
- Compliant to the RoHS directive (2011/65/EU, (EU)2015/863).
- AEC-Q200 compliant. Please contact us for details.

Products which are scheduled to be discontinued.
Not recommended for new designs.

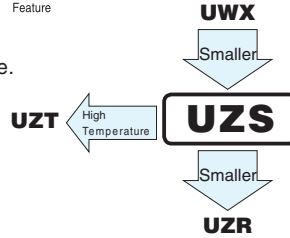

Specifications

Item	Performance Characteristics							
Category Temperature Range	-40 to + 85°C							
Rated Voltage Range	4 to 50V							
Rated Capacitance Range	1 to 220μF							
Capacitance Tolerance	±20% at 120Hz, 20°C							
Leakage Current ※	After 2 minutes' application of rated voltage at 20°C, leakage current is not more than 0.01 CV or 3 (μA) ,whichever is greater.							
Tangent of loss angle (tan δ)	Measurement frequency : 120Hz at 20°C							
	Rated voltage (V)	4	6.3	10	16	25	35	50
Stability at Low Temperature	Measurement frequency : 120Hz							
	Rated voltage (V)	4	6.3	10	16	25	35	50
Endurance	The specifications listed at right shall be met when the capacitors are restored to 20°C after the rated voltage is applied for 2000 hours at 85°C.							
	Capacitance change	Within ±20% of the initial capacitance value						
Shelf Life	After storing the capacitors under no load at 85°C for 1000 hours and then performing voltage treatment based on JIS C 5101-4 clause 4.1 at 20°C, they shall meet the specified values for the endurance characteristics listed above.							
	tan δ	200% or less than the initial specified value						
Resistance to soldering heat	The capacitors are kept on a hot plate for 30 seconds, which is maintained at 250°C. The capacitors shall meet the characteristic requirements listed at right when they are removed from the plate and restored to 20°C.							
	Leakage current	Less than or equal to the initial specified value						
Marking	Black print on the case top.							
	Capacitance change	Within ±10% of the initial capacitance value						
Marking	Black print on the case top.							
	tan δ	Less than or equal to the initial specified value						
Marking	Black print on the case top.							
	Leakage current	Less than or equal to the initial specified value						

※ I : Leakage Current (μA), C : Rated Capacitance (μF), V : Rated Voltage (V)

Chip Type

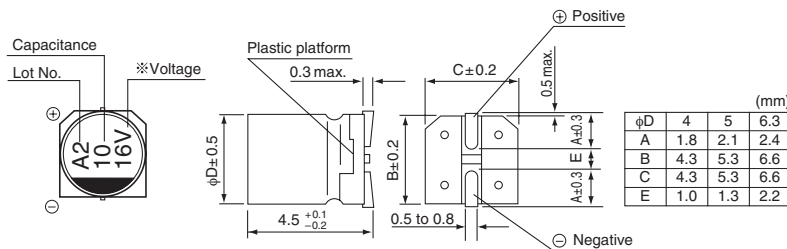

Type numbering system (Example : 16V 10μF)

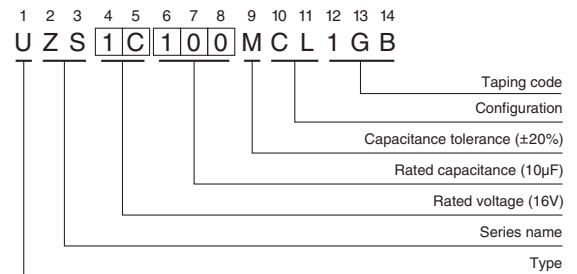

Frequency coefficient of rated ripple current

Frequency	50 Hz	120 Hz	300 Hz	1 kHz	10 kHz or more
Coefficient	0.70	1.00	1.17	1.36	1.50

● Dimension table in next page.

UZS

■ Dimensions

Rated Voltage (V) (code)	Rated Capacitance (μF)	Case Size φD×L (mm)	tan δ	Leakage Current (μA) (at 20°C after 2 minutes)	Rated Ripple (mArms) (85°C/120Hz)	Part Number
4 (0G)	33	4×4.5	0.50	3	28	UZS0G330MCL1GB
	47	4×4.5	0.50	3	33	UZS0G470MCL1GB
	100	5×4.5	0.50	4	56	UZS0G101MCL1GB
	220	6.3×4.5	0.50	8.8	96	UZS0G221MCL1GB
6.3 (0J)	22	4×4.5	0.30	3	28	UZS0J220MCL1GB
	33	5×4.5	0.30	3	37	UZS0J330MCL1GB
	47	5×4.5	0.30	3	45	UZS0J470MCL1GB
	100	6.3×4.5	0.30	6.3	70	UZS0J101MCL1GB
10 (1A)	22	5×4.5	0.24	3	33	UZS1A220MCL1GB
	33	5×4.5	0.24	3.3	41	UZS1A330MCL1GB
	47	6.3×4.5	0.24	4.7	52	UZS1A470MCL1GB
16 (1C)	10	4×4.5	0.19	3	23	UZS1C100MCL1GB
	22	5×4.5	0.19	3.52	37	UZS1C220MCL1GB
	33	6.3×4.5	0.19	5.28	49	UZS1C330MCL1GB
	47	6.3×4.5	0.19	7.52	58	UZS1C470MCL1GB
25 (1E)	4.7	4×4.5	0.16	3	16	UZS1E4R7MCL1GB
	10	5×4.5	0.16	3	27	UZS1E100MCL1GB
	22	6.3×4.5	0.16	5.5	42	UZS1E220MCL1GB
	33	6.3×4.5	0.16	8.25	52	UZS1E330MCL1GB
35 (1V)	4.7	4×4.5	0.14	3	18	UZS1V4R7MCL1GB
	10	5×4.5	0.14	3.5	29	UZS1V100MCL1GB
	22	6.3×4.5	0.14	7.7	46	UZS1V220MCL1GB
50 (1H)	1	4×4.5	0.14	3	8.4	UZS1H010MCL1GB
	2.2	4×4.5	0.14	3	13	UZS1H2R2MCL1GB
	3.3	4×4.5	0.14	3	17	UZS1H3R3MCL1GB
	4.7	5×4.5	0.14	3	20	UZS1H4R7MCL1GB
	10	6.3×4.5	0.14	5	33	UZS1H100MCL1GB

- For taping specifications, recommended land size/soldering by reflow and minimum order quantity, please refer to the Guidelines for Aluminum Electrolytic Capacitors.
- Please select UUR, UUG if high C/V products are required.

UZT 4.5mmL Chip Type, Wide Temperature Range

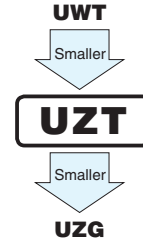

- Chip type with 4.5mm height, operating over wide temperature range of -40 to +105°C.
- Designed for surface mounting on high density PC board.
- Applicable to automatic mounting machine fed with carrier tape.
- Compliant to the RoHS directive (2011/65/EU, (EU)2015/863).
- AEC-Q200 compliant. Please contact us for details.

Specifications

Item	Performance Characteristics						
Category Temperature Range	-40 to +105°C						
Rated Voltage Range	6.3 to 50V						
Rated Capacitance Range	1 to 100µF						
Capacitance Tolerance	±20% at 120Hz, 20°C						
Leakage Current ※	After 2 minutes' application of rated voltage at 20°C, leakage current is not more than 0.01CV or 3 (µA), whichever is greater.						
Tangent of loss angle (tan δ)	Measurement frequency : 120Hz at 20°C						
	Rated voltage (V)	6.3	10	16	25	35	50
Stability at Low Temperature	Measurement frequency : 120Hz						
	Rated voltage (V)	6.3	10	16	25	35	50
	Impedance ratio Z(-25°C) / Z(+20°C)	6	5	3	3	3	3
Endurance	The specifications listed at right shall be met when the capacitors are restored to 20°C after the rated voltage is applied for 1000 hours at 105°C.						
	Capacitance change	Within ±25% of the initial capacitance value (16V or less) Within ±20% of the initial capacitance value (25V or more)					
	tan δ	300% or less than initial specified value					
Shelf Life	After storing the capacitors under no load at 105°C for 1000 hours and then performing voltage treatment based on JIS C 5101-4 clause 4.1 at 20°C, they shall meet the specified values for the endurance characteristics listed above.						
	The capacitors are kept on a hot plate for 30 seconds, which is maintained at 250°C. The capacitors shall meet the characteristic requirements listed at right when they are removed from the plate and restored to 20°C.						
	Leakage current	Less than or equal to the initial specified value					
Resistance to soldering heat	The capacitors are kept on a hot plate for 30 seconds, which is maintained at 250°C. The capacitors shall meet the characteristic requirements listed at right when they are removed from the plate and restored to 20°C.						
	Capacitance change	Within ±10% of the initial capacitance value					
	tan δ	Less than or equal to the initial specified value					
Marking	Black print on the case top.						
	Leakage current	Less than or equal to the initial specified value					

※ I : Leakage Current (µA), C : Rated Capacitance (µF), V : Rated Voltage (V)

Chip Type

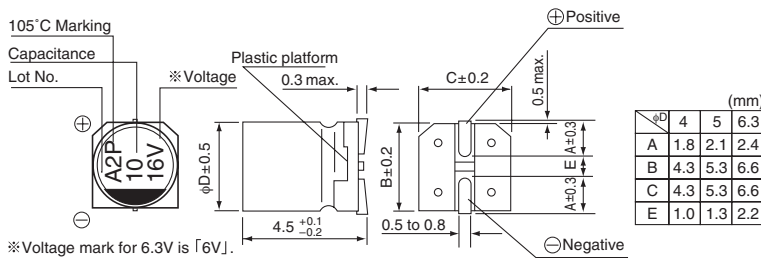

Type numbering system (Example : 16V 10µF)

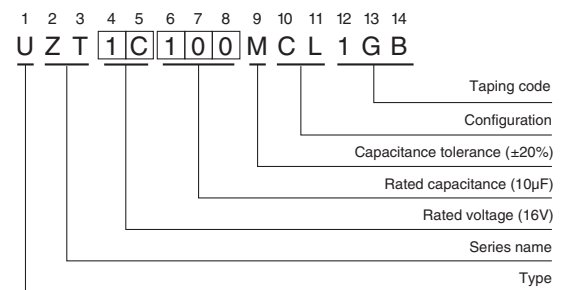

Frequency coefficient of rated ripple current

Frequency	50 Hz	120 Hz	300 Hz	1 kHz	10 kHz or more
Coefficient	0.70	1.00	1.17	1.36	1.50

● Dimension table in next page.

UZZ

■ Dimensions

Rated Voltage (V) (code)	Rated Capacitance (μF)	Case Size φD×L (mm)	tan δ	Leakage Current (μA) (at 20°C after 2 minutes)	Rated Ripple (mArms) (105°C/120Hz)	Part Number
6.3 (0J)	22	4×4.5	0.38	3	19	UZZ0J220MCL1GB
	33	5×4.5	0.38	3	26	UZZ0J330MCL1GB
	47	5×4.5	0.38	3	32	UZZ0J470MCL1GB
	100	6.3×4.5	0.38	6.3	52	UZZ0J101MCL1GB
10 (1A)	22	5×4.5	0.32	3	24	UZZ1A220MCL1GB
	33	5×4.5	0.32	3.3	30	UZZ1A330MCL1GB
	47	6.3×4.5	0.32	4.7	40	UZZ1A470MCL1GB
16 (1C)	10	4×4.5	0.20	3	16	UZZ1C100MCL1GB
	22	5×4.5	0.20	3.52	26	UZZ1C220MCL1GB
	33	6.3×4.5	0.20	5.28	35	UZZ1C330MCL1GB
	47	6.3×4.5	0.20	7.52	44	UZZ1C470MCL1GB
25 (1E)	4.7	4×4.5	0.16	3	11	UZZ1E4R7MCL1GB
	10	5×4.5	0.16	3	20	UZZ1E100MCL1GB
	22	6.3×4.5	0.16	5.5	33	UZZ1E220MCL1GB
	33	6.3×4.5	0.16	8.25	42	UZZ1E330MCL1GB
35 (1V)	4.7	4×4.5	0.14	3	13	UZZ1V4R7MCL1GB
	10	5×4.5	0.14	3.5	22	UZZ1V100MCL1GB
	22	6.3×4.5	0.14	7.7	36	UZZ1V220MCL1GB
50 (1H)	1	4×4.5	0.14	3	5.4	UZZ1H010MCL1GB
	2.2	4×4.5	0.14	3	9.6	UZZ1H2R2MCL1GB
	3.3	4×4.5	0.14	3	12	UZZ1H3R3MCL1GB
	4.7	5×4.5	0.14	3	16	UZZ1H4R7MCL1GB
	10	6.3×4.5	0.14	5	26	UZZ1H100MCL1GB

- For taping specifications, recommended land size/soldering by reflow and minimum order quantity, please refer to the Guidelines for Aluminum Electrolytic Capacitors.
- Please select UUX, UUU series if high C/V products are required.

ALUMINUM ELECTROLYTIC CAPACITORS

UWX

5.5mmL Chip Type



For SMD



Anti-Solvent Feature

- Chip type with 5.5mm height.
- Designed for surface mounting on high density PC board.
- Applicable to automatic mounting machine fed with carrier tape.
- Load life of 2000 hours at 85°C.
- Compliant to the RoHS directive (2011/65/EU,(EU)2015/863).
- AEC-Q200 compliant. Please contact us for details.

Products which are scheduled to be discontinued.
Not recommended for new designs.

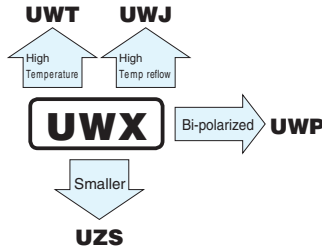

Specifications

Item	Performance Characteristics																								
Category Temperature Range	-40 to +85°C																								
Rated Voltage Range	4 to 50V																								
Rated Capacitance Range	1 to 330μF																								
Capacitance Tolerance	±20% at 120Hz, 20°C																								
Leakage Current ※	After 2 minutes' application of rated voltage at 20°C, leakage current is not more than 0.01CV or 3 (μA) ,whichever is greater.																								
Tangent of loss angle (tan δ)	<p>Measurement frequency : 120Hz at 20°C</p> <table border="1"> <thead> <tr> <th>Rated voltage (V)</th> <th>4</th> <th>6.3</th> <th>10</th> <th>16</th> <th>25</th> <th>35</th> <th>50</th> </tr> </thead> <tbody> <tr> <td>tan δ (max.)</td> <td>0.35 (0.40)</td> <td>0.26 (0.30)</td> <td>0.20 (0.24)</td> <td>0.16 (0.19)</td> <td>0.14 (0.16)</td> <td>0.12 (0.14)</td> <td>0.12 (0.14)</td> </tr> </tbody> </table> <p>Values in () applicable to WR.</p>	Rated voltage (V)	4	6.3	10	16	25	35	50	tan δ (max.)	0.35 (0.40)	0.26 (0.30)	0.20 (0.24)	0.16 (0.19)	0.14 (0.16)	0.12 (0.14)	0.12 (0.14)								
Rated voltage (V)	4	6.3	10	16	25	35	50																		
tan δ (max.)	0.35 (0.40)	0.26 (0.30)	0.20 (0.24)	0.16 (0.19)	0.14 (0.16)	0.12 (0.14)	0.12 (0.14)																		
Stability at Low Temperature	<p>Measurement frequency : 120Hz</p> <table border="1"> <thead> <tr> <th>Rated voltage (V)</th> <th>4</th> <th>6.3</th> <th>10</th> <th>16</th> <th>25</th> <th>35</th> <th>50</th> </tr> </thead> <tbody> <tr> <td>Impedance ratio Z(-25°C) / Z(+20°C)</td> <td>7</td> <td>4</td> <td>3</td> <td>2</td> <td>2</td> <td>2</td> <td>2</td> </tr> <tr> <td>ZT / Z20 (max.)</td> <td>15</td> <td>8</td> <td>8</td> <td>4</td> <td>4</td> <td>3</td> <td>3</td> </tr> </tbody> </table>	Rated voltage (V)	4	6.3	10	16	25	35	50	Impedance ratio Z(-25°C) / Z(+20°C)	7	4	3	2	2	2	2	ZT / Z20 (max.)	15	8	8	4	4	3	3
Rated voltage (V)	4	6.3	10	16	25	35	50																		
Impedance ratio Z(-25°C) / Z(+20°C)	7	4	3	2	2	2	2																		
ZT / Z20 (max.)	15	8	8	4	4	3	3																		
Endurance	<p>The specifications listed at right shall be met when the capacitors are restored to 20°C after the rated voltage is applied for 2000 hours at 85°C.</p> <table border="1"> <tbody> <tr> <td>Capacitance change</td> <td>Within ±20% of the initial capacitance value (Within ±25% for 4 V and WR series units)</td> </tr> <tr> <td>tan δ</td> <td>200% or less than the initial specified value</td> </tr> <tr> <td>Leakage Current</td> <td>Less than or equal to the initial specified value</td> </tr> </tbody> </table>	Capacitance change	Within ±20% of the initial capacitance value (Within ±25% for 4 V and WR series units)	tan δ	200% or less than the initial specified value	Leakage Current	Less than or equal to the initial specified value																		
Capacitance change	Within ±20% of the initial capacitance value (Within ±25% for 4 V and WR series units)																								
tan δ	200% or less than the initial specified value																								
Leakage Current	Less than or equal to the initial specified value																								
Shelf Life	After storing the capacitors under no load at 85°C for 1000 hours and then performing voltage treatment based on JIS C 5101-4 clause 4.1 at 20°C, they shall meet the specified values for the endurance characteristics listed above.																								
Resistance to soldering heat	<p>The capacitors are kept on a hot plate for 30 seconds, which is maintained at 250°C. The capacitors shall meet the characteristic requirements listed at right when they are removed from the plate and restored to 20°C.</p> <table border="1"> <tbody> <tr> <td>Capacitance change</td> <td>Within ±10% of the initial capacitance value</td> </tr> <tr> <td>tan δ</td> <td>Less than or equal to the initial specified value</td> </tr> <tr> <td>Leakage current</td> <td>Less than or equal to the initial specified value</td> </tr> </tbody> </table>	Capacitance change	Within ±10% of the initial capacitance value	tan δ	Less than or equal to the initial specified value	Leakage current	Less than or equal to the initial specified value																		
Capacitance change	Within ±10% of the initial capacitance value																								
tan δ	Less than or equal to the initial specified value																								
Leakage current	Less than or equal to the initial specified value																								
Marking	Black print on the case top.																								

※ I : Leakage Current (μA), C : Rated Capacitance (μF), V : Rated Voltage (V)

Chip Type

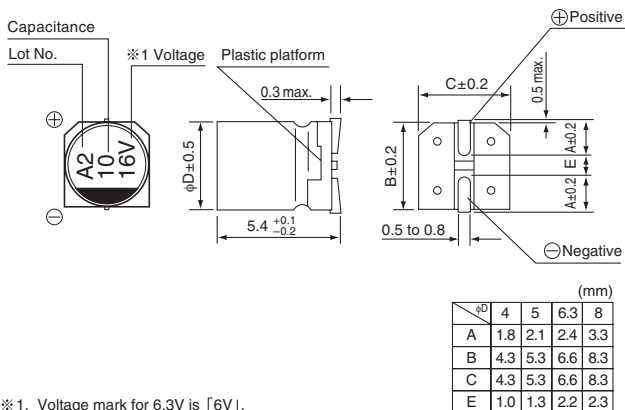

※ 1. Voltage mark for 6.3V is 「6V」.

Type numbering system (Example : 16V 10μF)

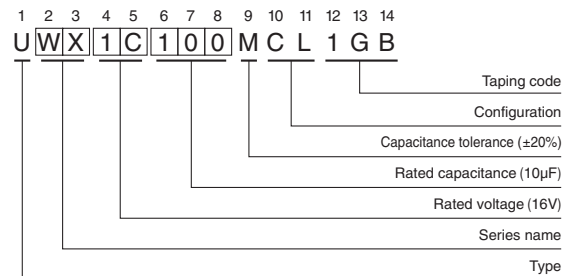

Frequency coefficient of rated ripple current

Frequency	50 Hz	120 Hz	300 Hz	1 kHz	10 kHz or more
Coefficient	0.70	1.00	1.17	1.36	1.50

● Dimension table in next page.



■ Dimensions

Rated Voltage (V) (code)	Rated Capacitance (μF)	Case Size φD×L (mm)	tan δ	Leakage Current (μA) (at 20°C after 2 minutes)	Rated Ripple (mArms) (85°C/120Hz)	Part Number
4 (0G)	33	4×5.4	0.35	3	28	UWX0G330MCL1GB
	47	4×5.4	0.35	3	33	UWX0G470MCL1GB
	56	5×5.4	0.35	3	42	UWX0G560MCL1GB
	100	5×5.4	0.35	4	56	UWX0G101MCL1GB
	150	6.3×5.4	0.35	6	79	UWX0G151MCL1GB
	220	6.3×5.4	0.35	8.8	96	UWX0G221MCL1GB
	330	8×5.4	0.35	13.2	145	UWX0G331MCL1GB
6.3 (0J)	22	4×5.4	0.26	3	28	UWX0J220MCL1GB
	33	5×5.4	0.26	3	37	UWX0J330MCL1GB
	33	4×5.4	0.30	3	34	UWR0J330MCL1GB
	47	5×5.4	0.26	3	45	UWX0J470MCL1GB
	47	4×5.4	0.30	3	40	UWR0J470MCL1GB
	56	6.3×5.4	0.26	3.528	52	UWX0J560MCL1GB
	56	5×5.4	0.30	3.528	46	UWR0J560MCL1GB
	100	6.3×5.4	0.26	6.3	70	UWX0J101MCL1GB
	100	5×5.4	0.30	6.3	47	UWR0J101MCL1GB
	150	6.3×5.4	0.26	9.45	71	UWX0J151MCL1GB
	220	8×5.4	0.26	13.86	110	UWX0J221MCL1GB
	220	6.3×5.4	0.30	13.86	74	UWR0J221MCL1GB
	330	8×5.4	0.26	20.79	170	UWX0J331MCL1GB
10 (1A)	22	5×5.4	0.20	3	33	UWX1A220MCL1GB
	22	4×5.4	0.24	3	30	UWR1A220MCL1GB
	33	5×5.4	0.20	3.3	41	UWX1A330MCL1GB
	33	4×5.4	0.24	3.3	34	UWR1A330MCL1GB
	47	6.3×5.4	0.20	4.7	52	UWX1A470MCL1GB
	47	5×5.4	0.24	4.7	47	UWR1A470MCL1GB
	56	6.3×5.4	0.20	5.6	57	UWX1A560MCL1GB
	56	5×5.4	0.24	5.6	50	UWR1A560MCL1GB
	100	6.3×5.4	0.20	10	76	UWX1A101MCL1GB
	100	5×5.4	0.24	10	54	UWR1A101MCL1GB
	150	8×5.4	0.20	15	111	UWX1A151MCL1GB
	150	6.3×5.4	0.24	15	76	UWR1A151MCL1GB
	220	8×5.4	0.20	22	135	UWX1A221MCL1GB
16 (1C)	10	4×5.4	0.16	3	23	UWX1C100MCL1GB
	22	5×5.4	0.16	3.52	37	UWX1C220MCL1GB
	22	4×5.4	0.19	3.52	30	UWR1C220MCL1GB
	33	6.3×5.4	0.16	5.28	49	UWX1C330MCL1GB
	33	5×5.4	0.19	5.28	44	UWR1C330MCL1GB
	47	6.3×5.4	0.16	7.52	58	UWX1C470MCL1GB
	47	5×5.4	0.19	7.52	52	UWR1C470MCL1GB
	56	6.3×5.4	0.16	8.96	63	UWX1C560MCL1GB
	56	5×5.4	0.19	8.96	57	UWR1C560MCL1GB
	100	6.3×5.4	0.16	16	86	UWX1C101MCL1GB



■ Dimensions

Rated Voltage (V) (code)	Rated Capacitance (μF)	Case Size φD×L (mm)	tan δ	Leakage Current (μA) (at 20°C after 2 minutes)	Rated Ripple (mArms) (85°C/120Hz)	Part Number
25 (1E)	4.7	4×5.4	0.14	3	16	UWX1E4R7MCL1GB
	10	5×5.4	0.14	3	27	UWX1E100MCL1GB
	10	4×5.4	0.16	3	24	UWR1E100MCL1GB
	22	6.3×5.4	0.14	5.5	42	UWX1E220MCL1GB
	22	5×5.4	0.16	5.5	38	UWR1E220MCL1GB
	33	6.3×5.4	0.14	8.25	52	UWX1E330MCL1GB
	33	5×5.4	0.16	8.25	46	UWR1E330MCL1GB
	47	8×5.4	0.14	11.75	70	UWX1E470MCL1GB
	47	6.3×5.4	0.16	11.75	60	UWR1E470MCL1GB
	56	8×5.4	0.14	14	76	UWX1E560MCL1GB
	56	6.3×5.4	0.16	14	65	UWR1E560MCL1GB
100	8×5.4	0.14	25	110	UWX1E101MCL1GB	
35 (1V)	4.7	4×5.4	0.12	3	18	UWX1V4R7MCL1GB
	10	5×5.4	0.12	3.5	29	UWX1V100MCL1GB
	10	4×5.4	0.14	3.5	24	UWR1V100MCL1GB
	22	6.3×5.4	0.12	7.7	46	UWX1V220MCL1GB
	22	5×5.4	0.14	7.7	39	UWR1V220MCL1GB
	33	8×5.4	0.12	11.55	62	UWX1V330MCL1GB
	33	6.3×5.4	0.14	11.55	53	UWR1V330MCL1GB
	47	8×5.4	0.12	16.45	80	UWX1V470MCL1GB
50 (1H)	1	4×5.4	0.12	3	8.4	UWX1H010MCL1GB
	2.2	4×5.4	0.12	3	13	UWX1H2R2MCL1GB
	3.3	4×5.4	0.12	3	17	UWX1H3R3MCL1GB
	4.7	5×5.4	0.12	3	20	UWX1H4R7MCL1GB
	4.7	4×5.4	0.14	3	18	UWR1H4R7MCL1GB
	10	6.3×5.4	0.12	5	33	UWX1H100MCL1GB
	10	5×5.4	0.14	5	30	UWR1H100MCL1GB
	22	8×5.4	0.12	11	52	UWX1H220MCL1GB
	22	6.3×5.4	0.14	11	43	UWR1H220MCL1GB
	33	8×5.4	0.12	16.5	71	UWX1H330MCL1GB

- For taping specifications, recommended land size/soldering by reflow and minimum order quantity, please refer to the Guidelines for Aluminum Electrolytic Capacitors.
- Please select UUR, UUG if high C/V products are required.

ALUMINUM ELECTROLYTIC CAPACITORS

UWJ

5.5mmL Chip Type
High Temperature (260°C) Reflow



- Corresponding with 260°C peak reflow soldering
Recommended reflow condition : 260°C peak 5 sec. 230°C over 60 sec. 2 times
- Chip type with 5.5mm height.
- Designed for surface mounting on high density PC board.
- Applicable to automatic mounting machine fed with carrier tape.
- Load life of 2000 hours at 85°C
- Compliant to the RoHS directive (2011/65/EU,(EU)2015/863).
- AEC-Q200 compliant. Please contact us for details.

UWJ

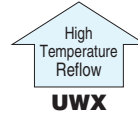

Products which are scheduled to be discontinued.
Not recommended for new designs.

Specifications

Item	Performance Characteristics																											
Category Temperature Range	-40 to +85°C																											
Rated Voltage Range	6.3 to 50V																											
Rated Capacitance Range	1 to 150μF																											
Capacitance Tolerance	±20% at 120Hz, 20°C																											
Leakage Current ※	After 2 minutes' application of rated voltage at 20°C, leakage current is not more than 0.01CV or 3 (μA) ,whichever is greater.																											
Tangent of loss angle (tan δ)	Measurement frequency : 120Hz at 20°C																											
	Rated voltage (V)	6.3	10	16	25	35	50																					
	tan δ (max.)	0.26	0.20	0.16	0.14	0.12	0.12																					
Stability at Low Temperature	Measurement frequency : 120Hz																											
	Rated voltage (V)	6.3	10	16	25	35	50																					
	Impedance ratio Z(-25°C) / Z(+20°C)	4	3	2	2	2	2																					
	ZT / Z20 (max.)	Z(-40°C) / Z(+20°C)	8	8	4	4	3	3																				
Endurance	The specifications listed at right shall be met when the capacitors are restored to 20°C after the rated voltage is applied for 2000 hours at 85°C.		<table border="1"> <tr> <td>Capacitance change</td> <td colspan="6">Within ±20% of the initial capacitance value</td> </tr> <tr> <td>tan δ</td> <td colspan="6">200% or less than the initial specified value</td> </tr> <tr> <td>Leakage Current</td> <td colspan="6">Less than or equal to the initial specified value</td> </tr> </table>					Capacitance change	Within ±20% of the initial capacitance value						tan δ	200% or less than the initial specified value						Leakage Current	Less than or equal to the initial specified value					
	Capacitance change	Within ±20% of the initial capacitance value																										
tan δ	200% or less than the initial specified value																											
Leakage Current	Less than or equal to the initial specified value																											
Shelf Life	After storing the capacitors under no load at 85°C for 1000 hours and then performing voltage treatment based on JIS C 5101-4 clause 4.1 at 20°C, they shall meet the specified values for the endurance characteristics listed above.																											
Resistance to soldering heat	The capacitors are kept on a hot plate for 30 seconds, which is maintained at 250°C. The capacitors shall meet the characteristic requirements listed at right when they are removed from the plate and restored to 20°C.		<table border="1"> <tr> <td>Capacitance change</td> <td colspan="6">Within ±10% of the initial capacitance value</td> </tr> <tr> <td>tan δ</td> <td colspan="6">Less than or equal to the initial specified value</td> </tr> <tr> <td>Leakage current</td> <td colspan="6">Less than or equal to the initial specified value</td> </tr> </table>					Capacitance change	Within ±10% of the initial capacitance value						tan δ	Less than or equal to the initial specified value						Leakage current	Less than or equal to the initial specified value					
	Capacitance change	Within ±10% of the initial capacitance value																										
tan δ	Less than or equal to the initial specified value																											
Leakage current	Less than or equal to the initial specified value																											
Marking	Black print on the case top.																											

※ I : Leakage Current (μA), C : Rated Capacitance (μF), V : Rated Voltage (V)

Chip Type

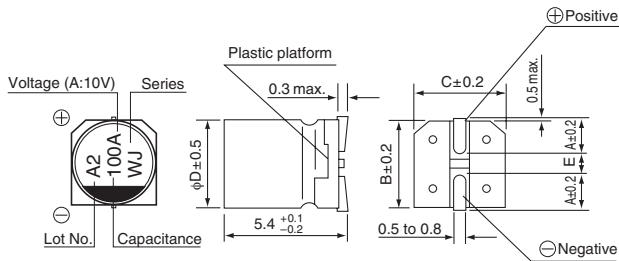

Type numbering system (Example : 16V 10μF)

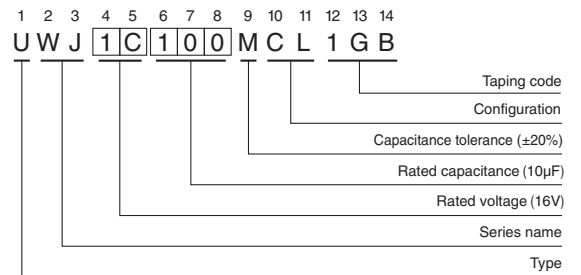

Voltage

V	6.3	10	16	25	35	50
Code	j	A	C	E	V	H

	φD	(mm)		
A	4	1.8	2.1	2.4
B	5	4.3	5.3	6.6
C	6.3	4.3	5.3	6.6
E	10	1.0	1.3	2.2

Frequency coefficient of rated ripple current

Frequency	50 Hz	120 Hz	300 Hz	1 kHz	10 kHz or more
Coefficient	0.70	1.00	1.17	1.36	1.50

● Dimension table in next page.

UWJ

■ Dimensions

Rated Voltage (V) (code)	Rated Capacitance (μF)	Case Size φD×L (mm)	tan δ	Leakage Current (μA) (at 20°C after 2 minutes)	Rated Ripple (mArms) (85°C/120Hz)	Part Number
6.3 (0J)	22	4×5.4	0.26	3	28	UWJ0J220MCL1GB
	33	5×5.4	0.26	3	37	UWJ0J330MCL1GB
	47	5×5.4	0.26	3	45	UWJ0J470MCL1GB
	100	6.3×5.4	0.26	6.3	70	UWJ0J101MCL1GB
	150	6.3×5.4	0.26	9.45	71	UWJ0J151MCL1GB
10 (1A)	22	5×5.4	0.20	3	33	UWJ1A220MCL1GB
	33	5×5.4	0.20	3.3	41	UWJ1A330MCL1GB
	47	6.3×5.4	0.20	4.7	52	UWJ1A470MCL1GB
	100	6.3×5.4	0.20	10	76	UWJ1A101MCL1GB
16 (1C)	10	4×5.4	0.16	3	23	UWJ1C100MCL1GB
	22	5×5.4	0.16	3.52	37	UWJ1C220MCL1GB
	33	6.3×5.4	0.16	5.28	49	UWJ1C330MCL1GB
	47	6.3×5.4	0.16	7.52	58	UWJ1C470MCL1GB
	100	6.3×5.4	0.16	16	86	UWJ1C101MCL1GB
25 (1E)	4.7	4×5.4	0.14	3	16	UWJ1E4R7MCL1GB
	10	5×5.4	0.14	3	27	UWJ1E100MCL1GB
	22	6.3×5.4	0.14	5.5	42	UWJ1E220MCL1GB
	33	6.3×5.4	0.14	8.25	52	UWJ1E330MCL1GB
35 (1V)	4.7	4×5.4	0.12	3	18	UWJ1V4R7MCL1GB
	10	5×5.4	0.12	3.5	29	UWJ1V100MCL1GB
	22	6.3×5.4	0.12	7.7	45	UWJ1V220MCL1GB
50 (1H)	1	4×5.4	0.12	3	8.4	UWJ1H010MCL1GB
	2.2	4×5.4	0.12	3	13	UWJ1H2R2MCL1GB
	3.3	4×5.4	0.12	3	17	UWJ1H3R3MCL1GB
	4.7	5×5.4	0.12	3	20	UWJ1H4R7MCL1GB
	10	6.3×5.4	0.12	5	33	UWJ1H100MCL1GB

• For taping specifications, recommended land size/soldering by reflow and minimum order quantity, please refer to the Guidelines for Aluminum Electrolytic Capacitors.

ALUMINUM ELECTROLYTIC CAPACITORS

UWP

5.5mmL Chip Type, Bi-Polarized



- Designed for surface mounting on high density PC board.
- Applicable to automatic mounting machine fed with carrier tape.
- Compliant to the RoHS directive (2011/65/EU,(EU)2015/863).
- AEC-Q200 compliant. Please contact us for details.

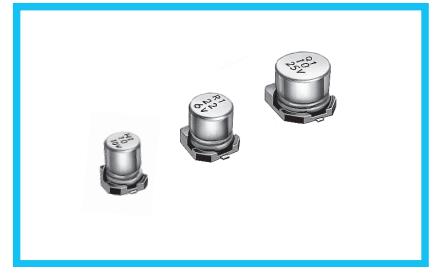

Specifications

Item	Performance Characteristics							
Category Temperature Range	-40 to +85°C							
Rated Voltage Range	6.3 to 50V							
Rated Capacitance Range	0.1 to 100μF							
Capacitance Tolerance	±20% at 120Hz, 20°C							
Leakage Current ※	After 2 minutes' application of rated voltage at 20°C, leakage current is not more than 0.05CV or 10 (μA) ,whichever is greater.							
Tangent of loss angle (tan δ)	Measurement frequency : 120Hz at 20°C							
	Rated voltage (V)	6.3	10	16	25	35	50	
Stability at Low Temperature	Measurement frequency : 120Hz							
	Rated voltage (V)		6.3	10	16	25	35	50
	Impedance ratio ZT / Z20 (max.)	Z(-25°C) / Z(+20°C)	4	3	2	2	2	2
Endurance	The specifications listed at right shall be met when the capacitors are restored to 20°C after the rated voltage is applied for 1000 hours at 85°C with the polarity inverted every 250 hours.							
	Capacitance change	Within ±20% of the initial capacitance value						
Shelf Life	After storing the capacitors under no load at 85°C for 1000 hours and then performing voltage treatment based on JIS C 5101-4 clause 4.1 at 20°C, they shall meet the specified values for the endurance characteristics listed above.							
	tan δ	200% or less than the initial specified value						
Resistance to soldering heat	The capacitors are kept on a hot plate for 30 seconds, which is maintained at 250°C. The capacitors shall meet the characteristic requirements listed at right when they are removed from the plate and restored to 20°C.							
	Leakage current	Less than or equal to the initial specified value						
Marking	Black print on the case top.							

※ I : Leakage Current (μA), C : Rated Capacitance (μF), V : Rated Voltage (V)

Chip Type

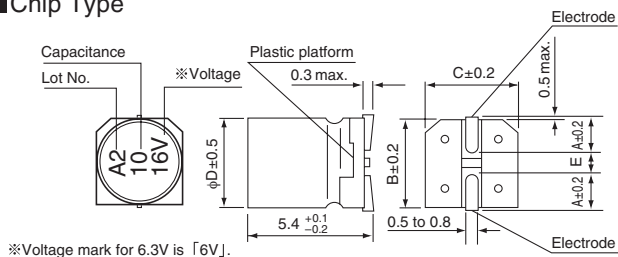

※Voltage mark for 6.3V is 「6V」.

	(mm)			
φD	4	5	6.3	8
A	1.8	2.1	2.4	3.3
B	4.3	5.3	6.6	8.3
C	4.3	5.3	6.6	8.3
E	1.0	1.3	2.2	2.3

Type numbering system (Example : 16V 10μF)

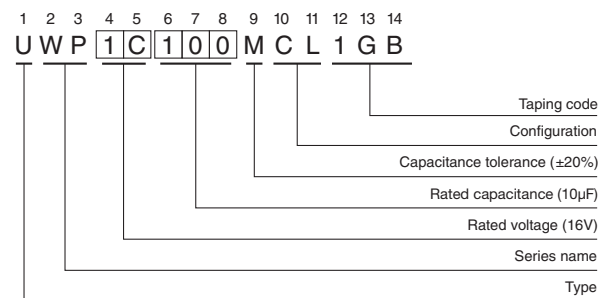

Frequency coefficient of rated ripple current

Frequency	50 Hz	120 Hz	300 Hz	1 kHz	10 kHz or more
Coefficient	0.70	1.00	1.17	1.36	1.50

●Dimension table in next page.

UWP

■ Dimensions

Rated Voltage (V) (code)	Rated Capacitance (μF)	Case Size φD×L (mm)	tan δ	Leakage Current (μA) (at 20°C after 2 minutes)	Rated Ripple (mArms) (85°C/120Hz)	Part Number
6.3 (0J)	22	5×5.4	0.24	10	28	UWP0J220MCL1GB
	33	6.3×5.4	0.24	10.395	37	UWP0J330MCL1GB
	47	6.3×5.4	0.24	14.805	45	UWP0J470MCL1GB
	100	8×5.4	0.24	31.5	82	UWP0J101MCL1GB
10 (1A)	10	4×5.4	0.20	10	17	UWP1A100MCL1GB
	22	6.3×5.4	0.20	11	33	UWP1A220MCL1GB
	33	6.3×5.4	0.20	16.5	41	UWP1A330MCL1GB
	47	8×5.4	0.20	23.5	61	UWP1A470MCL1GB
16 (1C)	4.7	4×5.4	0.17	10	12	UWP1C47MCL1GB
	10	5×5.4	0.17	10	23	UWP1C100MCL1GB
	22	6.3×5.4	0.17	17.6	37	UWP1C220MCL1GB
	33	6.3×5.4	0.17	26.4	49	UWP1C330MCL1GB
	47	8×5.4	0.17	37.6	75	UWP1C470MCL1GB
25 (1E)	3.3	5×5.4	0.17	10	12	UWP1E33MCL1GB
	4.7	5×5.4	0.17	10	16	UWP1E47MCL1GB
	10	6.3×5.4	0.17	12.5	27	UWP1E100MCL1GB
	22	8×5.4	0.17	27.5	50	UWP1E220MCL1GB
	33	8×5.4	0.17	41.25	61	UWP1E330MCL1GB
35 (1V)	2.2	4×5.4	0.15	10	8.4	UWP1V22MCL1GB
	3.3	5×5.4	0.15	10	16	UWP1V33MCL1GB
	4.7	5×5.4	0.15	10	18	UWP1V47MCL1GB
	10	6.3×5.4	0.15	17.5	29	UWP1V100MCL1GB
	22	8×5.4	0.15	38.5	54	UWP1V220MCL1GB
50 (1H)	0.1	4×5.4	0.15	10	1.0	UWP1H01MCL1GB
	0.22	4×5.4	0.15	10	2.0	UWP1HR22MCL1GB
	0.33	4×5.4	0.15	10	2.8	UWP1HR33MCL1GB
	0.47	4×5.4	0.15	10	4.0	UWP1HR47MCL1GB
	1	4×5.4	0.15	10	8.4	UWP1H010MCL1GB
	2.2	5×5.4	0.15	10	13	UWP1H22MCL1GB
	3.3	5×5.4	0.15	10	17	UWP1H33MCL1GB
	4.7	6.3×5.4	0.15	11.75	20	UWP1H47MCL1GB
	10	8×5.4	0.15	25	36	UWP1H100MCL1GB

- For taping specifications, recommended land size/soldering by reflow and minimum order quantity, please refer to the Guidelines for Aluminum Electrolytic Capacitors.
- Please select UUN if high C/V products are required.

ALUMINUM ELECTROLYTIC CAPACITORS

UWT Chip Type, Wide Temperature Range



- Chip type operating over wide temperature range of to -55 to $+105^{\circ}\text{C}$.
- Designed for surface mounting on high density PC board.
- Applicable to automatic mounting machine fed with carrier tape.
- Compliant to the RoHS directive (2011/65/EU, (EU)2015/863).
- AEC-Q200 compliant. Please contact us for details.

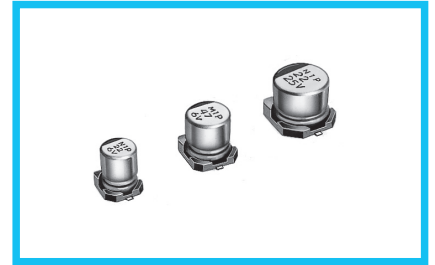
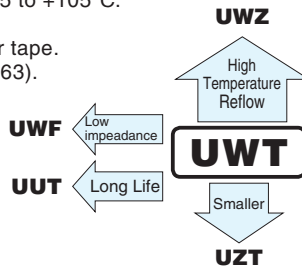

Specifications

Item	Performance Characteristics																								
Category Temperature Range	-55 to $+105^{\circ}\text{C}$																								
Rated Voltage Range	4 to 50V																								
Rated Capacitance Range	1 to 1500 μF																								
Capacitance Tolerance	$\pm 20\%$ at 120Hz, 20°C																								
Leakage Current ※	After 2 minutes' application of rated voltage at 20°C , leakage current is not more than 0.01CV or $3 (\mu\text{A})$, whichever is greater.																								
Tangent of loss angle (tan δ)	Measurement frequency : 120Hz at 20°C <table border="1"> <tr> <td>Rated voltage (V)</td> <td>4</td> <td>6.3</td> <td>10</td> <td>16</td> <td>25</td> <td>35</td> <td>50</td> </tr> <tr> <td>tan δ (max.)</td> <td>0.40</td> <td>0.30</td> <td>0.24</td> <td>0.20</td> <td>0.16</td> <td>0.14</td> <td>0.14</td> </tr> </table>	Rated voltage (V)	4	6.3	10	16	25	35	50	tan δ (max.)	0.40	0.30	0.24	0.20	0.16	0.14	0.14								
Rated voltage (V)	4	6.3	10	16	25	35	50																		
tan δ (max.)	0.40	0.30	0.24	0.20	0.16	0.14	0.14																		
Stability at Low Temperature	Measurement frequency : 120Hz <table border="1"> <tr> <td>Rated voltage (V)</td> <td>4</td> <td>6.3</td> <td>10</td> <td>16</td> <td>25</td> <td>35</td> <td>50</td> </tr> <tr> <td>Impedance ratio</td> <td>Z(-25°C) / Z($+20^{\circ}\text{C}$)</td> <td>7</td> <td>4</td> <td>3</td> <td>2</td> <td>2</td> <td>2</td> </tr> <tr> <td>ZT / Z20 (max.)</td> <td>Z(-40°C) / Z($+20^{\circ}\text{C}$)</td> <td>15</td> <td>8</td> <td>8</td> <td>4</td> <td>4</td> <td>3</td> </tr> </table>	Rated voltage (V)	4	6.3	10	16	25	35	50	Impedance ratio	Z(-25°C) / Z($+20^{\circ}\text{C}$)	7	4	3	2	2	2	ZT / Z20 (max.)	Z(-40°C) / Z($+20^{\circ}\text{C}$)	15	8	8	4	4	3
Rated voltage (V)	4	6.3	10	16	25	35	50																		
Impedance ratio	Z(-25°C) / Z($+20^{\circ}\text{C}$)	7	4	3	2	2	2																		
ZT / Z20 (max.)	Z(-40°C) / Z($+20^{\circ}\text{C}$)	15	8	8	4	4	3																		
Endurance	The specifications listed at right shall be met when the capacitors are restored to 20°C after the rated voltage is applied for 1000 hours at 105°C . <table border="1"> <tr> <td>Capacitance change</td> <td>Within $\pm 25\%$ of the initial capacitance value for capacitors of 16V or less. Within $\pm 20\%$ of the initial capacitance value for capacitors of 25V or more.</td> </tr> <tr> <td>tan δ</td> <td>200% or less than the initial specified value</td> </tr> <tr> <td>Leakage current</td> <td>Less than or equal to the initial specified value</td> </tr> </table>	Capacitance change	Within $\pm 25\%$ of the initial capacitance value for capacitors of 16V or less. Within $\pm 20\%$ of the initial capacitance value for capacitors of 25V or more.	tan δ	200% or less than the initial specified value	Leakage current	Less than or equal to the initial specified value																		
Capacitance change	Within $\pm 25\%$ of the initial capacitance value for capacitors of 16V or less. Within $\pm 20\%$ of the initial capacitance value for capacitors of 25V or more.																								
tan δ	200% or less than the initial specified value																								
Leakage current	Less than or equal to the initial specified value																								
Shelf Life	After storing the capacitors under no load at 105°C for 1000 hours and then performing voltage treatment based on JIS C 5101-4 clause 4.1 at 20°C , they shall meet the specified values for the endurance characteristics listed above.																								
Resistance to soldering heat	The capacitors are kept on a hot plate for 30 seconds, which is maintained at 250°C . The capacitors shall meet the characteristic requirements listed at right when they are removed from the plate and restored to 20°C . <table border="1"> <tr> <td>Capacitance change</td> <td>Within $\pm 10\%$ of the initial capacitance value</td> </tr> <tr> <td>tan δ</td> <td>Less than or equal to the initial specified value</td> </tr> <tr> <td>Leakage current</td> <td>Less than or equal to the initial specified value</td> </tr> </table>	Capacitance change	Within $\pm 10\%$ of the initial capacitance value	tan δ	Less than or equal to the initial specified value	Leakage current	Less than or equal to the initial specified value																		
Capacitance change	Within $\pm 10\%$ of the initial capacitance value																								
tan δ	Less than or equal to the initial specified value																								
Leakage current	Less than or equal to the initial specified value																								
Marking	Black print on the case top.																								

※ I : Leakage Current (μA), C : Rated Capacitance (μF), V : Rated Voltage (V)

Chip Type

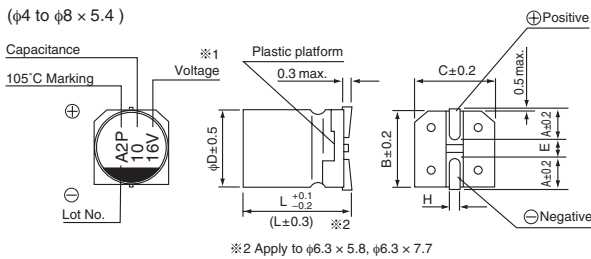

※2 Apply to $\phi 6.3 \times 5.8$, $\phi 6.3 \times 7.7$

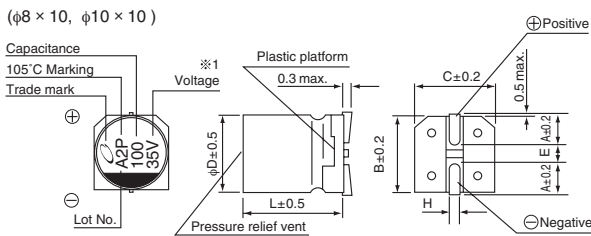

※1. Voltage mark for 6.3V is 「6V」.

Type numbering system (Example : 16V 10 μF)

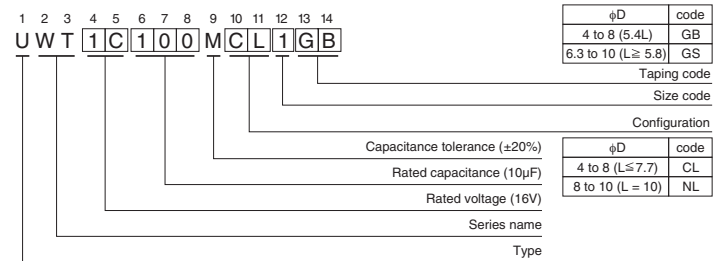

	(mm)							
φD × L	4 × 5.4	5 × 5.4	6.3 × 5.4	6.3 × 5.8	6.3 × 7.7	8 × 5.4	8 × 10	10 × 10
A	1.8	2.1	2.4	2.4	2.4	3.3	2.9	3.2
B	4.3	5.3	6.6	6.6	6.6	8.3	8.3	10.3
C	4.3	5.3	6.6	6.6	6.6	8.3	8.3	10.3
E	1.0	1.3	2.2	2.2	2.2	2.3	3.1	4.5
L	5.4	5.4	5.4	5.8	7.7	5.4	10	10
H	0.5 to 0.8	0.5 to 0.8	0.5 to 0.8	0.5 to 0.8	0.5 to 0.8	0.5 to 0.8	0.8 to 1.1	0.8 to 1.1

Frequency coefficient of rated ripple current

Frequency	50 Hz	120 Hz	300 Hz	1 kHz	10 kHz or more
Coefficient	0.70	1.00	1.17	1.36	1.50

● Dimension table in next page.

UWT

■ Dimensions

Rated Voltage (V) (code)	Rated Capacitance (μF)	Case Size φD×L (mm)	tan δ	Leakage Current (μA) (at 20°C after 2 minutes)	Rated Ripple (mArms) (105°C/120Hz)	Part Number
4 (0G)	22	4×5.4	0.40	3	22	UWT0G220MCL1GB
	33	5×5.4	0.40	3	30	UWT0G330MCL1GB
	47	5×5.4	0.40	3	36	UWT0G470MCL1GB
	100	6.3×5.4	0.40	4	60	UWT0G101MCL1GB
	150	6.3×5.8	0.40	6	86	UWT0G151MCL1GS
	220	8×5.4	0.40	8.8	102	UWT0G221MCL1GB
	220	6.3×5.8	0.40	8.8	91	UWT0G221MCL6GS
	330	6.3×7.7	0.40	13.2	105	UWT0G331MCL1GS
	470	8×10	0.40	18.8	210	UWT0G471MNL1GS
	680	8×10	0.40	27.2	210	UWT0G681MNL1GS
	1000	8×10	0.40	40	230	UWT0G102MNL1GS
1500	10×10	0.40	60	310	UWT0G152MNL1GS	
6.3 (0J)	22	4×5.4	0.30	3	22	UWT0J220MCL1GB
	33	5×5.4	0.30	3	30	UWT0J330MCL1GB
	47	5×5.4	0.30	3	36	UWT0J470MCL1GB
	100	6.3×5.4	0.30	6.3	60	UWT0J101MCL1GB
	150	6.3×5.8	0.30	9.45	86	UWT0J151MCL1GS
	220	8×5.4	0.30	13.86	102	UWT0J221MCL1GB
	220	6.3×5.8	0.30	13.86	91	UWT0J221MCL6GS
	330	6.3×7.7	0.30	20.79	105	UWT0J331MCL1GS
	470	8×10	0.30	29.61	210	UWT0J471MNL1GS
	680	8×10	0.30	42.84	210	UWT0J681MNL1GS
	1000	8×10	0.30	63	230	UWT0J102MNL1GS
1500	10×10	0.30	94.5	310	UWT0J152MNL1GS	
10 (1A)	22	5×5.4	0.24	3	27	UWT1A220MCL1GB
	33	5×5.4	0.24	3.3	35	UWT1A330MCL1GB
	47	6.3×5.4	0.24	4.7	46	UWT1A470MCL1GB
	100	6.3×5.4	0.24	10	60	UWT1A101MCL1GB
	150	6.3×5.8	0.24	15	86	UWT1A151MCL1GS
	220	6.3×7.7	0.24	22	105	UWT1A221MCL1GS
	330	8×10	0.24	33	195	UWT1A331MNL1GS
	470	8×10	0.24	47	210	UWT1A471MNL1GS
	680	10×10	0.24	68	310	UWT1A681MNL1GS
1000	10×10	0.24	100	310	UWT1A102MNL1GS	
16 (1C)	10	4×5.4	0.20	3	18	UWT1C100MCL1GB
	22	5×5.4	0.20	3.52	30	UWT1C220MCL1GB
	33	6.3×5.4	0.20	5.28	40	UWT1C330MCL1GB
	47	6.3×5.4	0.20	7.52	50	UWT1C470MCL1GB
	100	6.3×5.4	0.20	16	60	UWT1C101MCL1GB
	150	6.3×7.7	0.20	24	95	UWT1C151MCL1GS
	220	6.3×7.7	0.20	35.2	105	UWT1C221MCL1GS
	330	8×10	0.20	52.8	195	UWT1C331MNL1GS
	470	8×10	0.20	75.2	230	UWT1C471MNL1GS
680	10×10	0.20	108.8	310	UWT1C681MNL1GS	

UWT

■ Dimensions

Rated Voltage (V) (code)	Rated Capacitance (μF)	Case Size φD×L (mm)	tan δ	Leakage Current (μA) (at 20°C after 2 minutes)	Rated Ripple (mArms) (105°C/120Hz)	Part Number
25 (1E)	4.7	4×5.4	0.16	3	13	UWT1E4R7MCL1GB
	10	5×5.4	0.16	3	23	UWT1E100MCL1GB
	22	6.3×5.4	0.16	5.5	38	UWT1E220MCL1GB
	33	6.3×5.4	0.16	8.25	48	UWT1E330MCL1GB
	47	8×5.4	0.16	11.75	66	UWT1E470MCL1GB
	47	6.3×5.8	0.16	11.75	59	UWT1E470MCL6GS
	100	6.3×7.7	0.16	25	91	UWT1E101MCL1GS
	150	8×10	0.16	37.5	140	UWT1E151MNL1GS
	220	8×10	0.16	55	155	UWT1E221MNL1GS
	330	8×10	0.16	82.5	190	UWT1E331MNL1GS
470	10×10	0.16	117.5	300	UWT1E471MNL1GS	
35 (1V)	4.7	4×5.4	0.14	3	15	UWT1V4R7MCL1GB
	10	5×5.4	0.14	3.5	25	UWT1V100MCL1GB
	22	6.3×5.4	0.14	7.7	42	UWT1V220MCL1GB
	33	8×5.4	0.14	11.55	59	UWT1V330MCL1GB
	33	6.3×5.8	0.14	11.55	52	UWT1V330MCL6GS
	47	6.3×5.8	0.14	16.45	63	UWT1V470MCL1GS
	100	6.3×7.7	0.14	35	84	UWT1V101MCL1GS
	150	8×10	0.14	52.5	155	UWT1V151MNL1GS
	220	8×10	0.14	77	190	UWT1V221MNL1GS
	330	10×10	0.14	115.5	300	UWT1V331MNL1GS
50 (1H)	1	4×5.4	0.14	3	6.2	UWT1H010MCL1GB
	2.2	4×5.4	0.14	3	11	UWT1H2R2MCL1GB
	3.3	4×5.4	0.14	3	14	UWT1H3R3MCL1GB
	4.7	5×5.4	0.14	3	19	UWT1H4R7MCL1GB
	10	6.3×5.4	0.14	5	30	UWT1H100MCL1GB
	22	8×5.4	0.14	11	51	UWT1H220MCL1GB
	22	6.3×5.8	0.14	11	45	UWT1H220MCL6GS
	33	6.3×7.7	0.14	16.5	60	UWT1H330MCL1GS
	47	6.3×7.7	0.14	23.5	63	UWT1H470MCL1GS
	100	8×10	0.14	50	140	UWT1H101MNL1GS
	150	10×10	0.14	75	180	UWT1H151MNL1GS
	220	10×10	0.14	110	220	UWT1H221MNL1GS

- For taping specifications, recommended land size/soldering by reflow and minimum order quantity, please refer to the Guidelines for Aluminum Electrolytic Capacitors.
- Please select UUX, UUU series if high C/V products are required.

ALUMINUM ELECTROLYTIC CAPACITORS

UWZ

Chip Type, Wide Temperature Range
High Temperature (260°C) Reflow



UWZ

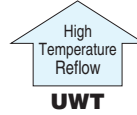

- Corresponding with 260°C peak reflow soldering
Recommended reflow condition : 260°C peak 5 sec 230°C over 60 sec 2 times
(φ8 × 6.2, φ10 × 10 : 1 time)
- Chip type operating over wide temperature range of to -55 to +105°C.
- Applicable to automatic mounting machine fed with carrier tape.
- Compliant to the RoHS directive (2011/65/EU, (EU)2015/863).
- AEC-Q200 compliant. Please contact us for details.

Specifications

Item	Performance Characteristics																							
Category Temperature Range	-55 to +105°C																							
Rated Voltage Range	6.3 to 50V																							
Rated Capacitance Range	1 to 1500μF																							
Capacitance Tolerance	±20% at 120Hz, 20°C																							
Leakage Current ※	After 2 minutes' application of rated voltage at 20°C, leakage current is not more than 0.01CV or 3 (μA) , whichever is greater.																							
Tangent of loss angle (tan δ)	Measurement frequency : 120Hz at 20°C																							
	<table border="1"> <tr> <td>Rated voltage (V)</td> <td>6.3</td> <td>10</td> <td>16</td> <td>25</td> <td>35</td> <td>50</td> </tr> <tr> <td>tan δ (max.)</td> <td>0.30</td> <td>0.24</td> <td>0.20</td> <td>0.16</td> <td>0.14</td> <td>0.14</td> </tr> </table>	Rated voltage (V)	6.3	10	16	25	35	50	tan δ (max.)	0.30	0.24	0.20	0.16	0.14	0.14									
Rated voltage (V)	6.3	10	16	25	35	50																		
tan δ (max.)	0.30	0.24	0.20	0.16	0.14	0.14																		
Stability at Low Temperature	Measurement frequency : 120Hz																							
	<table border="1"> <tr> <td colspan="2">Rated voltage (V)</td> <td>6.3</td> <td>10</td> <td>16</td> <td>25</td> <td>35</td> <td>50</td> </tr> <tr> <td>Impedance ratio</td> <td>Z(-25°C) / Z(+20°C)</td> <td>4</td> <td>3</td> <td>2</td> <td>2</td> <td>2</td> <td>2</td> </tr> <tr> <td>ZT / Z20 (max.)</td> <td>Z(-40°C) / Z(+20°C)</td> <td>8</td> <td>8</td> <td>4</td> <td>4</td> <td>3</td> <td>3</td> </tr> </table>	Rated voltage (V)		6.3	10	16	25	35	50	Impedance ratio	Z(-25°C) / Z(+20°C)	4	3	2	2	2	2	ZT / Z20 (max.)	Z(-40°C) / Z(+20°C)	8	8	4	4	3
Rated voltage (V)		6.3	10	16	25	35	50																	
Impedance ratio	Z(-25°C) / Z(+20°C)	4	3	2	2	2	2																	
ZT / Z20 (max.)	Z(-40°C) / Z(+20°C)	8	8	4	4	3	3																	
Endurance	<p>The specifications listed at right shall be met when the capacitors are restored to 20°C after the rated voltage is applied for 1000 hours at 105°C.</p> <table border="1"> <tr> <td>Capacitance change</td> <td>Within ±25% of the initial capacitance value for capacitors of 16V or less. Within ±20% of the initial capacitance value for capacitors of 25V or more.</td> </tr> <tr> <td>tan δ</td> <td>200% or less than the initial specified value</td> </tr> <tr> <td>Leakage current</td> <td>Less than or equal to the initial specified value</td> </tr> </table>	Capacitance change	Within ±25% of the initial capacitance value for capacitors of 16V or less. Within ±20% of the initial capacitance value for capacitors of 25V or more.	tan δ	200% or less than the initial specified value	Leakage current	Less than or equal to the initial specified value																	
Capacitance change	Within ±25% of the initial capacitance value for capacitors of 16V or less. Within ±20% of the initial capacitance value for capacitors of 25V or more.																							
tan δ	200% or less than the initial specified value																							
Leakage current	Less than or equal to the initial specified value																							
Shelf Life	After storing the capacitors under no load at 105°C for 1000 hours and then performing voltage treatment based on JIS C 5101-4 clause 4.1 at 20°C, they shall meet the specified values for the endurance characteristics listed above.																							
Resistance to soldering heat	<p>The capacitors are kept on a hot plate for 30 seconds, which is maintained at 250°C. The capacitors shall meet the characteristic requirements listed at right when they are removed from the plate and restored to 20°C.</p> <table border="1"> <tr> <td>Capacitance change</td> <td>Within ±10% of the initial capacitance value</td> </tr> <tr> <td>tan δ</td> <td>Less than or equal to the initial specified value</td> </tr> <tr> <td>Leakage current</td> <td>Less than or equal to the initial specified value</td> </tr> </table>	Capacitance change	Within ±10% of the initial capacitance value	tan δ	Less than or equal to the initial specified value	Leakage current	Less than or equal to the initial specified value																	
Capacitance change	Within ±10% of the initial capacitance value																							
tan δ	Less than or equal to the initial specified value																							
Leakage current	Less than or equal to the initial specified value																							
Marking	Black print on the case top.																							

※ I : Leakage Current (μA), C : Rated Capacitance (μF), V : Rated Voltage (V)

Chip Type

(φ4 to φ6.3)

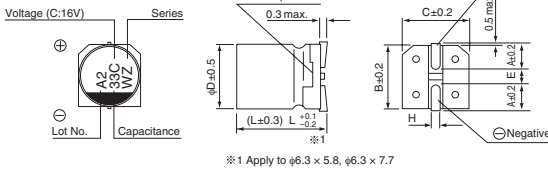

(φ8 × 6.2)

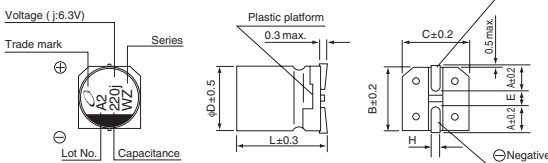

(φ8 × 10, φ10 × 10)

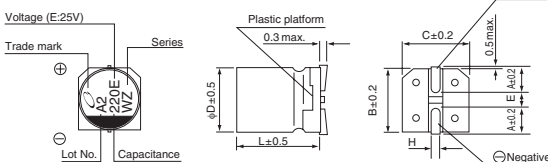

Type numbering system (Example : 6.3V 33μF)

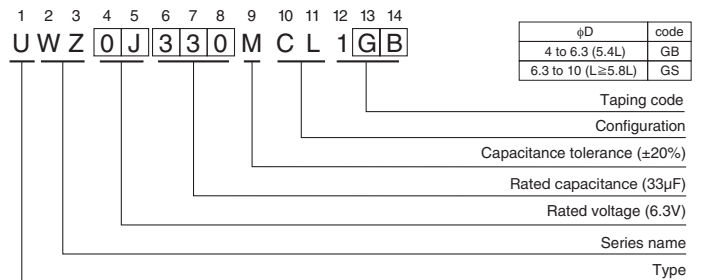

φD × L	(mm)							
	4 × 5.4	5 × 5.4	6.3 × 5.4	6.3 × 5.8	6.3 × 7.7	8 × 6.2	8 × 10	10 × 10
A	1.8	2.1	2.4	2.4	2.4	3.3	2.9	3.2
B	4.3	5.3	6.6	6.6	6.6	8.3	8.3	10.3
C	4.3	5.3	6.6	6.6	6.6	8.3	8.3	10.3
E	1.0	1.3	2.2	2.2	2.2	2.3	3.1	4.5
L	5.4	5.4	5.4	5.8	7.7	6.2	10	10
H	0.5 to 0.8	0.5 to 0.8	0.5 to 0.8	0.5 to 0.8	0.5 to 0.8	0.5 to 0.8	0.8 to 1.1	0.8 to 1.1

Voltage

V	6.3	10	16	25	35	50
Code	j	A	C	E	V	H

● Frequency coefficient of rated ripple current

Frequency	50 Hz	120 Hz	300 Hz	1 kHz	10 kHz or more
Coefficient	0.70	1.00	1.17	1.36	1.50

● Dimension table in next page.

UWZ

■ Dimensions

Rated Voltage (V) (code)	Rated Capacitance (μF)	Case Size φD×L (mm)	tan δ	Leakage Current (μA) (at 20°C after 2 minutes)	Rated Ripple (mArms) (105°C/120Hz)	Part Number
6.3 (0J)	22	4×5.4	0.30	3	22	UWZ0J220MCL1GB
	33	5×5.4	0.30	3	30	UWZ0J330MCL1GB
	47	5×5.4	0.30	3	36	UWZ0J470MCL1GB
	100	6.3×5.4	0.30	6.3	60	UWZ0J101MCL1GB
	150	6.3×5.8	0.30	9.45	86	UWZ0J151MCL1GS
	220	8×6.2	0.30	13.86	102	UWZ0J221MCL1GS
	330	6.3×7.7	0.30	20.79	105	UWZ0J331MCL1GS
	470	8×10	0.30	29.61	210	UWZ0J471MCL1GS
	680	8×10	0.30	42.84	210	UWZ0J681MCL1GS
	1000	10×10	0.30	63	230	UWZ0J102MCL1GS
	1500	10×10	0.30	94.5	310	UWZ0J152MCL1GS
10 (1A)	22	5×5.4	0.24	3	27	UWZ1A220MCL1GB
	33	5×5.4	0.24	3.3	35	UWZ1A330MCL1GB
	47	6.3×5.4	0.24	4.7	46	UWZ1A470MCL1GB
	100	6.3×5.4	0.24	10	60	UWZ1A101MCL1GB
	150	6.3×5.8	0.24	15	86	UWZ1A151MCL1GS
	220	6.3×7.7	0.24	22	105	UWZ1A221MCL1GS
	330	8×10	0.24	33	195	UWZ1A331MCL1GS
	470	8×10	0.24	47	210	UWZ1A471MCL1GS
	680	10×10	0.24	68	310	UWZ1A681MCL1GS
	1000	10×10	0.24	100	310	UWZ1A102MCL1GS
16 (1C)	10	4×5.4	0.20	3	18	UWZ1C100MCL1GB
	22	5×5.4	0.20	3.52	30	UWZ1C220MCL1GB
	33	6.3×5.4	0.20	5.28	40	UWZ1C330MCL1GB
	47	6.3×5.4	0.20	7.52	50	UWZ1C470MCL1GB
	100	6.3×5.4	0.20	16	60	UWZ1C101MCL1GB
	150	6.3×7.7	0.20	24	95	UWZ1C151MCL1GS
	220	6.3×7.7	0.20	35.2	105	UWZ1C221MCL1GS
	330	8×10	0.20	52.8	195	UWZ1C331MCL1GS
	470	8×10	0.20	75.2	210	UWZ1C471MCL1GS
	680	10×10	0.20	108.8	310	UWZ1C681MCL1GS
25 (1E)	4.7	4×5.4	0.16	3	13	UWZ1E47MCL1GB
	10	5×5.4	0.16	3	23	UWZ1E100MCL1GB
	22	6.3×5.4	0.16	5.5	38	UWZ1E220MCL1GB
	33	6.3×5.4	0.16	8.25	48	UWZ1E330MCL1GB
	47	8×6.2	0.16	11.75	66	UWZ1E470MCL1GS
	100	6.3×7.7	0.16	25	91	UWZ1E101MCL1GS
	150	8×10	0.16	37.5	140	UWZ1E151MCL1GS
	220	8×10	0.16	55	155	UWZ1E221MCL1GS
	330	10×10	0.16	82.5	190	UWZ1E331MCL1GS
	470	10×10	0.16	117.5	300	UWZ1E471MCL1GS

UWZ

■ Dimensions

Rated Voltage (V) (code)	Rated Capacitance (μ F)	Case Size ϕ D \times L (mm)	$\tan \delta$	Leakage Current (μ A) (at 20°C after 2 minutes)	Rated Ripple (mArms) (105°C/120Hz)	Part Number
35 (1V)	4.7	4 \times 5.4	0.14	3	15	UWZ1V4R7MCL1GB
	10	5 \times 5.4	0.14	3.5	25	UWZ1V100MCL1GB
	22	6.3 \times 5.4	0.14	7.7	42	UWZ1V220MCL1GB
	33	8 \times 6.2	0.14	11.55	59	UWZ1V330MCL1GS
	47	6.3 \times 5.8	0.14	16.45	63	UWZ1V470MCL1GS
	100	6.3 \times 7.7	0.14	35	84	UWZ1V101MCL1GS
	150	8 \times 10	0.14	52.5	155	UWZ1V151MCL1GS
	220	10 \times 10	0.14	77	190	UWZ1V221MCL1GS
	330	10 \times 10	0.14	115.5	300	UWZ1V331MCL1GS
50 (1H)	1	4 \times 5.4	0.14	3	6.3	UWZ1H010MCL1GB
	2.2	4 \times 5.4	0.14	3	11	UWZ1H2R2MCL1GB
	3.3	4 \times 5.4	0.14	3	14	UWZ1H3R3MCL1GB
	4.7	5 \times 5.4	0.14	3	19	UWZ1H4R7MCL1GB
	10	6.3 \times 5.4	0.14	5	30	UWZ1H100MCL1GB
	22	8 \times 6.2	0.14	11	51	UWZ1H220MCL1GS
	33	6.3 \times 7.7	0.14	16.5	60	UWZ1H330MCL1GS
	47	6.3 \times 7.7	0.14	23.5	63	UWZ1H470MCL1GS
	100	8 \times 10	0.14	50	140	UWZ1H101MCL1GS
	150	10 \times 10	0.14	75	180	UWZ1H151MCL1GS
	220	10 \times 10	0.14	110	220	UWZ1H221MCL1GS

- For taping specifications, recommended land size/soldering by reflow and minimum order quantity, please refer to the Guidelines for Aluminum Electrolytic Capacitors.

ALUMINUM ELECTROLYTIC CAPACITORS

UWF Chip Type, Low Impedance

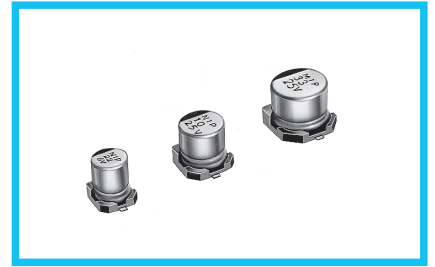

- Chip type, low impedance temperature range up to +105°C.
- Designed for surface mounting on high density PC board.
- Applicable to automatic mounting machine fed with carrier tape.
- Compliant to the RoHS directive (2011/65/EU, (EU)2015/863).
- AEC-Q200 compliant. Please contact us for details.

Products which are scheduled to be discontinued.
Not recommended for new designs.



Specifications

Item	Performance Characteristics						
Category Temperature Range	-55 to +105°C						
Rated Voltage Range	6.3 to 35V						
Rated Capacitance Range	1 to 220μF						
Capacitance Tolerance	±20% at 120Hz, 20°C						
Leakage Current ※	After 2 minutes' application of rated voltage at 20°C, leakage current is not more than 0.01CV or 3 (μA), whichever is greater.						
Tangent of loss angle (tan δ)	Measurement frequency : 120Hz at 20°C						
	Rated voltage (V)	6.3	10	16	25	35	
	tan δ (max.)	0.22	0.19	0.16	0.14	0.12	
Stability at Low Temperature	Measurement frequency : 120Hz						
	Rated voltage (V)	6.3	10	16	25	35	
	Impedance ratio Z(-25°C) / Z(+20°C)	2	2	2	2	2	
	ZT / Z20 (max.)	Z(-55°C) / Z(+20°C)	4	4	3	3	3
Endurance	The specifications listed at right shall be met when the capacitors are stored at 20°C after the rated voltage is applied for 1000 hours at 105°C.						
	Capacitance change	Within ±20% of the initial capacitance value					
	tan δ	200% or less than the initial specified value					
	Leakage current	Less than or equal to the initial specified value					
Shelf Life	After storing the capacitors under no load at 105°C for 1000 hours and then performing voltage treatment based on JIS C 5101-4 clause 4.1 at 20°C, they shall meet the specified values for the endurance characteristics listed above.						
Resistance to soldering heat	The capacitors are kept on a hot plate for 30 seconds, which is maintained at 250°C. The capacitors shall meet the characteristic requirements listed at right when they are removed from the plate and restored to 20°C.						
	Capacitance change	Within ±10% of the initial capacitance value					
	tan δ	Less than or equal to the initial specified value					
	Leakage current	Less than or equal to the initial specified value					
Marking	Black print on the case top.						

※ I : Leakage Current (μA), C : Rated Capacitance (μF), V : Rated Voltage (V)

Chip Type

(φ4 to φ6.3)

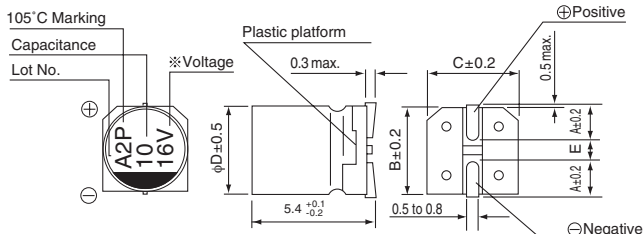

(φ8)

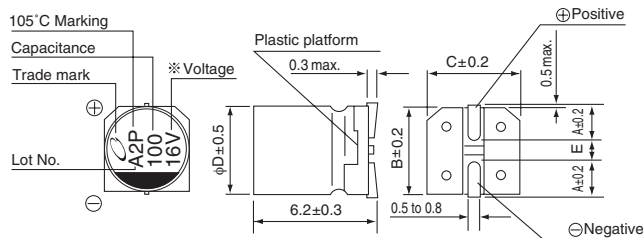

※ Voltage mark for 6.3V is 6V.

φD	4	5	6.3	8
A	1.8	2.1	2.4	3.3
B	4.3	5.3	6.6	8.3
C	4.3	5.3	6.6	8.3
E	1.0	1.3	2.2	2.3

Frequency coefficient of rated ripple current

Frequency	50 Hz	120 Hz	300 Hz	1 kHz	10 kHz or more
Coefficient	0.35	0.50	0.64	0.83	1.00

● Dimension table in next page.

Type numbering system (Example : 16V 10μF)

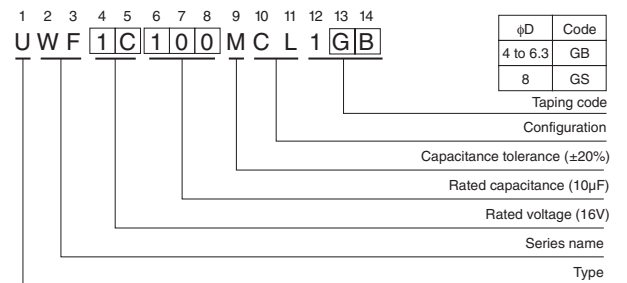

UWF

■ Dimensions

Rated Voltage (V) (code)	Rated Capacitance (μF)	Case Size φD×L (mm)	tan δ	Leakage Current (μA) (at 20°C after 2 minutes)	Impedance (Ω) max. (20°C/100kHz)	Rated Ripple (mA rms) (105°C/100kHz)	Part Number
6.3 (0J)	22	4×5.4	0.22	3	5.0	50	UWF0J220MCL1GB
	33	5×5.4	0.22	3	2.6	80	UWF0J330MCL1GB
	47	5×5.4	0.22	3	2.6	80	UWF0J470MCL1GB
	68	6.3×5.4	0.22	4.284	1.3	115	UWF0J680MCL1GB
	100	6.3×5.4	0.22	6.3	1.3	115	UWF0J101MCL1GB
	150	8×6.2	0.22	9.45	0.8	150	UWF0J151MCL1GS
	220	8×6.2	0.22	13.86	0.8	150	UWF0J221MCL1GS
10 (1A)	22	5×5.4	0.19	3	2.6	80	UWF1A220MCL1GB
	33	5×5.4	0.19	3.3	2.6	80	UWF1A330MCL1GB
	47	6.3×5.4	0.19	4.7	1.3	115	UWF1A470MCL1GB
	68	6.3×5.4	0.19	6.8	1.3	115	UWF1A680MCL1GB
	100	8×6.2	0.19	10	0.8	150	UWF1A101MCL1GS
	150	8×6.2	0.19	15	0.8	150	UWF1A151MCL1GS
16 (1C)	10	4×5.4	0.16	3	5.0	50	UWF1C100MCL1GB
	15	5×5.4	0.16	3	2.6	80	UWF1C150MCL1GB
	22	5×5.4	0.16	3.52	2.6	80	UWF1C220MCL1GB
	33	6.3×5.4	0.16	5.28	1.3	115	UWF1C330MCL1GB
	47	6.3×5.4	0.16	7.52	1.3	115	UWF1C470MCL1GB
	68	8×6.2	0.16	10.88	0.8	150	UWF1C680MCL1GS
	100	8×6.2	0.16	16	0.8	150	UWF1C101MCL1GS
25 (1E)	4.7	4×5.4	0.14	3	5.0	50	UWF1E4R7MCL1GB
	6.8	4×5.4	0.14	3	5.0	50	UWF1E6R8MCL1GB
	10	5×5.4	0.14	3	2.6	80	UWF1E100MCL1GB
	15	6.3×5.4	0.14	3.75	1.3	115	UWF1E150MCL1GB
	22	6.3×5.4	0.14	5.5	1.3	115	UWF1E220MCL1GB
	33	6.3×5.4	0.14	8.25	1.3	115	UWF1E330MCL1GB
	47	8×6.2	0.14	11.75	0.8	150	UWF1E470MCL1GS
	68	8×6.2	0.14	17	0.8	150	UWF1E680MCL1GS
35 (1V)	1	4×5.4	0.12	3	5.0	50	UWF1V010MCL1GB
	1.5	4×5.4	0.12	3	5.0	50	UWF1V1R5MCL1GB
	2.2	4×5.4	0.12	3	5.0	50	UWF1V2R2MCL1GB
	3.3	4×5.4	0.12	3	5.0	50	UWF1V3R3MCL1GB
	4.7	4×5.4	0.12	3	5.0	50	UWF1V4R7MCL1GB
	6.8	5×5.4	0.12	3	2.6	80	UWF1V6R8MCL1GB
	10	5×5.4	0.12	3.5	2.6	80	UWF1V100MCL1GB
	15	6.3×5.4	0.12	5.25	1.3	115	UWF1V150MCL1GB
	22	6.3×5.4	0.12	7.7	1.3	115	UWF1V220MCL1GB
	33	8×6.2	0.12	11.55	0.8	150	UWF1V330MCL1GS
	47	8×6.2	0.12	16.45	0.8	150	UWF1V470MCL1GS

- For taping specifications, recommended land size/soldering by reflow and minimum order quantity, please refer to the Guidelines for Aluminum Electrolytic Capacitors.
- Please select UUU if high C/V products are required.

ALUMINUM ELECTROLYTIC CAPACITORS

UWG

Chip Type, Low Impedance



- Chip type, operating over wide temperature range of to -55 to $+105^{\circ}\text{C}$.
- Designed for surface mounting on high density PC board.
- Applicable to automatic mounting machine fed with carrier tape.
- Compliant to the RoHS directive (2011/65/EU, (EU)2015/863).
- AEC-Q200 compliant. Please contact us for details.

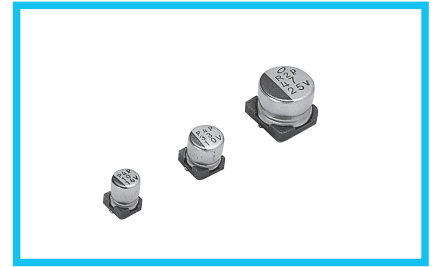

Specifications

Item	Performance Characteristics							
Category Temperature Range	-55 to $+105^{\circ}\text{C}$							
Rated Voltage Range	6.3 to 50V							
Rated Capacitance Range	1 to $1500\mu\text{F}$							
Capacitance Tolerance	$\pm 20\%$ at 120Hz, 20°C							
Leakage Current ※	After 2 minutes' application of rated voltage at 20°C , leakage current is not more than 0.01CV or $3(\mu\text{A})$, whichever is greater.							
Tangent of loss angle (tan δ)	Measurement frequency : 120Hz at 20°C							
	Rated voltage (V)	6.3	10	16	25	35	50	
Stability at Low Temperature	Measurement frequency : 120Hz							
	Rated voltage (V)		6.3	10	16	25	35	50
	Impedance ratio	$Z(-25^{\circ}\text{C}) / Z(+20^{\circ}\text{C})$	2	2	2	2	2	2
Endurance	The specifications listed at right shall be met when the capacitors are restored to 20°C after the rated voltage is applied for 1000 hours at 105°C .		Capacitance change				Within $\pm 20\%$ of the initial capacitance value	
			tan δ				200% or less than the initial specified value	
Shelf Life	After storing the capacitors under no load at 105°C for 1000 hours and then performing voltage treatment based on JIS C 5101-4 clause 4.1 at 20°C , they shall meet the specified values for the endurance characteristics listed above.		Leakage current				Less than or equal to the initial specified value	
			Capacitance change				Within $\pm 10\%$ of the initial capacitance value	
Resistance to soldering heat	The capacitors are kept on a hot plate for 30 seconds, which is maintained at 250°C . The capacitors shall meet the characteristic requirements listed at right when they are removed from the plate and restored to 20°C .		tan δ				Less than or equal to the initial specified value	
			Leakage current				Less than or equal to the initial specified value	
Marking	Black print on the case top.							

※ I : Leakage Current (μA), C : Rated Capacitance (μF), V : Rated Voltage (V)

Chip Type

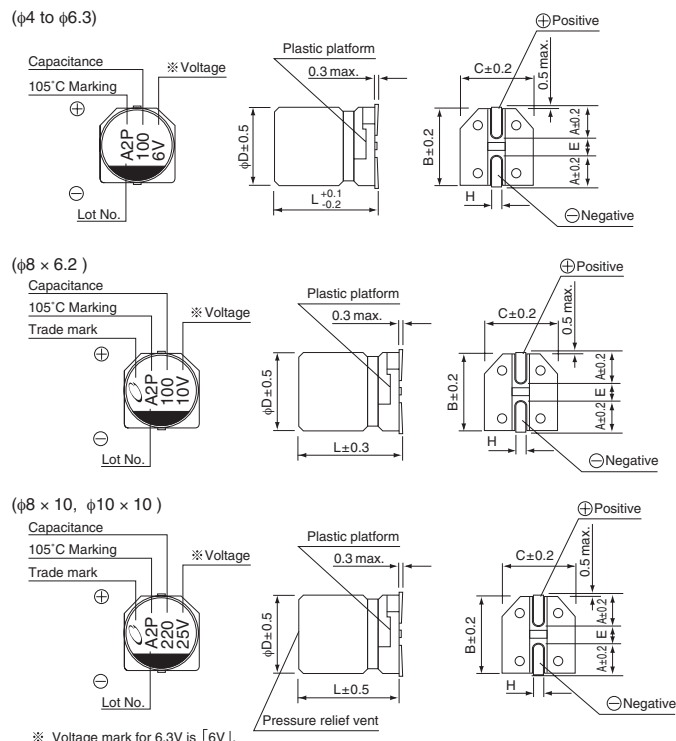

Type numbering system (Example : 10V 100 μF)

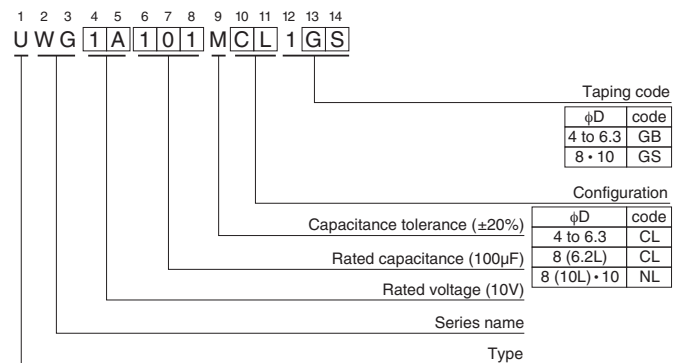

$\phi\text{D} \times \text{L}$	4 × 5.4	5 × 5.4	6.3 × 5.4	8 × 6.2	8 × 10	10 × 10
A	1.8	2.1	2.4	3.3	2.9	3.2
B	4.3	5.3	6.6	8.3	8.3	10.3
C	4.3	5.3	6.6	8.3	8.3	10.3
E	1.0	1.3	2.2	2.3	3.1	4.5
L	5.4	5.4	5.4	6.2	10	10
H	0.5 to 0.8	0.5 to 0.8	0.5 to 0.8	0.5 to 0.8	0.8 to 1.1	0.8 to 1.1

Frequency coefficient of rated ripple current

Frequency	50 Hz	120 Hz	300 Hz	1 kHz	10 kHz or more
Coefficient	0.35	0.50	0.64	0.83	1.00

● Dimension table in next page.



■ Dimensions

Rated Voltage (V) (code)	Rated Capacitance (μF)	Case Size φD×L (mm)	tan δ	Leakage Current (μA) (at 20°C after 2 minutes)	Impedance (Ω) max. (20°C/100kHz)	Rated Ripple (mArms) (105°C/100kHz)	Part Number
6.3 (0J)	22	4×5.4	0.26	3	3.00	60	UWG0J220MCL1GB
	47	5×5.4	0.26	3	1.80	95	UWG0J470MCL1GB
	68	6.3×5.4	0.26	4.284	1.00	140	UWG0J680MCL1GB
	100	6.3×5.4	0.26	6.3	1.00	140	UWG0J101MCL1GB
	220	8×6.2	0.26	13.86	0.40	230	UWG0J221MCL1GS
	330	8×10	0.26	20.79	0.30	450	UWG0J331MNL1GS
	1000	10×10	0.26	63	0.15	670	UWG0J102MNL1GS
	1500	10×10	0.26	94.5	0.15	670	UWG0J152MNL1GS
10 (1A)	33	5×5.4	0.19	3.3	1.80	95	UWG1A330MCL1GB
	100	8×6.2	0.19	10	0.40	230	UWG1A101MCL1GS
	150	8×6.2	0.19	15	0.40	230	UWG1A151MCL1GS
	220	8×10	0.19	22	0.30	450	UWG1A221MNL1GS
	470	10×10	0.19	47	0.15	670	UWG1A471MNL1GS
	1000	10×10	0.19	100	0.15	670	UWG1A102MNL1GS
16 (1C)	10	4×5.4	0.16	3	3.00	60	UWG1C100MCL1GB
	22	5×5.4	0.16	3.52	1.80	95	UWG1C220MCL1GB
	47	6.3×5.4	0.16	7.52	1.00	140	UWG1C470MCL1GB
	68	8×6.2	0.16	10.88	0.40	230	UWG1C680MCL1GS
	100	8×6.2	0.16	16	0.40	230	UWG1C101MCL1GS
	220	10×10	0.16	35.2	0.15	670	UWG1C221MNL1GS
	330	10×10	0.16	52.8	0.15	670	UWG1C331MNL1GS
	470	10×10	0.16	75.2	0.15	670	UWG1C471MNL1GS
	680	10×10	0.16	108.8	0.15	670	UWG1C681MNL1GS
25 (1E)	6.8	4×5.4	0.14	3	3.00	60	UWG1E68MCL1GB
	22	6.3×5.4	0.14	5.5	1.00	140	UWG1E220MCL1GB
	33	6.3×5.4	0.14	8.25	1.00	140	UWG1E330MCL1GB
	47	8×6.2	0.14	11.75	0.40	230	UWG1E470MCL1GS
	68	8×10	0.14	17	0.30	450	UWG1E680MNL1GS
	100	8×10	0.14	25	0.30	450	UWG1E101MNL1GS
	220	10×10	0.14	55	0.15	670	UWG1E221MNL1GS
	330	10×10	0.14	82.5	0.15	670	UWG1E331MNL1GS
	470	10×10	0.14	117.5	0.15	670	UWG1E471MNL1GS
35 (1V)	1	4×5.4	0.12	3	3.00	60	UWG1V010MCL1GB
	2.2	4×5.4	0.12	3	3.00	60	UWG1V2R2MCL1GB
	3.3	4×5.4	0.12	3	3.00	60	UWG1V3R3MCL1GB
	4.7	4×5.4	0.12	3	3.00	60	UWG1V4R7MCL1GB
	6.8	5×5.4	0.12	3	1.80	95	UWG1V6R8MCL1GB
	10	5×5.4	0.12	3.5	1.80	95	UWG1V100MCL1GB
	22	6.3×5.4	0.12	7.7	1.00	140	UWG1V220MCL1GB
	33	8×6.2	0.12	11.55	0.40	230	UWG1V330MCL1GS
	47	8×6.2	0.12	16.45	0.40	230	UWG1V470MCL1GS
	100	10×10	0.12	35	0.15	670	UWG1V101MNL1GS
	220	10×10	0.12	77	0.15	670	UWG1V221MNL1GS
	330	10×10	0.12	115.5	0.15	670	UWG1V331MNL1GS
	50 (1H)	1	4×5.4	0.12	3	5.00	30
2.2		4×5.4	0.12	3	5.00	30	UWG1H2R2MCL1GB
3.3		4×5.4	0.12	3	5.00	30	UWG1H3R3MCL1GB
4.7		5×5.4	0.12	3	3.00	50	UWG1H4R7MCL1GB
10		6.3×5.4	0.12	5	2.00	70	UWG1H100MCL1GB
22		8×6.2	0.12	11	0.70	120	UWG1H220MCL1GS
33		8×10	0.12	16.5	0.60	300	UWG1H330MNL1GS
47		10×10	0.12	23.5	0.30	500	UWG1H470MNL1GS
100		10×10	0.12	50	0.30	500	UWG1H101MNL1GS
220		10×10	0.12	110	0.30	500	UWG1H221MNL1GS

- For taping specifications, recommended land size/soldering by reflow and minimum order quantity, please refer to the Guidelines for Aluminum Electrolytic Capacitors.
- Please select UUJ if high C/V products are required.

ALUMINUM ELECTROLYTIC CAPACITORS

UUP

6mmL Chip Type, Bi-Polarized



- Chip type, bi-polarized withstanding high temperature range up to +105°C.
- Designed for surface mounting on high density PC board.
- Applicable to automatic mounting machine fed with carrier tape.
- Compliant to the RoHS directive (2011/65/EU,(EU)2015/863).
- AEC-Q200 compliant. Please contact us for details.

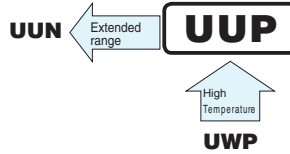

Specifications

Item	Performance Characteristics							
Category Temperature Range	-55 to +105°C							
Rated Voltage Range	6.3 to 50V							
Rated Capacitance Range	0.1 to 47μF							
Capacitance Tolerance	±20% at 120Hz, 20°C							
Leakage Current ※	After 2 minutes' application of rated voltage at 20°C, leakage current is not more than 0.05 CV or 10 (μA), whichever is greater.							
Tangent of loss angle (tan δ)	Measurement frequency : 120Hz at 20°C							
	Rated voltage (V)	6.3	10	16	25	35	50	
	tan δ (max.)	0.24	0.20	0.17	0.17	0.15	0.15	
Stability at Low Temperature	Measurement frequency : 120Hz							
	Rated voltage (V)		6.3	10	16	25	35	50
	Impedance ratio	Z(-25°C) / Z(+20°C)	4	3	2	2	2	2
	ZT / Z20 (max.)	Z(-40°C) / Z(+20°C)	8	6	4	4	3	3
Endurance	The specifications listed at right shall be met when the capacitors are restored to 20°C after the rated voltage is applied for 1000 hours at 105°C with the polarity every 250 hours.		Capacitance change	Within ±20% of the initial capacitance value				
			tan δ	200% or less than the initial specified value				
Shelf Life	After storing the capacitors under no load at 105°C for 1000 hours and then performing voltage treatment based on JIS C 5101-4 clause 4.1 at 20°C, they shall meet the specified values for the endurance characteristics listed above.		Leakage current	Less than or equal to the initial specified value				
Resistance to soldering heat	The capacitors are kept on a hot plate for 30 seconds, which is maintained at 250°C. The capacitors shall meet the characteristic requirements listed at right when they are removed from the plate and restored to 20°C.		Capacitance change	Within ±10% of the initial capacitance value				
			tan δ	Less than or equal to the initial specified value				
			Leakage current	Less than or equal to the initial specified value				
Marking	Black print on the case top.							

※ I : Leakage Current (μA), C : Rated Capacitance (μF), V : Rated Voltage (V)

Chip Type

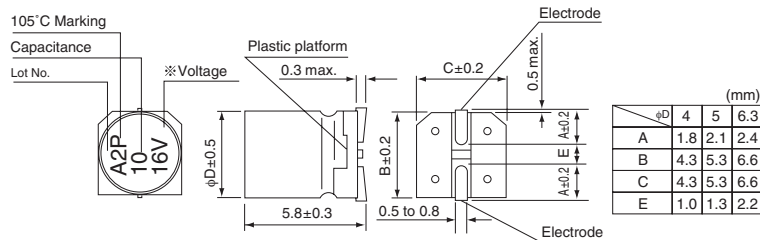

※ Voltage mark for 6.3V is 「6V」

Type numbering system (Example : 16V 10μF)

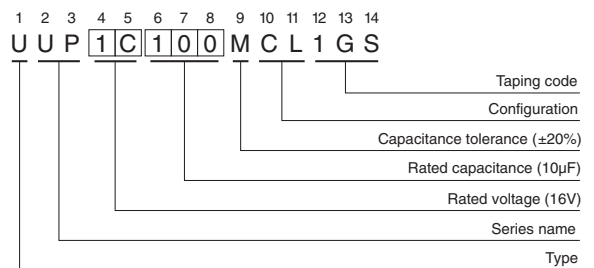

Frequency coefficient of rated ripple current

Frequency	50 Hz	120 Hz	300 Hz	1 kHz	10 kHz or more
Coefficient	0.70	1.00	1.17	1.36	1.50

● Dimension table in next page.

UUP

■ Dimensions

Rated Voltage (V) (code)	Rated Capacitance (μ F)	Case Size ϕ D \times L (mm)	tan δ	Leakage Current (μ A) (at 20°C after 2 minutes)	Rated Ripple (mArms) (105°C/120Hz)	Part Number
6.3 (0J)	22	5 \times 5.8	0.24	10	28	UUP0J220MCL1GS
	33	6.3 \times 5.8	0.24	10.395	37	UUP0J330MCL1GS
	47	6.3 \times 5.8	0.24	14.805	45	UUP0J470MCL1GS
10 (1A)	10	4 \times 5.8	0.20	10	17	UUP1A100MCL1GS
	22	6.3 \times 5.8	0.20	11	33	UUP1A220MCL1GS
	33	6.3 \times 5.8	0.20	16.5	41	UUP1A330MCL1GS
16 (1C)	4.7	4 \times 5.8	0.17	10	12	UUP1C4R7MCL1GS
	10	5 \times 5.8	0.17	10	23	UUP1C100MCL1GS
	22	6.3 \times 5.8	0.17	17.6	37	UUP1C220MCL1GS
	33	6.3 \times 5.8	0.17	26.4	49	UUP1C330MCL1GS
25 (1E)	3.3	5 \times 5.8	0.17	10	12	UUP1E3R3MCL1GS
	4.7	5 \times 5.8	0.17	10	16	UUP1E4R7MCL1GS
	10	6.3 \times 5.8	0.17	12.5	27	UUP1E100MCL1GS
35 (1V)	2.2	4 \times 5.8	0.15	10	8.4	UUP1V2R2MCL1GS
	3.3	5 \times 5.8	0.15	10	16	UUP1V3R3MCL1GS
	4.7	5 \times 5.8	0.15	10	18	UUP1V4R7MCL1GS
	10	6.3 \times 5.8	0.15	17.5	29	UUP1V100MCL1GS
50 (1H)	0.1	4 \times 5.8	0.15	10	1.0	UUP1H0R1MCL1GS
	0.22	4 \times 5.8	0.15	10	2.0	UUP1HR22MCL1GS
	0.33	4 \times 5.8	0.15	10	2.8	UUP1HR33MCL1GS
	0.47	4 \times 5.8	0.15	10	4.0	UUP1HR47MCL1GS
	1	4 \times 5.8	0.15	10	8.4	UUP1H010MCL1GS
	2.2	5 \times 5.8	0.15	10	13	UUP1H2R2MCL1GS
	3.3	5 \times 5.8	0.15	10	17	UUP1H3R3MCL1GS
	4.7	6.3 \times 5.8	0.15	11.75	20	UUP1H4R7MCL1GS

- For taping specifications, recommended land size/soldering by reflow and minimum order quantity, please refer to the Guidelines for Aluminum Electrolytic Capacitors.
- Please select UUN if high C/V products are required.

UUT 6mmL Chip Type, Wide Temperature Range



- Chip type with load life 2000 hours at +105°C.
- Designed for surface mounting on high density PC board.
- Applicable to automatic mounting machine fed with carrier tape.
- Compliant to the RoHS directive (2011/65/EU, (EU)2015/863).
- AEC-Q200 compliant. Please contact us for details.



Products which are scheduled to be discontinued.
Not recommended for new designs.



Specifications

Item	Performance Characteristics								
Category Temperature Range	-55 to +105°C								
Rated Voltage Range	4 to 50V								
Rated Capacitance Range	1 to 100μF								
Capacitance Tolerance	±20% at 120Hz, 20°C								
Leakage Current ※	After 2 minutes' application of rated voltage at 20°C, leakage current is not more than 0.01 CV or 3 (μA), whichever is greater.								
Tangent of loss angle (tan δ)	Measurement frequency : 120Hz at 20°C								
	Rated voltage (V)	4	6.3	10	16	25	35	50	
Stability at Low Temperature	Measurement frequency : 120Hz								
	Rated voltage (V)		4	6.3	10	16	25	35	50
	Impedance ratio	Z(-25°C) / Z(+20°C)	6	3	3	2	2	2	2
Endurance	The specifications listed at right shall be met when the capacitors are restored to 20°C after the rated voltage is applied for 2000 hours at 105°C.		Capacitance change		Within ±25% of the initial capacitance value (16V or less)				
			tan δ		200% or less than the initial specified value				
			Leakage current		Less than or equal to the initial specified value				
Shelf Life	After storing the capacitors under no load at 105°C for 1000 hours and then performing voltage treatment based on JIS C 5101-4 clause 4.1 at 20°C, they shall meet the specified values for the endurance characteristics listed above.								
Resistance to soldering heat	The capacitors are kept on a hot plate for 30 seconds, which is maintained at 250°C. The capacitors shall meet the characteristic requirements listed at right when they are removed from the plate and restored to 20°C.		Capacitance change		Within ±10% of the initial capacitance value				
Marking			tan δ		Less than or equal to the initial specified value				
			Leakage current		Less than or equal to the initial specified value				
Marking	Black print on the case top.								

※ I : Leakage Current (μA), C : Rated Capacitance (μF), V : Rated Voltage (V)

Chip Type

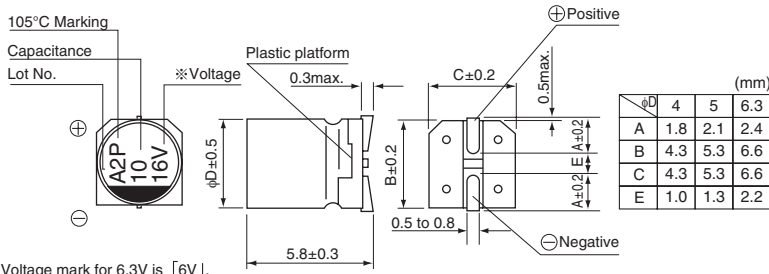

※ Voltage mark for 6.3V is 「6V」.

Type numbering system (Example : 16V 10μF)

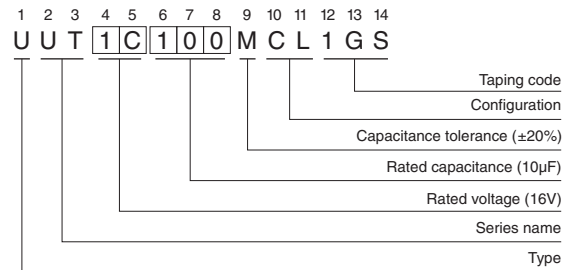

Frequency coefficient of rated ripple current

Frequency	50 Hz	120 Hz	300 Hz	1 kHz	10 kHz or more
Coefficient	0.70	1.00	1.17	1.36	1.50

● Dimension table in next page.

UUT

■ Dimensions

Rated Voltage (V) (code)	Rated Capacitance (μF)	Case Size φD×L (mm)	tan δ	Leakage Current (μA) (at 20°C after 2 minutes)	Rated Ripple (mArms) (105°C/120Hz)	Part Number
4 (0G)	22	4×5.8	0.37	3	22	UUT0G220MCL1GS
	33	5×5.8	0.37	3	30	UUT0G330MCL1GS
	47	5×5.8	0.37	3	36	UUT0G470MCL1GS
	100	6.3×5.8	0.37	4	60	UUT0G101MCL1GS
6.3 (0J)	22	4×5.8	0.28	3	22	UUT0J220MCL1GS
	33	5×5.8	0.28	3	30	UUT0J330MCL1GS
	47	5×5.8	0.28	3	36	UUT0J470MCL1GS
	100	6.3×5.8	0.28	6.3	60	UUT0J101MCL1GS
10 (1A)	22	5×5.8	0.24	3	27	UUT1A220MCL1GS
	33	5×5.8	0.24	3.3	35	UUT1A330MCL1GS
	47	6.3×5.8	0.24	4.7	46	UUT1A470MCL1GS
	100	6.3×5.8	0.24	10	60	UUT1A101MCL1GS
16 (1C)	10	4×5.8	0.20	3	18	UUT1C100MCL1GS
	22	5×5.8	0.20	3.52	30	UUT1C220MCL1GS
	33	6.3×5.8	0.20	5.28	40	UUT1C330MCL1GS
	47	6.3×5.8	0.20	7.52	50	UUT1C470MCL1GS
25 (1E)	4.7	4×5.8	0.16	3	13	UUT1E4R7MCL1GS
	10	5×5.8	0.16	3	23	UUT1E100MCL1GS
	22	6.3×5.8	0.16	5.5	38	UUT1E220MCL1GS
	33	6.3×5.8	0.16	8.25	48	UUT1E330MCL1GS
35 (1V)	4.7	4×5.8	0.13	3	15	UUT1V4R7MCL1GS
	10	5×5.8	0.13	3.5	25	UUT1V100MCL1GS
	22	6.3×5.8	0.13	7.7	42	UUT1V220MCL1GS
50 (1H)	1	4×5.8	0.12	3	6.2	UUT1H010MCL1GS
	2.2	4×5.8	0.12	3	11	UUT1H2R2MCL1GS
	3.3	4×5.8	0.12	3	14	UUT1H3R3MCL1GS
	4.7	5×5.8	0.12	3	19	UUT1H4R7MCL1GS
	10	6.3×5.8	0.12	5	30	UUT1H100MCL1GS

- For taping specifications, recommended land size/soldering by reflow and minimum order quantity, please refer to the Guidelines for Aluminum Electrolytic Capacitors.
- Please select UUX, UUU if high C/V products are required.

ALUMINUM ELECTROLYTIC CAPACITORS

UUA

6mmL Chip Type, Long Life Assurance



- Chip type with load life of 3000 to 5000 hours at +105°C.
- Designed for surface mounting on high density PC board.
- Compliant to the RoHS directive (2011/65/EU, (EU)2015/863).
- AEC-Q200 compliant. Please contact us for details.

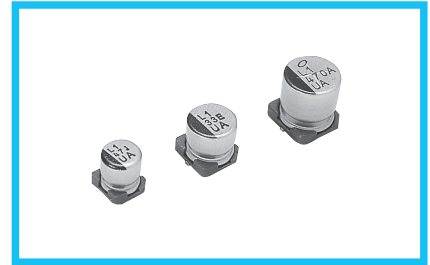

Specifications

Item	Performance Characteristics						
Category Temperature Range	-55 to +105°C						
Rated Voltage Range	6.3 to 50V						
Rated Capacitance Range	1 to 1000μF						
Capacitance Tolerance	±20% at 120Hz, 20°C						
Leakage Current ※	After 2 minutes' application of rated voltage at 20°C, leakage current is not more than 0.01 CV or 3 (μA), whichever is greater.						
Tangent of loss angle (tan δ)	Measurement frequency : 120Hz at 20°C						
	Rated voltage (V)	6.3	10	16	25	35	50
	tan δ (max.)	0.28	0.24	0.20	0.16	0.13	0.12
Stability at Low Temperature	Measurement frequency : 120Hz						
	Rated voltage (V)	6.3	10	16	25	35	50
	Impedance ratio Z(-25°C) / Z(+20°C)	4	3	2	2	2	2
	ZT / Z20 (max.)	Z(-55°C) / Z(+20°C)	10	7	5	3	3
Endurance	The specifications listed at right shall be met when the capacitors are restored to 20°C after the rated voltage is applied for 5000 hours (3000 hours for φD = 4, 5 and 6.3) at 105°C.						
	Capacitance change	Within ±30% of the initial capacitance value					
	tan δ	300% or less than the initial specified value					
	Leakage current	Less than or equal to the initial specified value					
Shelf Life	After storing the capacitors under no load at 105°C for 1000 hours and then performing voltage treatment based on JIS C 5101-4 clause 4.1 at 20°C, they shall meet the specified values for the endurance characteristics listed above.						
Resistance to soldering heat	The capacitors are kept on a hot plate for 30 seconds, which is maintained at 250°C. The capacitors shall meet the characteristic requirements listed at right when they are removed from the plate and restored to 20°C.						
	Capacitance change	Within ±10% of the initial capacitance value					
	tan δ	Less than or equal to the initial specified value					
	Leakage current	Less than or equal to the initial specified value					
Marking	Black print on the case top.						

※ I : Leakage Current (μA), C : Rated Capacitance (μF), V : Rated Voltage (V)

Chip Type

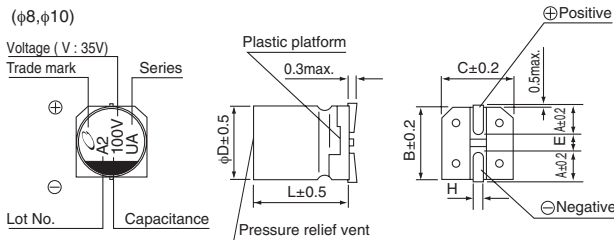
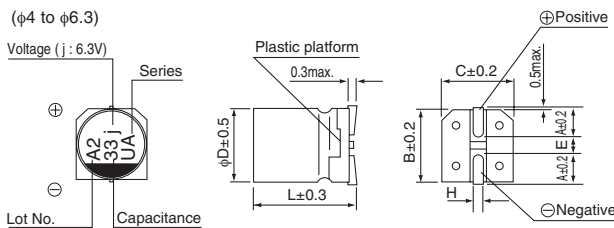

Type numbering system (Example : 16V 10μF)

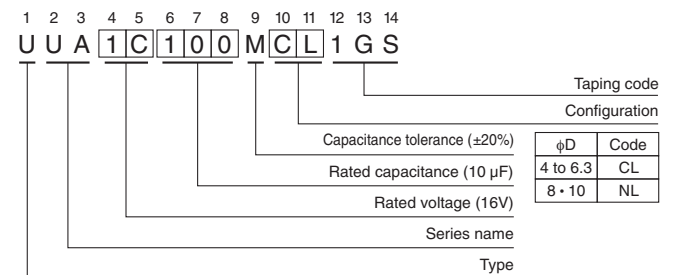

Voltage

V	6.3	10	16	25	35	50
Code	j	A	C	E	V	H

Frequency coefficient of rated ripple current

Frequency	50 Hz	120 Hz	300 Hz	1 kHz	10 kHz or more
Coefficient	0.70	1.00	1.17	1.36	1.50

● Dimension table in next page.

UUA

■ Dimensions

Rated Voltage (V) (code)	Rated Capacitance (μF)	Case Size φD×L (mm)	tan δ	Leakage Current (μA) (at 20°C after 2 minutes)	Rated Ripple (mArms) (105°C/120Hz)	Part Number
6.3 (0J)	22	4×5.8	0.28	3	22	UUA0J220MCL1GS
	33	5×5.8	0.28	3	35	UUA0J330MCL1GS
	47	5×5.8	0.28	3	38	UUA0J470MCL1GS
	100	6.3×5.8	0.28	6.3	69	UUA0J101MCL1GS
	220	6.3×7.7	0.28	13.86	120	UUA0J221MCL1GS
	330	8×10	0.28	20.79	290	UUA0J331MNL1GS
	470	10×10	0.28	29.61	320	UUA0J471MNL1GS
	1000	10×10	0.28	63	410	UUA0J102MNL1GS
10 (1A)	22	5×5.8	0.24	3	30	UUA1A220MCL1GS
	33	5×5.8	0.24	3.3	35	UUA1A330MCL1GS
	47	6.3×5.8	0.24	4.7	50	UUA1A470MCL1GS
	100	6.3×7.7	0.24	10	81	UUA1A101MCL1GS
	220	8×10	0.24	22	141	UUA1A221MNL1GS
	330	10×10	0.24	33	290	UUA1A331MNL1GS
	470	10×10	0.24	47	320	UUA1A471MNL1GS
	16 (1C)	10	4×5.8	0.20	3	18
22		5×5.8	0.20	3.52	30	UUA1C220MCL1GS
33		6.3×5.8	0.20	5.28	48	UUA1C330MCL1GS
47		6.3×5.8	0.20	7.52	50	UUA1C470MCL1GS
100		6.3×7.7	0.20	16	81	UUA1C101MCL1GS
220		10×10	0.20	35.2	216	UUA1C221MNL1GS
330		10×10	0.20	52.8	290	UUA1C331MNL1GS
470		10×10	0.20	75.2	320	UUA1C471MNL1GS
25 (1E)	10	5×5.8	0.16	3	27	UUA1E100MCL1GS
	22	6.3×5.8	0.16	5.5	44	UUA1E220MCL1GS
	33	6.3×5.8	0.16	8.25	50	UUA1E330MCL1GS
	47	6.3×7.7	0.16	11.75	63	UUA1E470MCL1GS
	100	8×10	0.16	25	116	UUA1E101MNL1GS
	220	10×10	0.16	55	320	UUA1E221MNL1GS
	330	10×10	0.16	82.5	450	UUA1E331MNL1GS
35 (1V)	4.7	4×5.8	0.13	3	16	UUA1V47R7MCL1GS
	10	5×5.8	0.13	3.5	27	UUA1V100MCL1GS
	22	6.3×5.8	0.13	7.7	44	UUA1V220MCL1GS
	33	6.3×7.7	0.13	11.55	57	UUA1V330MCL1GS
	47	8×10	0.13	16.45	92	UUA1V470MNL1GS
	100	10×10	0.13	35	151	UUA1V101MNL1GS
	220	10×10	0.13	77	375	UUA1V221MNL1GS
	50 (1H)	1	4×5.8	0.12	3	8
2.2		4×5.8	0.12	3	12	UUA1H2R2MCL1GS
3.3		4×5.8	0.12	3	17	UUA1H3R3MCL1GS
4.7		5×5.8	0.12	3	22	UUA1H4R7MCL1GS
10		6.3×5.8	0.12	5	32	UUA1H100MCL1GS
22		6.3×7.7	0.12	11	58	UUA1H220MCL1GS
33		8×10	0.12	16.5	140	UUA1H330MNL1GS
47		8×10	0.12	23.5	170	UUA1H470MNL1GS
100		10×10	0.12	50	310	UUA1H101MNL1GS

• For taping specifications, recommended land size/soldering by reflow and minimum order quantity, please refer to the Guidelines for Aluminum Electrolytic Capacitors.

ALUMINUM ELECTROLYTIC CAPACITORS



Chip Type, Long Life Assurance



- Chip type with load life of 5000 hours at +105°C.
- Designed for surface mounting on high density PC board.
- Compliant to the RoHS directive (2011/65/EU, (EU)2015/863).
- AEC-Q200 compliant. Please contact us for details.



Specifications

Item	Performance Characteristics							
Category Temperature Range	-40 to +105°C							
Rated Voltage Range	6.3 to 50V							
Rated Capacitance Range	1 to 1000μF							
Capacitance Tolerance	±20% at 120Hz, 20°C							
Leakage Current ※	After 2 minutes' application of rated voltage at 20°C, leakage current is not more than 0.01 CV or 3 (μA), Max							
Tangent of loss angle (tan δ)	Measurement frequency : 120Hz at 20°C							
	Rated voltage (V)	6.3	10	16	25	35	50	
Stability at Low Temperature	tan δ (max.)	0.32	0.24	0.20	0.16	0.13	0.12	
	Measurement frequency : 120Hz							
	Rated voltage (V)	6.3	10	16	25	35	50	
Endurance	Impedance ratio Z(-25°C) / Z(+20°C)	4	3	2	2	2	2	
	ZT / Z20 (max.)	Z(-40°C) / Z(+20°C)	10	7	5	3	3	3
Shelf Life	The specifications listed at right shall be met when the capacitors are restored to 20°C after the rated voltage is applied for 5000 hours at 105°C.		Capacitance change					Within ±30% of the initial capacitance value
			tan δ					300% or less than the initial specified value
			Leakage current					Less than or equal to the initial specified value
Resistance to soldering heat	After storing the capacitors under no load at 105°C for 1000 hours and then performing voltage treatment based on JIS C 5101-4 clause 4.1 at 20°C, they shall meet the specified values for the endurance characteristics listed above.		Capacitance change					Within ±10% of the initial capacitance value
			tan δ					Less than or equal to the initial specified value
			Leakage current					Less than or equal to the initial specified value
Marking	Black print on the case top.							

※ I : Leakage Current (μA), C : Rated Capacitance (μF), V : Rated Voltage (V)

Chip Type

(φ4 to φ6.3)

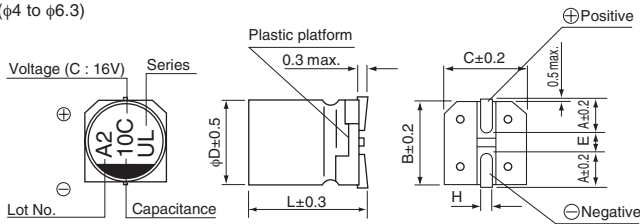

(φ8, φ10)

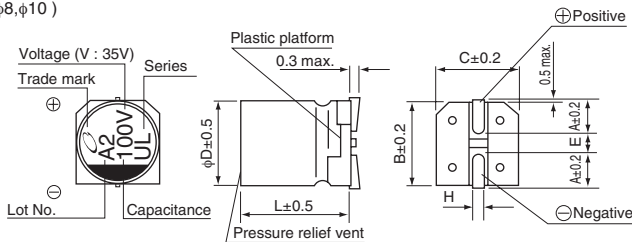

Voltage

V	6.3	10	16	25	35	50
Code	j	A	C	E	V	H

Type numbering system (Example : 16V 100μF)

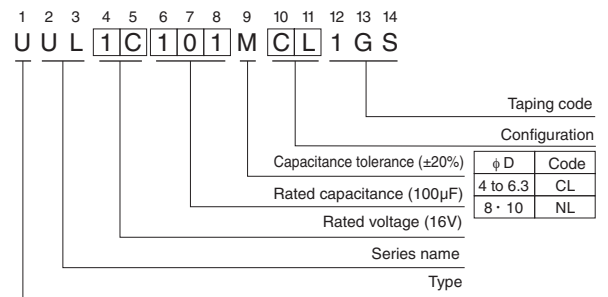

φ D × L (mm)	4 × 5.8	5 × 5.8	6.3 × 5.8	6.3 × 7.7	8 × 10	10 × 10
A	1.8	2.1	2.4	2.4	2.9	3.2
B	4.3	5.3	6.6	6.6	8.3	10.3
C	4.3	5.3	6.6	6.6	8.3	10.3
E	1.0	1.3	2.2	2.2	3.1	4.5
L	5.8	5.8	5.8	7.7	10	10
H	0.5 to 0.8	0.5 to 0.8	0.5 to 0.8	0.5 to 0.8	0.8 to 1.1	0.8 to 1.1

Frequency coefficient of rated ripple current

Frequency	50 Hz	120 Hz	300 Hz	1 kHz	10 kHz or more
Coefficient	0.70	1.00	1.17	1.36	1.50

● Dimension table in next page.

CAT.8100L

UUL

■ Dimensions

Rated Voltage (V) (code)	Rated Capacitance (μF)	Case Size φD×L (mm)	tan δ	Leakage Current (μA) (at 20°C after 2 minutes)	Rated Ripple (mArms) (105°C/120Hz)	Part Number
6.3 (0J)	33	5×5.8	0.32	3	35	UUL0J330MCL1GS
	47	5×5.8	0.32	3	36	UUL0J470MCL1GS
	100	6.3×5.8	0.32	6.3	60	UUL0J101MCL1GS
	220	6.3×7.7	0.32	13.86	101	UUL0J221MCL1GS
	330	8×10	0.32	20.79	160	UUL0J331MNL1GS
	470	10×10	0.32	29.61	254	UUL0J471MNL1GS
	1000	10×10	0.32	63	313	UUL0J102MNL1GS
10 (1A)	22	5×5.8	0.24	3	30	UUL1A220MCL1GS
	33	5×5.8	0.24	3.3	35	UUL1A330MCL1GS
	47	6.3×5.8	0.24	4.7	50	UUL1A470MCL1GS
	100	6.3×7.7	0.24	10	81	UUL1A101MCL1GS
	220	8×10	0.24	22	141	UUL1A221MNL1GS
	330	10×10	0.24	33	238	UUL1A331MNL1GS
	470	10×10	0.24	47	254	UUL1A471MNL1GS
16 (1C)	10	4×5.8	0.20	3	18	UUL1C100MCL1GS
	22	5×5.8	0.20	3.52	30	UUL1C220MCL1GS
	33	6.3×5.8	0.20	5.28	48	UUL1C330MCL1GS
	47	6.3×5.8	0.20	7.52	50	UUL1C470MCL1GS
	100	6.3×7.7	0.20	16	81	UUL1C101MCL1GS
	220	10×10	0.20	35.2	216	UUL1C221MNL1GS
	330	10×10	0.20	52.8	238	UUL1C331MNL1GS
	470	10×10	0.20	75.2	254	UUL1C471MNL1GS
25 (1E)	10	5×5.8	0.16	3	25	UUL1E100MCL1GS
	22	6.3×5.8	0.16	5.5	42	UUL1E220MCL1GS
	33	6.3×5.8	0.16	8.25	48	UUL1E330MCL1GS
	47	6.3×7.7	0.16	11.75	63	UUL1E470MCL1GS
	100	8×10	0.16	25	116	UUL1E101MNL1GS
	220	10×10	0.16	55	216	UUL1E221MNL1GS
	330	10×10	0.16	82.5	238	UUL1E331MNL1GS
35 (1V)	4.7	4×5.8	0.13	3	15	UUL1V470MCL1GS
	10	5×5.8	0.13	3.5	25	UUL1V100MCL1GS
	22	6.3×5.8	0.13	7.7	42	UUL1V220MCL1GS
	33	6.3×7.7	0.13	11.55	57	UUL1V330MCL1GS
	47	8×10	0.13	16.45	92	UUL1V470MNL1GS
	100	10×10	0.13	35	151	UUL1V101MNL1GS
	220	10×10	0.13	77	216	UUL1V221MNL1GS
50 (1H)	1	4×5.8	0.12	3	6.2	UUL1H010MCL1GS
	2.2	4×5.8	0.12	3	11	UUL1H2R2MCL1GS
	3.3	4×5.8	0.12	3	14	UUL1H3R3MCL1GS
	4.7	5×5.8	0.12	3	19	UUL1H4R7MCL1GS
	10	6.3×5.8	0.12	5	30	UUL1H100MCL1GS
	22	6.3×7.7	0.12	11	49	UUL1H220MCL1GS
	33	8×10	0.12	16.5	77	UUL1H330MNL1GS
	47	8×10	0.12	23.5	92	UUL1H470MNL1GS
	100	10×10	0.12	50	151	UUL1H101MNL1GS

• For taping specifications, recommended land size/soldering by reflow and minimum order quantity, please refer to the Guidelines for Aluminum Electrolytic Capacitors.

ALUMINUM ELECTROLYTIC CAPACITORS

UCB

Chip Type, Long Life Assurance



- Chip type with load life of 7000 hours at +105°C.
- Applicable to automatic mounting machine fed with carrier tape.
- Compliant to the RoHS directive (2011/65/EU,(EU)2015/863).
- AEC-Q200 compliant. Please contact us for details.

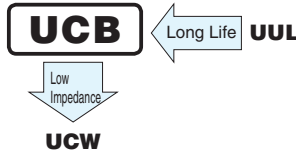

Specifications

Item	Performance Characteristics						
Category Temperature Range	-25 to +105°C						
Rated Voltage Range	6.3 to 50V						
Rated Capacitance Range	1 to 1000μF						
Capacitance Tolerance	±20% at 120Hz, 20°C						
Leakage Current ※	After 2 minutes' application of rated voltage at 20°C, leakage current is not more than 0.03 CV or 4 (μA) , whichever is greater.						
Tangent of loss angle (tan δ)	Measurement frequency : 120Hz at 20°C						
	Rated voltage (V)	6.3	10	16	25	35	50
	tan δ (max.)	0.32	0.28	0.26	0.16	0.14	0.14
Stability at Low Temperature	Measurement frequency : 120Hz						
	Rated voltage (V)	6.3	10	16	25	35	50
	Impedance ratio ZT / Z20 (max.)	Z(-25°C) / Z(+20°C)	4	3	2	2	2
Endurance	The specifications listed at right shall be met when the capacitors are restored to 20°C after the rated voltage is applied for 7000 hours at 105°C.						
	Capacitance change	Within ±30% of the initial capacitance value					
	tan δ	300% or less than the initial specified value					
	Leakage current	Less than or equal to the initial specified value					
Shelf Life	After storing the capacitors under no load at 105°C for 1000 hours and then performing voltage treatment based on JIS C 5101-4 clause 4.1 at 20°C, they shall meet the specified values for the endurance characteristics listed above.						
Resistance to soldering heat	The capacitors are kept on a hot plate for 30 seconds, which is maintained at 250°C. The capacitors shall meet the characteristic requirements listed at right when they are removed from the plate and restored to 20°C.						
	Capacitance change	Within ±10% of the initial capacitance value					
	tan δ	Less than or equal to the initial specified value					
	Leakage current	Less than or equal to the initial specified value					
Marking	Black print on the case top.						

※ I : Leakage Current (μA), C : Rated Capacitance (μF), V : Rated Voltage (V)

Chip Type

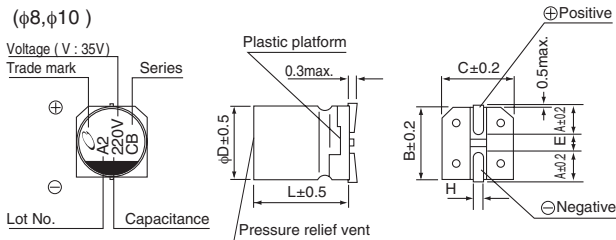
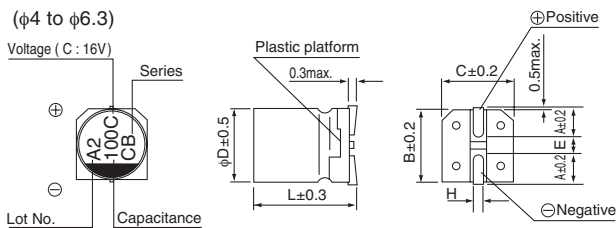

Type numbering system (Example : 16V 100μF)

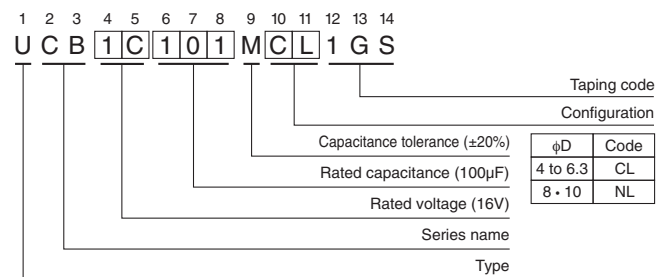

φD × L	(mm)					
A	4 × 7	5 × 7	6.3 × 7	6.3 × 8.7	8 × 10	10 × 10
B	1.8	2.1	2.4	2.4	2.9	3.2
C	4.3	5.3	6.6	6.6	8.3	10.3
E	4.3	5.3	6.6	6.6	8.3	10.3
L	1.0	1.3	2.2	2.2	3.1	4.5
H	7.0	7.0	7.0	8.7	10	10
	0.5 to 0.8	0.5 to 0.8	0.5 to 0.8	0.5 to 0.8	0.8 to 1.1	0.8 to 1.1

Voltage

V	6.3	10	16	25	35	50
Code	j	A	C	E	V	H

Frequency coefficient of rated ripple current

Frequency	50 Hz	120 Hz	300 Hz	1 kHz	10 kHz or more
Coefficient	0.70	1.00	1.17	1.36	1.50

● Dimension table in next page.

UCB

■ Dimensions

Rated Voltage (V) (code)	Rated Capacitance (μ F)	Case Size ϕ D \times L (mm)	$\tan \delta$	Leakage Current (μ A) (at 20°C after 2 minutes)	Rated Ripple (mArms) (105°C/120Hz)	Part Number
6.3 (0J)	22	4 \times 7	0.32	4.158	22	UCB0J220MCL1GS
	47	5 \times 7	0.32	8.883	36	UCB0J470MCL1GS
	100	6.3 \times 7	0.32	18.9	60	UCB0J101MCL1GS
	220	6.3 \times 8.7	0.32	41.58	101	UCB0J221MCL1GS
	330	8 \times 10	0.32	62.37	160	UCB0J331MNL1GS
	1000	10 \times 10	0.32	189	313	UCB0J102MNL1GS
10 (1A)	33	5 \times 7	0.28	9.9	35	UCB1A330MCL1GS
	220	8 \times 10	0.28	66	141	UCB1A221MNL1GS
16 (1C)	10	4 \times 7	0.26	4.8	18	UCB1C100MCL1GS
	22	5 \times 7	0.26	10.56	30	UCB1C220MCL1GS
	47	6.3 \times 7	0.26	22.56	50	UCB1C470MCL1GS
	100	6.3 \times 8.7	0.26	48	81	UCB1C101MCL1GS
	470	10 \times 10	0.26	225.6	254	UCB1C471MNL1GS
25 (1E)	33	6.3 \times 7	0.16	24.75	48	UCB1E330MCL1GS
	47	6.3 \times 8.7	0.16	35.25	63	UCB1E470MCL1GS
	100	8 \times 10	0.16	75	116	UCB1E101MNL1GS
35 (1V)	1	4 \times 7	0.14	4	6.2	UCB1V010MCL1GS
	2.2	4 \times 7	0.14	4	11	UCB1V2R2MCL1GS
	3.3	4 \times 7	0.14	4	14	UCB1V3R3MCL1GS
	4.7	4 \times 7	0.14	4.935	15	UCB1V4R7MCL1GS
	10	5 \times 7	0.14	10.5	25	UCB1V100MCL1GS
	22	6.3 \times 7	0.14	23.1	42	UCB1V220MCL1GS
	33	6.3 \times 8.7	0.14	34.65	57	UCB1V330MCL1GS
	220	10 \times 10	0.14	231	216	UCB1V221MNL1GS
50 (1H)	33	8 \times 10	0.14	49.5	77	UCB1H330MNL1GS
	47	8 \times 10	0.14	70.5	92	UCB1H470MNL1GS
	100	10 \times 10	0.14	150	151	UCB1H101MNL1GS

• For taping specifications, recommended land size/soldering by reflow and minimum order quantity, please refer to the Guidelines for Aluminum Electrolytic Capacitors.

ALUMINUM ELECTROLYTIC CAPACITORS

UCW

Chip Type, Low Impedance,
Long Life Assurance



- Chip type with load life of 7000 hours at +105°C.
Low impedance temperature range up to +105°C.
- Applicable to automatic mounting machine fed with carrier tape.
- Compliant to the RoHS directive (2011/65/EU, (EU)2015/863).
- AEC-Q200 compliant. Please contact us for details.



Specifications

Item	Performance Characteristics						
Category Temperature Range	-25 to +105°C						
Rated Voltage Range	6.3 to 50V						
Rated Capacitance Range	10 to 470μF						
Capacitance Tolerance	±20% at 120Hz, 20°C						
Leakage Current ※	After 2 minutes' application of rated voltage at 20°C, leakage current is not more than 0.01 CV or 3 (μA), whichever is greater.						
Tangent of loss angle (tan δ)	Measurement frequency : 120Hz at 20°C						
	Rated voltage (V)	6.3	10	16	25	35	50
	tan δ (max.)	0.32	0.28	0.26	0.16	0.14	0.14
Stability at Low Temperature	Measurement frequency : 120Hz						
	Rated voltage (V)	6.3	10	16	25	35	50
	Impedance ratio ZT / Z20 (max.)	Z(-25°C) / Z(+20°C)	4	3	2	2	2
Endurance	The specifications listed at right shall be met when the capacitors are restored to 20°C after the rated voltage is applied for 7000 hours at 105°C.						
	Capacitance change	Within ±30% of the initial capacitance value					
	tan δ	300% or less than the initial specified value					
	Leakage current	Less than or equal to the initial specified value					
Shelf Life	After storing the capacitors under no load at 105°C for 1000 hours and then performing voltage treatment based on JIS C 5101-4 clause 4.1 at 20°C, they shall meet the specified values for the endurance characteristics listed above.						
Resistance to soldering heat	The capacitors are kept on a hot plate for 30 seconds, which is maintained at 250°C. The capacitors shall meet the characteristic requirements listed at right when they are removed from the plate and restored to 20°C.						
	Capacitance change	Within ±10% of the initial capacitance value					
	tan δ	Less than or equal to the initial specified value					
	Leakage current	Less than or equal to the initial specified value					
Marking	Black print on the case top.						

※ I : Leakage Current (μA), C : Rated Capacitance (μF), V : Rated Voltage (V)

Chip Type

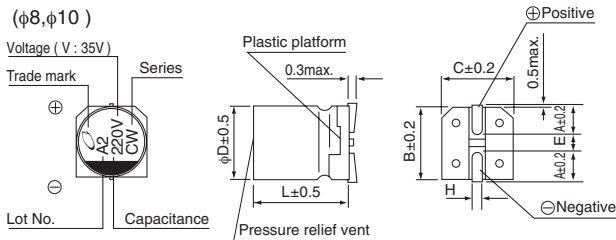
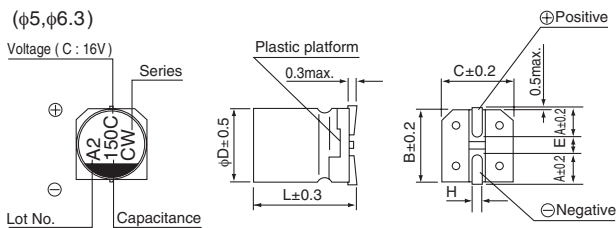

Type numbering system (Example : 10V 150μF)

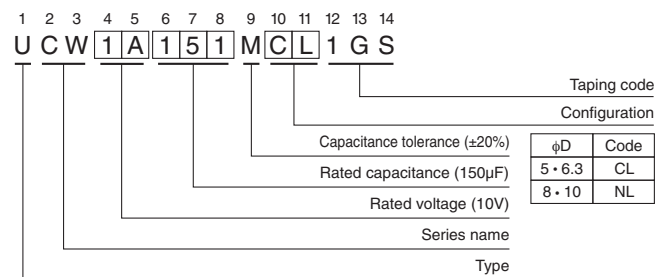

(mm)

φD × L	5 × 7	6.3 × 7	6.3 × 8.7	8 × 10	10 × 10
A	2.1	2.4	2.4	2.9	3.2
B	5.3	6.6	6.6	8.3	10.3
C	5.3	6.6	6.6	8.3	10.3
E	1.3	2.2	2.2	3.1	4.5
L	7.0	7.0	8.7	10	10
H	0.5 to 0.8	0.5 to 0.8	0.5 to 0.8	0.8 to 1.1	0.8 to 1.1

Voltage

V	6.3	10	16	25	35	50
Code	j	A	C	E	V	H

Frequency coefficient of rated ripple current

Frequency	50 Hz	120 Hz	300 Hz	1 kHz	10 kHz or more
Coefficient	0.35	0.50	0.64	0.83	1.00

● Dimension table in next page.

UCW

■ Dimensions

Rated Voltage (V) (code)	Rated Capacitance (μF)	Case Size φD×L (mm)	tan δ	Leakage Current (μA) (at 20°C after 2 minutes)	Impedance (Ω) max. (20°C/100kHz)	Rated Ripple (mA rms) (105°C/100kHz)	Part Number
6.3 (0J)	47	5×7	0.32	3	2.20	95	UCW0J470MCL1GS
	100	6.3×7	0.32	6.3	1.10	140	UCW0J101MCL1GS
	220	6.3×8.7	0.32	13.86	1.00	230	UCW0J221MCL1GS
	330	6.3×8.7	0.32	20.79	1.00	230	UCW0J331MCL1GS
	470	8×10	0.32	29.61	0.22	600	UCW0J471MNL1GS
10 (1A)	33	5×7	0.28	3.3	2.20	95	UCW1A330MCL1GS
	150	6.3×7	0.28	15	1.10	140	UCW1A151MCL1GS
16 (1C)	22	5×7	0.26	3.52	2.20	95	UCW1C220MCL1GS
	47	6.3×7	0.26	7.52	1.10	140	UCW1C470MCL1GS
	100	6.3×7	0.26	16	1.10	140	UCW1C101MCL1GS
	150	6.3×8.7	0.26	24	1.00	230	UCW1C151MCL1GS
	220	6.3×8.7	0.26	35.2	1.00	230	UCW1C221MCL1GS
	330	8×10	0.26	52.8	0.22	600	UCW1C331MNL1GS
	470	8×10	0.26	75.2	0.22	600	UCW1C471MNL1GS
25 (1E)	22	5×7	0.16	5.5	2.20	95	UCW1E220MCL1GS
	33	6.3×7	0.16	8.25	1.10	140	UCW1E330MCL1GS
	47	6.3×7	0.16	11.75	1.10	140	UCW1E470MCL1GS
	100	6.3×8.7	0.16	25	1.00	230	UCW1E101MCL1GS
	220	8×10	0.16	55	0.22	600	UCW1E221MNL1GS
	330	8×10	0.16	82.5	0.22	600	UCW1E331MNL1GS
	470	10×10	0.16	117.5	0.16	850	UCW1E471MNL1GS
35 (1V)	10	5×7	0.14	3.5	2.20	95	UCW1V100MCL1GS
	22	5×7	0.14	7.7	2.20	95	UCW1V220MCL1GS
	33	6.3×8.7	0.14	11.55	1.00	230	UCW1V330MCL1GS
	47	6.3×8.7	0.14	16.45	1.00	230	UCW1V470MCL1GS
	220	8×10	0.14	77	0.22	600	UCW1V221MNL1GS
	330	10×10	0.14	115.5	0.16	850	UCW1V331MNL1GS
50 (1H)	47	8×10	0.14	23.5	0.53	350	UCW1H470MNL1GS
	100	8×10	0.14	50	0.53	350	UCW1H101MNL1GS
	220	10×10	0.14	110	0.35	670	UCW1H221MNL1GS

• For taping specifications, recommended land size/soldering by reflow and minimum order quantity, please refer to the Guidelines for Aluminum Electrolytic Capacitors.

ALUMINUM ELECTROLYTIC CAPACITORS



UCD Chip Type, Low Impedance



- Chip type, low impedance temperature range up to +105°C.
- Designed for surface mounting on high density PC board.
- Applicable to automatic mounting machine fed with carrier tape.
- Compliant to the RoHS directive (2011/65/EU, (EU)2015/863).
- AEC-Q200 compliant. Please contact us for details.



Item	Performance Characteristics											
Category Temperature Range	- 55 to +105°C											
Rated Voltage Range	6.3 to 100V											
Rated Capacitance Range	1 to 3300μF											
Capacitance Tolerance	±20% at 120Hz, 20°C											
Leakage Current ※	After 2 minutes' application of rated voltage at 20°C, leakage current is not more than 0.01 CV or 3 (μA), whichever is greater.											
Tangent of loss angle (tan δ)	Rated voltage (V)	6.3	10	16	25	35	50	63	80	100	Measurement frequency: 120Hz at 20°C	
	tan δ (max.)	0.26	0.19	0.16	0.14	0.12	0.10	0.08	0.08	0.07		
For capacitance of more than 1000μF, add 0.02 for every increase of 1000μF. (φ12.5 to φ18)												
Stability at Low Temperature	Rated voltage (V)	6.3	10	16	25	35	50	63	80	100	Measurement frequency: 120Hz	
	Impedance ratio (max.)	Z(-25°C) / Z(+20°C)	2	2	2	2	2	2	2	2		2
		Z(-40°C) / Z(+20°C)	3	3	3	3	3	3	3	3		3
	Z(-55°C) / Z(+20°C)	4	4	4	3	3	3	3	3	3		
Endurance	The specifications listed below shall be met when the capacitors are restored to 20°C after the rated voltage is applied at 105°C for the conditions listed at right.											
	Rated Voltage	Size (mm)		~7.7L	10L	φ10×13.5L	13.5L~					
	6.3~50V			2000hrs.	5000hrs.	5000hrs.	5000hrs.					
	63~100V			2000hrs.	2000hrs.	—	5000hrs.					
	Capacitance Change	Within ± 30% of the initial capacitance value										
	tan δ	200% or less than the initial specified value										
	Leakage current	300% or less than the initial specified value for 63V or more										
	Leakage current	Less than or equal to the initial specified value										
Shelf Life	After storing the capacitors under no load at 105°C for 1000 hours and then performing voltage treatment based on JIS C 5101-4 clause 4.1 at 20°C, they shall meet the specified values for the endurance characteristics listed above.											
Resistance to soldering heat	The capacitors are kept on a hot plate for 30 seconds, which is maintained at 250°C. The capacitors shall meet the characteristic requirements listed at right when they are removed from the plate and restored to 20°C.											
	Capacitance Change	Within ± 10% of the initial capacitance value										
	tan δ	Less than or equal to the initial specified value										
	Leakage current	Less than or equal to the initial specified value										
Marking	Black print on the case top.											

Chip Type

(φ4 to φ8 × 6.2)

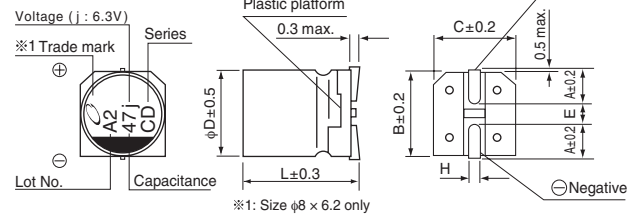

(φ8 × 10, φ10)

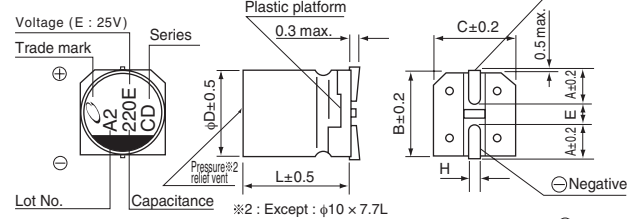

(φ12.5 to φ18)

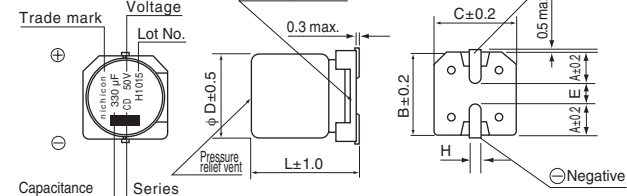

For φ8×10L, φ10×10L, φ12.5×13.5L, φ16×16.5L, and φ18×16.5L, some part numbers can be produced vibration-resistant construction. Please contact us for details.

• Dimension table in next page.

※ I : Leakage Current (μA), C : Rated Capacitance (μF), V : Rated Voltage (V)

Type numbering system (Example : 16V 100μF)

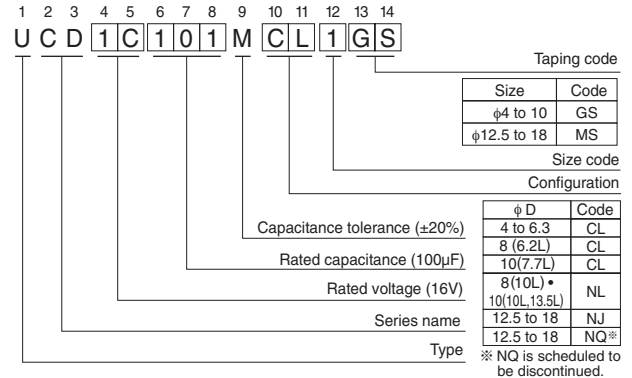

φD×L	4 × 5.8	5 × 5.8	6.3 × 5.8	6.3 × 7.7	8 × 6.2	8 × 10	10 × 7.7	10 × 10
A	1.8	2.1	2.4	2.4	3.3	2.9	3.2	3.2
B	4.3	5.3	6.6	6.6	8.3	8.3	10.3	10.3
C	4.3	5.3	6.6	6.6	8.3	8.3	10.3	10.3
E	1.0	1.3	2.2	2.2	2.3	3.1	4.5	4.5
L	5.8	5.8	5.8	7.7	6.2	10	7.7	10
H	0.5 to 0.8	0.5 to 0.8	0.5 to 0.8	0.5 to 0.8	0.5 to 0.8	0.8 to 1.1	0.8 to 1.1	0.8 to 1.1

φD×L	10 × 13.5	12.5 × 13.5	16 × 16.5	18 × 16.5
A	3.2	5.15	5.65	6.65
B	10.3	13.6	17.1	19.1
C	10.3	13.6	17.1	19.1
E	4.5	(3.3)	(5.8)	(5.8)
L	13.5	13.5	16.5	16.5
H	0.8 to 1.1	1.0 to 1.4	1.0 to 1.4	1.0 to 1.4

Please contact us for the dimensions for NQ.

Voltage

V	6.3	10	16	25	35	50	63	80	100
Code	j	A	C	E	V	H	J	K	2A

• Frequency coefficient of rated ripple current

Frequency	50Hz	120Hz	300Hz	1kHz	10kHz or more
Coefficient	0.35	0.50	0.64	0.83	1.00

CAT.8100L

UCD

■ Dimensions

Rated Voltage (V) (code)	Rated Capacitance (μF)	Case Size φD×L (mm)	tan δ	Leakage Current (μA) (at 20°C after 2 minutes)	Impedance (Ω) max. (20°C/100kHz)	Rated Ripple (mA rms) (105°C/100kHz)	Part Number
6.3 (0J)	22	4×5.8	0.26	3	1.35	90	UCD0J220MCL1GS
	27	4×5.8	0.26	3	1.35	90	UCD0J270MCL1GS
	33	5×5.8	0.26	3	0.70	160	UCD0J330MCL1GS
	47	4×5.8	0.26	3	1.35	90	UCD0J470MCL6GS
	47	5×5.8	0.26	3	0.70	160	UCD0J470MCL1GS
	56	5×5.8	0.26	3.528	0.70	160	UCD0J560MCL1GS
	68	6.3×5.8	0.26	4.284	0.36	240	UCD0J680MCL1GS
	100	5×5.8	0.26	6.3	0.70	160	UCD0J101MCL6GS
	100	6.3×5.8	0.26	6.3	0.36	240	UCD0J101MCL1GS
	150	6.3×5.8	0.26	9.45	0.36	240	UCD0J151MCL1GS
	220	6.3×5.8	0.26	13.86	0.36	240	UCD0J221MCL1GS
	330	6.3×7.7	0.26	20.79	0.32	290	UCD0J331MCL1GS
	330	8×6.2	0.26	20.79	0.26	300	UCD0J331MCL6GS
	470	8×10	0.26	29.61	0.16	600	UCD0J471MNL1GS
	470	10×7.7	0.26	29.61	0.18	600	UCD0J471MCL6GS
	680	8×10	0.26	42.84	0.16	600	UCD0J681MNL1GS
	680	10×7.7	0.26	42.84	0.18	600	UCD0J681MCL6GS
	1000	8×10	0.26	63	0.16	600	UCD0J102MNL1GS
	1500	10×10	0.26	94.5	0.080	850	UCD0J152MNL1GS
2200	10×13.5	0.26	138.6	0.080	950	UCD0J222MNL1GS	
3300	12.5×13.5	0.30	207.9	0.080	1100	UCD0J332MNL1MS	
10 (1A)	22	4×5.8	0.19	3	1.35	90	UCD1A220MCL1GS
	27	5×5.8	0.19	3	0.70	160	UCD1A270MCL1GS
	33	4×5.8	0.19	3.3	1.35	90	UCD1A330MCL6GS
	33	5×5.8	0.19	3.3	0.70	160	UCD1A330MCL1GS
	47	6.3×5.8	0.19	4.7	0.36	240	UCD1A470MCL1GS
	56	6.3×5.8	0.19	5.6	0.36	240	UCD1A560MCL1GS
	68	6.3×5.8	0.19	6.8	0.36	240	UCD1A680MCL1GS
	100	6.3×5.8	0.19	10	0.36	240	UCD1A101MCL1GS
	150	6.3×5.8	0.19	15	0.36	240	UCD1A151MCL1GS
	220	6.3×7.7	0.19	22	0.32	290	UCD1A221MCL1GS
	220	8×6.2	0.19	22	0.26	300	UCD1A221MCL6GS
	330	8×10	0.19	33	0.16	600	UCD1A331MNL1GS
	330	10×7.7	0.19	33	0.18	600	UCD1A331MCL6GS
	470	8×10	0.19	47	0.16	600	UCD1A471MNL1GS
	470	10×7.7	0.19	47	0.18	600	UCD1A471MCL6GS
	680	10×10	0.19	68	0.080	850	UCD1A681MNL1GS
	1000	10×10	0.19	100	0.080	850	UCD1A102MNL1GS
	1500	10×13.5	0.19	150	0.080	950	UCD1A152MNL1GS
	2200	12.5×13.5	0.21	220	0.080	1100	UCD1A222MNL1MS
16 (1C)	10	4×5.8	0.16	3	1.35	90	UCD1C100MCL1GS
	15	4×5.8	0.16	3	1.35	90	UCD1C150MCL1GS
	22	4×5.8	0.16	3.52	1.35	90	UCD1C220MCL6GS
	22	5×5.8	0.16	3.52	0.70	160	UCD1C220MCL1GS
	27	5×5.8	0.16	4.32	0.70	160	UCD1C270MCL1GS
	33	6.3×5.8	0.16	5.28	0.36	240	UCD1C330MCL1GS
	47	5×5.8	0.16	7.52	0.70	160	UCD1C470MCL6GS
	47	6.3×5.8	0.16	7.52	0.36	240	UCD1C470MCL1GS
	56	6.3×5.8	0.16	8.96	0.36	240	UCD1C560MCL1GS
	68	6.3×5.8	0.16	10.88	0.36	240	UCD1C680MCL1GS
	100	6.3×5.8	0.16	16	0.36	240	UCD1C101MCL1GS

UCD

■ Dimensions

Rated Voltage (V) (code)	Rated Capacitance (μF)	Case Size φD×L (mm)	tan δ	Leakage Current (μA) (at 20°C after 2 minutes)	Impedance (Ω) max. (20°C/100kHz)	Rated Ripple (mArms) (105°C/100kHz)	Part Number
16 (1C)	150	6.3×7.7	0.16	24	0.32	290	UCD1C151MCL1GS
	220	6.3×7.7	0.16	35.2	0.32	290	UCD1C221MCL1GS
	220	8×6.2	0.16	35.2	0.26	300	UCD1C221MCL6GS
	330	8×10	0.16	52.8	0.16	600	UCD1C331MNL1GS
	330	10×7.7	0.16	52.8	0.18	600	UCD1C331MCL6GS
	470	8×10	0.16	75.2	0.16	600	UCD1C471MNL1GS
	470	10×7.7	0.16	75.2	0.18	600	UCD1C471MCL6GS
	680	10×10	0.16	108.8	0.080	850	UCD1C681MNL1GS
	1000	10×13.5	0.16	160	0.080	950	UCD1C102MNL1GS
	1500	12.5×13.5	0.16	240	0.080	1100	UCD1C152MNJ1MS
25 (1E)	10	4×5.8	0.14	3	1.35	90	UCD1E100MCL1GS
	15	5×5.8	0.14	3.75	0.70	160	UCD1E150MCL1GS
	22	5×5.8	0.14	5.5	0.70	160	UCD1E220MCL1GS
	27	6.3×5.8	0.14	6.75	0.36	240	UCD1E270MCL1GS
	33	5×5.8	0.14	8.25	0.70	160	UCD1E330MCL6GS
	33	6.3×5.8	0.14	8.25	0.36	240	UCD1E330MCL1GS
	47	6.3×5.8	0.14	11.75	0.36	240	UCD1E470MCL1GS
	56	6.3×5.8	0.14	14	0.36	240	UCD1E560MCL1GS
	68	6.3×5.8	0.14	17	0.36	240	UCD1E680MCL1GS
	100	6.3×7.7	0.14	25	0.32	290	UCD1E101MCL1GS
	100	8×6.2	0.14	25	0.26	300	UCD1E101MCL6GS
	150	8×10	0.14	37.5	0.16	600	UCD1E151MNL1GS
	150	10×7.7	0.14	37.5	0.18	600	UCD1E151MCL6GS
	220	8×10	0.14	55	0.16	600	UCD1E221MNL1GS
	220	10×7.7	0.14	55	0.18	600	UCD1E221MCL6GS
	330	8×10	0.14	82.5	0.16	600	UCD1E331MNL1GS
	470	10×10	0.14	117.5	0.080	850	UCD1E471MNL1GS
	680	10×13.5	0.14	170	0.080	950	UCD1E681MNL1GS
1000	12.5×13.5	0.14	250	0.080	1100	UCD1E102MNJ1MS	
	2200	16×16.5	0.16	550	0.035	1800	UCD1E222MNJ1MS
35 (1V)	4.7	4×5.8	0.12	3	1.35	90	UCD1V47R7MCL1GS
	10	4×5.8	0.12	3.5	1.35	90	UCD1V100MCL6GS
	10	5×5.8	0.12	3.5	0.70	160	UCD1V100MCL1GS
	22	5×5.8	0.12	7.7	0.70	160	UCD1V220MCL1GS
	33	6.3×5.8	0.12	11.55	0.36	240	UCD1V330MCL1GS
	47	6.3×5.8	0.12	16.45	0.36	240	UCD1V470MCL1GS
	68	6.3×7.7	0.12	23.8	0.32	290	UCD1V680MCL1GS
	100	6.3×7.7	0.12	35	0.32	290	UCD1V101MCL6GS
	100	8×10	0.12	35	0.16	600	UCD1V101MNL1GS
	150	8×10	0.12	52.5	0.16	600	UCD1V151MNL1GS
	150	10×7.7	0.12	52.5	0.18	600	UCD1V151MCL6GS
	220	8×10	0.12	77	0.16	600	UCD1V221MNL1GS
	220	10×7.7	0.12	77	0.18	600	UCD1V221MCL6GS
	330	10×10	0.12	115.5	0.080	850	UCD1V331MNL1GS
	470	10×13.5	0.12	164.5	0.080	950	UCD1V471MNL6GS
	470	12.5×13.5	0.12	164.5	0.080	1100	UCD1V471MNJ1MS
	680	12.5×13.5	0.12	238	0.080	1100	UCD1V681MNJ1MS
1000	16×16.5	0.12	350	0.035	1800	UCD1V102MNJ1MS	
50 (1H)	1	4×5.8	0.10	3	2.70	60	UCD1H010MCL1GS
	2.2	4×5.8	0.10	3	2.70	60	UCD1H2R2MCL1GS
	3.3	4×5.8	0.10	3	2.70	60	UCD1H3R3MCL1GS

UCD

■ Dimensions

Rated Voltage (V) (code)	Rated Capacitance (μF)	Case Size φD×L (mm)	tan δ	Leakage Current (μA) (at 20°C after 2 minutes)	Impedance (Ω) max. (20°C/100kHz)	Rated Ripple (mA rms) (105°C/100kHz)	Part Number
50 (1H)	4.7	4×5.8	0.10	3	2.70	60	UCD1H4R7MCL1GS
	10	5×5.8	0.10	5	1.50	90	UCD1H100MCL6GS
	10	6.3×5.8	0.10	5	0.86	170	UCD1H100MCL1GS
	22	6.3×5.8	0.10	11	0.86	170	UCD1H220MCL1GS
	33	6.3×7.7	0.10	16.5	0.66	195	UCD1H330MCL1GS
	33	8×6.2	0.10	16.5	0.63	200	UCD1H330MCL6GS
	47	6.3×7.7	0.10	23.5	0.66	195	UCD1H470MCL1GS
	47	8×6.2	0.10	23.5	0.63	200	UCD1H470MCL6GS
	100	8×10	0.10	50	0.32	350	UCD1H101MNL1GS
	100	10×7.7	0.10	50	0.36	330	UCD1H101MCL6GS
	150	10×10	0.10	75	0.16	700	UCD1H151MNL1GS
	220	10×10	0.10	110	0.16	700	UCD1H221MNL1GS
	330	10×13.5	0.10	165	0.14	800	UCD1H331MNL6GS
	330	12.5×13.5	0.10	165	0.12	900	UCD1H331MNL1MS
	390	12.5×13.5	0.10	195	0.12	900	UCD1H391MNL1MS
470	16×16.5	0.10	235	0.073	1610	UCD1H471MNL1MS	
680	16×16.5	0.10	340	0.073	1610	UCD1H681MNL1MS	
63 (1J)	4.7	5×5.8	0.08	3	3.00	50	UCD1J4R7MCL1GS
	10	6.3×5.8	0.08	6.3	1.50	80	UCD1J100MCL1GS
	22	6.3×7.7	0.08	13.86	1.20	120	UCD1J220MCL1GS
	22	8×6.2	0.08	13.86	1.20	120	UCD1J220MCL6GS
	33	8×10	0.08	20.79	0.65	250	UCD1J330MNL1GS
	47	8×10	0.08	29.61	0.65	250	UCD1J470MNL1GS
	68	10×10	0.08	42.84	0.35	400	UCD1J680MNL1GS
	100	10×10	0.08	63	0.35	400	UCD1J101MNL1GS
	150	12.5×13.5	0.08	94.5	0.16	800	UCD1J151MNL1MS
	220	12.5×13.5	0.08	138.6	0.16	800	UCD1J221MNL1MS
	470	16×16.5	0.08	296.1	0.082	1410	UCD1J471MNL1MS
680	18×16.5	0.08	428.4	0.080	1690	UCD1J681MNL1MS	
80 (1K)	3.3	5×5.8	0.08	3	5.00	25	UCD1K3R3MCL1GS
	4.7	6.3×5.8	0.08	3.76	3.00	40	UCD1K4R7MCL1GS
	10	6.3×7.7	0.08	8	2.40	60	UCD1K100MCL1GS
	10	8×6.2	0.08	8	2.40	60	UCD1K100MCL6GS
	22	8×10	0.08	17.6	1.30	130	UCD1K220MNL1GS
	33	8×10	0.08	26.4	1.30	130	UCD1K330MNL1GS
	47	10×10	0.08	37.6	0.70	200	UCD1K470MNL1GS
	68	12.5×13.5	0.08	54.4	0.32	500	UCD1K680MNL1MS
	100	12.5×13.5	0.08	80	0.32	500	UCD1K101MNL1MS
	150	12.5×13.5	0.08	120	0.32	500	UCD1K151MNL1MS
	330	16×16.5	0.08	264	0.17	793	UCD1K331MNL1MS
	470	18×16.5	0.08	376	0.15	917	UCD1K471MNL1MS
100 (2A)	22	8×10	0.07	22	1.30	130	UCD2A220MNL1GS
	33	10×10	0.07	33	0.70	200	UCD2A330MNL1GS
	47	12.5×13.5	0.07	47	0.32	500	UCD2A470MNL1MS
	68	12.5×13.5	0.07	68	0.32	500	UCD2A680MNL1MS
	100	16×16.5	0.07	100	0.17	793	UCD2A101MNL1MS
	150	16×16.5	0.07	150	0.17	793	UCD2A151MNL1MS
	220	18×16.5	0.07	220	0.15	917	UCD2A221MNL1MS
	330	18×16.5	0.07	330	0.15	917	UCD2A331MNL1MS

• For taping specifications, recommended land size/soldering by reflow and minimum order quantity, please refer to the Guidelines for Aluminum Electrolytic Capacitors.

ALUMINUM ELECTROLYTIC CAPACITORS

UCL Chip Type, Low Impedance

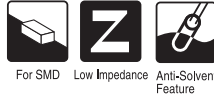

- Chip type, low impedance, temperature range up to +105°C.
- Applicable to automatic mounting machine fed with carrier tape.
- Compliant to the RoHS directive (2011/65/EU, (EU)2015/863).
- AEC-Q200 compliant. Please contact us for details.

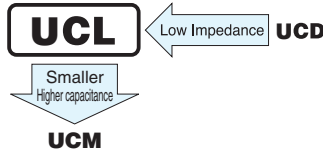

Specifications

Item	Performance Characteristics							
Category Temperature Range	- 55 to +105°C							
Rated Voltage Range	6.3 to 50V							
Rated Capacitance Range	10 to 2200µF							
Capacitance Tolerance	± 20% at 120Hz, 20°C							
Leakage Current ※	After 2 minutes' application of rated voltages at 20°C, leakage current is not more than 0.01 CV or 3 (µA), whichever is greater.							
Tangent of loss angle (tan δ)	Measurement frequency : 120Hz at 20°C							
	Rated voltage (V)	6.3	10	16	25	35	50	
Stability at Low Temperature	Measurement frequency : 120Hz							
	Rated voltage (V)	6.3	10	16	25	35	50	
	Impedance ratio ZT / Z20 (max.)	Z(-25°C) / Z(+20°C)	2	2	2	2	2	2
		Z(-40°C) / Z(+20°C)	3	3	3	3	3	3
	Z(-55°C) / Z(+20°C)	4	4	4	3	3	3	
Endurance	The specifications listed at right shall be met when the capacitors are restored to 20°C after the rated voltage is applied for 2000 hours at 105°C.		Capacitance Change		Within ± 30% of the initial capacitance value			
			tan δ		200% or less than the initial specified value			
			Leakage current		Less than or equal to the initial specified value			
Shelf Life	After storing the capacitors under no load at 105°C for 1000 hours and then performing voltage treatment based on JIS C 5101-4 clause 4.1 at 20°C, they shall meet the specified values for the endurance characteristics listed above.							
Resistance to soldering heat	The capacitors are kept on a hot plate for 30 seconds, which is maintained at 250°C. The capacitors shall meet the characteristic requirements listed at right when they are removed from the plate and restored to 20°C .		Capacitance Change		Within ± 10% of the initial capacitance value			
			tan δ		Less than or equal to the initial specified value			
			Leakage current		Less than or equal to the initial specified value			
Marking	Black print on the case top.							

※ I : Leakage Current (µA), C : Rated Capacitance (µF), V : Rated Voltage (V)

Chip Type

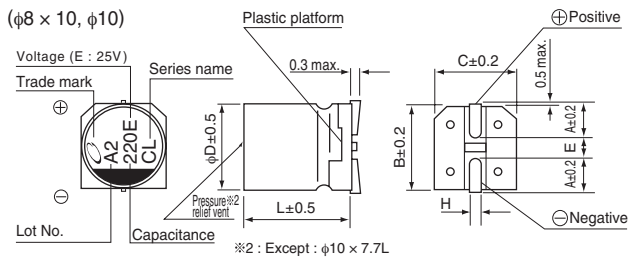
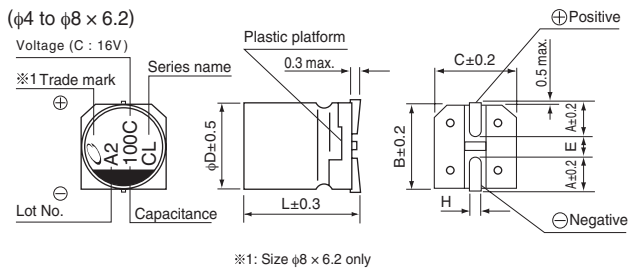

Voltage

V	6.3	10	16	25	35	50
Code	j	A	C	E	V	H

Type numbering system (Example : 16V 100µF)

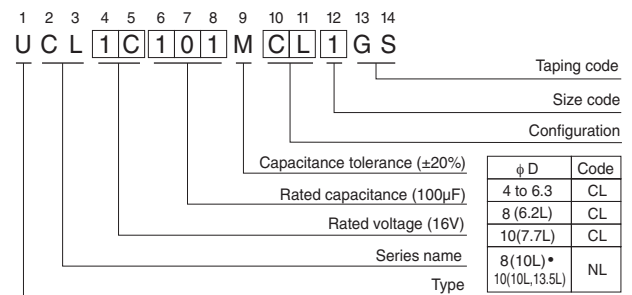

φD × L	4 × 5.8	5 × 5.8	6.3 × 5.8	6.3 × 7.7	8 × 6.2	8 × 10	10 × 7.7	10 × 10	10 × 13.5
A	1.8	2.1	2.4	2.4	3.3	2.9	3.2	3.2	3.2
B	4.3	5.3	6.6	6.6	8.3	8.3	10.3	10.3	10.3
C	4.3	5.3	6.6	6.6	8.3	8.3	10.3	10.3	10.3
E	1.0	1.3	2.2	2.2	2.3	3.1	4.5	4.5	4.5
L	5.8	5.8	5.8	7.7	6.2	10	7.7	10	13.5
H	0.5 to 0.8	0.5 to 0.8	0.5 to 0.8	0.5 to 0.8	0.5 to 0.8	0.8 to 1.1	0.8 to 1.1	0.8 to 1.1	0.8 to 1.1

Frequency coefficient of rated ripple current

Frequency	50Hz	120Hz	300Hz	1kHz	10kHz or more
Coefficient	0.35	0.50	0.64	0.83	1.00

• Dimension table in next page.



■ Dimensions

Rated Voltage (V) (code)	Rated Capacitance (μF)	Case Size φD×L (mm)	tan δ	Leakage Current (μA) (at 20°C after 2 minutes)	Impedance (Ω) max. (20°C/100kHz)	Rated Ripple (mA rms) (105°C/100kHz)	Part Number
6.3 (0J)	22	4×5.8	0.26	3	0.85	160	UCL0J220MCL1GS
	47	4×5.8	0.26	3	0.85	160	UCL0J470MCL6GS
	47	5×5.8	0.26	3	0.36	240	UCL0J470MCL1GS
	100	5×5.8	0.26	6.3	0.36	240	UCL0J101MCL6GS
	100	6.3×5.8	0.26	6.3	0.26	300	UCL0J101MCL1GS
	220	6.3×5.8	0.26	13.86	0.26	300	UCL0J221MCL1GS
	330	6.3×7.7	0.26	20.79	0.16	600	UCL0J331MCL1GS
	330	8×6.2	0.26	20.79	0.18	500	UCL0J331MCL6GS
	470	8×10	0.26	29.61	0.08	850	UCL0J471MNL1GS
	470	10×7.7	0.26	29.61	0.10	850	UCL0J471MCL6GS
	1000	8×10	0.26	63	0.08	850	UCL0J102MNL1GS
	1500	10×10	0.26	94.5	0.06	1190	UCL0J152MNL1GS
	1800	10×10	0.26	113.4	0.08	850	UCL0J182MNL1GS
	2200	10×13.5	0.26	138.6	0.06	1190	UCL0J222MNL1GS
10 (1A)	22	4×5.8	0.19	3	0.85	160	UCL1A220MCL1GS
	33	4×5.8	0.19	3.3	0.85	160	UCL1A330MCL6GS
	33	5×5.8	0.19	3.3	0.36	240	UCL1A330MCL1GS
	47	6.3×5.8	0.19	4.7	0.26	300	UCL1A470MCL1GS
	100	6.3×5.8	0.19	10	0.26	300	UCL1A101MCL1GS
	150	6.3×5.8	0.19	15	0.26	300	UCL1A151MCL1GS
	220	6.3×7.7	0.19	22	0.16	600	UCL1A221MCL1GS
	220	8×6.2	0.19	22	0.18	500	UCL1A221MCL6GS
	330	8×10	0.19	33	0.08	850	UCL1A331MNL1GS
	330	10×7.7	0.19	33	0.10	850	UCL1A331MCL6GS
	470	8×10	0.19	47	0.08	850	UCL1A471MNL1GS
	470	10×7.7	0.19	47	0.10	850	UCL1A471MCL6GS
	680	8×10	0.19	68	0.08	850	UCL1A681MNL1GS
	1000	10×10	0.19	100	0.06	1190	UCL1A102MNL1GS
	1200	10×10	0.19	120	0.08	850	UCL1A122MNL1GS
	1500	10×13.5	0.19	150	0.06	1190	UCL1A152MNL1GS
16 (1C)	10	4×5.8	0.16	3	0.85	160	UCL1C100MCL1GS
	22	4×5.8	0.16	3.52	0.85	160	UCL1C220MCL6GS
	22	5×5.8	0.16	3.52	0.36	240	UCL1C220MCL1GS
	47	5×5.8	0.16	7.52	0.36	240	UCL1C470MCL6GS
	47	6.3×5.8	0.16	7.52	0.26	300	UCL1C470MCL1GS
	68	6.3×5.8	0.16	10.88	0.26	300	UCL1C680MCL1GS
	100	6.3×5.8	0.16	16	0.26	300	UCL1C101MCL1GS
	100	6.3×7.7	0.16	16	0.16	600	UCL1C101MCL6GS
	150	6.3×7.7	0.16	24	0.16	600	UCL1C151MCL1GS
	220	6.3×7.7	0.16	35.2	0.16	600	UCL1C221MCL1GS
	220	8×6.2	0.16	35.2	0.18	500	UCL1C221MCL6GS
	330	8×10	0.16	52.8	0.08	850	UCL1C331MNL1GS
	330	10×7.7	0.16	52.8	0.10	850	UCL1C331MCL6GS
	470	8×10	0.16	75.2	0.08	850	UCL1C471MNL1GS
	470	10×7.7	0.16	75.2	0.10	850	UCL1C471MCL6GS
	680	10×10	0.16	108.8	0.06	1190	UCL1C681MNL1GS
	820	10×10	0.16	131.2	0.08	850	UCL1C821MNL1GS
	1000	10×13.5	0.16	160	0.06	1190	UCL1C102MNL1GS

UCL

■ Dimensions

Rated Voltage (V) (code)	Rated Capacitance (μF)	Case Size φD×L (mm)	tan δ	Leakage Current (μA) (at 20°C after 2 minutes)	Impedance (Ω) max. (20°C/100kHz)	Rated Ripple (mArms) (105°C/100kHz)	Part Number
25 (1E)	10	4×5.8	0.14	3	0.85	160	UCL1E100MCL1GS
	22	5×5.8	0.14	5.5	0.36	240	UCL1E220MCL1GS
	33	5×5.8	0.14	8.25	0.36	240	UCL1E330MCL6GS
	33	6.3×5.8	0.14	8.25	0.26	300	UCL1E330MCL1GS
	47	6.3×5.8	0.14	11.75	0.26	300	UCL1E470MCL1GS
	68	6.3×5.8	0.14	17	0.26	300	UCL1E680MCL1GS
	100	6.3×7.7	0.14	25	0.16	600	UCL1E101MCL1GS
	100	8×6.2	0.14	25	0.18	500	UCL1E101MCL6GS
	150	8×10	0.14	37.5	0.08	850	UCL1E151MNL1GS
	150	10×7.7	0.14	37.5	0.10	850	UCL1E151MCL6GS
	220	8×10	0.14	55	0.08	850	UCL1E221MNL1GS
	220	10×7.7	0.14	55	0.10	850	UCL1E221MCL6GS
	330	8×10	0.14	82.5	0.08	850	UCL1E331MNL1GS
	470	10×10	0.14	117.5	0.06	1190	UCL1E471MNL1GS
	560	10×10	0.14	140	0.08	850	UCL1E561MNL1GS
680	10×13.5	0.14	170	0.06	1190	UCL1E681MNL1GS	
35 (1V)	10	4×5.8	0.12	3.5	0.85	160	UCL1V100MCL6GS
	10	5×5.8	0.12	3.5	0.36	240	UCL1V100MCL1GS
	22	5×5.8	0.12	7.7	0.36	240	UCL1V220MCL1GS
	33	6.3×5.8	0.12	11.55	0.26	300	UCL1V330MCL1GS
	47	6.3×5.8	0.12	16.45	0.26	300	UCL1V470MCL1GS
	68	6.3×7.7	0.12	23.8	0.16	600	UCL1V680MCL1GS
	100	6.3×7.7	0.12	35	0.16	600	UCL1V101MCL6GS
	100	8×10	0.12	35	0.08	850	UCL1V101MNL1GS
	150	8×10	0.12	52.5	0.08	850	UCL1V151MNL1GS
	150	10×7.7	0.12	52.5	0.10	850	UCL1V151MCL6GS
	220	8×10	0.12	77	0.08	850	UCL1V221MNL1GS
	220	10×7.7	0.12	77	0.10	850	UCL1V221MCL6GS
	330	10×10	0.12	115.5	0.06	1190	UCL1V331MNL1GS
	390	10×10	0.12	136.5	0.08	850	UCL1V391MNL1GS
	470	10×13.5	0.12	164.5	0.06	1190	UCL1V471MNL1GS
50 (1H)	100	8×10	0.10	50	0.18	670	UCL1H101MNL1GS
	220	10×10	0.10	110	0.12	900	UCL1H221MNL1GS

- For taping specifications, recommended land size/soldering by reflow and minimum order quantity, please refer to the Guidelines for Aluminum Electrolytic Capacitors.

ALUMINUM ELECTROLYTIC CAPACITORS



UCM

Chip Type, Low Impedance

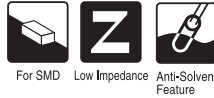

- Chip type, low impedance temperature range up to +105°C.
- Applicable to automatic mounting machine fed with carrier tape.
- Compliant to the RoHS directive (2011/65/EU, (EU)2015/863).
- AEC-Q200 compliant. Please contact us for details.

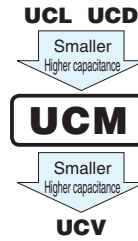

Specifications

Item	Performance Characteristics									
Category Temperature Range	-55 to +105°C									
Rated Voltage Range	6.3 to 100V									
Rated Capacitance Range	10 to 5100μF									
Capacitance Tolerance	±20% at 120Hz, 20°C									
Leakage Current ※	After 2 minutes' application of rated voltage at 20°C, leakage current is not more than 0.01 CV or 3 (μA), whichever is greater.									
Tangent of loss angle (tan δ)	Measurement frequency : 120Hz at 20°C									
	Rated voltage (V)	6.3	10	16	25	35	50	63	80	100
Stability at Low Temperature	Measurement frequency : 120Hz									
	Rated voltage (V)	6.3	10	16	25	35	50	63	80	100
	Impedance ratio Z(-25°C) / Z(+20°C)	2	2	2	2	2	2	2	2	2
Endurance	The specifications listed at right shall be met when the capacitors are restored to 20°C after the rated voltage is applied for 5000 hours (2000 hours for φD ≤ 10) at 105°C.									
	Capacitance change	Within ±30% of the initial capacitance value								
Shelf Life	After storing the capacitors under no load at 105°C for 1000 hours and then performing voltage treatment based on JIS C 5101-4 clause 4.1 at 20°C, they shall meet the specified values for the endurance characteristics listed above.									
	tan δ	200% or less than the initial specified value (For 63V or more : 300% or less than the initial specified value)								
Resistance to soldering heat	The capacitors are kept on a hot plate for 30 seconds, which is maintained at 250°C. The capacitors shall meet the characteristic requirements listed at right when they are removed from the plate and restored to 20°C.									
	Capacitance change	Within ±10% of the initial capacitance value								
Marking	Black print on the case top.									
	Leakage current	Less than or equal to the initial specified value								

※ I : Leakage Current (μA), C : Rated Capacitance (μF), V : Rated Voltage (V)

Chip Type

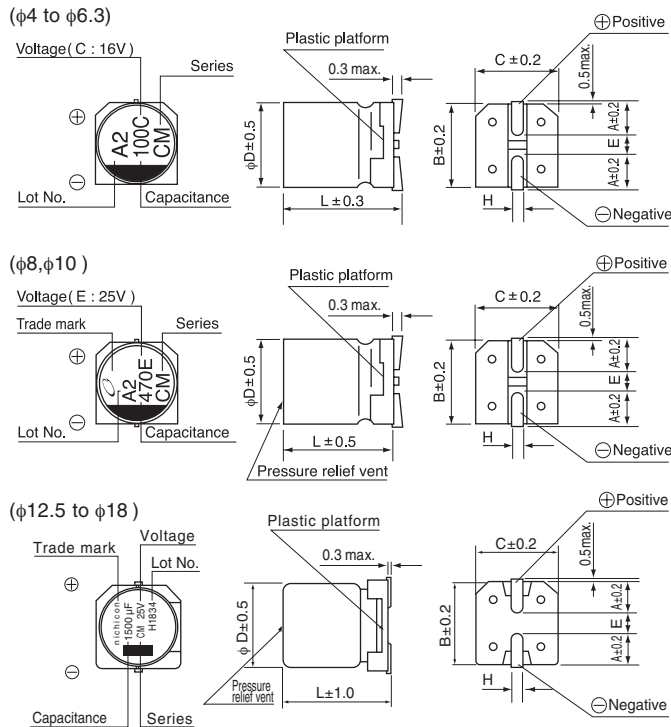

Type numbering system (Example : 25V 1500μF)

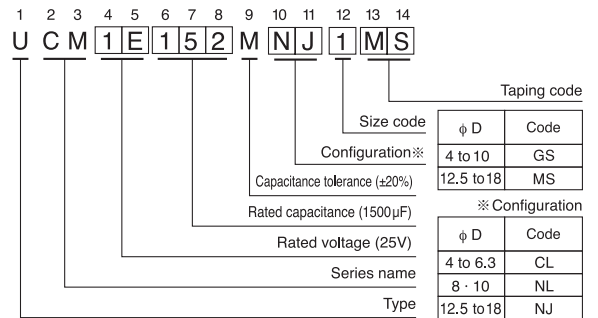

φD × L	(mm)													
	4 × 5.8	5 × 5.8	6.3 × 5.8	6.3 × 7.7	8 × 10	10 × 10	12.5 × 13.5	12.5 × 21	16 × 16.5	16 × 21.5	18 × 16.5	18 × 21.5	18 × 21.5	
A	1.8	2.1	2.4	2.4	2.9	3.2	5.15	5.15	5.65	5.65	6.65	6.65	6.65	
B	4.3	5.3	6.6	6.6	8.3	10.3	13.6	13.6	17.1	17.1	19.1	19.1	19.1	
C	4.3	5.3	6.6	6.6	8.3	10.3	13.6	13.6	17.1	17.1	19.1	19.1	19.1	
E	1	1.3	2.2	2.2	3.1	4.5	(3.3)	(3.3)	(5.8)	(5.8)	(5.8)	(5.8)	(5.8)	
L	5.8	5.8	5.8	7.7	10	10	13.5	21	16.5	21.5	16.5	21.5	21.5	
H	0.5 to 0.8	0.5 to 0.8	0.5 to 0.8	0.5 to 0.8	0.8 to 1.1	0.8 to 1.1	1.0 to 1.4	1.0 to 1.4	1.0 to 1.4	1.0 to 1.4	1.0 to 1.4	1.0 to 1.4	1.0 to 1.4	

Voltage	6.3	10	16	25	35	50	63	80	100
Code	j	A	C	E	V	H	J	K	2A

Frequency coefficient of rated ripple current

Frequency	50 Hz	120 Hz	300 Hz	1 kHz	10 kHz or more
Coefficient	0.35	0.50	0.64	0.83	1.00

● Dimension table in next page.

CAT.8100L



■ Dimensions

Rated Voltage (V) (code)	Rated Capacitance (μF)	Case Size φD×L (mm)	tan δ	Leakage Current (μA) (at 20°C after 2 minutes)	Impedance (Ω) max. (20°C/100kHz)	Rated Ripple (mArms) (105°C/100kHz)	Part Number
6.3 (0J)	100	4×5.8	0.26	6.3	1.00	160	UCM0J101MCL1GS
	220	5×5.8	0.26	13.86	0.36	240	UCM0J221MCL1GS
	330	6.3×5.8	0.26	20.79	0.26	300	UCM0J331MCL1GS
	470	6.3×7.7	0.26	29.61	0.16	600	UCM0J471MCL1GS
	680	6.3×7.7	0.26	42.84	0.16	600	UCM0J681MCL1GS
	1500	8×10	0.26	94.5	0.080	850	UCM0J152MNL1GS
	2200	10×10	0.26	138.6	0.060	1190	UCM0J222MNL1GS
10 (1A)	68	4×5.8	0.19	6.8	1.00	160	UCM1A680MCL1GS
	150	5×5.8	0.19	15	0.36	240	UCM1A151MCL1GS
	220	6.3×5.8	0.19	22	0.26	300	UCM1A221MCL1GS
	330	6.3×7.7	0.19	33	0.16	600	UCM1A331MCL1GS
	470	6.3×7.7	0.19	47	0.16	600	UCM1A471MCL1GS
	1000	8×10	0.19	100	0.080	850	UCM1A102MNL1GS
	1500	10×10	0.19	150	0.060	1190	UCM1A152MNL1GS
16 (1C)	47	4×5.8	0.16	7.52	1.00	160	UCM1C470MCL1GS
	68	5×5.8	0.16	10.88	0.36	240	UCM1C680MCL1GS
	100	5×5.8	0.16	16	0.36	240	UCM1C101MCL1GS
	150	6.3×5.8	0.16	24	0.26	300	UCM1C151MCL1GS
	220	6.3×5.8	0.16	35.2	0.26	300	UCM1C221MCL1GS
	330	6.3×7.7	0.16	52.8	0.16	600	UCM1C331MCL1GS
	680	8×10	0.16	108.8	0.080	850	UCM1C681MNL1GS
	1000	10×10	0.16	160	0.060	1190	UCM1C102MNL1GS
25 (1E)	22	4×5.8	0.14	5.5	1.00	160	UCM1E220MCL1GS
	33	4×5.8	0.14	8.25	1.00	160	UCM1E330MCL1GS
	47	5×5.8	0.14	11.75	0.36	240	UCM1E470MCL1GS
	68	5×5.8	0.14	17	0.36	240	UCM1E680MCL1GS
	100	6.3×5.8	0.14	25	0.26	300	UCM1E101MCL1GS
	150	6.3×7.7	0.14	37.5	0.16	600	UCM1E151MCL1GS
	220	6.3×7.7	0.14	55	0.16	600	UCM1E221MCL1GS
	470	8×10	0.14	117.5	0.080	850	UCM1E471MNL1GS
	820	10×10	0.14	205	0.060	1190	UCM1E821MNL1GS
	1500	12.5×13.5	0.14	375	0.058	1420	UCM1E152MNJ1MS
	2400	12.5×21	0.16	600	0.046	2080	UCM1E242MNJ1MS
	2700	16×16.5	0.16	675	0.047	1910	UCM1E272MNJ1MS
	3600	18×16.5	0.18	900	0.045	2060	UCM1E362MNJ1MS
	3900	16×21.5	0.18	975	0.034	2540	UCM1E392MNJ1MS
5100	18×21.5	0.22	1275	0.032	2640	UCM1E512MNJ1MS	
35 (1V)	22	4×5.8	0.12	7.7	1.00	160	UCM1V220MCL1GS
	33	5×5.8	0.12	11.55	0.36	240	UCM1V330MCL1GS
	47	5×5.8	0.12	16.45	0.36	240	UCM1V470MCL1GS
	68	6.3×5.8	0.12	23.8	0.26	300	UCM1V680MCL1GS
	100	6.3×5.8	0.12	35	0.26	300	UCM1V101MCL1GS
	150	6.3×7.7	0.12	52.5	0.16	600	UCM1V151MCL1GS
	330	8×10	0.12	115.5	0.080	850	UCM1V331MNL1GS
	560	10×10	0.12	196	0.060	1190	UCM1V561MNL1GS
	910	12.5×13.5	0.12	318.5	0.058	1420	UCM1V911MNJ1MS
	1600	12.5×21	0.12	560	0.046	2080	UCM1V162MNJ1MS
	1800	16×16.5	0.12	630	0.047	1910	UCM1V182MNJ1MS
	2200	18×16.5	0.14	770	0.045	2060	UCM1V222MNJ1MS
	2700	16×21.5	0.14	945	0.034	2540	UCM1V272MNJ1MS
	3600	18×21.5	0.16	1260	0.032	2640	UCM1V362MNJ1MS

UCM

■ Dimensions

Rated Voltage (V) (code)	Rated Capacitance (μF)	Case Size φD×L (mm)	tan δ	Leakage Current (μA) (at 20°C after 2 minutes)	Impedance (Ω) max. (20°C/100kHz)	Rated Ripple (mArms) (105°C/100kHz)	Part Number
50 (1H)	10	4×5.8	0.10	5	2.30	85	UCM1H100MCL6GS
	10	5×5.8	0.10	5	0.88	165	UCM1H100MCL1GS
	22	5×5.8	0.10	11	0.88	165	UCM1H220MCL1GS
	47	6.3×5.8	0.10	23.5	0.68	195	UCM1H470MCL1GS
	100	6.3×7.7	0.10	50	0.34	350	UCM1H101MCL1GS
	220	8×10	0.10	110	0.18	670	UCM1H221MNL1GS
	330	10×10	0.10	165	0.12	900	UCM1H331MNL1GS
	470	12.5×13.5	0.10	235	0.12	1340	UCM1H471MNL1GS
	750	12.5×21	0.10	375	0.080	1970	UCM1H751MNL1GS
	820	16×16.5	0.10	410	0.080	1820	UCM1H821MNL1GS
	1100	18×16.5	0.10	550	0.078	1980	UCM1H112MNL1GS
	1200	16×21.5	0.10	600	0.050	2440	UCM1H122MNL1GS
1600	18×21.5	0.10	800	0.050	2550	UCM1H162MNL1GS	
63 (1J)	47	6.3×7.7	0.08	29.61	0.80	190	UCM1J470MCL1GS
	100	8×10	0.08	63	0.40	300	UCM1J101MNL1GS
	220	10×10	0.08	138.6	0.25	500	UCM1J221MNL1GS
	360	12.5×13.5	0.08	226.8	0.14	1250	UCM1J361MNL1GS
	560	12.5×21	0.08	352.8	0.086	1850	UCM1J561MNL1GS
	620	16×16.5	0.08	390.6	0.082	1740	UCM1J621MNL1GS
	820	18×16.5	0.08	516.6	0.080	1880	UCM1J821MNL1GS
	910	16×21.5	0.08	573.3	0.055	2330	UCM1J911MNL1GS
	1200	18×21.5	0.08	756	0.054	2430	UCM1J122MNL1GS
80 (1K)	33	6.3×7.7	0.08	26.4	0.80	190	UCM1K330MCL1GS
	68	8×10	0.08	54.4	0.40	300	UCM1K680MNL1GS
	100	10×10	0.08	80	0.25	500	UCM1K101MNL1GS
	220	12.5×13.5	0.08	176	0.18	1050	UCM1K221MNL1GS
	360	12.5×21	0.08	288	0.11	1580	UCM1K361MNL1GS
	390	16×16.5	0.08	312	0.10	1500	UCM1K391MNL1GS
	510	18×16.5	0.08	408	0.098	1670	UCM1K511MNL1GS
	560	16×21.5	0.08	448	0.066	2040	UCM1K561MNL1GS
	750	18×21.5	0.08	600	0.063	2140	UCM1K751MNL1GS
100 (2A)	130	12.5×13.5	0.07	130	0.18	1050	UCM2A131MNL1GS
	220	12.5×21	0.07	220	0.11	1580	UCM2A221MNL1GS
	240	16×16.5	0.07	240	0.10	1500	UCM2A241MNL1GS
	330	18×16.5	0.07	330	0.098	1670	UCM2A331MNL1GS
	390	16×21.5	0.07	390	0.066	2040	UCM2A391MNL1GS
	510	18×21.5	0.07	510	0.063	2140	UCM2A511MNL1GS

- For taping specifications, recommended land size/soldering by reflow and minimum order quantity, please refer to the Guidelines for Aluminum Electrolytic Capacitors.

ALUMINUM ELECTROLYTIC CAPACITORS

UCV

Chip Type, Low Impedance.



- Chip type, low impedance temperature range up to +105°C.
- Applicable to automatic mounting machine fed with carrier tape.
- Compliant to the RoHS directive (2011/65/EU, (EU)2015/863).
- AEC-Q200 compliant. Please contact us for details.

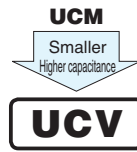

Specifications

Item	Performance Characteristics	
Category Temperature Range	-55 to +105°C	
Rated Voltage Range	16 to 35V	
Rated Capacitance Range	220 to 1500μF	
Capacitance Tolerance	±20% at 120Hz, 20°C	
Leakage Current ※	After 2 minutes' application of rated voltage at 20°C, leakage current is not more than 0.01CV (μA).	
Tangent of loss angle (tan δ)	Rated voltage (V)	16 25 35
	tan δ (max.)	0.16 0.14 0.12
Stability at Low Temperature	Rated voltage (V)	16 25 35
	Impedance ratio Z(-25°C) / Z(+20°C)	2 2 2
	Z(-40°C) / Z(+20°C)	3 3 3
	Z(-55°C) / Z(+20°C)	4 3 3
Endurance	Capacitance change	Within ±30% of the initial capacitance value
	tan δ	200% or less than the initial specified value
	Leakage current	Less than or equal to the initial specified value
Shelf Life	After storing the capacitors under no load at 105°C for 1000 hours and then performing voltage treatment based on JIS C 5101-4 clause 4.1 at 20°C, they shall meet the specified values for the endurance characteristics listed above.	
Resistance to soldering heat	Capacitance change	Within ±10% of the initial capacitance value
	tan δ	Less than or equal to the initial specified value
	Leakage current	Less than or equal to the initial specified value
Marking	Black print on the case top.	

※ I : Leakage Current (μA), C : Rated Capacitance (μF), V : Rated Voltage (V)

Chip Type (φ 6.3)

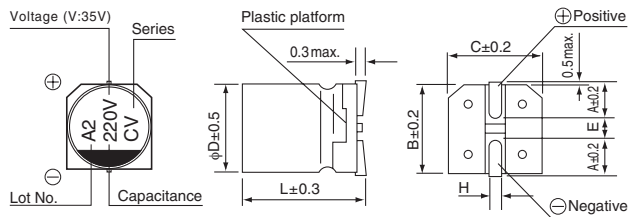

(φ 8, φ10)

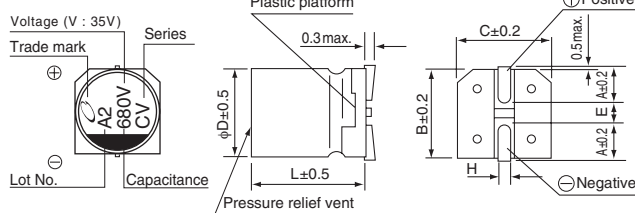

Type numbering system (Example : 35V 220μF)

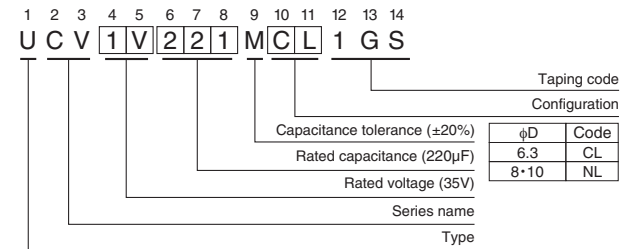

Voltage	16	25	35
Code	C	E	V

Standard	(mm)		
	φD×L	6.3×7.7	8×10
A	2.4	2.9	3.2
B	6.6	8.3	10.3
C	6.6	8.3	10.3
E	2.2	3.1	4.5
L	7.7	10	10
H	0.5 to 0.8	0.8 to 1.1	0.8 to 1.1

Frequency coefficient of rated ripple current

Frequency	50Hz	120Hz	300Hz	1kHz	10kHz or more
Coefficient	0.35	0.50	0.64	0.83	1.00

● Dimension table in next page.

UCV

■ Dimensions

Rated Voltage (V) (code)	Rated Capacitance (μF)	Case Size φD×L (mm)	tan δ	Leakage Current (μA) (at 20°C after 2 minutes)	Impedance (Ω) max. (20°C/100kHz)	Rated Ripple (mArms) (105°C/100kHz)	Part Number
16 (1C)	470	6.3×7.7	0.16	75.2	0.16	600	UCV1C471MCL1GS
	820	8×10	0.16	131.2	0.08	850	UCV1C821MNL1GS
	1500	10×10	0.16	240	0.06	1190	UCV1C152MNL1GS
25 (1E)	330	6.3×7.7	0.14	82.5	0.16	600	UCV1E331MCL1GS
	560	8×10	0.14	140	0.08	850	UCV1E561MNL1GS
	1000	10×10	0.14	250	0.06	1190	UCV1E102MNL1GS
35 (1V)	220	6.3×7.7	0.12	77	0.16	600	UCV1V221MCL1GS
	470	8×10	0.12	164.5	0.08	850	UCV1V471MNL1GS
	680	10×10	0.12	238	0.06	1190	UCV1V681MNL1GS

• For taping specifications, recommended land size/soldering by reflow and minimum order quantity, please refer to the Guidelines for Aluminum Electrolytic Capacitors.

ALUMINUM ELECTROLYTIC CAPACITORS

UUD

Chip Type, Low Impedance

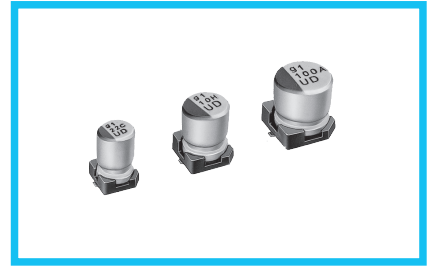

- Chip type, low impedance temperature range up to +105°C.
- Designed for surface mounting on high density PC board.
- Applicable to automatic mounting machine fed with carrier tape.
- Compliant to the RoHS directive (2011/65/EU,(EU)2015/863).
- AEC-Q200 compliant. Please contact us for details.

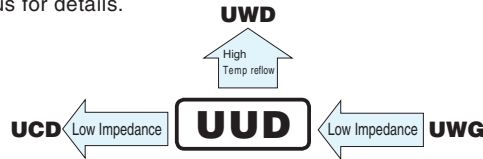

Specifications

Item	Performance Characteristics						
Category Temperature Range	-55 to +105°C						
Rated Voltage Range	6.3 to 50V						
Rated Capacitance Range	1 to 1500μF						
Capacitance Tolerance	±20% at 120Hz, 20°C						
Leakage Current ※	After 2 minutes' application of rated voltage at 20°C, leakage current is not more than 0.01 CV or 3 (μA), whichever is greater.						
Tangent of loss angle (tan δ)	Measurement frequency : 120Hz at 20°C						
	Rated voltage (V)	6.3	10	16	25	35	50
Stability at Low Temperature	Measurement frequency : 120Hz						
	Impedance ratio	Z(-25°C) / Z(+20°C)	3	2	2	2	2
Endurance	The specifications listed at right shall be met when the capacitors are restored to 20°C after the rated voltage is applied for 5000 hours (2000 hours for φD = 4, 5 and 6.3) at 105°C.						
	Capacitance change	Within ±30% of the initial capacitance value					
Shelf Life	After storing the capacitors under no load at 105°C for 1000 hours and then performing voltage treatment based on JIS C 5101-4 clause 4.1 at 20°C, they shall meet the specified values for the endurance characteristics listed above.						
	tan δ	200% or less than the initial specified value					
Resistance to soldering heat	The capacitors are kept on a hot plate for 30 seconds, which is maintained at 250°C. The capacitors shall meet the characteristic requirements listed at right when they are removed from the plate and restored to 20°C.						
	Leakage current	Less than or equal to the initial specified value					
Marking	Black print on the case top.						

※ I : Leakage Current (μA), C : Rated Capacitance (μF), V : Rated Voltage (V)

Chip Type

(φ4 to φ6.3)

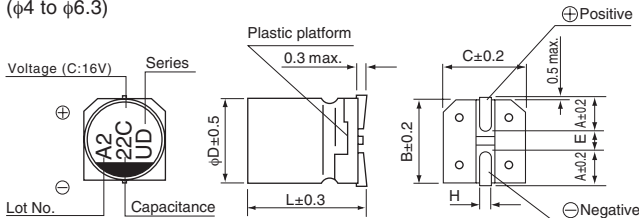

(φ8, φ10)

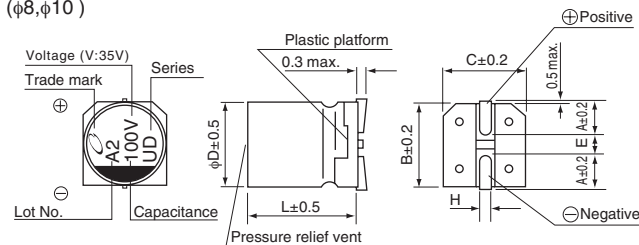

Type numbering system (Example : 16V 22μF)

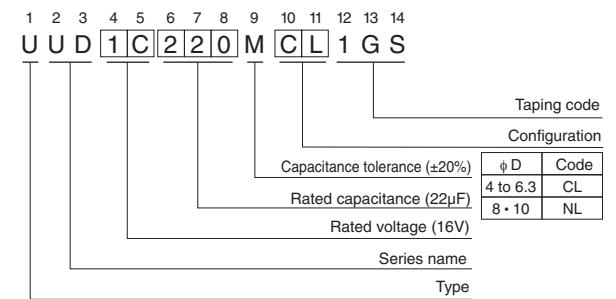

φD × L	4 × 5.8	5 × 5.8	6.3 × 5.8	6.3 × 7.7	8 × 10	10 × 10
A	1.8	2.1	2.4	2.4	2.9	3.2
B	4.3	5.3	6.6	6.6	8.3	10.3
C	4.3	5.3	6.6	6.6	8.3	10.3
E	1.0	1.3	2.2	2.2	3.1	4.5
L	5.8	5.8	5.8	7.7	10	10
H	0.5 to 0.8	0.5 to 0.8	0.5 to 0.8	0.5 to 0.8	0.8 to 1.1	0.8 to 1.1

Voltage

V	6.3	10	16	25	35	50
Code	j	A	C	E	V	H

● Dimension table in next page.

Frequency coefficient of rated ripple current

Frequency	50 Hz	120 Hz	300 Hz	1 kHz	10 kHz or more
Coefficient	0.35	0.50	0.64	0.83	1.00

UUD

■ Dimensions

Rated Voltage (V) (code)	Rated Capacitance (μF)	Case Size φD×L (mm)	tan δ	Leakage Current (μA) (at 20°C after 2 minutes)	Impedance (Ω) max. (20°C/100kHz)	Rated Ripple (mA rms) (105°C/100kHz)	Part Number
6.3 (0J)	27	4×5.8	0.26	3	1.80	80	UUD0J270MCL1GS
	33	5×5.8	0.26	3	0.76	150	UUD0J330MCL1GS
	47	5×5.8	0.26	3	0.76	150	UUD0J470MCL1GS
	56	5×5.8	0.26	3.528	0.76	150	UUD0J560MCL1GS
	68	6.3×5.8	0.26	4.284	0.44	230	UUD0J680MCL1GS
	100	6.3×5.8	0.26	6.3	0.44	230	UUD0J101MCL1GS
	150	6.3×5.8	0.26	9.45	0.44	230	UUD0J151MCL1GS
	220	6.3×5.8	0.26	13.86	0.44	230	UUD0J221MCL1GS
	330	6.3×7.7	0.26	20.79	0.34	280	UUD0J331MCL1GS
	470	8×10	0.28	29.61	0.17	450	UUD0J471MNL1GS
	680	8×10	0.28	42.84	0.17	450	UUD0J681MNL1GS
	1000	8×10	0.28	63	0.17	450	UUD0J102MNL1GS
	1500	10×10	0.28	94.5	0.09	670	UUD0J152MNL1GS
10 (1A)	22	4×5.8	0.20	3	1.80	80	UUD1A220MCL1GS
	27	5×5.8	0.20	3	0.76	150	UUD1A270MCL1GS
	33	5×5.8	0.20	3.3	0.76	150	UUD1A330MCL1GS
	47	6.3×5.8	0.20	4.7	0.44	230	UUD1A470MCL1GS
	56	6.3×5.8	0.20	5.6	0.44	230	UUD1A560MCL1GS
	68	6.3×5.8	0.20	6.8	0.44	230	UUD1A680MCL1GS
	100	6.3×5.8	0.20	10	0.44	230	UUD1A101MCL1GS
	150	6.3×5.8	0.20	15	0.44	230	UUD1A151MCL1GS
	220	6.3×7.7	0.20	22	0.34	280	UUD1A221MCL1GS
	330	8×10	0.24	33	0.17	450	UUD1A331MNL1GS
	470	8×10	0.24	47	0.17	450	UUD1A471MNL1GS
	680	10×10	0.24	68	0.09	670	UUD1A681MNL1GS
	1000	10×10	0.24	100	0.09	670	UUD1A102MNL1GS
16 (1C)	15	4×5.8	0.16	3	1.80	80	UUD1C150MCL1GS
	22	5×5.8	0.16	3.52	0.76	150	UUD1C220MCL1GS
	27	5×5.8	0.16	4.32	0.76	150	UUD1C270MCL1GS
	33	6.3×5.8	0.16	5.28	0.44	230	UUD1C330MCL1GS
	47	6.3×5.8	0.16	7.52	0.44	230	UUD1C470MCL1GS
	56	6.3×5.8	0.16	8.96	0.44	230	UUD1C560MCL1GS
	68	6.3×5.8	0.16	10.88	0.44	230	UUD1C680MCL1GS
	100	6.3×5.8	0.16	16	0.44	230	UUD1C101MCL1GS
	150	6.3×7.7	0.16	24	0.34	280	UUD1C151MCL1GS
	220	6.3×7.7	0.16	35.2	0.34	280	UUD1C221MCL1GS
	330	8×10	0.20	52.8	0.17	450	UUD1C331MNL1GS
	470	8×10	0.20	75.2	0.17	450	UUD1C471MNL1GS
	680	10×10	0.20	108.8	0.09	670	UUD1C681MNL1GS

UUD

■ Dimensions

Rated Voltage (V) (code)	Rated Capacitance (μF)	Case Size φD×L (mm)	tan δ	Leakage Current (μA) (at 20°C after 2 minutes)	Impedance (Ω) max. (20°C/100kHz)	Rated Ripple (mArms) (105°C/100kHz)	Part Number
25 (1E)	10	4×5.8	0.14	3	1.80	80	UUD1E100MCL1GS
	15	5×5.8	0.14	3.75	0.76	150	UUD1E150MCL1GS
	22	5×5.8	0.14	5.5	0.76	150	UUD1E220MCL1GS
	27	6.3×5.8	0.14	6.75	0.44	230	UUD1E270MCL1GS
	33	6.3×5.8	0.14	8.25	0.44	230	UUD1E330MCL1GS
	47	6.3×5.8	0.14	11.75	0.44	230	UUD1E470MCL1GS
	56	6.3×5.8	0.14	14	0.44	230	UUD1E560MCL1GS
	68	6.3×5.8	0.14	17	0.44	230	UUD1E680MCL1GS
	100	6.3×7.7	0.14	25	0.34	280	UUD1E101MCL1GS
	150	8×10	0.16	37.5	0.17	450	UUD1E151MNL1GS
	220	8×10	0.16	55	0.17	450	UUD1E221MNL1GS
	330	8×10	0.16	82.5	0.17	450	UUD1E331MNL1GS
	470	10×10	0.16	117.5	0.09	670	UUD1E471MNL1GS
35 (1V)	4.7	4×5.8	0.12	3	1.80	80	UUD1V47MCL1GS
	10	5×5.8	0.12	3.5	0.76	150	UUD1V100MCL1GS
	15	5×5.8	0.12	5.25	0.76	150	UUD1V150MCL1GS
	22	5×5.8	0.12	7.7	0.76	150	UUD1V220MCL1GS
	27	6.3×5.8	0.12	9.45	0.44	230	UUD1V270MCL1GS
	33	6.3×5.8	0.12	11.55	0.44	230	UUD1V330MCL1GS
	47	6.3×5.8	0.12	16.45	0.44	230	UUD1V470MCL1GS
	56	6.3×7.7	0.12	19.6	0.34	280	UUD1V560MCL1GS
	68	6.3×7.7	0.12	23.8	0.34	280	UUD1V680MCL1GS
	100	8×10	0.14	35	0.17	450	UUD1V101MNL1GS
	150	8×10	0.14	52.5	0.17	450	UUD1V151MNL1GS
	220	8×10	0.14	77	0.17	450	UUD1V221MNL1GS
	330	10×10	0.14	115.5	0.09	670	UUD1V331MNL1GS
50 (1H)	1	4×5.8	0.12	3	5.00	30	UUD1H010MCL1GS
	2.2	4×5.8	0.12	3	5.00	30	UUD1H2R2MCL1GS
	3.3	4×5.8	0.12	3	5.00	30	UUD1H3R3MCL1GS
	4.7	5×5.8	0.12	3	1.52	85	UUD1H47MCL1GS
	10	6.3×5.8	0.12	5	0.88	165	UUD1H100MCL1GS
	15	6.3×5.8	0.12	7.5	0.88	165	UUD1H150MCL1GS
	22	6.3×5.8	0.12	11	0.88	165	UUD1H220MCL1GS
	27	6.3×7.7	0.12	13.5	0.68	185	UUD1H270MCL1GS
	33	6.3×7.7	0.12	16.5	0.68	185	UUD1H330MCL1GS
	47	6.3×7.7	0.12	23.5	0.68	185	UUD1H470MCL1GS
	56	8×10	0.14	28	0.34	300	UUD1H560MNL1GS
	68	8×10	0.14	34	0.34	300	UUD1H680MNL1GS
	100	8×10	0.14	50	0.34	300	UUD1H101MNL1GS
	150	10×10	0.14	75	0.18	670	UUD1H151MNL1GS
220	10×10	0.14	110	0.18	670	UUD1H221MNL1GS	

• For taping specifications, recommended land size/soldering by reflow and minimum order quantity, please refer to the Guidelines for Aluminum Electrolytic Capacitors.

ALUMINUM ELECTROLYTIC CAPACITORS

UWD

Chip Type, Low Impedance
High Temperature (260°C) Reflow

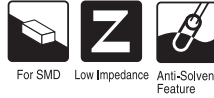

- Corresponding with 260°C peak reflow soldering
Recommended reflow condition : 260°C peak 5 sec. 230°C over 60 sec.
2 times ($\phi 10 \times 10$: 1 time)
- Chip type, low impedance temperature range up to +105°C.
- Designed for surface mounting on high density PC board.
- Applicable to automatic mounting machine fed with carrier tape.
- Compliant to the RoHS directive (2011/65/EU,(EU)2015/863).
- AEC-Q200 compliant. Please contact us for details.

UWD

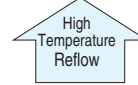

UUD



Specifications

Item	Performance Characteristics																						
Category Temperature Range	-55 to +105°C																						
Rated Voltage Range	6.3 to 50V																						
Rated Capacitance Range	1 to 1500 μ F																						
Capacitance Tolerance	$\pm 20\%$ at 120Hz, 20°C																						
Leakage Current ※	After 2 minutes' application of rated voltage at 20°C, leakage current is not more than 0.01 CV or 3 (μ A), whichever is greater.																						
Tangent of loss angle (tan δ)	<p>Measurement frequency : 120Hz at 20°C</p> <table border="1"> <tr> <td>Rated voltage (V)</td> <td>6.3</td> <td>10</td> <td>16</td> <td>25</td> <td>35</td> <td>50</td> </tr> <tr> <td>tan δ (max.)</td> <td>0.26 (0.28)</td> <td>0.20 (0.24)</td> <td>0.16 (0.20)</td> <td>0.14 (0.16)</td> <td>0.12 (0.14)</td> <td>0.12 (0.14)</td> </tr> </table> <p>() is $\phi 8$ over</p>	Rated voltage (V)	6.3	10	16	25	35	50	tan δ (max.)	0.26 (0.28)	0.20 (0.24)	0.16 (0.20)	0.14 (0.16)	0.12 (0.14)	0.12 (0.14)								
Rated voltage (V)	6.3	10	16	25	35	50																	
tan δ (max.)	0.26 (0.28)	0.20 (0.24)	0.16 (0.20)	0.14 (0.16)	0.12 (0.14)	0.12 (0.14)																	
Stability at Low Temperature	<p>Measurement frequency : 120Hz</p> <table border="1"> <tr> <td>Rated voltage (V)</td> <td>6.3</td> <td>10</td> <td>16</td> <td>25</td> <td>35</td> <td>50</td> </tr> <tr> <td>Impedance ratio Z(-25°C) / Z(+20°C)</td> <td>3</td> <td>2</td> <td>2</td> <td>2</td> <td>2</td> <td>2</td> </tr> <tr> <td>ZT / Z20 (max.)</td> <td>Z(-55°C) / Z(+20°C)</td> <td>5</td> <td>4</td> <td>4</td> <td>3</td> <td>3</td> <td>3</td> </tr> </table>	Rated voltage (V)	6.3	10	16	25	35	50	Impedance ratio Z(-25°C) / Z(+20°C)	3	2	2	2	2	2	ZT / Z20 (max.)	Z(-55°C) / Z(+20°C)	5	4	4	3	3	3
Rated voltage (V)	6.3	10	16	25	35	50																	
Impedance ratio Z(-25°C) / Z(+20°C)	3	2	2	2	2	2																	
ZT / Z20 (max.)	Z(-55°C) / Z(+20°C)	5	4	4	3	3	3																
Endurance	<p>The specifications listed at right shall be met when the capacitors are restored to 20°C after the rated voltage is applied for 5000 hours (2000 hours for $\phi D = 4, 5$ and 6.3) at 105°C.</p> <table border="1"> <tr> <td>Capacitance change</td> <td>Within $\pm 30\%$ of the initial capacitance value</td> </tr> <tr> <td>tan δ</td> <td>200% or less than the initial specified value</td> </tr> <tr> <td>Leakage current</td> <td>Less than or equal to the initial specified value</td> </tr> </table>	Capacitance change	Within $\pm 30\%$ of the initial capacitance value	tan δ	200% or less than the initial specified value	Leakage current	Less than or equal to the initial specified value																
Capacitance change	Within $\pm 30\%$ of the initial capacitance value																						
tan δ	200% or less than the initial specified value																						
Leakage current	Less than or equal to the initial specified value																						
Shelf Life	After storing the capacitors under no load at 105°C for 1000 hours and then performing voltage treatment based on JIS C 5101-4 clause 4.1 at 20°C, they shall meet the specified values for the endurance characteristics listed above.																						
Resistance to soldering heat	<p>The capacitors are kept on a hot plate for 30 seconds, which is maintained at 250°C. The capacitors shall meet the characteristic requirements listed at right when they are removed from the plate and restored to 20°C.</p> <table border="1"> <tr> <td>Capacitance change</td> <td>Within $\pm 10\%$ of the initial capacitance value</td> </tr> <tr> <td>tan δ</td> <td>Less than or equal to the initial specified value</td> </tr> <tr> <td>Leakage current</td> <td>Less than or equal to the initial specified value</td> </tr> </table>	Capacitance change	Within $\pm 10\%$ of the initial capacitance value	tan δ	Less than or equal to the initial specified value	Leakage current	Less than or equal to the initial specified value																
Capacitance change	Within $\pm 10\%$ of the initial capacitance value																						
tan δ	Less than or equal to the initial specified value																						
Leakage current	Less than or equal to the initial specified value																						
Marking	Black print on the case top.																						

※ I : Leakage Current (μ A), C : Rated Capacitance (μ F), V : Rated Voltage (V)

Chip Type

($\phi 4$ to $\phi 6.3$)

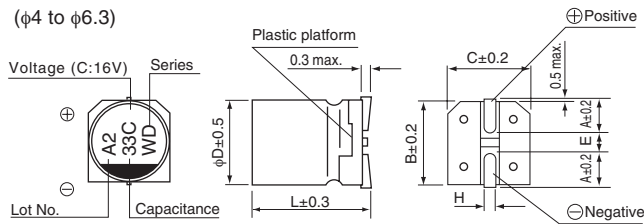

($\phi 8, \phi 10$)

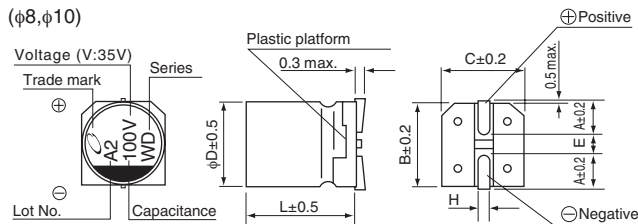

Type numbering system (Example : 16V 22 μ F)

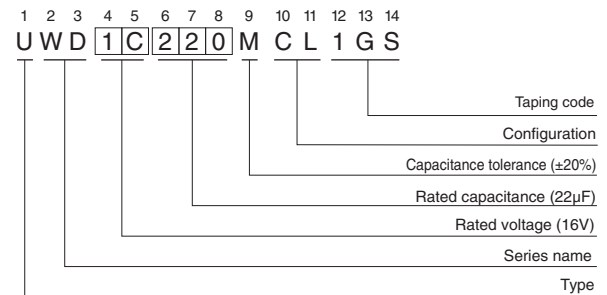

$\phi D \times L$	4 × 5.8	5 × 5.8	6.3 × 5.8	6.3 × 7.7	8 × 10	10 × 10
A	1.8	2.1	2.4	2.4	2.9	3.2
B	4.3	5.3	6.6	6.6	8.3	10.3
C	4.3	5.3	6.6	6.6	8.3	10.3
E	1.0	1.3	2.2	2.2	3.1	4.5
L	5.8	5.8	5.8	7.7	10	10
H	0.5 to 0.8	0.5 to 0.8	0.5 to 0.8	0.5 to 0.8	0.8 to 1.1	0.8 to 1.1

Voltage

V	6.3	10	16	25	35	50
Code	j	A	C	E	V	H

Frequency coefficient of rated ripple current

Frequency	50 Hz	120 Hz	300 Hz	1 kHz	10 kHz or more
Coefficient	0.35	0.50	0.64	0.83	1.00

● Dimension table in next page.

UWD

■ Dimensions

Rated Voltage (V) (code)	Rated Capacitance (μF)	Case Size φD×L (mm)	tan δ	Leakage Current (μA) (at 20°C after 2 minutes)	Impedance (Ω) max. (20°C/100kHz)	Rated Ripple (mArms) (105°C/100kHz)	Part Number
6.3 (0J)	27	4×5.8	0.26	3	1.80	80	UWD0J270MCL1GS
	33	5×5.8	0.26	3	0.76	150	UWD0J330MCL1GS
	47	5×5.8	0.26	3	0.76	150	UWD0J470MCL1GS
	56	5×5.8	0.26	3.528	0.76	150	UWD0J560MCL1GS
	68	6.3×5.8	0.26	4.284	0.44	230	UWD0J680MCL1GS
	100	6.3×5.8	0.26	6.3	0.44	230	UWD0J101MCL1GS
	150	6.3×5.8	0.26	9.45	0.44	230	UWD0J151MCL1GS
	220	6.3×5.8	0.26	13.86	0.44	230	UWD0J221MCL1GS
	330	6.3×7.7	0.26	20.79	0.34	280	UWD0J331MCL1GS
	470	8×10	0.28	29.61	0.17	450	UWD0J471MCL1GS
	680	8×10	0.28	42.84	0.17	450	UWD0J681MCL1GS
	1000	10×10	0.28	63	0.09	670	UWD0J102MCL1GS
	1500	10×10	0.28	94.5	0.09	670	UWD0J152MCL1GS
10 (1A)	22	4×5.8	0.20	3	1.80	80	UWD1A220MCL1GS
	27	5×5.8	0.20	3	0.76	150	UWD1A270MCL1GS
	33	5×5.8	0.20	3.3	0.76	150	UWD1A330MCL1GS
	47	6.3×5.8	0.20	4.7	0.44	230	UWD1A470MCL1GS
	56	6.3×5.8	0.20	5.6	0.44	230	UWD1A560MCL1GS
	68	6.3×5.8	0.20	6.8	0.44	230	UWD1A680MCL1GS
	100	6.3×5.8	0.20	10	0.44	230	UWD1A101MCL1GS
	150	6.3×5.8	0.20	15	0.44	230	UWD1A151MCL1GS
	220	6.3×7.7	0.20	22	0.34	280	UWD1A221MCL1GS
	330	8×10	0.24	33	0.17	450	UWD1A331MCL1GS
	470	8×10	0.24	47	0.17	450	UWD1A471MCL1GS
	680	10×10	0.24	68	0.09	670	UWD1A681MCL1GS
	1000	10×10	0.24	100	0.09	670	UWD1A102MCL1GS
16 (1C)	15	4×5.8	0.16	3	1.80	80	UWD1C150MCL1GS
	22	5×5.8	0.16	3.52	0.76	150	UWD1C220MCL1GS
	27	5×5.8	0.16	4.32	0.76	150	UWD1C270MCL1GS
	33	6.3×5.8	0.16	5.28	0.44	230	UWD1C330MCL1GS
	47	6.3×5.8	0.16	7.52	0.44	230	UWD1C470MCL1GS
	56	6.3×5.8	0.16	8.96	0.44	230	UWD1C560MCL1GS
	68	6.3×5.8	0.16	10.88	0.44	230	UWD1C680MCL1GS
	100	6.3×5.8	0.16	16	0.44	230	UWD1C101MCL1GS
	150	6.3×7.7	0.16	24	0.34	280	UWD1C151MCL1GS
	220	6.3×7.7	0.16	35.2	0.34	280	UWD1C221MCL1GS
	330	8×10	0.20	52.8	0.17	450	UWD1C331MCL1GS
	470	8×10	0.20	75.2	0.17	450	UWD1C471MCL1GS
	680	10×10	0.20	108.8	0.09	670	UWD1C681MCL1GS

UWD

■ Dimensions

Rated Voltage (V) (code)	Rated Capacitance (μF)	Case Size φD×L (mm)	tan δ	Leakage Current (μA) (at 20°C after 2 minutes)	Impedance (Ω) max. (20°C/100kHz)	Rated Ripple (mArms) (105°C/100kHz)	Part Number
25 (1E)	10	4×5.8	0.14	3	1.80	80	UWD1E100MCL1GS
	15	5×5.8	0.14	3.75	0.76	150	UWD1E150MCL1GS
	22	5×5.8	0.14	5.5	0.76	150	UWD1E220MCL1GS
	27	6.3×5.8	0.14	6.75	0.44	230	UWD1E270MCL1GS
	33	6.3×5.8	0.14	8.25	0.44	230	UWD1E330MCL1GS
	47	6.3×5.8	0.14	11.75	0.44	230	UWD1E470MCL1GS
	56	6.3×5.8	0.14	14	0.44	230	UWD1E560MCL1GS
	68	6.3×5.8	0.14	17	0.44	230	UWD1E680MCL1GS
	100	6.3×7.7	0.14	25	0.34	280	UWD1E101MCL1GS
	150	8×10	0.16	37.5	0.17	450	UWD1E151MCL1GS
	220	8×10	0.16	55	0.17	450	UWD1E221MCL1GS
	330	10×10	0.16	82.5	0.09	670	UWD1E331MCL1GS
	470	10×10	0.16	117.5	0.09	670	UWD1E471MCL1GS
35 (1V)	4.7	4×5.8	0.12	3	1.80	80	UWD1V47MCL1GS
	10	5×5.8	0.12	3.5	0.76	150	UWD1V100MCL1GS
	15	5×5.8	0.12	5.25	0.76	150	UWD1V150MCL1GS
	22	5×5.8	0.12	7.7	0.76	150	UWD1V220MCL1GS
	27	6.3×5.8	0.12	9.45	0.44	230	UWD1V270MCL1GS
	33	6.3×5.8	0.12	11.55	0.44	230	UWD1V330MCL1GS
	47	6.3×5.8	0.12	16.45	0.44	230	UWD1V470MCL1GS
	56	6.3×7.7	0.12	19.6	0.34	280	UWD1V560MCL1GS
	68	6.3×7.7	0.12	23.8	0.34	280	UWD1V680MCL1GS
	100	8×10	0.14	35	0.17	450	UWD1V101MCL1GS
	150	8×10	0.14	52.5	0.17	450	UWD1V151MCL1GS
	220	10×10	0.14	77	0.09	670	UWD1V221MCL1GS
	330	10×10	0.14	115.5	0.09	670	UWD1V331MCL1GS
50 (1H)	1	4×5.8	0.12	3	5.00	30	UWD1H010MCL1GS
	2.2	4×5.8	0.12	3	5.00	30	UWD1H2R2MCL1GS
	3.3	4×5.8	0.12	3	5.00	30	UWD1H3R3MCL1GS
	4.7	5×5.8	0.12	3	1.52	85	UWD1H47MCL1GS
	10	6.3×5.8	0.12	5	0.88	165	UWD1H100MCL1GS
	15	6.3×5.8	0.12	7.5	0.88	165	UWD1H150MCL1GS
	22	6.3×5.8	0.12	11	0.88	165	UWD1H220MCL1GS
	27	6.3×7.7	0.12	13.5	0.68	185	UWD1H270MCL1GS
	33	6.3×7.7	0.12	16.5	0.68	185	UWD1H330MCL1GS
	47	6.3×7.7	0.12	23.5	0.68	185	UWD1H470MCL1GS
	56	8×10	0.14	28	0.34	300	UWD1H560MCL1GS
	68	8×10	0.14	34	0.34	300	UWD1H680MCL1GS
	100	8×10	0.14	50	0.34	300	UWD1H101MCL1GS
150	10×10	0.14	75	0.18	670	UWD1H151MCL1GS	
220	10×10	0.14	110	0.18	670	UWD1H221MCL1GS	

• For taping specifications, recommended land size/soldering by reflow and minimum order quantity, please refer to the Guidelines for Aluminum Electrolytic Capacitors.

ALUMINUM ELECTROLYTIC CAPACITORS

UUB

Chip Type, High Reliability



- Chip type, high temperature range, for +125°C use.
- Applicable to automatic mounting machine fed with carrier tape.
- Compliant to the RoHS directive (2011/65/EU,(EU)2015/863).
- AEC-Q200 compliant. Please contact us for details.

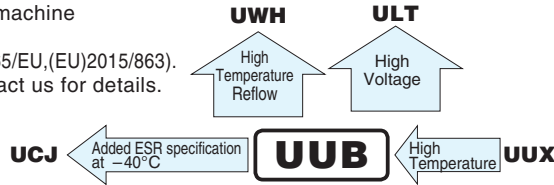

Specifications

Item	Performance Characteristics										
Category Temperature Range	-40 to +125°C										
Rated Voltage Range	10 to 400V										
Rated Capacitance Range	1 to 330μF										
Capacitance Tolerance	±20% at 120Hz, 20°C										
Leakage Current ※	Rated voltage (V)	10 to 50									
	Leakage Current	After 1 minute's application of rated voltage at 20°C, leakage current is not more than 0.03CV (μA). I = 0.04CV+100 (μA) max.(1 minute's at 20°C)									
Tangent of loss angle (tan δ)	Measurement frequency : 120Hz at 20°C										
	Rated voltage (V)	10	16	25	35	50	160	200	250	400	
Stability at Low Temperature	Measurement frequency : 120Hz										
	Rated voltage (V)	10	16	25	35	50	160	200	250	400	
Endurance	Impedance ratio ZT / Z20 (max.)	Z(-40°C) / Z(+20°C)	12	8	6	4	4	8	8	8	12
	The specifications listed at right shall be met when the capacitors are restored to 20°C after the rated voltage is applied for 2000 hours (1000 hours for φ8 × 6.2) at 125°C.		Capacitance change	Within ±30% of the initial capacitance value							
Shelf Life	After storing the capacitors under no load at 125°C for 1000 hours and then performing voltage treatment based on JIS C 5101-4 clause 4.1 at 20°C, they shall meet the specified values for the endurance characteristics listed above.		tan δ	300% or less than the initial specified value							
	The capacitors are kept on a hot plate for 30 seconds, which is maintained at 250°C. The capacitors shall meet the characteristic requirements listed at right when they are removed from the plate and restored to 20°C.		Leakage current	Less than or equal to the initial specified value							
Resistance to soldering heat	The capacitors are kept on a hot plate for 30 seconds, which is maintained at 250°C. The capacitors shall meet the characteristic requirements listed at right when they are removed from the plate and restored to 20°C.		Capacitance change	Within ±10% of the initial capacitance value							
	Black print on the case top.		tan δ	Less than or equal to the initial specified value							
Marking	Black print on the case top.		Leakage current	Less than or equal to the initial specified value							

※ I : Leakage Current (μA), C : Rated Capacitance (μF), V : Rated Voltage (V)

Chip Type

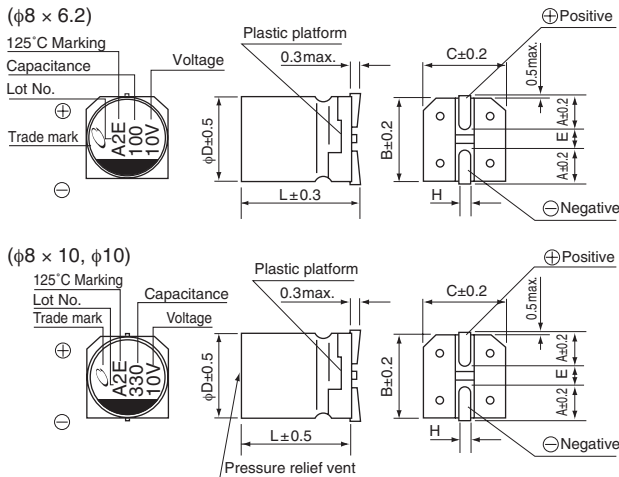

Type numbering system (Example : 10V 100μF)

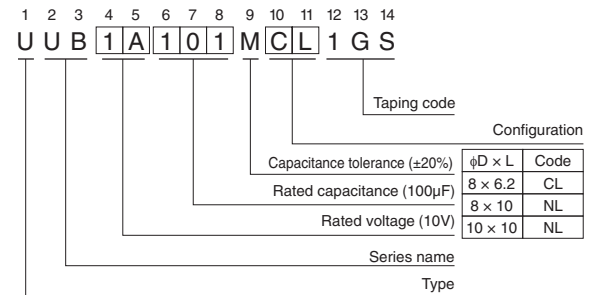

φD × L	8 × 6.2	8 × 10	10 × 10
A	3.3	2.9	3.2
B	8.3	8.3	10.3
C	8.3	8.3	10.3
E	2.3	3.1	4.5
L	6.2	10	10
H	0.5 to 0.8	0.8 to 1.1	0.8 to 1.1

Frequency coefficient of rated ripple current

Frequency	50 Hz	120 Hz	300 Hz	1 kHz	10 kHz or more
Coefficient	0.70	1.00	1.17	1.36	1.50

● Dimension table in next page.

UUB

■ Dimensions

Rated Voltage (V) (code)	Rated Capacitance (μ F)	Case Size ϕ D \times L (mm)	$\tan \delta$	Leakage Current (μ A) (at 20°C after 1 minute)	Rated Ripple (mArms) (125°C/120Hz)	Part Number
10 (1A)	100	8 \times 6.2	0.32	30	58	UUB1A101MCL1GS
	220	8 \times 10	0.32	66	90	UUB1A221MNL1GS
	330	10 \times 10	0.32	99	112	UUB1A331MNL1GS
16 (1C)	100	8 \times 10	0.24	48	66	UUB1C101MNL1GS
	220	10 \times 10	0.24	105.6	102	UUB1C221MNL1GS
25 (1E)	47	8 \times 6.2	0.21	35.25	48	UUB1E470MCL1GS
	100	8 \times 10	0.21	75	74	UUB1E101MNL1GS
	220	10 \times 10	0.21	165	116	UUB1E221MNL1GS
35 (1V)	33	8 \times 6.2	0.18	34.65	44	UUB1V330MCL1GS
	47	8 \times 10	0.18	49.35	52	UUB1V470MNL1GS
	100	10 \times 10	0.18	105	80	UUB1V101MNL1GS
50 (1H)	10	8 \times 6.2	0.18	15	24	UUB1H100MCL1GS
	22	8 \times 6.2	0.18	33	38	UUB1H220MCL1GS
	33	8 \times 10	0.18	49.5	46	UUB1H330MNL1GS
	47	10 \times 10	0.18	70.5	58	UUB1H470MNL1GS
160 (2C)	6.8	8 \times 10	0.30	143.52	42	UUB2C6R8MNL1GS
	10	10 \times 10	0.30	164	59	UUB2C100MNL1GS
200 (2D)	4.7	8 \times 10	0.30	137.6	36	UUB2D4R7MNL1GS
	6.8	10 \times 10	0.30	154.4	59	UUB2D6R8MNL1GS
	10	10 \times 10	0.30	180	59	UUB2D100MNL1GS
250 (2E)	3.3	8 \times 10	0.30	133	28	UUB2E3R3MNL1GS
	4.7	10 \times 10	0.30	147	59	UUB2E4R7MNL1GS
400 (2G)	1	8 \times 10	0.30	116	26	UUB2G010MNL1GS
	1.8	8 \times 10	0.30	128.8	27	UUB2G1R8MNL1GS
	2.2	10 \times 10	0.30	135.2	36	UUB2G2R2MNL1GS
	3.3	10 \times 10	0.30	152.8	38	UUB2G3R3MNL1GS

- For taping specifications, recommended land size/soldering by reflow and minimum order quantity, please refer to the Guidelines for Aluminum Electrolytic Capacitors.

UWH

Chip Type, High Reliability
High Temperature (260°C) Reflow



UWH

High Temperature Reflow
UUB

- Corresponding with 260°C peak reflow soldering
Recommended reflow condition : 260°C peak 5 sec. 230°C over 60 sec. 2 times (φ8 × 6.2, φ10 × 10 : 1 time)
- Chip type high temperature range, for +125°C use.
- Applicable to automatic mounting machine fed with carrier tape.
- Compliant to the RoHS directive (2011/65/EU,(EU)2015/863).
- AEC-Q200 compliant. Please contact us for details.

Specifications

Item	Performance Characteristics					
Category Temperature Range	-40 to +125°C					
Rated Voltage Range	10 to 50V					
Rated Capacitance Range	10 to 330μF					
Capacitance Tolerance	±20% at 120Hz, 20°C					
Leakage Current ※	After 1 minute's application of rated voltage at 20°C, leakage current is not more than 0.03CV or 4(μA) , whichever is greater.					
Tangent of loss angle (tan δ)	Measurement frequency : 120Hz at 20°C					
	Rated voltage (V)	10	16	25	35	50
	tan δ (max.)	0.32	0.24	0.21	0.18	0.18
Stability at Low Temperature	Measurement frequency : 120Hz					
	Rated voltage (V)	10	16	25	35	50
	Impedance ratio ZT / Z20 (max.)	Z(-40°C) / Z(+20°C)	12	8	6	4
Endurance	The specifications listed at right shall be met when the capacitors are restored to 20°C after the rated voltage is applied for 1000 hours at 125°C.		Capacitance change		Within ±30% of the initial capacitance value	
			tan δ		300% or less than the initial specified value	
			Leakage current		Less than or equal to the initial specified value	
Shelf Life	After storing the capacitors under no load at 125°C for 1000 hours and then performing voltage treatment based on JIS C 5101-4 clause 4.1 at 20°C, they shall meet the specified values for the endurance characteristics listed above.					
Resistance to soldering heat	The capacitors are kept on a hot plate for 30 seconds, which is maintained at 250°C. The capacitors shall meet the characteristic requirements listed at right when they are removed from the plate and restored to 20°C.		Capacitance change		Within ±10% of the initial capacitance value	
			tan δ		Less than or equal to the initial specified value	
			Leakage current		Less than or equal to the initial specified value	
Marking	Black print on the case top.					

※ I : Leakage Current (μA), C : Rated Capacitance (μF), V : Rated Voltage (V)

Chip Type

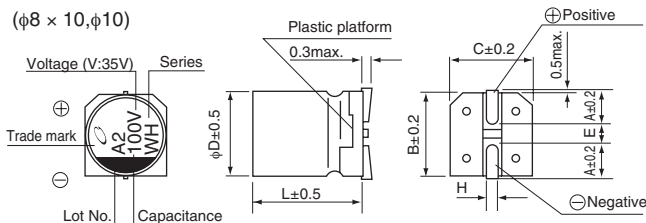
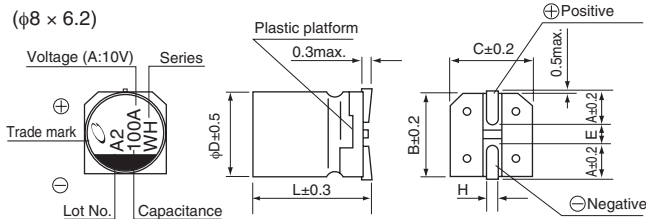

Type numbering system (Example : 10V 100μF)

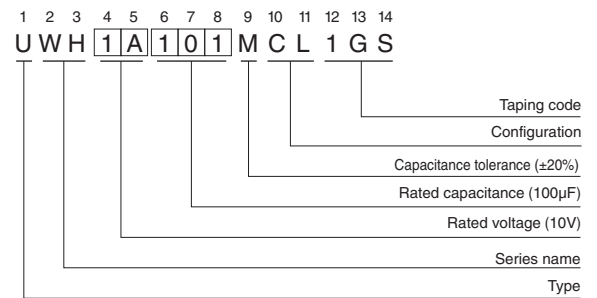

	(mm)		
φD×L	8×6.2	8×10	10×10
A	3.3	2.9	3.2
B	8.3	8.3	10.3
C	8.3	8.3	10.3
E	2.3	3.1	4.5
L	6.2	10	10
H	0.5 to 0.8	0.8 to 1.1	0.8 to 1.1

Voltage

V	10	16	25	35	50
Code	A	C	E	V	H

Frequency coefficient of rated ripple current

Frequency	50 Hz	120 Hz	300 Hz	1 kHz	10 kHz or more
Coefficient	0.70	1.00	1.17	1.36	1.50

● Dimension table in next page.

UWH

■ Dimensions

Rated Voltage (V) (code)	Rated Capacitance (μ F)	Case Size ϕ D \times L (mm)	tan δ	Leakage Current (μ A) (at 20°C after 1 minute)	Rated Ripple (mArms) (125°C/120Hz)	Part Number
10 (1A)	100	8 \times 6.2	0.32	30	58	UWH1A101MCL1GS
	220	8 \times 10	0.32	66	90	UWH1A221MCL1GS
	330	10 \times 10	0.32	99	112	UWH1A331MCL1GS
16 (1C)	100	8 \times 10	0.24	48	66	UWH1C101MCL1GS
	220	10 \times 10	0.24	105.6	102	UWH1C221MCL1GS
25 (1E)	47	8 \times 6.2	0.21	35.25	48	UWH1E470MCL1GS
	100	8 \times 10	0.21	75	74	UWH1E101MCL1GS
	220	10 \times 10	0.21	165	116	UWH1E221MCL1GS
35 (1V)	33	8 \times 6.2	0.18	34.65	44	UWH1V330MCL1GS
	47	8 \times 10	0.18	49.35	52	UWH1V470MCL1GS
	100	10 \times 10	0.18	105	80	UWH1V101MCL1GS
50 (1H)	10	8 \times 6.2	0.18	15	24	UWH1H100MCL1GS
	22	8 \times 6.2	0.18	33	38	UWH1H220MCL1GS
	33	8 \times 10	0.18	49.5	46	UWH1H330MCL1GS
	47	10 \times 10	0.18	70.5	58	UWH1H470MCL1GS

- For taping specifications, recommended land size/soldering by reflow and minimum order quantity, please refer to the Guidelines for Aluminum Electrolytic Capacitors.

ALUMINUM ELECTROLYTIC CAPACITORS

ULT Chip Type, High Voltage.
High Temperature Range.



- Chip type, high voltage and high temperature range.
- Load life of 2000 hours at +125°C.
- Applicable to automatic mounting machine using carrier tape.
- Compliant to the RoHS directive (2011/65/EU,(EU)2015/863).
- AEC-Q200 compliant. Please contact us for details.

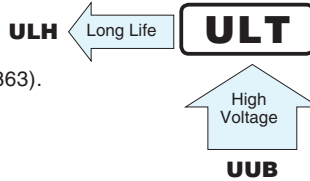

Specifications

Item	Performance Characteristics	
Category Temperature Range	-40 to +125°C	
Rated Voltage Range	160 to 500V	
Rated Capacitance Range	1.8 to 33μF	
Capacitance Tolerance	±20% at 120Hz, 20°C	
Leakage Current ※	Rated voltage (V)	160-450
	-	0.04CV+100(μA)max.(1 minute's at 20°C)
Tangent of loss angle (tan δ)	Measurement frequency : 120Hz at 20°C	
	Rated voltage (V)	160 200 250 400 450 500
Stability at Low Temperature	Measurement frequency : 120Hz	
	Impedance ratio ZT / Z20 (max.)	Z(-40°C) / Z(+20°C)
Endurance	The specifications listed at right shall be met when the capacitors are restored to 20°C after the rated voltage is applied for 2000 hours at 125°C.	
	Capacitance change	tan δ
Shelf Life	After storing the capacitors under no load at 125°C for 1000 hours and then performing voltage treatment based on JIS C 5101-4 clause 4.1 at 20°C, they shall meet the specified values for the endurance characteristics listed above.	
	Capacitance change	tan δ
Resistance to soldering heat	The capacitors are kept on a hot plate for 30 seconds, which is maintained at 250°C and then performing voltage treatment based on JIS C 5101-4 clause 4.1 at 20°C, they shall meet the characteristic requirements listed at right when they are removed from the plate.	
	Capacitance change	tan δ
Marking	Black print on the case top.	

※ I : Leakage Current (μA), C : Rated Capacitance (μF), V : Rated Voltage (V)

Chip Type

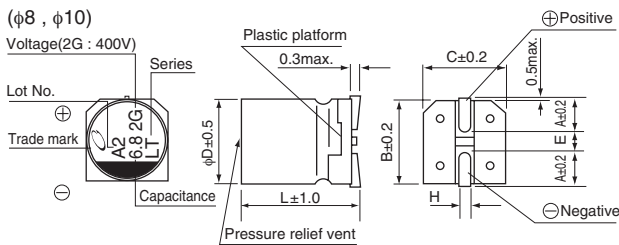

φD×L	8×10	10×10	10×13.5
A	2.9	3.2	3.2
B	8.3	10.3	10.3
C	8.3	10.3	10.3
E	3.1	4.5	4.5
L	10	10	13.5
H	0.8 to 1.1	0.8 to 1.1	0.8 to 1.1

Voltage	V	160	200	250	400	450	500
Code	2C	2D	2E	2G	2W	2H	

Type numbering system (Example : 400V 6.8μF)

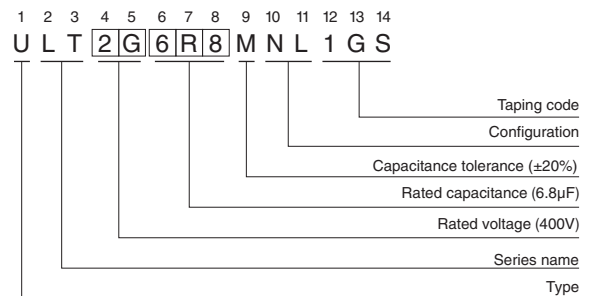

Frequency coefficient of rated ripple current

Frequency	50 Hz	120 Hz	300 Hz	1 kHz	10 kHz or more
Coefficient	0.70	1.00	1.17	1.36	1.50

● Dimension table in next page.

ULT

■ Dimensions

Rated Voltage (V) (code)	Rated Capacitance (μ F)	Case Size ϕ D \times L (mm)	tan δ	Leakage Current (μ A) (at 20°C after 1 minute)	Rated Ripple (mArms) (125°C/120Hz)	Part Number
160 (2C)	15	8 \times 10	0.20	196	45	ULT2C150MNL1GS
	22	10 \times 10	0.20	240.8	60	ULT2C220MNL1GS
	33	10 \times 13.5	0.20	311.2	65	ULT2C330MNL1GS
200 (2D)	12	8 \times 10	0.20	196	45	ULT2D120MNL1GS
	18	10 \times 10	0.20	244	60	ULT2D180MNL1GS
	27	10 \times 13.5	0.20	316	65	ULT2D270MNL1GS
250 (2E)	8.2	8 \times 10	0.25	182	30	ULT2E8R2MNL1GS
	15	10 \times 10	0.25	250	45	ULT2E150MNL1GS
	18	10 \times 13.5	0.25	280	50	ULT2E180MNL1GS
400 (2G)	3.9	8 \times 10	0.25	162.4	30	ULT2G3R9MNL1GS
	6.8	10 \times 10	0.25	208.8	45	ULT2G6R8MNL1GS
	10	10 \times 13.5	0.25	260	50	ULT2G100MNL1GS
450 (2W)	3.3	8 \times 10	0.30	159.4	20	ULT2W3R3MNL1GS
	5.6	10 \times 10	0.30	200.8	35	ULT2W5R6MNL1GS
	7.5	10 \times 13.5	0.30	235	40	ULT2W7R5MNL1GS
500 (2H)	1.8	8 \times 10	0.30	236	20	ULT2H1R8MNL1GS
	3.3	10 \times 10	0.30	266	35	ULT2H3R3MNL1GS
	4.7	10 \times 13.5	0.30	294	40	ULT2H4R7MNL1GS

- For taping specifications, recommended land size/soldering by reflow and minimum order quantity, please refer to the Guidelines for Aluminum Electrolytic Capacitors.

ALUMINUM ELECTROLYTIC CAPACITORS

ULH

Chip Type, High Voltage.
High Reliability.



- Chip type, High voltage and High Reliability.
- Load life of 4000 hours at +125°C.
- Applicable to automatic mounting machine using carrier tape.
- Compliant to the RoHS directive (2011/65/EU,(EU)2015/863).
- AEC-Q200 compliant. Please contact us for details.



Specifications

Item	Performance Characteristics						
Category Temperature Range	-40 to +125°C						
Rated Voltage Range	160 to 450V						
Rated Capacitance Range	2.2 to 27μF						
Capacitance Tolerance	±20% at 120Hz, 20°C						
Leakage Current ※	After 1 minute's application of rated voltage at 20°C, leakage current is not more than 0.04CV+100 (μA).						
Tangent of loss angle (tan δ)	Measurement frequency : 120Hz at 20°C						
	Rated voltage (V)	160	200	250	400	450	
	tan δ (max.)	0.20	0.20	0.25	0.25	0.30	
Stability at Low Temperature	Measurement frequency : 120Hz						
	Rated voltage (V)	160	200	250	400	450	
	Impedance ratio Z(-40°C) / Z(+20°C)	6	6	10	10	15	
Endurance	The specifications listed at right shall be met when the capacitors are restored to 20°C after the rated voltage is applied for 4000 hours at 125°C.					Capacitance change	Within ±30% of the initial capacitance value
						tan δ	300% or less than the initial specified value
Shelf Life	After storing the capacitors under no load at 125°C for 1000 hours and then performing voltage treatment based on JIS C 5101-4 clause 4.1 at 20°C, they shall meet the specified values for the endurance characteristics listed above.					Leakage current	Less than or equal to the initial specified value
Resistance to soldering heat	The capacitors are kept on a hot plate for 30 seconds, which is maintained at 250°C and then performing voltage treatment based on JIS C 5101-4 clause 4.1 at 20°C, they shall meet the characteristic requirements listed at right when they are removed from the plate.					Capacitance change	Within ±10% of the initial capacitance value
						tan δ	Less than or equal to the initial specified value
Marking						Leakage current	Less than or equal to the initial specified value
	Black print on the case top.						

※ I : Leakage Current (μA), C : Rated Capacitance (μF), V : Rated Voltage (V)

Chip Type

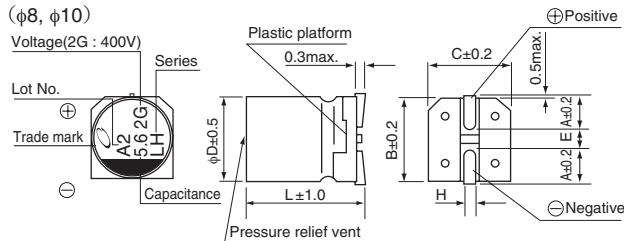

φD×L	8×10	10×10	10×13.5
A	2.9	3.2	3.2
B	8.3	10.3	10.3
C	8.3	10.3	10.3
E	3.1	4.5	4.5
L	10	10	13.5
H	0.8 to 1.1	0.8 to 1.1	0.8 to 1.1

Voltage	160	200	250	400	450
Code	2C	2D	2E	2G	2W

Type numbering system (Example : 400V 5.6μF)

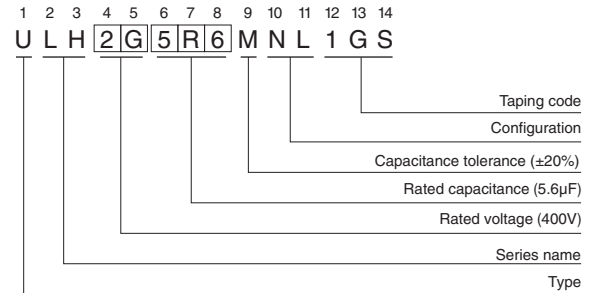

Frequency coefficient of rated ripple current

Frequency	50 Hz	120 Hz	300 Hz	1 kHz	10 kHz or more
Coefficient	0.70	1.00	1.17	1.36	1.50

● Dimension table in next page.

ULH

■ Dimensions

Rated Voltage (V) (code)	Rated Capacitance (μ F)	Case Size ϕ D \times L (mm)	tan δ	Leakage Current (μ A) (at 20°C after 1 minute)	Rated Ripple (mArms) (125°C/120Hz)	Part Number
160 (2C)	12	8 \times 10	0.20	176.8	45	ULH2C120MNL1GS
	18	10 \times 10	0.20	215.2	60	ULH2C180MNL1GS
	27	10 \times 13.5	0.20	272.8	65	ULH2C270MNL1GS
200 (2D)	10	8 \times 10	0.20	180	45	ULH2D100MNL1GS
	15	10 \times 10	0.20	220	60	ULH2D150MNL1GS
	22	10 \times 13.5	0.20	276	65	ULH2D220MNL1GS
250 (2E)	7.5	8 \times 10	0.25	175	30	ULH2E7R5MNL1GS
	12	10 \times 10	0.25	220	45	ULH2E120MNL1GS
	15	10 \times 13.5	0.25	250	50	ULH2E150MNL1GS
400 (2G)	3.3	8 \times 10	0.25	152.8	30	ULH2G3R3MNL1GS
	5.6	10 \times 10	0.25	189.6	45	ULH2G5R6MNL1GS
	7.5	10 \times 13.5	0.25	220	50	ULH2G7R5MNL1GS
450 (2W)	2.2	8 \times 10	0.30	139.6	20	ULH2W2R2MNL1GS
	3.9	10 \times 10	0.30	170.2	35	ULH2W3R9MNL1GS
	5.6	10 \times 13.5	0.30	200.8	40	ULH2W5R6MNL1GS

- For taping specifications, recommended land size/soldering by reflow and minimum order quantity, please refer to the Guidelines for Aluminum Electrolytic Capacitors.

ALUMINUM ELECTROLYTIC CAPACITORS



Chip Type, High Reliability.
Low temperature ESR specification.



For SMD Long Life Anti-Solvent Feature



- Chip type, high temperature range, for +125°C use.
 - Added ESR specification after the test at -40°C (φ6.3 sizes provide only for the first stage.)
 - Applicable to automatic mounting machine fed with carrier tape.
 - Compliant to the RoHS directive (2011/65/EU,(EU)2015/863).
 - AEC-Q200 compliant.
- Please contact us for details.



Specifications

Item	Performance Characteristics												
Category Temperature Range	-40 to +125°C												
Rated Voltage Range	10 to 50V												
Rated Capacitance Range	10 to 470μF												
Capacitance Tolerance	±20% at 120Hz, 20°C												
Leakage Current ※	After 1 minute's application of rated voltage at 20°C, leakage current is not more than 0.03CV or 4(μA), whichever is greater.												
Tangent of loss angle (tan δ)	Measurement frequency : 120Hz at 20°C												
	<table border="1"> <tr> <td>Rated voltage (V)</td> <td>10</td> <td>16</td> <td>25</td> <td>35</td> <td>50</td> </tr> <tr> <td>tan δ (max.)</td> <td>0.32</td> <td>0.24</td> <td>0.21</td> <td>0.18</td> <td>0.18</td> </tr> </table>	Rated voltage (V)	10	16	25	35	50	tan δ (max.)	0.32	0.24	0.21	0.18	0.18
Rated voltage (V)	10	16	25	35	50								
tan δ (max.)	0.32	0.24	0.21	0.18	0.18								
Stability at Low Temperature	Measurement frequency : 120Hz												
	<table border="1"> <tr> <td>Rated voltage (V)</td> <td>10</td> <td>16</td> <td>25</td> <td>35</td> <td>50</td> </tr> <tr> <td>Impedance ratio ZT / Z20 (max.)</td> <td>Z(-40°C) / Z(+20°C)</td> <td>12</td> <td>8</td> <td>6</td> <td>4</td> <td>4</td> </tr> </table>	Rated voltage (V)	10	16	25	35	50	Impedance ratio ZT / Z20 (max.)	Z(-40°C) / Z(+20°C)	12	8	6	4
Rated voltage (V)	10	16	25	35	50								
Impedance ratio ZT / Z20 (max.)	Z(-40°C) / Z(+20°C)	12	8	6	4	4							
Endurance	<p>The specifications listed at right shall be met when the capacitors are restored to 20°C after the rated voltage is applied for 2000 hours at 125°C.</p> <table border="1"> <tr> <td>Capacitance change</td> <td>Within ±30% of the initial capacitance value</td> </tr> <tr> <td>tan δ</td> <td>300% or less than the initial specified value</td> </tr> <tr> <td>Leakage current</td> <td>Less than or equal to the initial specified value</td> </tr> </table>	Capacitance change	Within ±30% of the initial capacitance value	tan δ	300% or less than the initial specified value	Leakage current	Less than or equal to the initial specified value						
Capacitance change	Within ±30% of the initial capacitance value												
tan δ	300% or less than the initial specified value												
Leakage current	Less than or equal to the initial specified value												
Shelf Life	After storing the capacitors under no load at 125°C for 1000 hours and then performing voltage treatment based on JIS C 5101-4 clause 4.1 at 20°C, they shall meet the specified values for the endurance characteristics listed above.												
Resistance to soldering heat	<p>The capacitors are kept on a hot plate for 30 seconds, which is maintained at 250°C. The capacitors shall meet the characteristic requirements listed at right when they are removed from the plate and restored to 20°C.</p> <table border="1"> <tr> <td>Capacitance change</td> <td>Within ±10% of the initial capacitance value</td> </tr> <tr> <td>tan δ</td> <td>Less than or equal to the initial specified value</td> </tr> <tr> <td>Leakage current</td> <td>Less than or equal to the initial specified value</td> </tr> </table>	Capacitance change	Within ±10% of the initial capacitance value	tan δ	Less than or equal to the initial specified value	Leakage current	Less than or equal to the initial specified value						
Capacitance change	Within ±10% of the initial capacitance value												
tan δ	Less than or equal to the initial specified value												
Leakage current	Less than or equal to the initial specified value												
Marking	Black print on the case top.												

※ I : Leakage Current (μA), C : Rated Capacitance (μF), V : Rated Voltage (V)

Chip Type

(φ6.3)

Voltage (V : 16V)

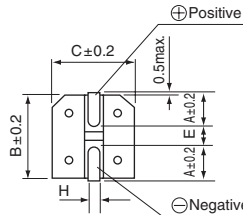
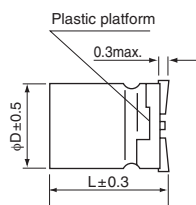
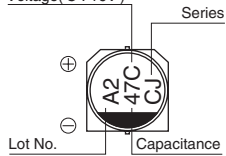

(φ8, φ10)

Voltage (V : 35V)

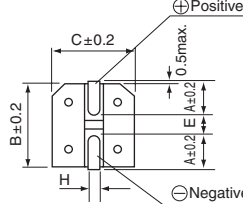
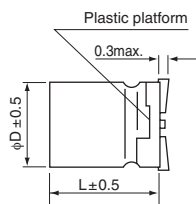
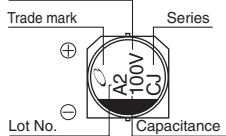

Type numbering system (Example : 10V 100μF)

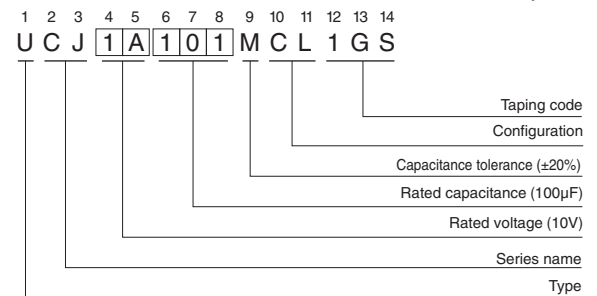

φD x L	6.3 x 8.7	8 x 10	10 x 10
A	2.4	2.9	3.2
B	6.6	8.3	10.3
C	6.6	8.3	10.3
E	2.2	3.1	4.5
L	8.7	10	10
H	0.5 to 0.8	0.8 to 1.1	0.8 to 1.1

Voltage

V	10	16	25	35	50
Code	A	C	E	V	H

Frequency coefficient of rated ripple current

Frequency	50 Hz	120 Hz	300 Hz	1 kHz	10 kHz or more
Coefficient	0.35	0.50	0.64	0.83	1.00

● Dimension table in next page.

UCJ

■ Dimensions

Rated Voltage (V) (code)	Rated Capacitance (μ F)	Case Size ϕ D \times L (mm)	tan δ	Leakage Current (μ A) (at 20°C after 1 minute)	ESR (Ω) max. (-40°C/100kHz)		Rated Ripple (mArms) (125°C/100kHz)	Part Number
					Initial	after endurance test		
10 (1A)	100	6.3 \times 8.7	0.32	30	14	—	95	UCJ1A101MCL1GS
	220	8 \times 10	0.32	66	2.0	6.0	250	UCJ1A221MCL1GS
	330	10 \times 10	0.32	99	1.5	4.5	400	UCJ1A331MCL1GS
	470	10 \times 10	0.32	141	1.5	4.5	400	UCJ1A471MCL1GS
16 (1C)	47	6.3 \times 8.7	0.24	22.56	14	—	95	UCJ1C470MCL1GS
	100	8 \times 10	0.24	48	2.0	6.0	250	UCJ1C101MCL1GS
	220	10 \times 10	0.24	105.6	1.5	4.5	400	UCJ1C221MCL1GS
	330	10 \times 10	0.24	158.4	1.5	4.5	400	UCJ1C331MCL1GS
25 (1E)	22	6.3 \times 8.7	0.21	16.5	14	—	95	UCJ1E220MCL1GS
	33	6.3 \times 8.7	0.21	24.75	14	—	95	UCJ1E330MCL1GS
	47	6.3 \times 8.7	0.21	35.25	14	—	95	UCJ1E470MCL1GS
	100	8 \times 10	0.21	75	2.0	6.0	250	UCJ1E101MCL1GS
	220	10 \times 10	0.21	165	1.5	4.5	400	UCJ1E221MCL1GS
	330	10 \times 10	0.21	247.5	1.5	4.5	400	UCJ1E331MCL1GS
35 (1V)	10	6.3 \times 8.7	0.18	10.5	14	—	95	UCJ1V100MCL1GS
	22	6.3 \times 8.7	0.18	23.1	14	—	95	UCJ1V220MCL1GS
	33	6.3 \times 8.7	0.18	34.65	14	—	95	UCJ1V330MCL1GS
	47	6.3 \times 8.7	0.18	49.35	14	—	95	UCJ1V470MCL1GS
	100	10 \times 10	0.18	105	1.5	4.5	400	UCJ1V101MCL1GS
	220	10 \times 10	0.18	231	1.5	4.5	400	UCJ1V221MCL1GS
50 (1H)	10	6.3 \times 8.7	0.18	15	14	—	95	UCJ1H100MCL1GS
	22	6.3 \times 8.7	0.18	33	14	—	95	UCJ1H220MCL1GS
	33	8 \times 10	0.18	49.5	2.0	6.0	200	UCJ1H330MCL1GS
	47	10 \times 10	0.18	70.5	1.5	4.5	330	UCJ1H470MCL1GS
	100	10 \times 10	0.18	150	1.5	4.5	330	UCJ1H101MCL1GS

• For taping specifications, recommended land size/soldering by reflow and minimum order quantity, please refer to the Guidelines for Aluminum Electrolytic Capacitors.

ALUMINUM ELECTROLYTIC CAPACITORS

UCZ

Chip Type, High Reliability.
Low temperature ESR specification.



- Chip type, high temperature range, for +125°C use.
- Added ESR specification after the test at -40°C.
- Applicable to automatic mounting machine fed with carrier tape.
- Compliant to the RoHS directive (2011/65/EU, (EU)2015/863).
- AEC-Q200 compliant. Please contact us for details.

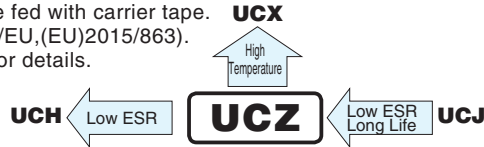

Specifications

Item	Performance Characteristics					
Category Temperature Range	-40 to +125°C					
Rated Voltage Range	10 to 100V					
Rated Capacitance Range	10 to 3300µF					
Capacitance Tolerance	±20% at 120Hz, 20°C					
Leakage Current ※	After 2 minutes' application of rated voltage at 20°C, leakage current is not more than 0.01CV or 3µA, whichever is greater.					
Tangent of loss angle (tan δ)	Rated voltage (V)	10 16 25 35 50 63 80 100				
	tan δ (max.)	0.30 0.23 0.18 0.16 0.16 0.12 0.12 0.10				
		Measurement frequency : 120Hz at 20°C				
		For capacitance of more than 1000µF, add 0.02 for every increase of 1000µF. (φ12.5 to φ18)				
Stability at Low Temperature	Rated voltage (V)	10 16 25 35 50 63 80 100				
	Impedance ratio (max.)	Z(-40°C) / Z(+20°C) 12 8 6 4 4 3 3 3				
		Measurement frequency : 120Hz				
Endurance	After continuous application of rated voltage at 125°C and then restoring down to 20°C, the readings of measurements shall meet below.					
	Case size	φ6.3 × 5.8L	φ6.3 × 7.7L	φ8 to φ12.5	φ16.18 × 16.5L	φ16.18 × 21.5L
	Endurance time	1000hrs.	2000hrs.	3000hrs.	3500hrs.	4000hrs.
	Capacitance change	Within ±30% of the initial capacitance value				
tan δ	300% or less than the initial specified value					
Leakage current	Less than or equal to the initial specified value					
Shelf Life	After storing the capacitors under no load at 125°C for 1000 hours and then performing voltage treatment based on JIS C 5101-4 clause 4.1 at 20°C, they shall meet the specified values for the endurance characteristics listed above.					
Resistance to soldering heat	The capacitors are kept on a hot plate for 30 seconds, which is maintained at 250°C. The capacitors shall meet the characteristic requirements listed at right when they are removed from the plate and restored to 20°C.					
	Capacitance change	Within ±10% of the initial capacitance value				
tan δ	Less than or equal to the initial specified value					
Leakage current	Less than or equal to the initial specified value					
Marking	Black print on the case top.					

Chip Type

(φ 6.3) 【Standard】 ※ φ6.3 × 5.8L : The vibration structure-resistant product can't support.
φ6.3 × 7.7L : The vibration structure-resistant product is available.

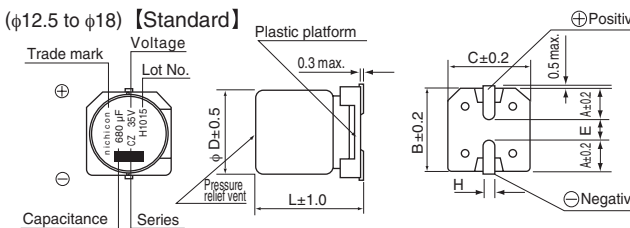
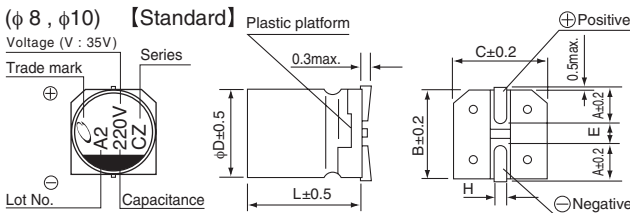
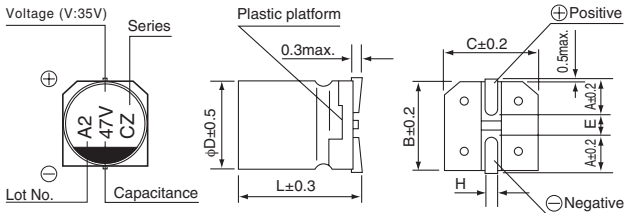

Standard	(mm)						Vibration Resistance (mm)							
φDxL	6.3X5.8	6.3X7.7	8X10	10X10	12.5X13.5	16X16.5	21.5	18X16.5	21.5	8X10	10X10	φ12.5	φ16	φ18
A	2.4	2.4	2.9	3.2	5.15	5.65	6.65			2.9	3.2	4.8	5.4	6.4
B	6.6	6.6	8.3	10.3	13.6	17.1	19.1			8.3	10.3	13.6	17.1	19.1
C	6.6	6.6	8.3	10.3	13.6	17.1	19.1			8.3	10.3	13.6	17.1	19.1
E	2.2	2.2	3.1	4.5	(3.3)	(5.8)	(5.8)			3.1	4.5	(4.0)	(6.3)	(6.3)
L	5.8	7.7	10	10	13.5	16.5, 21.5	16.5, 21.5			10	10	13.5	16.5, 21.5	16.5, 21.5
H	0.5 to 0.8	0.5 to 0.8	0.8 to 1.1	0.8 to 1.1	1.0 to 1.4	1.0 to 1.4	1.0 to 1.4			1.1 to 1.5	1.1 to 1.5	1.0 to 1.4	1.0 to 1.4	1.0 to 1.4

Please contact us for the dimensions for NQ.

● Dimension table in next page.

※ I : Leakage Current (µA), C : Rated Capacitance (µF), V : Rated Voltage (V)

Type numbering system (Example : 35V 47µF)

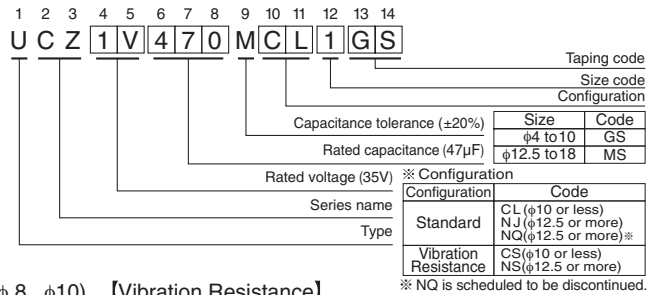

(φ 8, φ10) 【Vibration Resistance】

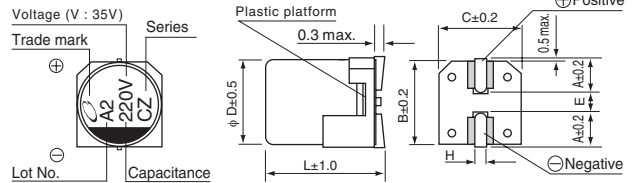

(φ12.5 to φ18) 【Vibration Resistance】

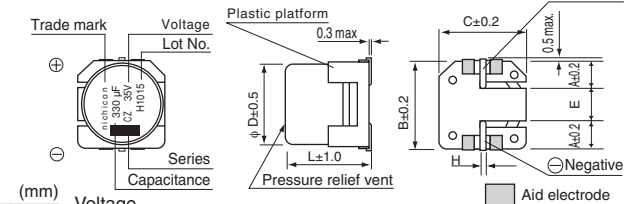

Voltage	10	16	25	35	50	63	80	100
V	10	16	25	35	50	63	80	100
Code	A	C	E	V	H	J	K	2A

● Frequency coefficient of rated ripple current

Frequency	50Hz	120Hz	300Hz	1kHz	10kHz or more
Coefficient	0.35	0.50	0.64	0.83	1.00



■ Dimensions

Rated Voltage (V) (code)	Rated Capacitance (μF)	Case Size φD×L (mm)	tan δ	Leakage Current (μA) (at 20°C after 2 minutes)	ESR (Ω) max. (20°C/−40°C/100kHz)			Rated Ripple (mArms) (125°C/100kHz)	Part Number
					Initial 20°C	Initial −40°C	after endurance test −40°C ※		
10 (1A)	220	8×10	0.30	22	0.20	3.00	4.5	270	UCZ1A221M□□1GS
	330	8×10	0.30	33	0.20	3.00	4.5	270	UCZ1A331M□□6GS
	330	10×10	0.30	33	0.15	2.00	3.5	500	UCZ1A331M□□1GS
	470	10×10	0.30	47	0.15	2.00	3.5	500	UCZ1A471M□□1GS
16 (1C)	47	6.3×5.8	0.23	7.52	1.60	24.00	—	69	UCZ1C470MCL1GS
	100	6.3×7.7	0.23	16	0.45	5.00	40	197	UCZ1C101M□□6GS
	100	8×10	0.23	16	0.20	3.00	4.5	270	UCZ1C101M□□1GS
	220	8×10	0.23	35.2	0.20	3.00	4.5	270	UCZ1C221M□□1GS
	330	10×10	0.23	52.8	0.15	2.00	3.5	500	UCZ1C331M□□1GS
	470	10×10	0.23	75.2	0.15	2.00	3.5	500	UCZ1C471M□□1GS
25 (1E)	33	6.3×5.8	0.18	8.25	1.60	24.00	—	69	UCZ1E330MCL1GS
	100	6.3×7.7	0.18	25	0.45	5.00	40	197	UCZ1E101M□□6GS
	100	8×10	0.18	25	0.20	3.00	4.5	270	UCZ1E101M□□1GS
	220	8×10	0.18	55	0.20	3.00	4.5	270	UCZ1E221M□□6GS
	220	10×10	0.18	55	0.15	2.00	3.5	500	UCZ1E221M□□1GS
	330	10×10	0.18	82.5	0.15	2.00	3.5	500	UCZ1E331M□□1GS
	820	12.5×13.5	0.18	205	0.060	0.40	3	1700	UCZ1E821M□□1MS
	1000	12.5×13.5	0.18	250	0.060	0.40	3	1700	UCZ1E102M□□1MS
	1200	16×16.5	0.18	300	0.047	0.28	1.4	1700	UCZ1E122M□□1MS
	1600	16×16.5	0.18	400	0.047	0.28	1.4	2400	UCZ1E162M□□1MS
	2200	18×16.5	0.20	550	0.045	0.23	1.3	2600	UCZ1E222M□□1MS
	2700	16×21.5	0.20	675	0.034	0.20	0.6	3000	UCZ1E272M□□1MS
3300	18×21.5	0.22	825	0.032	0.16	0.5	3250	UCZ1E332M□□1MS	
35 (1V)	10	6.3×5.8	0.16	3.5	1.60	24.00	—	69	UCZ1V100MCL1GS
	22	6.3×5.8	0.16	7.7	1.60	24.00	—	69	UCZ1V220MCL1GS
	33	6.3×7.7	0.16	11.55	0.45	5.00	40	197	UCZ1V330M□□1GS
	47	6.3×7.7	0.16	16.45	0.45	5.00	40	197	UCZ1V470M□□6GS
	47	8×10	0.16	16.45	0.20	3.00	4.5	270	UCZ1V470M□□1GS
	68	8×10	0.16	23.8	0.20	3.00	4.5	270	UCZ1V680M□□1GS
	100	8×10	0.16	35	0.20	3.00	4.5	270	UCZ1V101M□□1GS
	220	10×10	0.16	77	0.15	2.00	3.5	500	UCZ1V221M□□1GS
	470	12.5×13.5	0.16	164.5	0.060	0.40	3.0	1700	UCZ1V471M□□1MS
	560	12.5×13.5	0.16	196	0.060	0.40	3.0	1700	UCZ1V561M□□1MS
	680	12.5×13.5	0.16	238	0.060	0.40	3.0	1700	UCZ1V681M□□1MS
	820	16×16.5	0.16	287	0.047	0.28	1.4	2400	UCZ1V821M□□1MS
	1000	16×16.5	0.16	350	0.047	0.28	1.4	2400	UCZ1V102M□□1MS
	1200	18×16.5	0.16	420	0.045	0.28	1.4	2600	UCZ1V122M□□1MS
	1400	18×16.5	0.16	490	0.045	0.28	1.4	2600	UCZ1V142M□□1MS
	1600	16×21.5	0.16	560	0.034	0.20	0.6	3000	UCZ1V162M□□1MS
2200	18×21.5	0.18	770	0.032	0.16	0.5	3250	UCZ1V222M□□1MS	
50 (1H)	10	6.3×5.8	0.16	5	2.80	42.00	—	51	UCZ1H100MCL1GS
	22	6.3×7.7	0.16	11	0.50	5.00	40	197	UCZ1H220M□□1GS
	33	6.3×7.7	0.16	16.5	0.50	5.00	40	197	UCZ1H330M□□6GS
	33	8×10	0.16	16.5	0.25	3.50	6	270	UCZ1H330M□□1GS
	47	6.3×7.7	0.16	23.5	0.50	5.00	40	197	UCZ1H470M□□6GS
	47	8×10	0.16	23.5	0.25	3.50	6	270	UCZ1H470M□□1GS
	100	10×10	0.16	50	0.20	2.50	4.5	500	UCZ1H101M□□1GS
	390	12.5×13.5	0.16	195	0.10	0.44	4.0	1300	UCZ1H391M□□1MS
	470	16×16.5	0.16	235	0.080	0.34	2.6	2000	UCZ1H471M□□1MS
	560	16×16.5	0.16	280	0.080	0.34	2.6	2000	UCZ1H561M□□1MS
	680	18×16.5	0.16	340	0.078	0.32	2.6	2100	UCZ1H681M□□1MS
	820	18×16.5	0.16	410	0.078	0.32	2.6	2100	UCZ1H821M□□1MS
	1000	16×21.5	0.16	500	0.040	0.22	1.5	2800	UCZ1H102M□□1MS
	1200	18×21.5	0.16	600	0.038	0.20	1.5	2900	UCZ1H122M□□1MS

□□ : Enter the appropriate configuration code.



■ Dimensions

Rated Voltage (V) (code)	Rated Capacitance (μF)	Case Size φD×L (mm)	tan δ	Leakage Current (μA) (at 20°C after 2 minutes)	ESR (Ω) max. (20°C/−40°C/100kHz)			Rated Ripple (mArms) (125°C/100kHz)	Part Number
					Initial 20°C	Initial −40°C	after endurance test −40°C ※		
63 (1J)	10	6.3×7.7	0.12	6.3	2.00	100.00	—	60	UCZ1J100M□□1GS
	22	8×10	0.12	13.86	0.70	35.00	—	100	UCZ1J220M□□1GS
	33	8×10	0.12	20.79	0.70	35.00	—	100	UCZ1J330M□□6GS
	33	10×10	0.12	20.79	0.50	25.00	—	170	UCZ1J330M□□1GS
	47	8×10	0.12	29.61	0.70	35.00	—	100	UCZ1J470M□□6GS
	47	10×10	0.12	29.61	0.50	25.00	—	170	UCZ1J470M□□1GS
	150	12.5×13.5	0.12	94.5	0.20	1.30	14	1000	UCZ1J151M□□1MS
	180	12.5×13.5	0.12	113.4	0.20	1.30	14	1000	UCZ1J181M□□1MS
	220	12.5×13.5	0.12	138.6	0.20	1.30	14	1000	UCZ1J221M□□1MS
	390	16×16.5	0.12	245.7	0.13	0.90	4.8	1900	UCZ1J391M□□1MS
	470	18×16.5	0.12	296.1	0.11	0.82	3.9	2000	UCZ1J471M□□1MS
80 (1K)	10	8×10	0.12	8	0.75	50.00	—	70	UCZ1K100M□□1GS
	22	8×10	0.12	17.6	0.75	50.00	—	70	UCZ1K220M□□6GS
	22	10×10	0.12	17.6	0.55	35.00	—	115	UCZ1K220M□□1GS
	33	8×10	0.12	26.4	0.75	50.00	—	70	UCZ1K330M□□6GS
	33	10×10	0.12	26.4	0.55	35.00	—	115	UCZ1K330M□□1GS
	47	10×10	0.12	37.6	0.55	35.00	—	115	UCZ1K470M□□1GS
	150	12.5×13.5	0.12	120	0.28	1.90	14	700	UCZ1K151M□□1MS
	270	16×16.5	0.12	216	0.19	1.40	4.8	1000	UCZ1K271M□□1MS
	330	18×16.5	0.12	264	0.17	1.10	3.9	1100	UCZ1K331M□□1MS
	390	16×21.5	0.12	312	0.12	0.80	2.6	1600	UCZ1K391M□□1MS
	520	18×21.5	0.12	416	0.11	0.70	2.4	1700	UCZ1K521M□□1MS
100 (2A)	10	8×10	0.10	10	0.75	50.00	—	70	UCZ2A100M□□1GS
	22	8×10	0.10	22	0.75	50.00	—	70	UCZ2A220M□□6GS
	22	10×10	0.10	22	0.55	35.00	—	115	UCZ2A220M□□1GS
	33	10×10	0.10	33	0.55	35.00	—	115	UCZ2A330M□□1GS
	82	12.5×13.5	0.10	82	0.28	1.90	22	700	UCZ2A820M□□1MS
	150	16×16.5	0.10	150	0.19	1.40	4.8	1000	UCZ2A151M□□1MS
	180	18×16.5	0.10	180	0.17	1.10	3.9	1100	UCZ2A181M□□1MS
	220	16×21.5	0.10	220	0.12	0.80	2.6	1600	UCZ2A221M□□1MS
	300	18×21.5	0.10	300	0.11	0.70	2.4	1700	UCZ2A301M□□1MS

□□ : Enter the appropriate configuration code.

※ Guaranteed time of ESR after endurance test

Size	Guaranteed time
φ6.3 × 5.8L	—
φ6.3 × 7.7L, φ8 × 10L	10 to 50V 2000hrs.
φ10 × 10L	63 to 100V —
φ12.5	2000hrs.
φ16, 18 × 16.5L	2000hrs.
φ16, 18 × 21.5L	3000hrs.

- For taping specifications, recommended land size/soldering by reflow and minimum order quantity, please refer to the Guidelines for Aluminum Electrolytic Capacitors.

UYA Chip Type, Long Life Assurance



NEW

- Chip type, Extended load life of 5000hours at +125°C.
- Applicable to automatic mounting machine fed with carrier tape.
- Compliant to the RoHS directive (2011/65/EU, (EU)2015/863).
- AEC-Q200 compliant. Please contact us for details.

UYA ← Long Life Higher Capacitance → **UCZ**



Specifications

Item	Performance Characteristics				
Category Temperature Range	-40 to +125°C				
Rated Voltage Range	63 to 100V				
Rated Capacitance Range	90 to 880μF				
Capacitance Tolerance	±20% at 120Hz, 20°C				
Leakage Current ※	After 2 minutes' application of rated voltage at 20°C, leakage current is not more than 0.01CV or 3(μA), whichever is greater.				
Tangent of loss angle (tan δ)	Measurement frequency : 120Hz at 20°C				
	Rated voltage (V)	63	80	100	
	tan δ (max.)	0.12	0.12	0.1	
Stability at Low Temperature	Measurement frequency : 120Hz				
	Rated voltage (V)	63	80	100	
	Impedance ratio (max.)	Z(-40°C) / Z(+20°C)	3	3	3
Endurance	The specifications listed at right shall be met when the capacitors are restored to 20°C after the rated voltage is applied for 5000 hours at 125°C.		Capacitance change	Within ±30% of the initial capacitance value	
			tan δ	300% or less than the initial specified value	
Shelf Life	After storing the capacitors under no load at 125°C for 1000 hours and then performing voltage treatment based on JIS C 5101-4 clause 4.1 at 20°C, they shall meet the specified values for the endurance characteristics listed above.		Leakage current	Less than or equal to the initial specified value	
Resistance to soldering heat	The capacitors are kept on a hot plate for 30 seconds, which is maintained at 250°C. The capacitors shall meet the characteristic requirements listed at right when they are removed from the plate and restored to 20°C.		Capacitance change	Within ±10% of the initial capacitance value	
			tan δ	Less than or equal to the initial specified value	
Marking	Black print on the case top.		Leakage current	Less than or equal to the initial specified value	

※ I : Leakage Current (μA), C : Rated Capacitance (μF), V : Rated Voltage (V)

Chip Type

(φ12.5 to φ18)

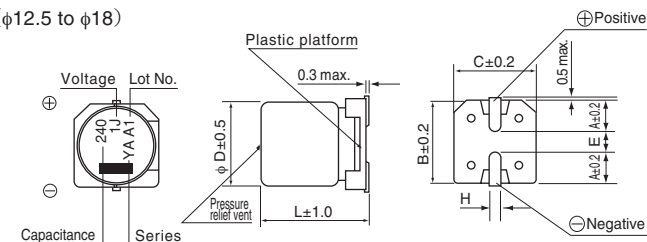

	(mm)				
φD×L	12.5×13.5	16×16.5	16×21.5	18×16.5	18×21.5
A	5.15	5.65	5.65	6.65	6.65
B	13.6	17.1	17.1	19.1	19.1
C	13.6	17.1	17.1	19.1	19.1
E	3.3	5.8	5.8	5.8	5.8
L	13.5	16.5	21.5	16.5	21.5
H	1.0 to 1.4	1.0 to 1.4	1.0 to 1.4	1.0 to 1.4	1.0 to 1.4

Type numbering system (Example : 63V 240μF)

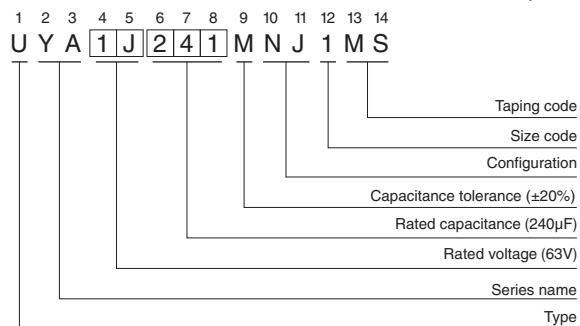

Frequency coefficient of rated ripple current

Frequency	50Hz	120Hz	300Hz	1kHz	10kHz or more
Coefficient	0.35	0.50	0.64	0.83	1.00

● Dimension table in next page.

UYA

■ Dimensions

Rated Voltage (V) (code)	Rated Capacitance (μ F)	Case Size ϕ D \times L (mm)	tan δ	Leakage Current (μ A) (at 20°C after 2 minutes)	Rated Ripple (mArms) (125°C/100kHz)	Part Number
63 (1J)	240	12.5 \times 13.5	0.12	151.2	650	UYA1J241MNJ1MS
	430	16 \times 16.5	0.12	270.9	930	UYA1J431MNJ1MS
	560	18 \times 16.5	0.12	352.8	1000	UYA1J561MNJ1MS
	660	16 \times 21.5	0.12	415.8	1500	UYA1J661MNJ1MS
	880	18 \times 21.5	0.12	554.4	1600	UYA1J881MNJ1MS
80 (1K)	160	12.5 \times 13.5	0.12	128	650	UYA1K161MNJ1MS
	270	16 \times 16.5	0.12	216	930	UYA1K271MNJ1MS
	360	18 \times 16.5	0.12	288	1000	UYA1K361MNJ1MS
	430	16 \times 21.5	0.12	344	1500	UYA1K431MNJ1MS
	560	18 \times 21.5	0.12	448	1600	UYA1K561MNJ1MS
100 (2A)	90	12.5 \times 13.5	0.10	90	650	UYA2A900MNJ1MS
	160	16 \times 16.5	0.10	160	930	UYA2A161MNJ1MS
	200	18 \times 16.5	0.10	200	1000	UYA2A201MNJ1MS
	240	16 \times 21.5	0.10	240	1500	UYA2A241MNJ1MS
	330	18 \times 21.5	0.10	330	1600	UYA2A331MNJ1MS

ALUMINUM ELECTROLYTIC CAPACITORS

UCH

Chip Type, High Reliability.
Low temperature ESR specification.



- Added ESR specification after the test at -40°C.
- Applicable to automatic mounting machine fed with carrier tape.
- Compliant to the RoHS directive (2011/65/EU, (EU)2015/863).
- AEC-Q200 compliant. Please contact us for details.

UCH ← Low ESR **UCZ**



Specifications

Item	Performance Characteristics												
Category Temperature Range	-40 to +125°C												
Rated Voltage Range	25 to 63V												
Rated Capacitance Range	33 to 560μF												
Capacitance Tolerance	±20% at 120Hz, 20°C												
Leakage Current ※	After 2 minutes' application of rated voltage at 20°C, leakage current is not more than 0.01CV (μA).												
Tangent of loss angle (tan δ)	<table border="1"> <tr> <td>Rated voltage (V)</td> <td>25</td> <td>35</td> <td>50</td> <td>63</td> </tr> <tr> <td>tan δ (max.)</td> <td>0.18</td> <td>0.16</td> <td>0.16</td> <td>0.14</td> </tr> </table>	Rated voltage (V)	25	35	50	63	tan δ (max.)	0.18	0.16	0.16	0.14	Measurement frequency : 120Hz at 20°C	
Rated voltage (V)	25	35	50	63									
tan δ (max.)	0.18	0.16	0.16	0.14									
Stability at Low Temperature	<table border="1"> <tr> <td>Rated voltage (V)</td> <td>25</td> <td>35</td> <td>50</td> <td>63</td> </tr> <tr> <td>Impedance ratio ZT / Z20 (max.)</td> <td>Z(-40°C) / Z(+20°C)</td> <td>3</td> <td>3</td> <td>3</td> <td>3</td> </tr> </table>	Rated voltage (V)	25	35	50	63	Impedance ratio ZT / Z20 (max.)	Z(-40°C) / Z(+20°C)	3	3	3	3	Measurement frequency : 120Hz
Rated voltage (V)	25	35	50	63									
Impedance ratio ZT / Z20 (max.)	Z(-40°C) / Z(+20°C)	3	3	3	3								
Endurance	The specifications listed at right shall be met when the capacitors are restored to 20°C after the rated voltage is applied for 2000 hours at 125°C.	<table border="1"> <tr> <td>Capacitance change</td> <td>Within ±30% of the initial capacitance value</td> </tr> <tr> <td>tan δ</td> <td>300% or less than the initial specified value</td> </tr> <tr> <td>Leakage current</td> <td>Less than or equal to the initial specified value</td> </tr> </table>	Capacitance change	Within ±30% of the initial capacitance value	tan δ	300% or less than the initial specified value	Leakage current	Less than or equal to the initial specified value					
Capacitance change	Within ±30% of the initial capacitance value												
tan δ	300% or less than the initial specified value												
Leakage current	Less than or equal to the initial specified value												
Shelf Life	After storing the capacitors under no load at 125°C for 1000 hours and then performing voltage treatment based on JIS C 5101-4 clause 4.1 at 20°C, they shall meet the specified values for the endurance characteristics listed above.												
Resistance to soldering heat	The capacitors are kept on a hot plate for 30 seconds, which is maintained at 250°C. The capacitors shall meet the characteristic requirements listed at right when they are removed from the plate and restored to 20°C.	<table border="1"> <tr> <td>Capacitance change</td> <td>Within ±10% of the initial capacitance value</td> </tr> <tr> <td>tan δ</td> <td>Less than or equal to the initial specified value</td> </tr> <tr> <td>Leakage current</td> <td>Less than or equal to the initial specified value</td> </tr> </table>	Capacitance change	Within ±10% of the initial capacitance value	tan δ	Less than or equal to the initial specified value	Leakage current	Less than or equal to the initial specified value					
Capacitance change	Within ±10% of the initial capacitance value												
tan δ	Less than or equal to the initial specified value												
Leakage current	Less than or equal to the initial specified value												
Marking	Black print on the case top.												

※ I : Leakage Current (μA), C : Rated Capacitance (μF), V : Rated Voltage (V)

Chip Type

(φ6.3) 【Standard】

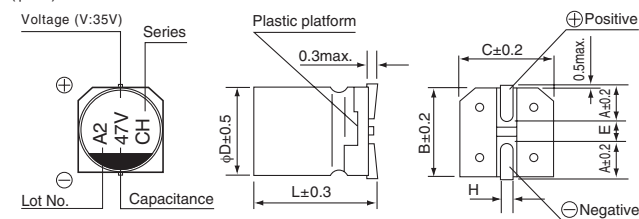

(φ8, φ10) 【Standard】

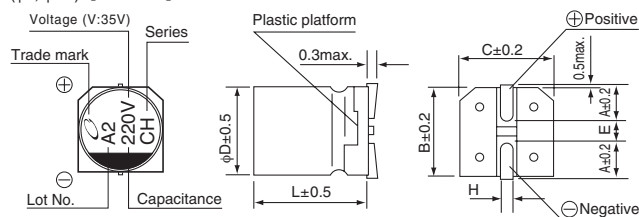

(φ6.3) 【Vibration Resistance】

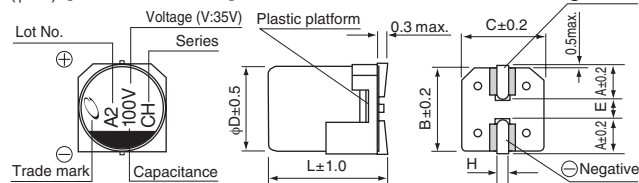

Type numbering system (Example : 35V 47μF)

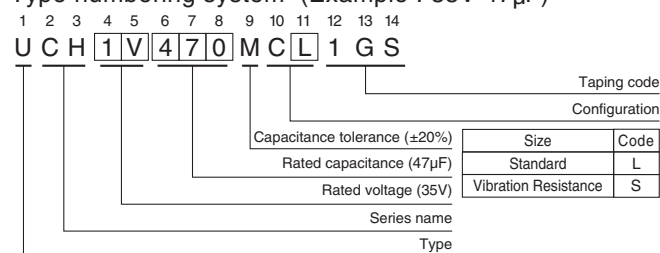

(φ8, φ10) 【Vibration Resistance】

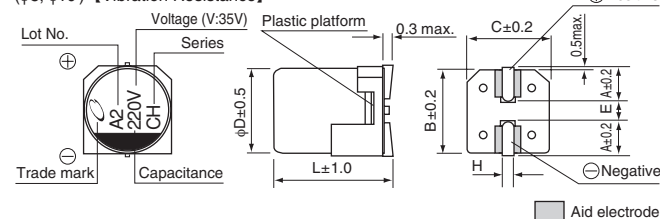

Voltage	Standard (mm)			Vibration Resistance (mm)		
	V	25	35	50	63	Code
Code	E	V	H	J		
φd	A	2.4	2.9	3.2		
	B	6.6	8.3	10.3		
φd	C	6.6	8.3	10.3		
	E	2.2	3.1	4.5		
φd	L	7.7	10	10		
	H	0.5 to 0.8	0.8 to 1.1	0.8 to 1.1		
φd	A	2.4	2.9	3.2		
	B	6.6	8.3	10.3		
φd	C	6.6	8.3	10.3		
	E	2.2	3.1	4.5		
φd	L	7.7	10	10		
	H	0.5 to 0.8	1.1 to 1.5	1.1 to 1.5		

● Frequency coefficient of rated ripple current

Frequency	50Hz	120Hz	300Hz	1kHz	10kHz or more
Coefficient	0.35	0.50	0.64	0.83	1.00

● Dimension table in next page.

UCH

■ Dimensions

Rated Voltage (V) (code)	Rated Capacitance (μ F)	Case Size ϕ D \times L (mm)	tan δ	Leakage Current (μ A) (at 20°C after 2 minutes)	ESR (Ω) max.			Rated Ripple (mArms) (125°C/100kHz)	Part Number
					Initial 20°C 100kHz	Initial -40°C 100kHz	after endurance test 2000hours -40°C 400kHz		
25 (1E)	150	6.3 \times 7.7	0.18	37.5	0.30	3.0	6.0	197	UCH1E151MC□1GS
	330	8 \times 10	0.18	82.5	0.20	2.0	4.5	270	UCH1E331MC□1GS
	560	10 \times 10	0.18	140	0.15	1.5	3.5	500	UCH1E561MC□1GS
35 (1V)	47	6.3 \times 7.7	0.16	16.45	0.30	3.0	6.0	197	UCH1V470MC□1GS
	100	6.3 \times 7.7	0.16	35	0.30	3.0	6.0	197	UCH1V101MC□1GS
	220	8 \times 10	0.16	77	0.20	2.0	4.5	270	UCH1V221MC□1GS
	330	10 \times 10	0.16	115.5	0.15	1.5	3.5	500	UCH1V331MC□1GS
50 (1H)	47	6.3 \times 7.7	0.16	23.5	0.80	8.0	—	150	UCH1H470MC□1GS
	100	8 \times 10	0.16	50	0.40	6.0	—	250	UCH1H101MC□1GS
	220	10 \times 10	0.16	110	0.25	3.0	—	400	UCH1H221MC□1GS
63 (1J)	33	6.3 \times 7.7	0.14	20.79	0.80	8.0	—	150	UCH1J330MC□1GS
	68	8 \times 10	0.14	42.84	0.40	6.0	—	250	UCH1J680MC□1GS
	100	10 \times 10	0.14	63	0.25	3.0	—	400	UCH1J101MC□1GS

□ : Enter the appropriate configuration code.

- For taping specifications, recommended land size/soldering by reflow and minimum order quantity, please refer to the Guidelines for Aluminum Electrolytic Capacitors.

ALUMINUM ELECTROLYTIC CAPACITORS

UCX Chip Type, High Reliability Low temperature ESR specification



- Chip type, high temperature range, for +135°C use.
- Added ESR specification after the test at -40°C.
- Applicable to automatic mounting machine fed with carrier tape.
- Compliant to the RoHS directive (2011/65/EU, (EU)2015/863).
- AEC-Q200 compliant. Please contact us for details.

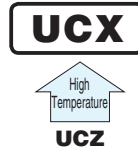

Specifications

Item	Performance Characteristics													
Category Temperature Range	-40 to +135°C													
Rated Voltage Range	10 to 50V													
Rated Capacitance Range	47 to 3300μF													
Capacitance Tolerance	±20% at 120Hz, 20°C													
Leakage Current ※	After 2 minutes' application of rated voltage at 20°C, leakage current is not more than 0.01CV or 3(μA), whichever is greater.													
Tangent of loss angle (tan δ)	<table border="1"> <tr> <td>Rated voltage (V)</td> <td>10</td> <td>16</td> <td>25</td> <td>35</td> <td>50</td> </tr> <tr> <td>tan δ (max.)</td> <td>0.30</td> <td>0.23</td> <td>0.18</td> <td>0.16</td> <td>0.16</td> </tr> </table> <p>Measurement frequency : 120Hz at 20°C</p>	Rated voltage (V)	10	16	25	35	50	tan δ (max.)	0.30	0.23	0.18	0.16	0.16	
	Rated voltage (V)	10	16	25	35	50								
tan δ (max.)	0.30	0.23	0.18	0.16	0.16									
For capacitance of more than 1000μF, add 0.02 for every increase of 1000μF. (φ12.5 to φ18)														
Stability at Low Temperature	<table border="1"> <tr> <td>Rated voltage (V)</td> <td>10</td> <td>16</td> <td>25</td> <td>35</td> <td>50</td> </tr> <tr> <td>Impedance ratio (max.)</td> <td>Z(-40°C) / Z(+20°C)</td> <td>12</td> <td>8</td> <td>6</td> <td>4</td> <td>4</td> </tr> </table> <p>Measurement frequency : 120Hz</p>	Rated voltage (V)	10	16	25	35	50	Impedance ratio (max.)	Z(-40°C) / Z(+20°C)	12	8	6	4	4
	Rated voltage (V)	10	16	25	35	50								
Impedance ratio (max.)	Z(-40°C) / Z(+20°C)	12	8	6	4	4								
The specifications listed at right shall be met when the capacitors are restored to 20°C after the rated voltage is applied for 2000 hours at 135°C.														
Endurance	<table border="1"> <tr> <td>Capacitance Change</td> <td>Within ±30% of the initial capacitance value</td> </tr> <tr> <td>tan δ</td> <td>300% or less than the initial specified value</td> </tr> <tr> <td>Leakage current</td> <td>Less than or equal to the initial specified value</td> </tr> </table>	Capacitance Change	Within ±30% of the initial capacitance value	tan δ	300% or less than the initial specified value	Leakage current	Less than or equal to the initial specified value							
Capacitance Change	Within ±30% of the initial capacitance value													
tan δ	300% or less than the initial specified value													
Leakage current	Less than or equal to the initial specified value													
Shelf Life	After storing the capacitors under no load at 135°C for 1000 hours and then performing voltage treatment based on JIS C 5101-4 clause 4.1 at 20°C, they shall meet the specified values for the endurance characteristics listed above.													
Resistance to soldering heat	The capacitors shall be kept on the hot plate for 30 seconds, which is maintained at 250°C. The capacitors shall meet the characteristic requirements listed at right when they are removed from the plate and restored to 20°C.													
	<table border="1"> <tr> <td>Capacitance Change</td> <td>Within ±10% of the initial capacitance value</td> </tr> <tr> <td>tan δ</td> <td>Less than or equal to the initial specified value</td> </tr> <tr> <td>Leakage current</td> <td>Less than or equal to the initial specified value</td> </tr> </table>	Capacitance Change	Within ±10% of the initial capacitance value	tan δ	Less than or equal to the initial specified value	Leakage current	Less than or equal to the initial specified value							
Capacitance Change	Within ±10% of the initial capacitance value													
tan δ	Less than or equal to the initial specified value													
Leakage current	Less than or equal to the initial specified value													
Marking	Black print on the case top.													

Chip Type

(φ6.3)【Vibration Resistance】

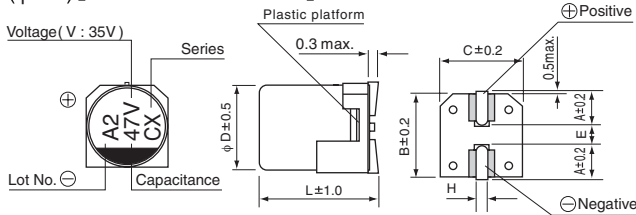

※ φ6.3 × 10 : Vibration resistant type only

(φ8, φ10)【Standard】

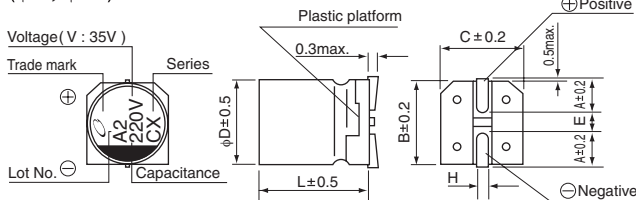

(φ12.5 to φ18)【Standard】

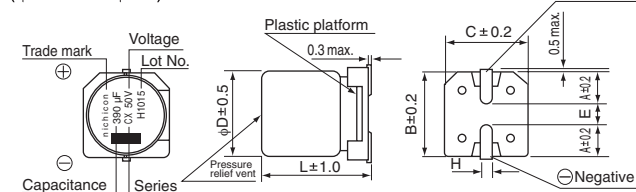

※ I : Leakage Current (μA), C : Rated Capacitance (μF), V : Rated Voltage (V)

Type numbering system (Example : 35V 47μF)

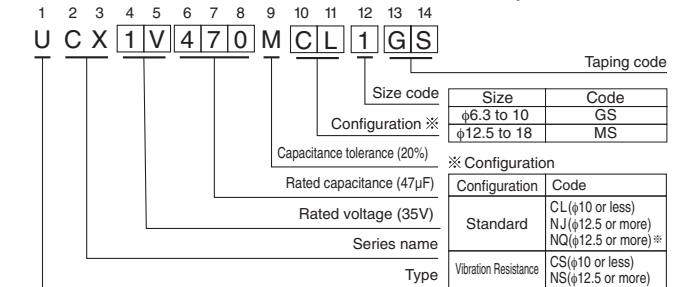

(φ8, φ10)【Vibration Resistance】

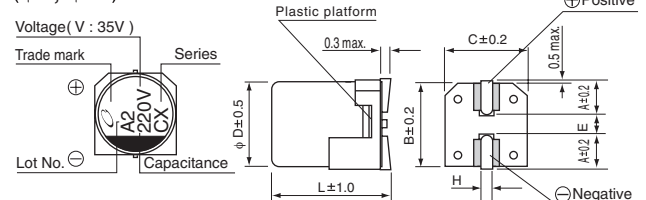

(φ12.5 to φ18)【Vibration Resistance】

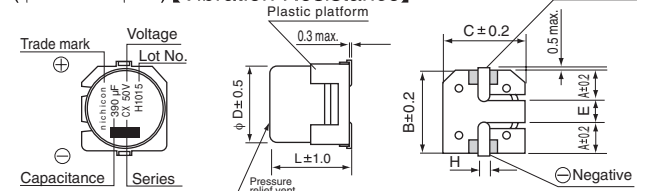

Standard

φD×L	8×10	10×10	12.5×13.5	16×16.5	21.5	18×16.5	21.5
A	2.9	3.2	5.15	5.65	6.65		
B	8.3	10.3	13.6	17.1	19.1		
C	8.3	10.3	13.6	17.1	19.1		
E	3.1	4.5	(3.3)	(5.8)	(5.8)		
L	10	10	13.5	16.5, 21.5	16.5, 21.5		
H	0.8 to 1.1	0.8 to 1.1	1.0 to 1.4	1.0 to 1.4	1.0 to 1.4		

Vibration Resistance

φD×L	6.3×10	8×10	10×10	12.5×13.5	16×16.5	21.5	18×16.5	21.5
A	2.4	2.9	3.2	4.8	5.4	6.4		
B	6.6	8.3	10.3	13.6	17.1	19.1		
C	6.6	8.3	10.3	13.6	17.1	19.1		
E	2.2	3.1	4.5	(4.0)	(6.3)	(6.3)		
L	10	10	10	13.5	16.5, 21.5	16.5, 21.5		
H	0.5 to 0.8	1.1 to 1.5	1.1 to 1.5	1.0 to 1.4	1.0 to 1.4	1.0 to 1.4		

Voltage

V	10	16	25	35	50
Code	A	C	E	V	H

■ Aid electrode

Frequency coefficient of rated ripple current

Frequency	50Hz	120Hz	300Hz	1kHz	10kHz or more
Coefficient	0.35	0.50	0.64	0.83	1.00

Please contact us for the dimensions for NQ.

● Dimension table in next page.



■ Dimensions

Rated Voltage (V) (code)	Rated Capacitance (μF)	Case Size φD×L (mm)	tan δ	Leakage Current (μA) (at 20°C after 2 minutes)	ESR (Ω) max. (20°C/−40°C/100kHz)			Rated Ripple (mArms) (135°C/100kHz)	Part Number
					Initial 20°C	Initial −40°C	after endurance test 1000hours −40°C		
10 (1A)	220	8×10	0.30	22	0.20	3.00	12	270	UCX1A221M□□1GS
	330	8×10	0.30	33	0.20	3.00	12	270	UCX1A331M□□6GS
	330	10×10	0.30	33	0.15	2.00	10	500	UCX1A331M□□1GS
	470	10×10	0.30	47	0.15	2.00	10	500	UCX1A471M□□1GS
16 (1C)	100	6.3×10	0.23	16	0.25	4.00	15	197	UCX1C101MCS6GS
	100	8×10	0.23	16	0.20	3.00	12	270	UCX1C101M□□1GS
	220	8×10	0.23	35.2	0.20	3.00	12	270	UCX1C221M□□1GS
	330	10×10	0.23	52.8	0.15	2.00	10	500	UCX1C331M□□1GS
	470	10×10	0.23	75.2	0.15	2.00	10	500	UCX1C471M□□1GS
25 (1E)	100	8×10	0.18	25	0.20	3.00	12	270	UCX1E101M□□1GS
	220	10×10	0.18	55	0.15	2.00	10	500	UCX1E221M□□1GS
	330	10×10	0.18	82.5	0.15	2.00	10	500	UCX1E331M□□1GS
	820	12.5×13.5	0.18	205	0.070	1.00	5.0	750	UCX1E821M□□1MS
	1000	12.5×13.5	0.18	250	0.070	1.00	5.0	750	UCX1E102M□□1MS
	1200	16×16.5	0.18	300	0.050	0.50	2.5	1200	UCX1E122M□□1MS
	1500	16×16.5	0.18	375	0.050	0.50	2.5	1200	UCX1E152M□□1MS
	1800	16×16.5	0.18	450	0.050	0.50	2.5	1200	UCX1E182M□□1MS
	2200	18×16.5	0.20	550	0.050	0.50	2.5	1400	UCX1E222M□□1MS
	2700	16×21.5	0.20	675	0.040	0.32	1.6	1900	UCX1E272M□□1MS
35 (1V)	3300	18×21.5	0.22	825	0.035	0.28	1.4	2200	UCX1E332M□□1MS
	47	6.3×10	0.16	16.45	0.25	4.00	15	197	UCX1V470MCS6GS
	47	8×10	0.16	16.45	0.20	3.00	12	270	UCX1V470M□□1GS
	68	8×10	0.16	23.8	0.20	3.00	12	270	UCX1V680M□□1GS
	100	6.3×10	0.16	35	0.25	4.00	15	197	UCX1V101MCS6GS
	100	8×10	0.16	35	0.20	3.00	12	270	UCX1V101M□□1GS
	220	10×10	0.16	77	0.15	2.00	10	500	UCX1V221M□□1GS
	470	12.5×13.5	0.16	164.5	0.070	1.00	5.0	750	UCX1V471M□□1MS
	560	12.5×13.5	0.16	196	0.070	1.00	5.0	750	UCX1V561M□□1MS
	680	12.5×13.5	0.16	238	0.070	1.00	5.0	750	UCX1V681M□□1MS
	820	16×16.5	0.16	287	0.050	0.50	2.5	1200	UCX1V821M□□1MS
	1000	16×16.5	0.16	350	0.050	0.50	2.5	1200	UCX1V102M□□1MS
	1200	18×16.5	0.16	420	0.050	0.50	2.5	1400	UCX1V122M□□1MS
	1500	16×21.5	0.16	525	0.040	0.32	1.6	1900	UCX1V152M□□6MS
	1500	18×16.5	0.16	525	0.050	0.50	2.5	1400	UCX1V152M□□1MS
1800	18×21.5	0.16	630	0.035	0.28	1.4	2200	UCX1V182M□□1MS	
2200	18×21.5	0.18	770	0.035	0.28	1.4	2200	UCX1V222M□□1MS	
50 (1H)	47	8×10	0.16	23.5	0.25	3.50	15	270	UCX1H470M□□1GS
	100	10×10	0.16	50	0.20	2.50	12	500	UCX1H101M□□1GS
	390	12.5×13.5	0.16	195	0.090	1.30	6.5	750	UCX1H391M□□1MS
	470	16×16.5	0.16	235	0.070	0.70	3.5	1000	UCX1H471M□□1MS
	560	16×16.5	0.16	280	0.070	0.70	3.5	1000	UCX1H561M□□1MS
	680	18×16.5	0.16	340	0.070	0.70	3.5	1200	UCX1H681M□□1MS
	820	18×16.5	0.16	410	0.070	0.70	3.5	1200	UCX1H821M□□1MS
	1000	16×21.5	0.16	500	0.050	0.40	2.0	1600	UCX1H102M□□1MS
1200	18×21.5	0.16	600	0.040	0.32	1.6	1900	UCX1H122M□□1MS	

□□ : Enter the appropriate configuration code.

• For taping specifications, recommended land size/soldering by reflow and minimum order quantity, please refer to the Guidelines for Aluminum Electrolytic Capacitors.

ALUMINUM ELECTROLYTIC CAPACITORS

UUR

Chip Type, High CV



- Chip type, higher capacitance.
- Designed for surface mounting on high density PC board.
- Applicable to automatic mounting machine fed with carrier tape.
- Compliant to the RoHS directive (2011/65/EU, (EU)2015/863).
- AEC-Q200 compliant. Please contact us for details.

Products which are scheduled to be discontinued.
Not recommended for new designs.

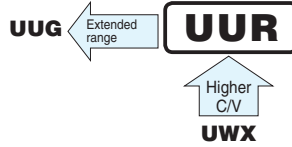

Specifications

Item	Performance Characteristics									
Category Temperature Range	-40 to +85°C									
Rated Voltage Range	4 to 100V									
Rated Capacitance Range	3.3 to 1500μF									
Capacitance Tolerance	±20% at 120Hz, 20°C									
Leakage Current ※	After 1 minute's application of rated voltage at 20°C, leakage current is not more than 0.03CV (μA).									
Tangent of loss angle (tan δ)	Measurement frequency : 120Hz at 20°C									
	Rated voltage (V)	4	6.3	10	16	25	35	50	63	100
	tan δ (max.)	0.35	0.28	0.24	0.20	0.16	0.14	0.12	0.12	0.12
Stability at Low Temperature	Measurement frequency: 120Hz									
	Rated voltage (V)	4	6.3	10	16	25	35	50	63	100
	Impedance ratio Z(-25°C) / Z(+20°C)	7	5	4	3	2	2	2	2	2
	ZT / Z20 (max.)	Z(-40°C) / Z(+20°C)	15	10	8	6	4	3	3	3
Endurance	The specifications listed at right shall be met when the capacitors are restored to 20°C after the rated voltage is applied for 2000 hours at 85°C.									
	Capacitance change	Within ±20% of the initial capacitance value								
	tan δ	200% or less than the initial specified value								
	Leakage current	Less than or equal to the initial specified value								
Shelf Life	After storing the capacitors under no load at 85°C for 1000 hours and then performing voltage treatment based on JIS C 5101-4 clause 4.1 at 20°C, they shall meet the specified values for the endurance characteristics listed above.									
Resistance to soldering heat	The capacitors are kept on a hot plate for 30 seconds, which is maintained at 250°C. The capacitors shall meet the characteristic requirements listed at right when they are removed from the plate and restored to 20°C.									
	Capacitance change	Within ±10% of the initial capacitance value								
	tan δ	Less than or equal to the initial specified value								
	Leakage current	Less than or equal to the initial specified value								
Marking	Black print on the case top.									

※ I : Leakage Current (μA), C : Rated Capacitance (μF), V : Rated Voltage (V)

Chip Type

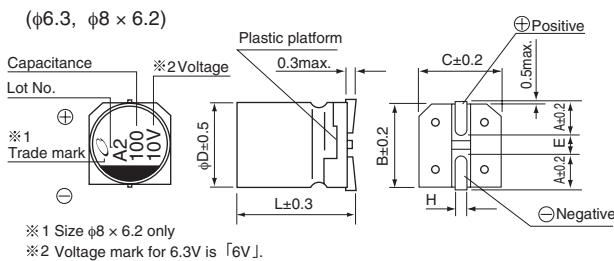

Type numbering system (Example : 10V 100μF)

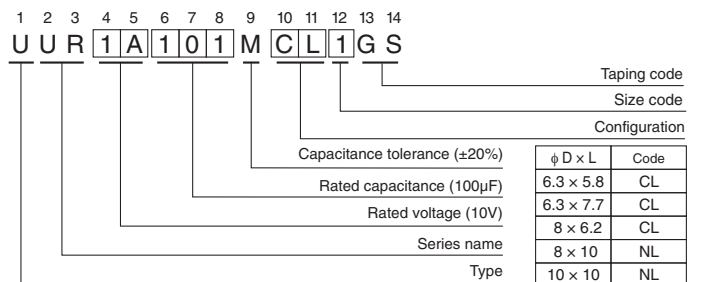

(φ8 × 10, φ10)

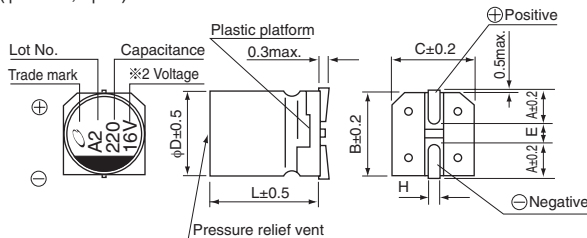

	(mm)				
φD × L	6.3 × 5.8	6.3 × 7.7	8 × 6.2	8 × 10	10 × 10
A	2.4	2.4	3.3	2.9	3.2
B	6.6	6.6	8.3	8.3	10.3
C	6.6	6.6	8.3	8.3	10.3
E	2.2	2.2	2.3	3.1	4.5
L	5.8	7.7	6.2	10	10
H	0.5 to 0.8	0.5 to 0.8	0.5 to 0.8	0.8 to 1.1	0.8 to 1.1

Frequency coefficient of rated ripple current

Cap. (μF)	Frequency	50 Hz	120 Hz	300 Hz	1 kHz	10 kHz or more
Less than 47		0.80	1.00	1.15	1.40	1.67
100 to 1500		0.85	1.00	1.08	1.20	1.30

● Dimension table in next page.

UUR

■ Dimensions

Rated Voltage (V) (code)	Rated Capacitance (μF)	Case Size φD×L (mm)	tan δ	Leakage Current (μA) (at 20°C after 1 minute)	Rated Ripple (mArms) (85°C/120Hz)	Part Number
4 (0G)	330	6.3×5.8	0.35	39.6	152	UUR0G331MCL1GS
	470	6.3×7.7	0.35	56.4	200	UUR0G471MCL1GS
	680	8×10	0.35	81.6	284	UUR0G681MNL1GS
	1000	8×10	0.35	120	344	UUR0G102MNL1GS
	1500	10×10	0.35	180	347	UUR0G152MNL1GS
6.3 (0J)	220	8×6.2	0.28	41.58	160	UUR0J221MCL1GS
	220	6.3×5.8	0.28	41.58	143	UUR0J221MCL6GS
	330	8×6.2	0.28	62.37	190	UUR0J331MCL1GS
	330	6.3×7.7	0.28	62.37	188	UUR0J331MCL6GS
	470	8×10	0.28	88.83	265	UUR0J471MNL1GS
	680	8×10	0.28	128.52	318	UUR0J681MNL1GS
	1000	10×10	0.28	189	400	UUR0J102MNL1GS
	1000	8×10	0.28	189	372	UUR0J102MNL6GS
	1500	10×10	0.28	283.5	489	UUR0J152MNL1GS
10 (1A)	100	6.3×5.8	0.24	30	70	UUR1A101MCL1GS
	150	6.3×5.8	0.24	45	85	UUR1A151MCL1GS
	220	8×6.2	0.24	66	175	UUR1A221MCL1GS
	220	6.3×7.7	0.24	66	173	UUR1A221MCL6GS
	330	8×10	0.24	99	240	UUR1A331MNL1GS
	470	8×10	0.24	141	290	UUR1A471MNL1GS
	680	10×10	0.24	204	374	UUR1A681MNL1GS
	1000	10×10	0.24	300	454	UUR1A102MNL1GS
16 (1C)	100	8×6.2	0.20	48	125	UUR1C101MCL1GS
	150	6.3×7.7	0.20	72	151	UUR1C151MCL1GS
	220	8×10	0.20	105.6	215	UUR1C221MNL1GS
	220	6.3×7.7	0.20	105.6	162	UUR1C221MCL6GS
	330	8×10	0.20	158.4	270	UUR1C331MNL1GS
	470	10×10	0.20	225.6	330	UUR1C471MNL1GS
	470	8×10	0.20	225.6	307	UUR1C471MNL6GS
	680	10×10	0.20	326.4	396	UUR1C681MNL1GS
25 (1E)	47	6.3×5.8	0.16	35.25	65	UUR1E470MCL1GS
	100	8×6.2	0.16	75	145	UUR1E101MCL1GS
	100	6.3×7.7	0.16	75	143	UUR1E101MCL6GS
	150	8×10	0.16	112.5	192	UUR1E151MNL1GS
	220	10×10	0.16	165	250	UUR1E221MNL1GS
	220	8×10	0.16	165	232	UUR1E221MNL6GS
	330	10×10	0.16	247.5	305	UUR1E331MNL1GS
	330	8×10	0.16	247.5	284	UUR1E331MNL6GS
	470	10×10	0.16	352.5	393	UUR1E471MNL1GS
35 (1V)	33	6.3×5.8	0.14	34.65	55	UUR1V330MCL1GS
	47	8×6.2	0.14	49.35	105	UUR1V470MCL1GS
	47	6.3×5.8	0.14	49.35	94	UUR1V470MCL6GS
	100	8×10	0.14	105	175	UUR1V101MNL1GS
	100	6.3×7.7	0.14	105	132	UUR1V101MCL6GS
	150	8×10	0.14	157.5	214	UUR1V151MNL1GS
	220	10×10	0.14	231	265	UUR1V221MNL1GS
	220	8×10	0.14	231	246	UUR1V221MNL6GS
	330	10×10	0.14	346.5	324	UUR1V331MNL1GS

UUR

■ Dimensions

Rated Voltage (V) (code)	Rated Capacitance (μ F)	Case Size ϕ D \times L (mm)	$\tan \delta$	Leakage Current (μ A) (at 20°C after 1 minute)	Rated Ripple (mArms) (85°C/120Hz)	Part Number
50 (1H)	22	6.3 \times 5.8	0.12	33	45	UUR1H220MCL1GS
	33	8 \times 6.2	0.12	49.5	95	UUR1H330MCL1GS
	33	6.3 \times 7.7	0.12	49.5	94	UUR1H330MCL6GS
	47	8 \times 10	0.12	70.5	140	UUR1H470MNL1GS
	47	6.3 \times 7.7	0.12	70.5	105	UUR1H470MCL6GS
	100	10 \times 10	0.12	150	195	UUR1H101MNL1GS
	100	8 \times 10	0.12	150	181	UUR1H101MNL6GS
	150	10 \times 10	0.12	225	238	UUR1H151MNL1GS
	220	10 \times 10	0.12	330	289	UUR1H221MNL1GS
63 (1J)	4.7	6.3 \times 5.8	0.12	8.883	31	UUR1J4R7MCL1GS
	10	8 \times 6.2	0.12	18.9	46	UUR1J100MCL1GS
	22	8 \times 10	0.12	41.58	96	UUR1J220MNL1GS
	33	8 \times 10	0.12	62.37	117	UUR1J330MNL1GS
	47	8 \times 10	0.12	88.83	140	UUR1J470MNL1GS
	100	10 \times 10	0.12	189	232	UUR1J101MNL1GS
100 (2A)	3.3	6.3 \times 5.8	0.12	9.9	29	UUR2A3R3MCL1GS
	4.7	8 \times 6.2	0.12	14.1	40	UUR2A4R7MCL1GS
	4.7	6.3 \times 5.8	0.12	14.1	35	UUR2A4R7MCL6GS
	10	8 \times 10	0.12	30	77	UUR2A100MNL1GS
	22	8 \times 10	0.12	66	100	UUR2A220MNL1GS
	33	10 \times 10	0.12	99	130	UUR2A330MNL1GS
	47	10 \times 10	0.12	141	155	UUR2A470MNL1GS

- For taping specifications, recommended land size/soldering by reflow and minimum order quantity, please refer to the Guidelines for Aluminum Electrolytic Capacitors.
- Please select UUG if high C/V products are required.

ALUMINUM ELECTROLYTIC CAPACITORS

UUX

Chip Type, Wide Temperature Range

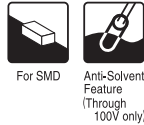

- Chip type, operating over wide temperature range of to -55 to +105°C.
- Designed for surface mounting on high density PC board.
- Applicable to automatic mounting machine fed with carrier tape.
- Compliant to the RoHS directive (2011/65/EU,(EU)2015/863).
- AEC-Q200 compliant. Please contact us for details.

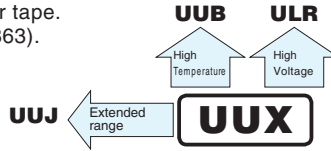

Specifications

Item	Performance Characteristics												
Category Temperature Range	-55 to +105°C (6.3 to 100V), -40 to +105°C (160 to 400V)												
Rated Voltage Range	6.3 to 400V												
Rated Capacitance Range	1 to 1000µF												
Capacitance Tolerance	±20% at 120Hz, 20°C												
Leakage Current ※	Rated voltage (V)	6.3 to 100										160 to 400	
	Leakage Current	After 1 minute's application of rated voltage at 20°C, leakage current is not more than 0.03CV (µA).										I = 0.04CV+100 (µA) max.(1 minute's at 20°C)	
Tangent of loss angle (tan δ)	Measurement frequency : 120Hz at 20°C												
	Rated voltage (V)	6.3	10	16	25	35	50	63	100	160	200	250	400
Stability at Low Temperature	Measurement frequency: 120Hz												
	Rated voltage (V)	6.3	10	16	25	35	50	63	100	160	200	250	400
Endurance	Impedance ratio Z(-55°C) / Z(+20°C)	4	4	3	3	3	2	3	4	—	—	—	—
	ZT / Z20 (max.)	Z(-40°C) / Z(+20°C)	—	—	—	—	—	—	—	6	6	6	10
Shelf Life	The specifications listed at right shall be met when the capacitors are restored to 20°C after the rated voltage is applied for 2000 hours (160 to 400V : 3000hours) at 105°C.												
	Capacitance change	Within ±20% of the initial capacitance value											
	tan δ	200% or less than the initial specified value											
Resistance to soldering heat	After storing the capacitors under no load at 105°C for 1000 hours and then performing voltage treatment based on JIS C 5101-4 clause 4.1 at 20°C, they shall meet the specified values for the endurance characteristics listed above.												
	Capacitance change	Within ±10% of the initial capacitance value											
	tan δ	Less than or equal to the initial specified value											
Marking	The capacitors are kept on a hot plate for 30 seconds, which is maintained at 250°C. The capacitors shall meet the characteristic requirements listed at right when they are removed from the plate and restored to 20°C.												
	Capacitance change	Less than or equal to the initial specified value											
Leakage current	Less than or equal to the initial specified value												
Marking	Black print on the case top.												

※ I : Leakage Current (µA), C : Rated Capacitance (µF), V : Rated Voltage (V)

Chip Type

Type numbering system (Example : 10V 100µF)

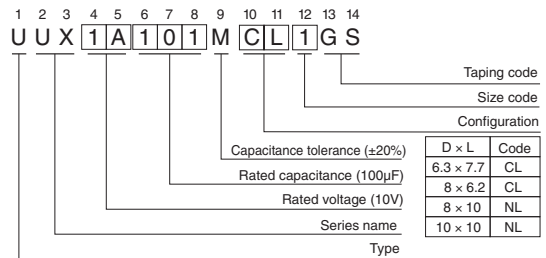
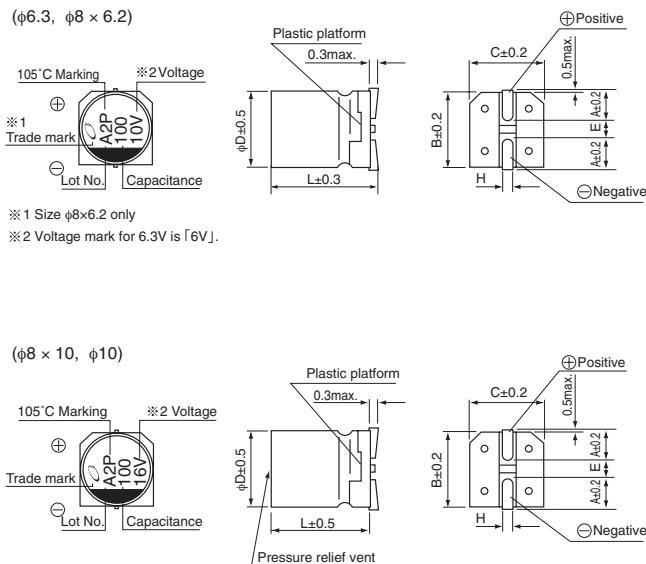

(mm)	φD × L	6.3 × 7.7	8 × 6.2	8 × 10	10 × 10
A		2.4	3.3	2.9	3.2
B		6.6	8.3	8.3	10.3
C		6.6	8.3	8.3	10.3
E		2.2	2.3	3.1	4.5
L		7.7	6.2	10	10
H		0.5 to 0.8	0.5 to 0.8	0.8 to 1.1	0.8 to 1.1

Frequency coefficient of rated ripple current

Cap.(µF)	Frequency	50 Hz	120 Hz	300 Hz	1 kHz	10 kHz or more
1 to 47		0.80	1.00	1.15	1.40	1.67
100 to 1000		0.85	1.00	1.08	1.20	1.30

● Dimension table in next page.

UUX

■ Dimensions

Rated Voltage (V) (code)	Rated Capacitance (μF)	Case Size φD×L (mm)	tan δ	Leakage Current (μA) (at 20°C after 1 minute)	Rated Ripple (mArms) (105°C/120Hz)	Part Number
6.3 (0J)	220	8×10	0.22	41.58	161	UUX0J221MNL1GS
	220	6.3×7.7	0.22	41.58	121	UUX0J221MCL6GS
	330	8×10	0.22	62.37	288	UUX0J331MNL1GS
	470	10×10	0.22	88.83	340	UUX0J471MNL1GS
	470	8×10	0.22	88.83	316	UUX0J471MNL6GS
	680	10×10	0.22	128.52	408	UUX0J681MNL1GS
	1000	10×10	0.22	189	495	UUX0J102MNL1GS
10 (1A)	100	8×6.2	0.19	30	90	UUX1A101MCL1GS
	220	8×10	0.19	66	173	UUX1A221MNL1GS
	330	10×10	0.19	99	318	UUX1A331MNL1GS
	330	8×10	0.19	99	296	UUX1A331MNL6GS
	470	10×10	0.19	141	351	UUX1A471MNL1GS
	470	8×10	0.19	141	326	UUX1A471MNL6GS
	680	10×10	0.19	204	392	UUX1A681MNL1GS
16 (1C)	100	8×10	0.16	48	148	UUX1C101MNL1GS
	100	6.3×7.7	0.16	48	111	UUX1C101MCL6GS
	220	10×10	0.16	105.6	330	UUX1C221MNL1GS
	220	8×10	0.16	105.6	307	UUX1C221MNL6GS
	330	10×10	0.16	158.4	441	UUX1C331MNL1GS
	330	8×10	0.16	158.4	410	UUX1C331MNL6GS
	470	10×10	0.16	225.6	489	UUX1C471MNL1GS
25 (1E)	47	8×6.2	0.14	35.25	79	UUX1E470MCL1GS
	47	6.3×7.7	0.14	35.25	78	UUX1E470MCL6GS
	100	8×10	0.14	75	181	UUX1E101MNL1GS
	220	10×10	0.14	165	351	UUX1E221MNL1GS
	220	8×10	0.14	165	283	UUX1E221MNL6GS
	330	10×10	0.14	247.5	372	UUX1E331MNL1GS
35 (1V)	33	8×6.2	0.12	34.65	76	UUX1V330MCL1GS
	33	6.3×7.7	0.12	34.65	75	UUX1V330MCL6GS
	47	8×10	0.12	49.35	124	UUX1V470MNL1GS
	100	10×10	0.12	105	304	UUX1V101MNL1GS
	100	8×10	0.12	105	283	UUX1V101MNL6GS
	220	10×10	0.12	231	450	UUX1V221MNL1GS
50 (1H)	22	8×6.2	0.10	33	67	UUX1H220MCL1GS
	22	6.3×7.7	0.10	33	64	UUX1H220MCL6GS
	33	8×10	0.10	49.5	133	UUX1H330MNL1GS
	47	10×10	0.10	70.5	180	UUX1H470MNL1GS
	47	8×10	0.10	70.5	167	UUX1H470MNL6GS
	100	10×10	0.10	150	310	UUX1H101MNL1GS
63 (1J)	10	8×6.2	0.10	18.9	51	UUX1J100MCL1GS
	22	8×10	0.10	41.58	108	UUX1J220MNL1GS
	33	10×10	0.10	62.37	185	UUX1J330MNL1GS
	33	8×10	0.10	62.37	179	UUX1J330MNL6GS
	47	10×10	0.10	88.83	220	UUX1J470MNL1GS
	100	10×10	0.10	189	320	UUX1J101MNL1GS

UUX

■ Dimensions

Rated Voltage (V) (code)	Rated Capacitance (μF)	Case Size φD×L (mm)	tan δ	Leakage Current (μA) (at 20°C after 1 minute)	Rated Ripple (mArms) (105°C/120Hz)	Part Number
100 (2A)	4.7	8×6.2	0.08	14.1	42	UUX2A4R7MNL1GS
	10	8×10	0.08	30	75	UUX2A100MNL1GS
	22	10×10	0.08	66	150	UUX2A220MNL1GS
	22	8×10	0.08	66	121	UUX2A220MNL6GS
	33	10×10	0.08	99	180	UUX2A330MNL1GS
	47	10×10	0.08	141	230	UUX2A470MNL1GS
160 (2C)	10	8×10	0.20	164	57	UUX2C100MNL1GS
	18	10×10	0.20	215.2	64	UUX2C180MNL1GS
200 (2D)	3.3	8×10	0.20	126.4	31	UUX2D3R3MNL1GS
	3.9	8×10	0.20	131.2	34	UUX2D3R9MNL1GS
	4.7	8×10	0.20	137.6	37	UUX2D4R7MNL1GS
	6.8	8×10	0.20	154.4	44	UUX2D6R8MNL1GS
	10	10×10	0.20	180	64	UUX2D100MNL1GS
250 (2E)	3.3	8×10	0.20	133	31	UUX2E3R3MNL1GS
	3.9	8×10	0.20	139	34	UUX2E3R9MNL1GS
	4.7	8×10	0.20	147	37	UUX2E4R7MNL1GS
	6.8	8×10	0.20	168	44	UUX2E6R8MNL1GS
	10	10×10	0.20	200	64	UUX2E100MNL1GS
400 (2G)	1	8×10	0.25	116	25	UUX2G010MNL1GS
	1.8	8×10	0.25	128.8	26	UUX2G1R8MNL1GS
	2.2	8×10	0.25	135.2	27	UUX2G2R2MNL1GS
	3.3	10×10	0.25	152.8	38	UUX2G3R3MNL1GS
	3.9	10×10	0.25	162.4	39	UUX2G3R9MNL1GS
	4.7	10×10	0.25	175.2	40	UUX2G4R7MNL1GS

- For taping specifications, recommended land size/soldering by reflow and minimum order quantity, please refer to the Guidelines for Aluminum Electrolytic Capacitors.
- Please select UUU if high C/V products are required.

ULR

Chip Type, High Voltage.



For SMD

- Chip Type, high Voltage.
- Applicable to automatic mounting machine using carrier tape.
- Compliant to the RoHS directive (2011/65/EU,(EU)2015/863).
- AEC-Q200 compliant. Please contact us for details.

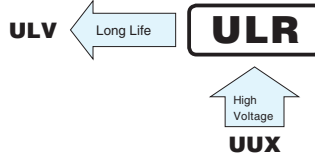

Specifications

Item	Performance Characteristics							
Category Temperature Range	-40 to +105°C							
Rated Voltage Range	160 to 500V							
Rated Capacitance Range	2.7 to 39μF							
Capacitance Tolerance	±20% at 120Hz, 20°C							
Leakage Current ※	After 1 minute's application of rated voltage at 20°C, leakage current is not more than 0.04CV +100(μA).							
Tangent of loss angle (tan δ)	Measurement frequency : 120Hz at 20°C							
	Rated voltage (V)	160	200	250	400	450	500	
Stability at Low Temperature	Measurement frequency: 120Hz							
	Rated voltage (V)	160	200	250	400	450	500	
Endurance	Impedance ratio ZT / Z20 (max.)	Z(-40°C) / Z(+20°C)	6	6	10	10	15	15
	The specifications listed at right shall be met when the capacitors are restored to 20°C after the rated voltage is applied for 3000 hours at 105°C.		Capacitance change		Within ±20% of the initial capacitance value			
Shelf Life	After storing the capacitors under no load at 105°C for 1000 hours and then performing voltage treatment based on JIS C 5101-4 clause 4.1 at 20°C, they shall meet the specified values for the endurance characteristics listed above.		tan δ		200% or less than the initial specified value			
	The capacitors are kept on a hot plate for 30 seconds, which is maintained at 250°C and then performing voltage treatment based on JIS C 5101-4 clause 4.1 at 20°C, they shall meet the characteristic requirements listed at right when they are removed from the plate.		Leakage current		Less than or equal to the initial specified value			
Resistance to soldering heat	The capacitors are kept on a hot plate for 30 seconds, which is maintained at 250°C and then performing voltage treatment based on JIS C 5101-4 clause 4.1 at 20°C, they shall meet the characteristic requirements listed at right when they are removed from the plate.		Capacitance change		Within ±10% of the initial capacitance value			
	Black print on the case top.		tan δ		Less than or equal to the initial specified value			
Marking	Black print on the case top.		Leakage current		Less than or equal to the initial specified value			

※ I : Leakage Current (μA), C : Rated Capacitance (μF), V : Rated Voltage (V)

Chip Type

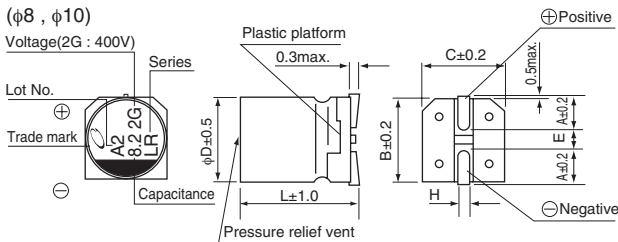

φD×L	8×10	10×10	10×13.5
A	2.9	3.2	3.2
B	8.3	10.3	10.3
C	8.3	10.3	10.3
E	3.1	4.5	4.5
L	10	10	13.5
H	0.8 to 1.1	0.8 to 1.1	0.8 to 1.1

V	160	200	250	400	450	500
Code	2C	2D	2E	2G	2W	2H

Type numbering system (Example : 400V 8.2μF)

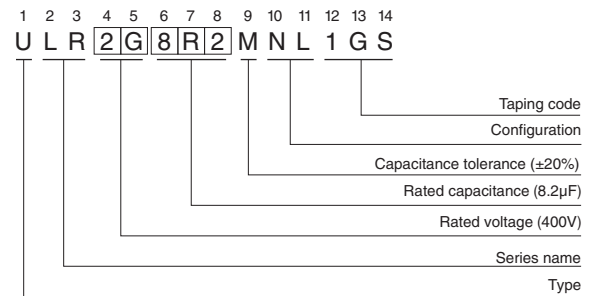

Frequency coefficient of rated ripple current

Frequency	50 Hz	120 Hz	300 Hz	1 kHz	10 kHz or more
Coefficient	0.80	1.00	1.25	1.40	1.60

● Dimension table in next page.

ULR

■ Dimensions

Rated Voltage (V) (code)	Rated Capacitance (μ F)	Case Size ϕ D \times L (mm)	tan δ	Leakage Current (μ A) (at 20°C after 1 minute)	Rated Ripple (mArms) (105°C/120Hz)	Part Number
160 (2C)	15	8 \times 10	0.20	196	50	ULR2C150MNL1GS
	27	10 \times 10	0.20	272.8	65	ULR2C270MNL1GS
	39	10 \times 13.5	0.20	349.6	70	ULR2C390MNL1GS
200 (2D)	12	8 \times 10	0.20	196	50	ULR2D120MNL1GS
	22	10 \times 10	0.20	276	65	ULR2D220MNL1GS
	33	10 \times 13.5	0.20	364	70	ULR2D330MNL1GS
250 (2E)	10	8 \times 10	0.25	200	35	ULR2E100MNL1GS
	15	10 \times 10	0.25	250	50	ULR2E150MNL1GS
	22	10 \times 13.5	0.25	320	55	ULR2E220MNL1GS
400 (2G)	4.7	8 \times 10	0.25	175.2	35	ULR2G4R7MNL1GS
	8.2	10 \times 10	0.25	231.2	50	ULR2G8R2MNL1GS
	12	10 \times 13.5	0.25	292	55	ULR2G120MNL1GS
450 (2W)	3.9	8 \times 10	0.30	170.2	25	ULR2W3R9MNL1GS
	6.8	10 \times 10	0.30	222.4	40	ULR2W6R8MNL1GS
	10	10 \times 13.5	0.30	280	45	ULR2W100MNL1GS
500 (2H)	2.7	8 \times 10	0.30	154	20	ULR2H2R7MNL1GS
	3.9	10 \times 10	0.30	178	35	ULR2H3R9MNL1GS
	5.6	10 \times 13.5	0.30	212	40	ULR2H5R6MNL1GS

- For taping specifications, recommended land size/soldering by reflow and minimum order quantity, please refer to the Guidelines for Aluminum Electrolytic Capacitors.

ALUMINUM ELECTROLYTIC CAPACITORS



Chip Type, High Voltage.
Long Life.



- Chip Type, high voltage and long life.
- Load life of 10000 hours at +105°C
- Applicable to automatic mounting machine using carrier tape.
- Compliant to the RoHS directive (2011/65/EU,(EU)2015/863).
- AEC-Q200 compliant. Please contact us for details.



Specifications

Item	Performance Characteristics	
Category Temperature Range	-40 to +105°C	
Rated Voltage Range	160 to 500V	
Rated Capacitance Range	1.8 to 33μF	
Capacitance Tolerance	±20% at 120Hz, 20°C	
Leakage Current ※	Rated voltage (V)	160 to 450
	-	0.04CV+100(μA)max.(1 minute's at 20°C)
Tangent of loss angle (tan δ)	500	
	0.04CV+200(μA)max.(1 minute's at 20°C)	
	Measurement frequency : 120Hz at 20°C	
Stability at Low Temperature	Rated voltage (V)	160 200 250 400 450 500
	tan δ (max.)	0.20 0.20 0.25 0.25 0.30 0.30
Endurance	The specifications listed at right shall be met when the capacitors are restored to 20°C after the rated voltage is applied for 10000 hours at 105°C.	
	Capacitance change	Within ±30% of the initial capacitance value
Shelf Life	tan δ	300% or less than the initial specified value
	Leakage current	Less than or equal to the initial specified value
Resistance to soldering heat	The capacitors are kept on a hot plate for 30 seconds, which is maintained at 250°C and then performing voltage treatment based on JIS C 5101-4 clause 4.1 at 20°C, they shall meet the characteristic requirements listed at right when they are removed from the plate.	
	Capacitance change	Within ±10% of the initial capacitance value
Marking	tan δ	Less than or equal to the initial specified value
	Leakage current	Less than or equal to the initial specified value
	Black print on the case top.	

※ I : Leakage Current (μA), C : Rated Capacitance (μF), V : Rated Voltage (V)

Chip Type

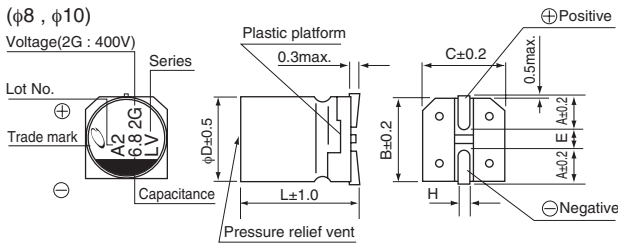

φxL (mm)	8x10	10x10	10x13.5
A	2.9	3.2	3.2
B	8.3	10.3	10.3
C	8.3	10.3	10.3
E	3.1	4.5	4.5
L	10	10	13.5
H	0.8 to 1.1	0.8 to 1.1	0.8 to 1.1

Voltage	
V	160 200 250 400 450 500
Code	2C 2D 2E 2G 2W 2H

Type numbering system (Example : 400V 6.8μF)

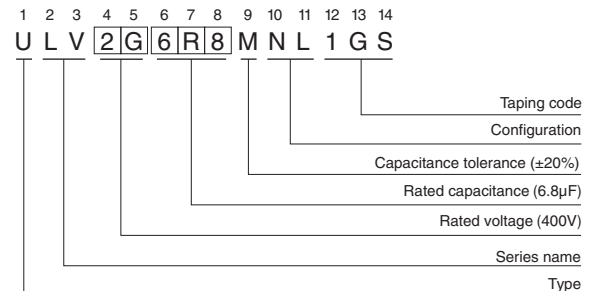

Frequency coefficient of rated ripple current

Frequency	50 Hz	120 Hz	300 Hz	1 kHz	10 kHz or more
Coefficient	0.80	1.00	1.25	1.40	1.60

● Dimension table in next page.

ULV

■ Dimensions

Rated Voltage (V) (code)	Rated Capacitance (μ F)	Case Size ϕ D \times L (mm)	$\tan \delta$	Leakage Current (μ A) (at 20°C after 1 minute)	Rated Ripple (mArms) (105°C/120Hz)	Part Number
160 (2C)	15	8 \times 10	0.20	196	50	ULV2C150MNL1GS
	22	10 \times 10	0.20	240.8	65	ULV2C220MNL1GS
	33	10 \times 13.5	0.20	311.2	70	ULV2C330MNL1GS
200 (2D)	12	8 \times 10	0.20	196	50	ULV2D120MNL1GS
	18	10 \times 10	0.20	244	65	ULV2D180MNL1GS
	27	10 \times 13.5	0.20	316	70	ULV2D270MNL1GS
250 (2E)	8.2	8 \times 10	0.25	182	35	ULV2E8R2MNL1GS
	15	10 \times 10	0.25	250	50	ULV2E150MNL1GS
	18	10 \times 13.5	0.25	280	55	ULV2E180MNL1GS
400 (2G)	3.9	8 \times 10	0.25	162.4	35	ULV2G3R9MNL1GS
	6.8	10 \times 10	0.25	208.8	50	ULV2G6R8MNL1GS
	10	10 \times 13.5	0.25	260	55	ULV2G100MNL1GS
450 (2W)	3.3	8 \times 10	0.30	159.4	25	ULV2W3R3MNL1GS
	5.6	10 \times 10	0.30	200.8	40	ULV2W5R6MNL1GS
	7.5	10 \times 13.5	0.30	235	45	ULV2W7R5MNL1GS
500 (2H)	1.8	8 \times 10	0.30	236	25	ULV2H1R8MNL1GS
	3.3	10 \times 10	0.30	266	40	ULV2H3R3MNL1GS
	4.7	10 \times 13.5	0.30	294	45	ULV2H4R7MNL1GS

- For taping specifications, recommended land size/soldering by reflow and minimum order quantity, please refer to the Guidelines for Aluminum Electrolytic Capacitors.

ALUMINUM ELECTROLYTIC CAPACITORS

UUG

Chip Type, Higher Capacitance Range



For SMD



Anti-Solvent Feature
(Through 100V only)

- Chip Type, higher capacitance in larger case sizes (φ12.5, φ16, φ18)
- Designed for surface mounting on high density PC board.
- Applicable to automatic mounting machine fed with carrier tape.
- Compliant to the RoHS directive (2011/65/EU,(EU)2015/863).
- AEC-Q200 compliant. Please contact us for details.

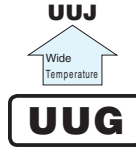

Specifications

Item	Performance Characteristics											
Category Temperature Range	-40 to +85°C											
Rated Voltage Range	6.3 to 450V											
Rated Capacitance Range	4.7 to 10000μF											
Capacitance Tolerance	±20% at 120Hz, 20°C											
Leakage Current ※	Rated voltage (V)	6.3 to 100							160 to 450			
	—	After 1 minute's application of rated voltage at 20°C, leakage current is not more than 0.03CV or 4 (μA), whichever is greater.							I = 0.04CV+100 (μA) max. (1 minute's at 20°C)			
Tangent of loss angle (tan δ)	Measurement frequency : 120Hz at 20°C											
	Rated voltage (V)	6.3	10	16	25	35	50	63	100	160 to 250	400 · 450	
	tan δ (max.)	0.28	0.24	0.20	0.16	0.14	0.12	0.10	0.08	0.20	0.25	
For capacitance of more than 1000μF, add 0.02 for every increase of 1000μF. (φ12.5 to φ18)												
Stability at Low Temperature	Measurement frequency: 120Hz											
	Rated voltage (V)	6.3	10	16	25	35	50	63	100	160 to 250	400 · 450	
	Impedance ratio (max.)	Z(-25°C) / Z(+20°C)	5	4	3	2	2	2	2	2	3	6
Endurance	The specifications listed at right shall be met when the capacitors are restored to 20°C after the rated voltage is applied for 2000 hours at 85°C.							Capacitance change				Within ±20% of the initial capacitance value
								tan δ				200% or less than the initial specified value
Shelf Life	After storing the capacitors under no load at 85°C for 1000 hours and then performing voltage treatment based on JIS C 5101-4 clause 4.1 at 20°C, they shall meet the specified values for the endurance characteristics listed above.											
	Leakage current											Less than or equal to the initial specified value
Marking	Black print on the case top.											

※ I : Leakage Current (μA), C : Rated Capacitance (μF), V : Rated Voltage (V)

Chip Type

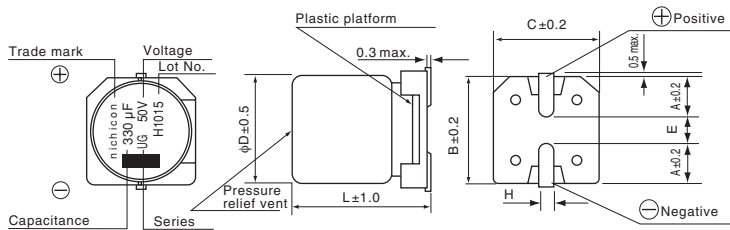

	(mm)						
φD	12.5×13.5	12.5×16	12.5×21	16×16.5	16×21.5	18×16.5	18×21.5
A	5.15	5.15	5.15	5.65	5.65	6.65	6.65
B	13.6	13.6	13.6	17.1	17.1	19.1	19.1
C	13.6	13.6	13.6	17.1	17.1	19.1	19.1
E	(3.3)	(3.3)	(3.3)	(5.8)	(5.8)	(5.8)	(5.8)
L	13.5	16.0	21.0	16.5	21.5	16.5	21.5
H	1.0 to 1.4	1.0 to 1.4	1.0 to 1.4	1.0 to 1.4	1.0 to 1.4	1.0 to 1.4	1.0 to 1.4

Please contact us for the dimensions for NQ.

Type numbering system (Example : 50V 330μF)

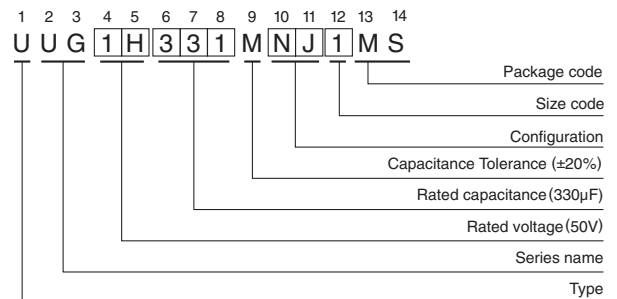

Code	Remarks
NJ	Standard Style
NQ	Products which are scheduled to be discontinued. Not recommended for new designs.

※ There are also some products that can be manufactured as vibration resistant products.

Frequency coefficient of rated ripple current

V	Frequency					
	Cap.(μF)	50Hz	120Hz	300Hz	1kHz	10kHz or more
6.3 to 100	68	0.75	1.00	1.35	1.57	2.00
	100 to 470	0.80	1.00	1.23	1.34	1.50
	1000 to 10000	0.85	1.00	1.10	1.13	1.15
160 to 450	4.7 to 100	0.80	1.00	1.25	1.40	1.60

● Dimension table in next page.

UUG

■ Dimensions

Rated Voltage (V) (code)	Rated Capacitance (μF)	Case Size φD×L (mm)	tan δ	Leakage Current (μA) (at 20°C after 1 minute)	Rated Ripple (mArms) (85°C/120Hz)	Part Number
6.3 (0J)	2200	12.5×16	0.30	415.8	890	UUG0J222M NJ1MS
	3300	16×16.5	0.32	623.7	1200	UUG0J332M NJ1MS
	3300	12.5×21	0.32	623.7	1200	UUG0J332M NJ6MS
	4700	16×16.5	0.34	888.3	1400	UUG0J472M NJ1MS
	6800	18×16.5	0.38	1285.2	1650	UUG0J682M NJ1MS
	6800	16×21.5	0.38	1285.2	1650	UUG0J682M NJ6MS
	10000	18×21.5	0.46	1890	2000	UUG0J103M NJ1MS
10 (1A)	1000	12.5×13.5	0.24	300	620	UUG1A102M NJ1MS
	2200	12.5×16	0.26	660	960	UUG1A222M NJ1MS
	3300	16×16.5	0.28	990	1300	UUG1A332M NJ1MS
	4700	18×16.5	0.30	1410	1500	UUG1A472M NJ1MS
	4700	16×21.5	0.30	1410	1500	UUG1A472M NJ6MS
	6800	18×21.5	0.34	2040	1850	UUG1A682M NJ1MS
	10000	18×21.5	0.42	3000	2200	UUG1A103M NJ6MS
16 (1C)	1000	12.5×13.5	0.20	480	710	UUG1C102M NJ1MS
	2200	16×16.5	0.22	1056	1150	UUG1C222M NJ1MS
	2200	12.5×21	0.22	1056	1150	UUG1C222M NJ6MS
	3300	18×16.5	0.24	1584	1450	UUG1C332M NJ1MS
	3300	16×21.5	0.24	1584	1450	UUG1C332M NJ6MS
	4700	18×21.5	0.26	2256	1750	UUG1C472M NJ1MS
25 (1E)	470	12.5×13.5	0.16	352.5	550	UUG1E471M NJ1MS
	1000	12.5×16	0.16	750	820	UUG1E102M NJ1MS
	2200	18×16.5	0.18	1650	1350	UUG1E222M NJ1MS
	2200	16×21.5	0.18	1650	1350	UUG1E222M NJ6MS
	3300	18×21.5	0.20	2475	1700	UUG1E332M NJ1MS
35 (1V)	470	12.5×13.5	0.14	493.5	580	UUG1V471M NJ1MS
	1000	16×16.5	0.14	1050	1000	UUG1V102M NJ1MS
	1000	12.5×21	0.14	1050	1000	UUG1V102M NJ6MS
	2200	18×21.5	0.16	2310	1550	UUG1V222M NJ1MS
50 (1H)	220	12.5×13.5	0.12	330	450	UUG1H221M NJ1MS
	330	12.5×13.5	0.12	495	520	UUG1H331M NJ1MS
	470	16×16.5	0.12	705	740	UUG1H471M NJ1MS
	470	12.5×21	0.12	705	740	UUG1H471M NJ6MS
	1000	18×21.5	0.12	1500	1150	UUG1H102M NJ1MS
63 (1J)	100	12.5×13.5	0.10	189	370	UUG1J101M NJ1MS
	220	12.5×16	0.10	415.8	580	UUG1J221M NJ1MS
	330	16×16.5	0.10	623.7	680	UUG1J331M NJ1MS
	330	12.5×21	0.10	623.7	680	UUG1J331M NJ6MS
	470	18×16.5	0.10	888.3	850	UUG1J471M NJ1MS
	470	16×21.5	0.10	888.3	850	UUG1J471M NJ6MS
100 (2A)	68	12.5×13.5	0.08	204	350	UUG2A680M NJ1MS
	100	12.5×16	0.08	300	440	UUG2A101M NJ1MS
	220	18×16.5	0.08	660	665	UUG2A221M NJ1MS
	220	16×21.5	0.08	660	665	UUG2A221M NJ6MS
	330	18×21.5	0.08	990	825	UUG2A331M NJ1MS

UUG

■ Dimensions

Rated Voltage (V) (code)	Rated Capacitance (μF)	Case Size φD×L (mm)	tan δ	Leakage Current (μA) (at 20°C after 1 minute)	Rated Ripple (mArms) (85°C/120Hz)	Part Number
160 (2C)	47	12.5×16	0.20	400.8	370	UUG2C470MNJ1MS
	68	16×16.5	0.20	535.2	500	UUG2C680MNJ1MS
	68	12.5×21	0.20	535.2	500	UUG2C680MNJ6MS
	100	18×16.5	0.20	740	590	UUG2C101MNJ1MS
	100	16×21.5	0.20	740	590	UUG2C101MNJ6MS
200 (2D)	22	12.5×13.5	0.20	276	235	UUG2D220MNJ1MS
	33	12.5×16	0.20	364	310	UUG2D330MNJ1MS
	47	16×16.5	0.20	476	415	UUG2D470MNJ1MS
	47	12.5×21	0.20	476	415	UUG2D470MNJ6MS
	68	18×16.5	0.20	644	505	UUG2D680MNJ1MS
	68	16×21.5	0.20	644	505	UUG2D680MNJ6MS
	100	18×21.5	0.20	900	590	UUG2D101MNJ1MS
250 (2E)	10	12.5×13.5	0.20	200	150	UUG2E100MNJ1MS
	22	12.5×16	0.20	320	240	UUG2E220MNJ1MS
	33	16×16.5	0.20	430	340	UUG2E330MNJ1MS
	33	12.5×21	0.20	430	340	UUG2E330MNJ6MS
	47	18×16.5	0.20	570	415	UUG2E470MNJ1MS
	47	16×21.5	0.20	570	415	UUG2E470MNJ6MS
	68	18×21.5	0.20	780	490	UUG2E680MNJ1MS
400 (2G)	4.7	12.5×13.5	0.25	175.2	115	UUG2G470MNJ1MS
	10	16×16.5	0.25	260	140	UUG2G100MNJ1MS
	10	12.5×21	0.25	260	140	UUG2G100MNJ6MS
	22	18×16.5	0.25	452	280	UUG2G220MNJ1MS
	22	16×21.5	0.25	452	280	UUG2G220MNJ6MS
	33	18×21.5	0.25	628	350	UUG2G330MNJ1MS
	47	18×21.5	0.25	852	430	UUG2G470MNJ6MS
450 (2W)	4.7	12.5×13.5	0.25	184.6	115	UUG2W470MNJ1MS
	10	16×16.5	0.25	280	140	UUG2W100MNJ1MS
	10	12.5×21	0.25	280	140	UUG2W100MNJ6MS
	22	16×21.5	0.25	496	275	UUG2W220MNJ1MS
	33	18×21.5	0.25	694	345	UUG2W330MNJ1MS

- For taping specifications, recommended land size/soldering by reflow and minimum order quantity, please refer to the Guidelines for Aluminum Electrolytic Capacitors.

ALUMINUM ELECTROLYTIC CAPACITORS

UUJ

Chip Type, Higher Capacitance Range



For SMD

Long Life

Anti-Solvent
Feature
(Through
100V only)

- Chip Type, higher capacitance in larger case sizes ($\phi 12.5$, $\phi 16$, $\phi 18$)
- Designed for surface mounting on high density PC board.
- Applicable to automatic mounting machine fed with carrier tape.
- Compliant to the RoHS directive (2011/65/EU, (EU)2015/863).
- AEC-Q200 compliant. Please contact us for details.



Valued marked with an ※ in the dimension table are scheduled to be discontinued and are not recommended for new designs.

Specifications

Item	Performance Characteristics											
Category Temperature Range	-55 to +105°C (6.3 to 100V), -40 to +105°C (160 to 450V)											
Rated Voltage Range	6.3 to 450V											
Rated Capacitance Range	3.3 to 6800 μ F											
Capacitance Tolerance	$\pm 20\%$ at 120Hz, 20°C											
Leakage Current ※	Rated voltage (V)	6.3 to 100							160 to 450			
	—	After 1 minute's application of rated voltage at 20°C, leakage current is not more than 0.03CV or 4 (μ A), whichever is greater.							I = 0.04CV+100 (μ A) max. (1 minute's at 20°C)			
Tangent of loss angle (tan δ)	Measurement frequency : 120Hz at 20°C											
	Rated voltage (V)	6.3	10	16	25	35	50	63	100	160 to 250	400 - 450	
	tan δ (max.)	0.26	0.22	0.18	0.16	0.14	0.12	0.10	0.08	0.15	0.20	
For capacitance of more than 1000 μ F, add 0.02 for every increase of 1000 μ F. ($\phi 12.5$ to $\phi 18$)												
Stability at Low Temperature	Measurement frequency: 120Hz											
	Rated voltage (V)	6.3	10	16	25	35	50	63	100	160 to 250	400 - 450	
	Impedance ratio (max.)	Z(-25°C) / Z(+20°C)	5	4	3	2	2	2	2	2	3	6
Endurance	The specifications listed at right shall be met when the capacitors are restored to 20°C after the rated voltage is applied for 5000 hours at 105°C.											
	Capacitance change	Within $\pm 20\%$ of the initial capacitance value										
	tan δ	200% or less than the initial specified value										
Shelf Life	After storing the capacitors under no load at 105°C for 1000 hours and then performing voltage treatment based on JIS C 5101-4 clause 4.1 at 20°C, they shall meet the specified values for the endurance characteristics listed above.											
	Leakage current											
Marking	Black print on the case top.											

※ I : Leakage Current (μ A), C : Rated Capacitance (μ F), V : Rated Voltage (V)

Chip Type

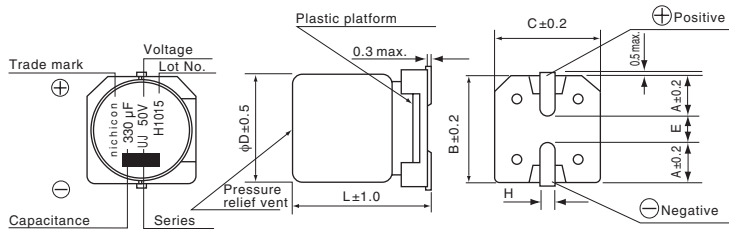

Type numbering system (Example : 50V 330 μ F)

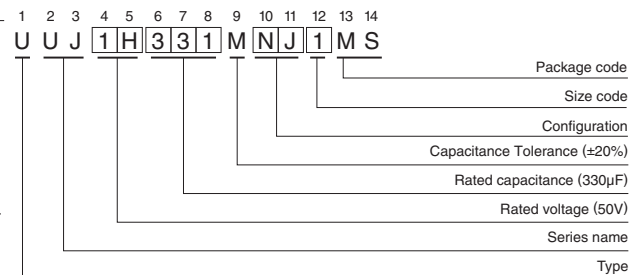

ϕ D	12.5x13.5	12.5x16	12.5x21	16x16.5	16x21.5	18x16.5	18x21.5
A	5.15	5.15	5.15	5.65	5.65	6.65	6.65
B	13.6	13.6	13.6	17.1	17.1	19.1	19.1
C	13.6	13.6	13.6	17.1	17.1	19.1	19.1
E	(3.3)	(3.3)	(3.3)	(5.8)	(5.8)	(5.8)	(5.8)
L	13.5	16.0	21.0	16.5	21.5	16.5	21.5
H	1.0 to 1.4	1.0 to 1.4	1.0 to 1.4	1.0 to 1.4	1.0 to 1.4	1.0 to 1.4	1.0 to 1.4

Please contact us for the dimensions for NQ.

Code	Remarks
NJ	Standard Style
NQ	Products which are scheduled to be discontinued. Not recommended for new designs.

※ There are also some products that can be manufactured as vibration resistant products.

Frequency coefficient of rated ripple current

V	Cap. (μ F)	Frequency				
		50Hz	120Hz	300Hz	1kHz	10kHz or more
6.3 to 100	47 to 68	0.75	1.00	1.35	1.57	2.00
	100 to 470	0.80	1.00	1.23	1.34	1.50
	1000 to 6800	0.85	1.00	1.10	1.13	1.15
160 to 450	3.3 to 100	0.80	1.00	1.25	1.40	1.60

• Dimension table in next page.

UUJ

■ Dimensions

Rated Voltage (V) (code)	Rated Capacitance (μF)	Case Size φD×L (mm)	tan δ	Leakage Current (μA) (at 20°C after 1 minute)	Rated Ripple (mArms) (105°C/120Hz)	Part Number
6.3 (0J)	1000	12.5×13.5	0.26	189	440	※UUJ0J102MNQ1MS
	2200	16×16.5	0.28	415.8	750	※UUJ0J222MNQ1MS
	2200	12.5×21	0.28	415.8	750	※UUJ0J222MNQ6MS
	3300	18×16.5	0.30	623.7	930	※UUJ0J332MNQ1MS
	3300	16×21.5	0.30	623.7	930	※UUJ0J332MNQ6MS
	4700	18×21.5	0.32	888.3	1100	※UUJ0J472MNQ1MS
	6800	18×21.5	0.36	1285.2	1350	※UUJ0J682MNQ6MS
10 (1A)	1000	12.5×16	0.22	300	500	UUJ1A102MNJ1MS
	2200	16×16.5	0.24	660	810	UUJ1A222MNJ1MS
	2200	12.5×21	0.24	660	810	UUJ1A222MNJ6MS
	3300	18×16.5	0.26	990	1000	UUJ1A332MNJ1MS
	3300	16×21.5	0.26	990	1000	UUJ1A332MNJ6MS
	4700	18×21.5	0.28	1410	1200	UUJ1A472MNJ1MS
	6800	18×21.5	0.32	2040	1450	UUJ1A682MNJ6MS
16 (1C)	470	12.5×13.5	0.18	225.6	360	UUJ1C471MNJ1MS
	1000	16×16.5	0.18	480	630	UUJ1C102MNJ1MS
	1000	12.5×21	0.18	480	630	UUJ1C102MNJ6MS
	2200	18×16.5	0.20	1056	930	UUJ1C222MNJ1MS
	2200	16×21.5	0.20	1056	930	UUJ1C222MNJ6MS
	3300	18×21.5	0.22	1584	1150	UUJ1C332MNJ1MS
	25 (1E)	330	12.5×13.5	0.16	247.5	320
470		12.5×16	0.16	352.5	400	UUJ1E471MNJ1MS
1000		18×16.5	0.16	750	700	UUJ1E102MNJ1MS
1000		16×21.5	0.16	750	700	UUJ1E102MNJ6MS
2200		18×21.5	0.18	1650	1050	UUJ1E222MNJ1MS
35 (1V)		220	12.5×13.5	0.14	231	280
	330	12.5×16	0.14	346.5	360	UUJ1V331MNJ1MS
	470	16×16.5	0.14	493.5	490	UUJ1V471MNJ1MS
	470	12.5×21	0.14	493.5	490	UUJ1V471MNJ6MS
	1000	18×16.5	0.14	1050	750	UUJ1V102MNJ1MS
	1000	16×21.5	0.14	1050	750	UUJ1V102MNJ6MS
	2200	18×21.5	0.16	2310	1150	UUJ1V222MNJ6MS
	50 (1H)	220	12.5×16	0.12	330	320
330		16×16.5	0.12	495	440	UUJ1H331MNJ1MS
330		12.5×21	0.12	495	440	UUJ1H331MNJ6MS
470		18×16.5	0.12	705	550	UUJ1H471MNJ1MS
470		16×21.5	0.12	705	550	UUJ1H471MNJ6MS
1000		18×21.5	0.12	1500	820	UUJ1H102MNJ1MS
63 (1J)		68	12.5×13.5	0.10	128.52	175
	100	12.5×16	0.10	189	225	UUJ1J101MNJ1MS
	220	16×16.5	0.10	415.8	385	UUJ1J221MNJ1MS
	220	12.5×21	0.10	415.8	385	UUJ1J221MNJ6MS
	330	18×16.5	0.10	623.7	490	UUJ1J331MNJ1MS
	330	16×21.5	0.10	623.7	490	UUJ1J331MNJ6MS
	470	18×21.5	0.10	888.3	590	UUJ1J471MNJ1MS



■ Dimensions

Rated Voltage (V) (code)	Rated Capacitance (μF)	Case Size φD×L (mm)	tan δ	Leakage Current (μA) (at 20°C after 1 minute)	Rated Ripple (mArms) (105°C/120Hz)	Part Number
100 (2A)	47	12.5×13.5	0.08	141	160	UUJ2A470MNNJ1MS
	68	12.5×16	0.08	204	205	UUJ2A680MNNJ1MS
	100	16×16.5	0.08	300	285	UUJ2A101MNNJ1MS
	100	12.5×21	0.08	300	285	UUJ2A101MNNJ6MS
	220	18×16.5	0.08	660	440	UUJ2A221MNNJ1MS
	220	16×21.5	0.08	660	440	UUJ2A221MNNJ6MS
	330	18×21.5	0.08	990	500	UUJ2A331MNNJ6MS
160 (2C)	33	12.5×13.5	0.15	311.2	95	UUJ2C330MNNJ1MS
	47	16×16.5	0.15	400.8	260	UUJ2C470MNNJ1MS
	47	12.5×21	0.15	400.8	260	UUJ2C470MNNJ6MS
	68	18×16.5	0.15	535.2	320	UUJ2C680MNNJ1MS
	68	16×21.5	0.15	535.2	320	UUJ2C680MNNJ6MS
	100	16×21.5	0.15	740	380	UUJ2C101MNNJ1MS
200 (2D)	10	12.5×13.5	0.15	180	80	UUJ2D100MNNJ1MS
	22	12.5×16	0.15	276	105	UUJ2D220MNNJ1MS
	33	16×16.5	0.15	364	220	UUJ2D330MNNJ1MS
	33	12.5×21	0.15	364	220	UUJ2D330MNNJ6MS
	47	18×16.5	0.15	476	270	UUJ2D470MNNJ1MS
	47	16×21.5	0.15	476	270	UUJ2D470MNNJ6MS
	68	18×21.5	0.15	644	330	UUJ2D680MNNJ1MS
	100	18×21.5	0.15	900	410	UUJ2D101MNNJ6MS
250 (2E)	4.7	12.5×13.5	0.15	147	65	UUJ2E4R7MNNJ1MS
	10	12.5×16	0.15	200	105	UUJ2E100MNNJ1MS
	22	16×16.5	0.15	320	180	UUJ2E220MNNJ1MS
	22	12.5×21	0.15	320	180	UUJ2E220MNNJ6MS
	33	18×16.5	0.15	430	230	UUJ2E330MNNJ1MS
	33	16×21.5	0.15	430	230	UUJ2E330MNNJ6MS
	47	18×21.5	0.15	570	280	UUJ2E470MNNJ1MS
	68	18×21.5	0.15	780	340	UUJ2E680MNNJ6MS
400 (2G)	4.7	12.5×16	0.20	175.2	50	UUJ2G4R7MNNJ1MS
	10	16×16.5	0.20	260	85	UUJ2G100MNNJ1MS
	22	18×21.5	0.20	452	130	UUJ2G220MNNJ1MS
	33	18×21.5	0.20	628	160	UUJ2G330MNNJ6MS
450 (2W)	3.3	12.5×13.5	0.20	159.4	40	UUJ2W3R3MNNJ1MS
	4.7	12.5×16	0.20	184.6	50	UUJ2W4R7MNNJ1MS
	10	16×16.5	0.20	280	85	UUJ2W100MNNJ1MS
	22	18×21.5	0.20	496	130	UUJ2W220MNNJ1MS
	33	18×21.5	0.20	694	160	UUJ2W330MNNJ6MS

• For taping specifications, recommended land size/soldering by reflow and minimum order quantity, please refer to the Guidelines for Aluminum Electrolytic Capacitors.

ALUMINUM ELECTROLYTIC CAPACITORS

UUN Chip Type, Bi-Polarized,
Higher Capacitance Range



- Chip Type, higher capacitance in larger case sizes (φ12.5, φ16, φ18)
- Designed for surface mounting on high density PC board.
- Bi-polarized series for operations over wide temperature range of -55 to +105°C.
- Applicable to automatic mounting machine fed with carrier tape.
- Compliant to the RoHS directive (2011/65/EU, (EU)2015/863).



Specifications

Item	Performance Characteristics																												
Category Temperature Range	-55 to +105°C																												
Rated Voltage Range	6.3 to 100V																												
Rated Capacitance Range	22 to 3300μF																												
Capacitance Tolerance	±20% at 120Hz, 20°C																												
Leakage Current ※	After 1 minute's application of rated voltage at 20°C, leakage current is not more than 0.03CV or 4 (μA), whichever is greater.																												
Tangent of loss angle (tan δ)	Measurement frequency : 120Hz at 20°C																												
	<table border="1"> <tr> <td>Rated voltage (V)</td> <td>6.3</td> <td>10</td> <td>16</td> <td>25</td> <td>35</td> <td>50</td> <td>63</td> <td>100</td> </tr> <tr> <td>tan δ (max.)</td> <td>0.26</td> <td>0.22</td> <td>0.18</td> <td>0.16</td> <td>0.14</td> <td>0.12</td> <td>0.10</td> <td>0.09</td> </tr> </table> <p>For capacitance of more than 1000μF, add 0.02 for every increase of 1000μF.</p>	Rated voltage (V)	6.3	10	16	25	35	50	63	100	tan δ (max.)	0.26	0.22	0.18	0.16	0.14	0.12	0.10	0.09										
Rated voltage (V)	6.3	10	16	25	35	50	63	100																					
tan δ (max.)	0.26	0.22	0.18	0.16	0.14	0.12	0.10	0.09																					
Stability at Low Temperature	Measurement frequency: 120Hz																												
	<table border="1"> <tr> <td colspan="2">Rated voltage (V)</td> <td>6.3</td> <td>10</td> <td>16</td> <td>25</td> <td>35</td> <td>50</td> <td>63</td> <td>100</td> </tr> <tr> <td rowspan="2">Impedance ratio (max.)</td> <td>Z(-25°C) / Z(+20°C)</td> <td>5</td> <td>4</td> <td>3</td> <td>2</td> <td>2</td> <td>2</td> <td>2</td> <td>2</td> </tr> <tr> <td>Z(-40°C) / Z(+20°C)</td> <td>10</td> <td>8</td> <td>6</td> <td>4</td> <td>3</td> <td>3</td> <td>3</td> <td>3</td> </tr> </table>	Rated voltage (V)		6.3	10	16	25	35	50	63	100	Impedance ratio (max.)	Z(-25°C) / Z(+20°C)	5	4	3	2	2	2	2	2	Z(-40°C) / Z(+20°C)	10	8	6	4	3	3	3
Rated voltage (V)		6.3	10	16	25	35	50	63	100																				
Impedance ratio (max.)	Z(-25°C) / Z(+20°C)	5	4	3	2	2	2	2	2																				
	Z(-40°C) / Z(+20°C)	10	8	6	4	3	3	3	3																				
Endurance	<p>The specifications listed at right shall be met when the capacitors are restored to 20°C after the rated voltage is applied for 2000 hours at 105°C with the polarity inverted every 250 hours.</p> <table border="1"> <tr> <td>Capacitance change</td> <td>Within ±20% of the initial capacitance value</td> </tr> <tr> <td>tan δ</td> <td>200% or less than the initial specified value</td> </tr> <tr> <td>Leakage current</td> <td>Less than or equal to the initial specified value</td> </tr> </table>	Capacitance change	Within ±20% of the initial capacitance value	tan δ	200% or less than the initial specified value	Leakage current	Less than or equal to the initial specified value																						
Capacitance change	Within ±20% of the initial capacitance value																												
tan δ	200% or less than the initial specified value																												
Leakage current	Less than or equal to the initial specified value																												
Shelf Life	After storing the capacitors under no load at 105°C for 1000 hours and then performing voltage treatment based on JIS C 5101-4 clause 4.1 at 20°C, they shall meet the specified values for the endurance characteristics listed above.																												
Marking	Black print on the case top.																												

※ I : Leakage Current (μA), C : Rated Capacitance (μF), V : Rated Voltage (V)

Chip Type

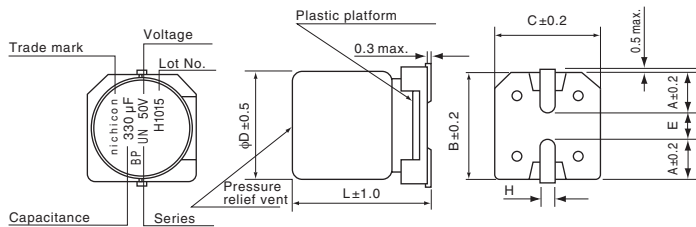

Type numbering system (Example : 50V 330μF)

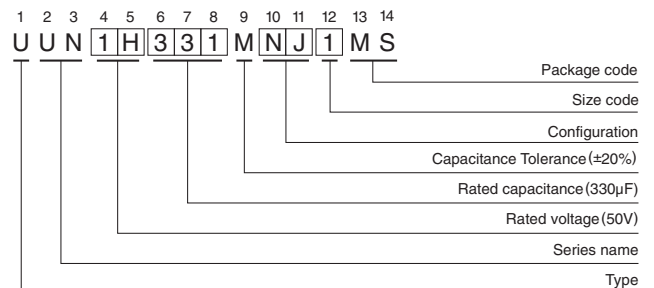

	(mm)					
φD	12.5×13.5	12.5×16	16×16.5	16×21.5	18×16.5	18×21.5
A	5.15	5.15	5.65	5.65	6.65	6.65
B	13.6	13.6	17.1	17.1	19.1	19.1
C	13.6	13.6	17.1	17.1	19.1	19.1
E	(3.3)	(3.3)	(5.8)	(5.8)	(5.8)	(5.8)
L	13.5	16.0	16.5	21.5	16.5	21.5
H	1.0 to 1.4	1.0 to 1.4	1.0 to 1.4	1.0 to 1.4	1.0 to 1.4	1.0 to 1.4

Please contact us for the dimensions for NQ.

Code	Remarks
NJ	Standard Style
NQ	Products which are scheduled to be discontinued. Not recommended for new designs.

※ There are also some products that can be manufactured as vibration resistant products.

Frequency coefficient of rated ripple current

Cap.(μF)	Frequency	50 Hz	120 Hz	300 Hz	1 kHz	10 kHz or more
22 to 47		0.75	1.00	1.35	1.57	2.00
100 to 470		0.80	1.00	1.23	1.34	1.50
1000 to 3300		0.85	1.00	1.10	1.13	1.15

● Dimension table in next page.

UUN

■ Dimensions

Rated Voltage (V) (code)	Rated Capacitance (μF)	Case Size φD×L (mm)	tan δ	Leakage Current (μA) (at 20°C after 1 minute)	Rated Ripple (mArms) (105°C/120Hz)	Part Number
6.3 (0J)	470	12.5×13.5	0.26	88.83	270	UUN0J471MNJ1MS
	1000	12.5×16	0.26	189	500	UUN0J102MNJ1MS
	2200	18×16.5	0.28	415.8	740	UUN0J222MNJ1MS
	2200	16×21.5	0.28	415.8	740	UUN0J222MNJ6MS
	3300	18×21.5	0.30	623.7	920	UUN0J332MNJ1MS
10 (1A)	470	12.5×13.5	0.22	141	340	UUN1A471MNJ1MS
	1000	16×16.5	0.22	300	600	UUN1A102MNJ1MS
	2200	18×21.5	0.24	660	830	UUN1A222MNJ1MS
16 (1C)	330	12.5×13.5	0.18	158.4	310	UUN1C331MNJ1MS
	470	16×16.5	0.18	225.6	420	UUN1C471MNJ1MS
	1000	18×16.5	0.18	480	670	UUN1C102MNJ1MS
	1000	16×21.5	0.18	480	670	UUN1C102MNJ6MS
25 (1E)	220	12.5×13.5	0.16	165	270	UUN1E221MNJ1MS
	330	16×16.5	0.16	247.5	370	UUN1E331MNJ1MS
	470	16×16.5	0.16	352.5	490	UUN1E471MNJ1MS
	1000	18×21.5	0.16	750	780	UUN1E102MNJ1MS
35 (1V)	100	12.5×13.5	0.14	105	180	UUN1V101MNJ1MS
	220	16×16.5	0.14	231	330	UUN1V221MNJ1MS
	330	18×16.5	0.14	346.5	450	UUN1V331MNJ1MS
	330	16×21.5	0.14	346.5	450	UUN1V331MNJ6MS
	470	18×21.5	0.14	493.5	590	UUN1V471MNJ1MS
50 (1H)	47	12.5×13.5	0.12	70.5	130	UUN1H470MNJ1MS
	100	12.5×16	0.12	150	230	UUN1H101MNJ1MS
	220	18×16.5	0.12	330	400	UUN1H221MNJ1MS
	220	16×21.5	0.12	330	400	UUN1H221MNJ6MS
	330	18×21.5	0.12	495	540	UUN1H331MNJ1MS
	470	18×21.5	0.12	705	640	UUN1H471MNJ6MS
63 (1J)	47	12.5×13.5	0.10	88.83	140	UUN1J470MNJ1MS
	100	16×16.5	0.10	189	270	UUN1J101MNJ1MS
	220	18×21.5	0.10	415.8	440	UUN1J221MNJ1MS
	330	18×21.5	0.10	623.7	590	UUN1J331MNJ6MS
100 (2A)	22	12.5×13.5	0.09	66	100	UUN2A220MNJ1MS
	33	12.5×16	0.09	99	150	UUN2A330MNJ1MS
	47	16×16.5	0.09	141	180	UUN2A470MNJ1MS
	100	18×21.5	0.09	300	310	UUN2A101MNJ1MS

• For taping specifications, recommended land size/soldering by reflow and minimum order quantity, please refer to the Guidelines for Aluminum Electrolytic Capacitors.

ALUMINUM ELECTROLYTIC CAPACITORS

UUE

Chip Type, Vibration Resistance



- Chip type with load life of 2000 to 5000 hours at 125°C.
- Suited for automobile electronics where heavy duty services are indispensable.
- Compliant to the RoHS directive (2011/65/EU,(EU)2015/863).
- AEC-Q200 compliant. Please contact us for details.

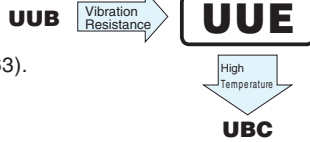

■ Specifications

Item	Performance Characteristics												
Category Temperature Range	-40 to +125°C (φ8, φ10), -55 to +125°C (φ12.5 to 18)												
Rated Voltage Range	10 to 50V												
Rated Capacitance Range	33 to 4700μF												
Capacitance Tolerance	±20% at 120Hz, 20°C												
Leakage Current ※	After 1 minute's application of rated voltage at 20°C, leakage current is not more than 0.03CV or 4 (μA), whichever is greater.												
Tangent of loss angle (tan δ)	For capacitance of more than 1000μF, add 0.02 for every increase of 1000μF. (φ12.5 to φ18)												
	Rated voltage (V)	10	16	25	35	50	120Hz						
	tan δ (max.)	φ8, φ10	0.26	0.20	0.16	0.14	0.14	20°C					
Stability at Low Temperature	Rated voltage (V)	10	16	25	35	50	120Hz						
	Impedance ratio Z(-40°C) / Z(+20°C) (max.)	φ8, φ10	10	8	6	4	4						
		φ12.5 to φ18	8	6	4	3	3						
Endurance	The specifications listed at right shall be met when the capacitors are restored to 20°C after the rated voltage is applied for 5000 hours (2000 hours for φD=8 and 10) at 125°C.						<table border="1"> <tr> <td>Capacitance change</td> <td>Within ±30% of the initial capacitance value</td> </tr> <tr> <td>tan δ</td> <td>300% or less than the initial specified value</td> </tr> <tr> <td>Leakage current</td> <td>Less than or equal to the initial specified value</td> </tr> </table>	Capacitance change	Within ±30% of the initial capacitance value	tan δ	300% or less than the initial specified value	Leakage current	Less than or equal to the initial specified value
Capacitance change	Within ±30% of the initial capacitance value												
tan δ	300% or less than the initial specified value												
Leakage current	Less than or equal to the initial specified value												
Shelf Life	After storing the capacitors under no load at 125°C for 1000 hours and then performing voltage treatment based on JIS C 5101-4 clause 4.1 at 20°C, they shall meet the specified values for the endurance characteristics listed above.												
Marking	Black print on the case top.												

※ I : Leakage Current (μA), C : Rated Capacitance (μF), V : Rated Voltage (V)

■ Chip Type

(φ8, φ10) [Vibration Resistance]

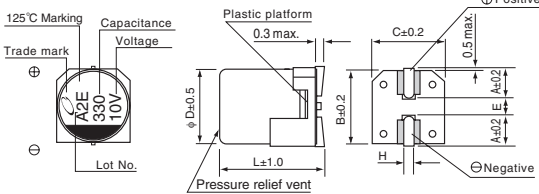

※ φ8 to φ10 The standard structure product is also available upon request, please refer to UUB.

(φ12.5 to φ18) [Vibration Resistance]

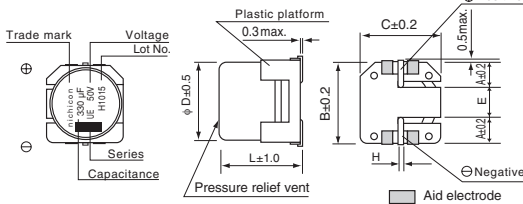

※ φ12.5 to φ18 The standard structure product is also available upon request, please ask for details.

Type numbering system (Example : 50V 330μF)

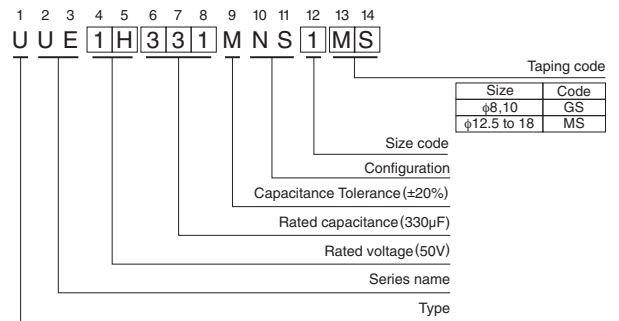

φD	8	10	12.5	16	18
A	2.9	3.2	4.8	5.4	6.4
B	8.3	10.3	13.6	17.1	19.1
C	8.3	10.3	13.6	17.1	19.1
E	3.1	4.5	(4.0)	(6.3)	(6.3)
L	10	10	13.5,16	16.5,21.5	16.5,21.5
H	1.1 to 1.5	1.1 to 1.5	1.0 to 1.4	1.0 to 1.4	1.0 to 1.4

● Frequency coefficient of rated ripple current

φD	C ₃₀ (μF)	Frequency				
		50 Hz	120 Hz	300 Hz	1 kHz	10 kHz or more
φ8, φ10	33 to 330	0.47	0.67	0.78	0.91	1.00
φ12.5 to φ18	100 to 680	0.53	0.67	0.82	0.89	1.00
	1000 to 4700	0.74	0.87	0.96	0.98	1.00

● Dimension table in next page.

UUE

■ Dimensions

Rated Voltage (V) (code)	Rated Capacitance (μF)	Case Size φD×L (mm)	tan δ	Leakage Current (μA) (at 20°C after 1 minute)	Rated Ripple (mArms) (125°C/100kHz)	Part Number
10 (1A)	220	8×10	0.26	66	140	UUE1A221MNS1GS
	330	10×10	0.26	99	190	UUE1A331MNS1GS
	470	12.5×13.5	0.22	141	750	UUE1A471MNS1MS
	680	12.5×16	0.22	204	900	UUE1A681MNS1MS
	1000	12.5×16	0.22	300	900	UUE1A102MNS1MS
	2200	18×16.5	0.24	660	1200	UUE1A222MNS1MS
	2200	16×21.5	0.24	660	1200	UUE1A222MNS6MS
	3300	18×16.5	0.26	990	1200	UUE1A332MNS1MS
4700	18×21.5	0.28	1410	1550	UUE1A472MNS1MS	
16 (1C)	100	8×10	0.20	48	140	UUE1C101MNS1GS
	220	10×10	0.20	105.6	190	UUE1C221MNS1GS
	330	12.5×13.5	0.18	158.4	750	UUE1C331MNS1MS
	470	12.5×13.5	0.18	225.6	750	UUE1C471MNS1MS
	680	16×16.5	0.18	326.4	1000	UUE1C681MNS1MS
	1000	18×16.5	0.18	480	1200	UUE1C102MNS1MS
	2200	18×16.5	0.20	1056	1200	UUE1C222MNS1MS
25 (1E)	100	8×10	0.16	75	140	UUE1E101MNS1GS
	220	10×10	0.16	165	190	UUE1E221MNS1GS
	330	12.5×13.5	0.16	247.5	750	UUE1E331MNS1MS
	470	16×16.5	0.16	352.5	1000	UUE1E471MNS1MS
	680	18×16.5	0.16	510	1200	UUE1E681MNS1MS
	680	16×21.5	0.16	510	1200	UUE1E681MNS6MS
	1000	18×21.5	0.16	750	1550	UUE1E102MNS1MS
35 (1V)	47	8×10	0.14	49.35	100	UUE1V470MNS1GS
	100	10×10	0.14	105	150	UUE1V101MNS1GS
	220	12.5×13.5	0.14	231	550	UUE1V221MNS1MS
	330	16×16.5	0.14	346.5	1000	UUE1V331MNS1MS
	470	16×16.5	0.14	493.5	1000	UUE1V471MNS1MS
	680	18×16.5	0.14	714	1200	UUE1V681MNS1MS
	1000	18×21.5	0.14	1050	1400	UUE1V102MNS6MS
50 (1H)	33	8×10	0.14	49.5	90	UUE1H330MNS1GS
	47	10×10	0.14	70.5	130	UUE1H470MNS1GS
	100	12.5×13.5	0.12	150	500	UUE1H101MNS1MS
	220	16×16.5	0.12	330	850	UUE1H221MNS1MS
	330	16×16.5	0.12	495	850	UUE1H331MNS1MS
	470	18×16.5	0.12	705	950	UUE1H471MNS1MS

• For taping specifications, recommended land size/soldering by reflow and minimum order quantity, please refer to the Guidelines for Aluminum Electrolytic Capacitors.

ALUMINUM ELECTROLYTIC CAPACITORS

UBC

Chip Type, High Temperature Range,
Vibration Resistance



For SMD



Long Life



Anti-Solvent Feature



- Highly dependable reliability withstanding load life of 1000 hours at +150°C.
- Suited for automobile electronics where heavy duty services are indispensable.
- Compliant to the RoHS directive (2011/65/EU,(EU)2015/863).
- AEC-Q200 compliant. Please contact us for details.

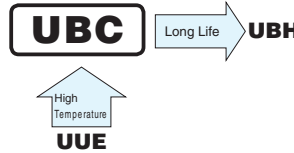

Valued marked with an ※ in the dimension table are scheduled to be discontinued and are not recommended for new designs.

Specifications

Item	Performance Characteristics												
Category Temperature Range	-40 to +150°C (φ8 to 10), -55 to +150°C (φ12.5 to 18)												
Rated Voltage Range	10 to 50V												
Rated Capacitance Range	33 to 3300μF												
Capacitance Tolerance	±20% at 120Hz, 20°C												
Leakage Current ※	After 1 minute's application of rated voltage at 20°C, leakage current is not more than 0.03CV or 4 (μA), whichever is greater.												
Tangent of loss angle (tan δ)	Rated voltage (V)	10	16	25	35	50	120Hz 20°C						
	tan δ (max.)	φ8, φ10	0.26	0.20	0.16	0.14		0.14					
		φ12.5 to φ18	0.22	0.18	0.16	0.14		0.12					
For capacitance of more than 1000μF, add 0.02 for every increase of 1000μF. (φ12.5 to φ18)													
Stability at Low Temperature	Rated voltage (V)	10	16	25	35	50	120Hz						
	Impedance ratio Z(-40°C) / Z(+20°C) (max.)	φ8, φ10	10	8	6	4		4					
		φ12.5 to φ18	8	6	4	4		4					
Endurance	The specifications listed at right shall be met when the capacitors are restored to 20°C after the rated voltage is applied for 1000 hours at 150°C.						<table border="1"> <tr> <td>Capacitance change</td> <td>Within ±30% of the initial capacitance value</td> </tr> <tr> <td>tan δ</td> <td>300% or less than the initial specified value</td> </tr> <tr> <td>Leakage current</td> <td>Less than or equal to the initial specified value</td> </tr> </table>	Capacitance change	Within ±30% of the initial capacitance value	tan δ	300% or less than the initial specified value	Leakage current	Less than or equal to the initial specified value
Capacitance change	Within ±30% of the initial capacitance value												
tan δ	300% or less than the initial specified value												
Leakage current	Less than or equal to the initial specified value												
Shelf Life	After storing the capacitors under no load at 150°C for 1000 hours and then performing voltage treatment based on JIS C 5101-4 clause 4.1 at 20°C, they shall meet the specified values for the endurance characteristics listed above.												
Marking	Black print on the case top.												

※ I : Leakage Current (μA), C : Rated Capacitance (μF), V : Rated Voltage (V)

Chip Type

(φ8, φ10) 【Vibration Resistance】

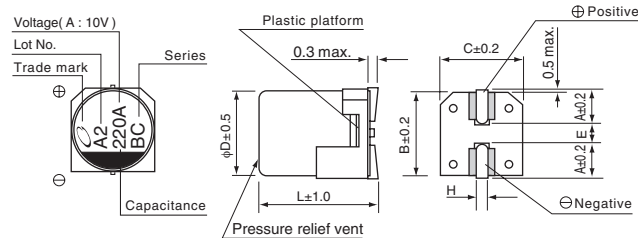

(φ12.5 to φ18) 【Vibration Resistance】

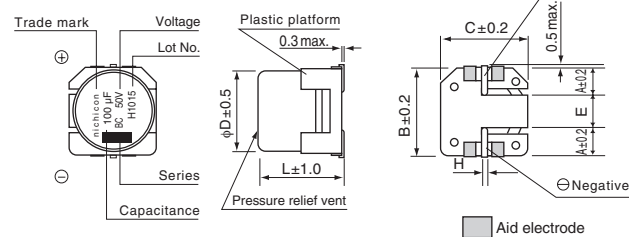

Type numbering system (Example : 10V 220μF)

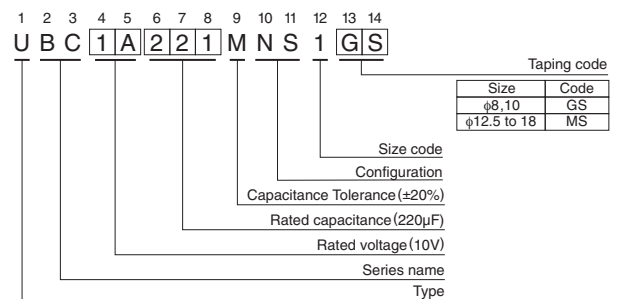

φD	(mm)				
	8	10	12.5	16	18
A	2.9	3.2	4.8	5.4	6.4
B	8.3	10.3	13.6	17.1	19.1
C	8.3	10.3	13.6	17.1	19.1
E	3.1	4.5	(4.0)	(6.3)	(6.3)
L	10	10	13.5	16.5, 21.5	21.5
H	1.1 to 1.5	1.1 to 1.5	1.0 to 1.4	1.0 to 1.4	1.0 to 1.4

Frequency coefficient of rated ripple current

Frequency	120 Hz	300 Hz	1 kHz	10kHz or more
Coefficient	0.67	0.79	0.91	1.00

● Dimension table in next page.

UBC

■ Dimensions

Rated Voltage (V) (code)	Rated Capacitance (μF)	Case Size φD×L (mm)	tan δ	Leakage Current (μA) (at 20°C after 1 minute)	Rated Ripple (mArms) (150°C/100kHz)	Part Number
10 (1A)	220	8×10	0.26	66	110	※UBC1A221MNS1GS
	330	10×10	0.26	99	150	※UBC1A331MNS1GS
	680	12.5×13.5	0.22	204	800	※UBC1A681MNS1MS
	1000	12.5×13.5	0.22	300	900	※UBC1A102MNS1MS
	2200	18×21.5	0.24	660	1350	※UBC1A222MNS1MS
	3300	18×21.5	0.26	990	1400	※UBC1A332MNS1MS
16 (1C)	100	8×10	0.20	48	110	UBC1C101MNS1GS
	220	10×10	0.20	105.6	150	UBC1C221MNS1GS
	470	12.5×13.5	0.18	225.6	750	UBC1C471MNS1MS
	680	12.5×13.5	0.18	326.4	800	UBC1C681MNS1MS
	1000	16×16.5	0.18	480	850	UBC1C102MNS1MS
	2200	18×21.5	0.20	1056	1350	UBC1C222MNS1MS
25 (1E)	100	8×10	0.16	75	110	UBC1E101MNS1GS
	220	10×10	0.16	165	150	UBC1E221MNS1GS
	330	12.5×13.5	0.16	247.5	650	UBC1E331MNS1MS
	470	12.5×13.5	0.16	352.5	700	UBC1E471MNS1MS
	680	16×16.5	0.16	510	800	UBC1E681MNS1MS
	1000	16×21.5	0.16	750	1000	UBC1E102MNS1MS
35 (1V)	47	8×10	0.14	49.35	80	UBC1V470MNS1GS
	100	10×10	0.14	105	120	UBC1V101MNS1GS
	220	12.5×13.5	0.14	231	550	UBC1V221MNS1MS
	330	12.5×13.5	0.14	346.5	650	UBC1V331MNS1MS
	470	16×16.5	0.14	493.5	750	UBC1V471MNS1MS
	680	16×21.5	0.14	714	950	UBC1V681MNS1MS
	1000	18×21.5	0.14	1050	1150	UBC1V102MNS1MS
50 (1H)	33	8×10	0.14	49.5	70	UBC1H330MNS1GS
	47	10×10	0.14	70.5	100	UBC1H470MNS1GS
	100	12.5×13.5	0.12	150	420	UBC1H101MNS1MS
	220	16×16.5	0.12	330	550	UBC1H221MNS1MS
	330	16×21.5	0.12	495	650	UBC1H331MNS1MS
	470	16×21.5	0.12	705	850	UBC1H471MNS1MS
	680	18×21.5	0.12	1020	1100	UBC1H681MNS1MS

- For taping specifications, recommended land size/soldering by reflow and minimum order quantity, please refer to the Guidelines for Aluminum Electrolytic Capacitors.

ALUMINUM ELECTROLYTIC CAPACITORS

UBH

Chip Type, High Temperature Range,
Vibration Resistance
Low temperature ESR specification



- Highly dependable reliability withstanding load life of 1500 to 2000 hours at +150°C, Low temperature ESR.
- Compliant to the RoHS directive (2011/65/EU,(EU)2015/863).
- AEC-Q200 compliant. Please contact us for details.

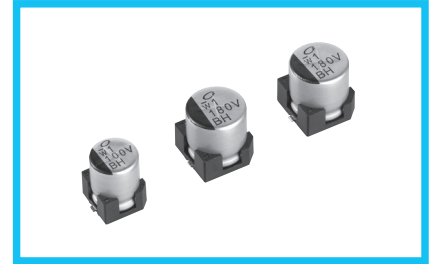

Specifications

Item	Performance Characteristics				
Category Temperature Range	-40 to +150°C				
Rated Voltage Range	25 to 35V				
Rated Capacitance Range	100 to 270μF				
Capacitance Tolerance	±20% at 120Hz, 20°C				
Leakage Current ※	After 2 minute's application of rated voltage at 20°C, leakage current is not more than 0.01CV .				
Tangent of loss angle (tan δ)	Rated voltage (V)	25	35	120Hz at 20°C	
	tan δ (max.)	0.16	0.14		
Stability at Low Temperature	Rated voltage (V)	25	35	120Hz	
	Impedance ratio ZT/Z20 (max.) Z-(40°C)/Z(+20°C)	6	4		
Endurance	The specifications listed at right shall be met when the capacitors are restored to 20°C after the rated voltage is applied for 2000 hours at 150°C (φ 8 = 1500 hours) .			Capacitance change	Within ±40% of the initial capacitance value
				tan δ	400% or less than the initial specified value
				Leakage current	Less than or equal to the initial specified value
Shelf Life	After storing the capacitors under no load at 150°C for 1000 hours and then performing voltage treatment based on JIS C 5101-4 clause 4.1 at 20°C, they shall meet the specified values for the endurance characteristics listed above.				
Resistance to soldering heat	The capacitors are kept on a hot plate for 30 seconds, which is maintained at 250°C. The capacitors shall meet the characteristic requirements listed at right when they are removed from the plate and restored to 20°C.			Capacitance change	Within ±10% of the initial capacitance value
				tan δ	Less than or equal to the initial specified value
				Leakage current	Less than or equal to the initial specified value
Marking	Black print on the case top.				

※ I : Leakage Current (μA), C : Rated Capacitance (μF), V : Rated Voltage (V)

Chip Type

(φ8 , φ10) 【Vibration Resistance】

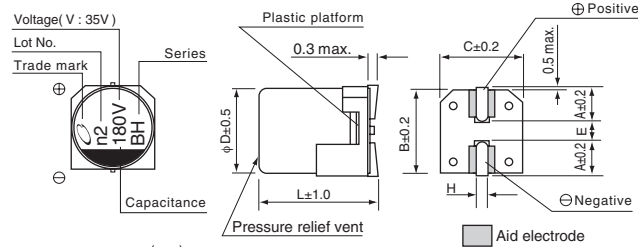

φD×L (mm)	8×10	10×10
A	2.9	3.2
B	8.3	10.3
C	8.3	10.3
E	3.1	4.5
L	10	10
H	1.1 to 1.5	1.1 to 1.5

Type numbering system (Example : 35V 180μF)

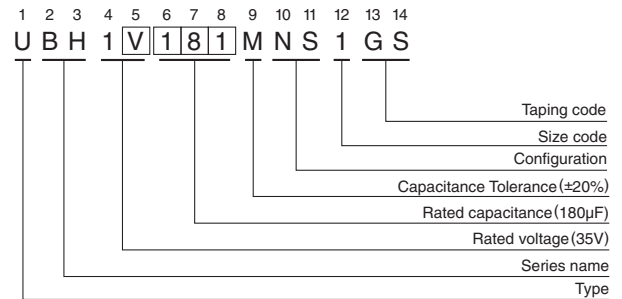

Voltage		
V	25	35
Code	E	V

Frequency coefficient of rated ripple current

Frequency	120 Hz	300 Hz	1 kHz	10kHz or more
Coefficient	0.67	0.79	0.91	1.00

Dimensions

Rated Voltage (V) (code)	Rated Capacitance (μF)	Case Size φD×L (mm)	tan δ	Leakage Current (μA) (at 20°C after 2 minutes)	ESR (Ω) max.		Rated Ripple (mArms) (150°C/100kHz)	Part Number
					Initial 20°C 100kHz	Initial -40°C 100kHz		
25 (1E)	150	8×10	0.16	37.5	0.26	4.5	80	UBH1E151MNS1GS
	270	10×10	0.16	67.5	0.15	2.0	120	UBH1E271MNS1GS
35 (1V)	100	8×10	0.14	35.0	0.26	4.5	80	UBH1V101MNS1GS
	180	10×10	0.14	63.0	0.15	2.0	120	UBH1V181MNS1GS

● For taping specifications, recommended land size/soldering by reflow and minimum order quantity, please refer to the Guidelines for Aluminum Electrolytic Capacitors.

ALUMINUM ELECTROLYTIC CAPACITORS



Chip Type, For Audio Equipment
Wide Temperature Range



- Chip type acoustic series within the wide temperature range.
- Applicable to automatic mounting machine fed with carrier tape.
- Compliant to the RoHS directive (2011/65/EU, (EU)2015/863).
- AEC-Q200 compliant. Please contact us for details.

Specifications

Item	Performance Characteristics							
Category Temperature Range	-40 to +105°C							
Rated Voltage Range	6.3 to 50V							
Rated Capacitance Range	1 to 1000μF							
Capacitance Tolerance	±20% (120Hz, 20°C)							
Leakage Current ※	After 1 minute's application of rated voltage at 20°C, leakage current is not more than 0.03 CV or 4 (μA), whichever is greater.							
Tangent of loss angle (tan δ)	Measurement frequency : 120Hz at 20°C							
	Rated voltage (V)	6.3	10	16	25	35	50	
Stability at Low Temperature	Measurement frequency : 120Hz							
	Impedance ratio	Z(-25°C) / Z(+20°C)	4	3	2	2	2	
	(max.)	Z(-40°C) / Z(+20°C)	8	5	4	3	3	
Endurance	The specifications listed at right shall be met when the capacitors are restored to 20°C after the rated voltage is applied for 1000 hours at 105°C.						Capacitance change	Within ±20% of the initial capacitance value
							tan δ	200% or less than the initial specified value
Shelf Life	After storing the capacitors under no load at 105°C for 1000 hours and then performing voltage treatment based on JIS C 5101-4 clause 4.1 at 20°C, they shall meet the specified values for the endurance characteristics listed above.						Leakage current	Less than or equal to the initial specified value
Resistance to soldering heat	The capacitors are kept on a hot plate for 30 seconds, which is maintained at 250°C. The capacitors shall meet the characteristic requirements listed at right when they are removed from the plate and restored to 20°C.						Capacitance change	Within ±10% of the initial capacitance value
							tan δ	Less than or equal to the initial specified value
Marking	Black print on the case top.						Leakage current	Less than or equal to the initial specified value

※ I : Leakage Current (μA), C : Rated Capacitance (μF), V : Rated Voltage (V)

Chip Type

Type numbering system (Example : 6.3V 100μF)

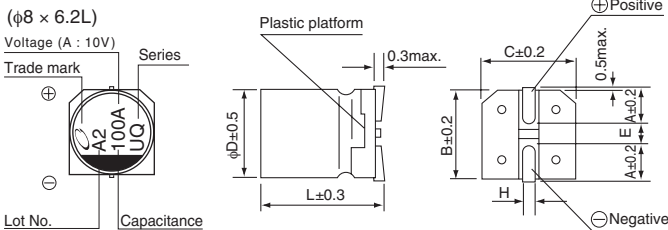
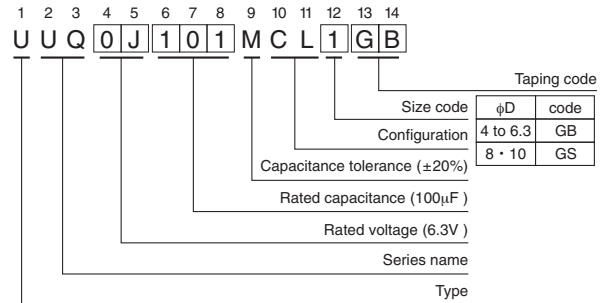
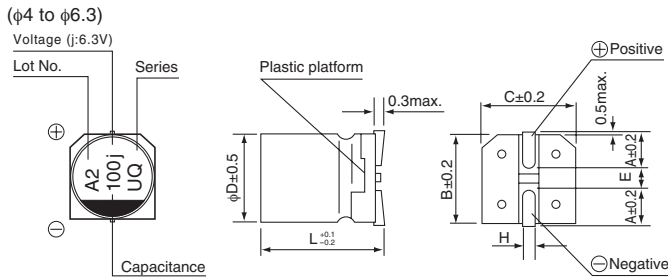

φD × L	4 × 5.4	5 × 5.4	6.3 × 5.4	8 × 6.2	8 × 10	10 × 10
A	1.8	2.1	2.4	3.3	2.9	3.2
B	4.3	5.3	6.6	8.3	8.3	10.3
C	4.3	5.3	6.6	8.3	8.3	10.3
E	1.0	1.3	2.2	2.3	3.1	4.5
L	5.4	5.4	5.4	6.2	10	10
H	0.5 to 0.8	0.5 to 0.8	0.5 to 0.8	0.5 to 0.8	0.8 to 1.1	0.8 to 1.1

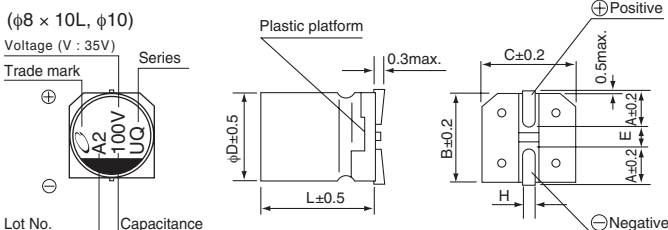

Voltage	6.3	10	16	25	35	50
Code	j	A	C	E	V	H

Frequency coefficient of rated ripple current

Frequency	50 Hz	120 Hz	300 Hz	1 kHz	10 kHz or more
Coefficient	0.70	1.00	1.17	1.36	1.50

● Dimension table in next page.

UUQ

■ Dimensions

Rated Voltage (V) (code)	Rated Capacitance (μF)	Case Size φD×L (mm)	tan δ	Leakage Current (μA) (at 20°C after 1 minute)	Rated Ripple (mArms) (105°C/120Hz)	Part Number
6.3 (0J)	22	4×5.4	0.30	4.158	22	UUQ0J220MCL1GB
	33	5×5.4	0.30	6.237	30	UUQ0J330MCL1GB
	47	5×5.4	0.30	8.883	36	UUQ0J470MCL1GB
	100	6.3×5.4	0.30	18.9	60	UUQ0J101MCL1GB
	220	8×6.2	0.30	41.58	102	UUQ0J221MCL1GS
	220	8×10	0.30	41.58	210	UUQ0J221MCL6GS
	330	8×6.2	0.30	62.37	102	UUQ0J331MCL1GS
	330	8×10	0.30	62.37	210	UUQ0J331MCL6GS
	470	8×10	0.30	88.83	210	UUQ0J471MCL1GS
	470	10×10	0.30	88.83	310	UUQ0J471MCL6GS
	1000	10×10	0.30	189	310	UUQ0J102MCL1GS
10 (1A)	10	4×5.4	0.26	4	22	UUQ1A100MCL1GB
	22	5×5.4	0.26	6.6	27	UUQ1A220MCL1GB
	33	5×5.4	0.26	9.9	35	UUQ1A330MCL1GB
	47	6.3×5.4	0.26	14.1	46	UUQ1A470MCL1GB
	100	6.3×5.4	0.26	30	60	UUQ1A101MCL1GB
	100	8×6.2	0.26	30	90	UUQ1A101MCL6GS
	220	8×6.2	0.26	66	102	UUQ1A221MCL1GS
	220	8×10	0.26	66	210	UUQ1A221MCL6GS
	330	8×10	0.26	99	210	UUQ1A331MCL1GS
	330	10×10	0.26	99	310	UUQ1A331MCL6GS
	470	8×10	0.26	141	210	UUQ1A471MCL1GS
470	10×10	0.26	141	310	UUQ1A471MCL6GS	
16 (1C)	10	4×5.4	0.22	4.8	18	UUQ1C100MCL1GB
	22	5×5.4	0.22	10.56	30	UUQ1C220MCL1GB
	33	6.3×5.4	0.22	15.84	40	UUQ1C330MCL1GB
	47	6.3×5.4	0.22	22.56	50	UUQ1C470MCL1GB
	100	8×6.2	0.22	48	102	UUQ1C101MCL1GS
	100	8×10	0.22	48	210	UUQ1C101MCL6GS
	220	8×10	0.22	105.6	210	UUQ1C221MCL1GS
	220	10×10	0.22	105.6	310	UUQ1C221MCL6GS
	330	8×10	0.22	158.4	210	UUQ1C331MCL1GS
	330	10×10	0.22	158.4	310	UUQ1C331MCL6GS
	470	8×10	0.22	225.6	210	UUQ1C471MCL1GS
470	10×10	0.22	225.6	310	UUQ1C471MCL6GS	
25 (1E)	4.7	4×5.4	0.16	4	13	UUQ1E4R7MCL1GB
	10	5×5.4	0.16	7.5	23	UUQ1E100MCL1GB
	22	6.3×5.4	0.16	16.5	38	UUQ1E220MCL1GB
	33	6.3×5.4	0.16	24.75	48	UUQ1E330MCL1GB
	47	8×6.2	0.16	35.25	66	UUQ1E470MCL1GS
	100	8×10	0.16	75	155	UUQ1E101MCL1GS
	220	10×10	0.16	165	300	UUQ1E221MCL1GS



■ Dimensions

Rated Voltage (V) (code)	Rated Capacitance (μ F)	Case Size ϕ D \times L (mm)	$\tan \delta$	Leakage Current (μ A) (at 20°C after 1 minute)	Rated Ripple (mArms) (105°C/120Hz)	Part Number
35 (1V)	4.7	4 \times 5.4	0.13	4.935	15	UUQ1V4R7MCL1GB
	10	5 \times 5.4	0.13	10.5	25	UUQ1V100MCL1GB
	22	6.3 \times 5.4	0.13	23.1	42	UUQ1V220MCL1GB
	33	8 \times 6.2	0.13	34.65	59	UUQ1V330MCL1GS
	47	8 \times 10	0.13	49.35	155	UUQ1V470MCL1GS
	100	10 \times 10	0.13	105	300	UUQ1V101MCL1GS
	220	10 \times 10	0.13	231	300	UUQ1V221MCL1GS
50 (1H)	1	4 \times 5.4	0.12	4	6.2	UUQ1H010MCL1GB
	2.2	4 \times 5.4	0.12	4	11	UUQ1H2R2MCL1GB
	3.3	4 \times 5.4	0.12	4.95	14	UUQ1H3R3MCL1GB
	4.7	5 \times 5.4	0.12	7.05	19	UUQ1H4R7MCL1GB
	10	6.3 \times 5.4	0.12	15	30	UUQ1H100MCL1GB
	22	8 \times 6.2	0.12	33	51	UUQ1H220MCL1GS
	33	8 \times 10	0.12	49.5	140	UUQ1H330MCL1GS
	47	8 \times 10	0.12	70.5	180	UUQ1H470MCL1GS
	100	10 \times 10	0.12	150	220	UUQ1H101MCL1GS

- For taping specifications, recommended land size/soldering by reflow and minimum order quantity, please refer to the Guidelines for Aluminum Electrolytic Capacitors.

ALUMINUM ELECTROLYTIC CAPACITORS



Chip Type, For Audio Equipment
Wide Temperature Range



- Chip type acoustic series within the wide temperature range.
- Applicable to automatic mounting machine fed with carrier tape.
- Compliant to the RoHS directive (2011/65/EU, (EU)2015/863).
- AEC-Q200 compliant. Please contact us for details.



Specifications

Item	Performance Characteristics																
Category Temperature Range	-55 to +105°C																
Rated Voltage Range	10 to 35V																
Rated Capacitance Range	4.7 to 680μF																
Capacitance Tolerance	±20% (120Hz, 20°C)																
Leakage Current ※	After 2 minutes' application of rated voltage at 20°C, leakage current is not more than 0.01CV or 3 (μA), whichever is greater.																
Tangent of loss angle (tan δ)	Measurement frequency : 120Hz at 20°C																
	<table border="1"> <tr> <td>Rated voltage (V)</td> <td>10</td> <td>16</td> <td>25</td> <td>35</td> </tr> <tr> <td>tan δ (max.)</td> <td>0.26</td> <td>0.22</td> <td>0.16</td> <td>0.13</td> </tr> </table>	Rated voltage (V)	10	16	25	35	tan δ (max.)	0.26	0.22	0.16	0.13						
Rated voltage (V)	10	16	25	35													
tan δ (max.)	0.26	0.22	0.16	0.13													
Stability at Low Temperature	Measurement frequency : 120Hz																
	<table border="1"> <tr> <td colspan="2">Rated voltage (V)</td> <td>10</td> <td>16</td> <td>25</td> <td>35</td> </tr> <tr> <td rowspan="2">Impedance ratio (max.)</td> <td>Z(-25°C) / Z(+20°C)</td> <td>3</td> <td>2</td> <td>2</td> <td>2</td> </tr> <tr> <td>Z(-40°C) / Z(+20°C)</td> <td>5</td> <td>4</td> <td>3</td> <td>3</td> </tr> </table>	Rated voltage (V)		10	16	25	35	Impedance ratio (max.)	Z(-25°C) / Z(+20°C)	3	2	2	2	Z(-40°C) / Z(+20°C)	5	4	3
Rated voltage (V)		10	16	25	35												
Impedance ratio (max.)	Z(-25°C) / Z(+20°C)	3	2	2	2												
	Z(-40°C) / Z(+20°C)	5	4	3	3												
Endurance	The specifications listed at right shall be met when the capacitors are restored to 20°C after the rated voltage is applied for 2000 hours (1000 hours for 4.5L) at 105°C.																
Shelf Life	After storing the capacitors under no load at 105°C for 1000 hours and then performing voltage treatment based on JIS C 5101-4 clause 4.1 at 20°C, they shall meet the specified values for the endurance characteristics listed above.																
	<table border="1"> <tr> <td>Capacitance change</td> <td>Within ±30% of the initial capacitance value</td> </tr> <tr> <td>tan δ</td> <td>300% or less than the initial specified value</td> </tr> <tr> <td>Leakage current</td> <td>Less than or equal to the initial specified value</td> </tr> </table>	Capacitance change	Within ±30% of the initial capacitance value	tan δ	300% or less than the initial specified value	Leakage current	Less than or equal to the initial specified value										
Capacitance change	Within ±30% of the initial capacitance value																
tan δ	300% or less than the initial specified value																
Leakage current	Less than or equal to the initial specified value																
Resistance to soldering heat	The capacitors are kept on a hot plate for 30 seconds, which is maintained at 250°C. The capacitors shall meet the characteristic requirements listed at right when they are removed from the plate and restored to 20°C.																
	<table border="1"> <tr> <td>Capacitance change</td> <td>Within ±10% of the initial capacitance value</td> </tr> <tr> <td>tan δ</td> <td>Less than or equal to the initial specified value</td> </tr> <tr> <td>Leakage current</td> <td>Less than or equal to the initial specified value</td> </tr> </table>	Capacitance change	Within ±10% of the initial capacitance value	tan δ	Less than or equal to the initial specified value	Leakage current	Less than or equal to the initial specified value										
Capacitance change	Within ±10% of the initial capacitance value																
tan δ	Less than or equal to the initial specified value																
Leakage current	Less than or equal to the initial specified value																
Marking	Black print on the case top.																

※ I : Leakage Current (μA), C : Rated Capacitance (μF), V : Rated Voltage (V)

Chip Type

(φ4 × 4.5L, φ5 × 4.5L, φ6.3 × 4.5L)

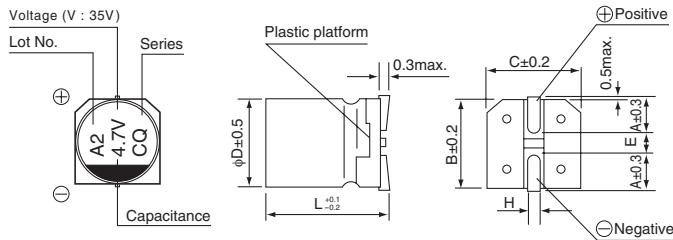

(φ6.3 × 5.8L, φ6.3 × 7.7L)

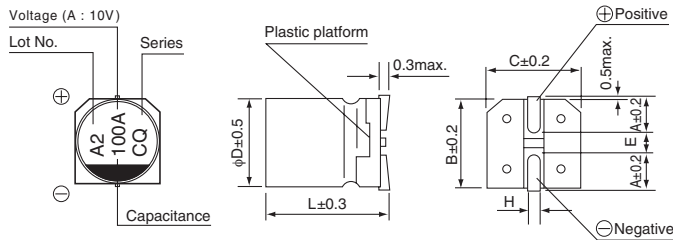

(φ8 × 10L, φ10 × 10L)

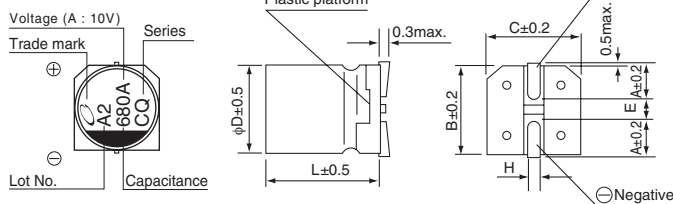

Type numbering system (Example : 35V 4.7μF)

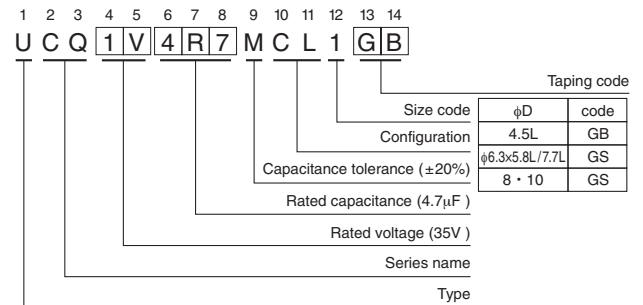

	(mm)						
φD × L	4 × 4.5	5 × 4.5	6.3 × 4.5	6.3 × 5.8	6.3 × 7.7	8 × 10	10 × 10
A	1.8	2.1	2.4	2.4	2.4	2.9	3.2
B	4.3	5.3	6.6	6.6	6.6	8.3	10.3
C	4.3	5.3	6.6	6.6	6.6	8.3	10.3
E	1.0	1.3	2.2	2.2	2.2	3.1	4.5
L	4.5	4.5	4.5	5.8	7.7	10	10
H	0.5 to 0.8	0.5 to 0.8	0.5 to 0.8	0.5 to 0.8	0.5 to 0.8	0.8 to 1.1	0.8 to 1.1

Rated voltage

V	10	16	25	35
Code	A	C	E	V

Frequency coefficient of rated ripple current

Frequency	50 Hz	120 Hz	300 Hz	1 kHz	10 kHz or more
Coefficient	0.70	1.00	1.17	1.36	1.50

● Dimension table in next page.

UCQ

■ Dimensions

Rated Voltage (V) (code)	Rated Capacitance (μF)	Case Size φD×L (mm)	tan δ	Leakage Current (μA) (at 20°C after 2 minutes)	Rated Ripple (mArms) (105°C/120Hz)	Part Number
10 (1A)	22	5×4.5	0.26	3	30	UCQ1A220MCL1GB
	33	5×4.5	0.26	3.3	30	UCQ1A330MCL1GB
	47	6.3×4.5	0.26	4.7	40	UCQ1A470MCL1GB
	100	6.3×5.8	0.26	10	100	UCQ1A101MCL1GS
	220	6.3×7.7	0.26	22	120	UCQ1A221MCL1GS
	330	8×10	0.26	33	250	UCQ1A331MCL1GS
	470	8×10	0.26	47	250	UCQ1A471MCL1GS
	680	10×10	0.26	68	400	UCQ1A681MCL1GS
16 (1C)	10	4×4.5	0.22	3	15	UCQ1C100MCL1GB
	22	5×4.5	0.22	3.52	30	UCQ1C220MCL1GB
	33	6.3×4.5	0.22	5.28	40	UCQ1C330MCL1GB
	47	6.3×4.5	0.22	7.52	40	UCQ1C470MCL1GB
	100	6.3×5.8	0.22	16	100	UCQ1C101MCL1GS
	220	8×10	0.22	35.2	250	UCQ1C221MCL1GS
	330	8×10	0.22	52.8	250	UCQ1C331MCL1GS
	470	10×10	0.22	75.2	400	UCQ1C471MCL1GS
25 (1E)	4.7	4×4.5	0.16	3	15	UCQ1E4R7MCL1GB
	10	5×4.5	0.16	3	30	UCQ1E100MCL1GB
	22	6.3×4.5	0.16	5.5	40	UCQ1E220MCL1GB
	33	6.3×4.5	0.16	8.25	40	UCQ1E330MCL1GB
	47	6.3×5.8	0.16	11.75	100	UCQ1E470MCL1GS
	100	6.3×7.7	0.16	25	120	UCQ1E101MCL1GS
	220	8×10	0.16	55	250	UCQ1E221MCL1GS
	330	10×10	0.16	82.5	400	UCQ1E331MCL1GS
	470	10×10	0.16	117.5	400	UCQ1E471MCL1GS
35 (1V)	4.7	4×4.5	0.13	3	15	UCQ1V4R7MCL1GB
	10	5×4.5	0.13	3.5	30	UCQ1V100MCL1GB
	22	6.3×4.5	0.13	7.7	40	UCQ1V220MCL1GB
	33	6.3×5.8	0.13	11.55	100	UCQ1V330MCL1GS
	47	6.3×7.7	0.13	16.45	120	UCQ1V470MCL1GS
	100	8×10	0.13	35	250	UCQ1V101MCL1GS
	220	10×10	0.13	77	400	UCQ1V221MCL1GS
	330	10×10	0.13	115.5	400	UCQ1V331MCL1GS

- For taping specifications, recommended land size/soldering by reflow and minimum order quantity, please refer to the Guidelines for Aluminum Electrolytic Capacitors.