

**NEC**<sup>®</sup>

# 1.9 GHz MEDIUM POWER BROADBAND SILICON MMIC AMPLIFIER

UPC1678B  
UPC1678G  
UPC1678P

T-74-13-01

## FEATURES

- HIGH OUTPUT POWER: +18 dBm
- EXCELLENT FREQUENCY RESPONSE:  
1.9 GHz TYP at 3 dB Down
- HIGH POWER GAIN: 23 dB TYP at 0.5 GHz
- SINGLE SUPPLY VOLTAGE: 5 V

## DESCRIPTION

The UPC1678 is a silicon monolithic integrated circuit designed as a wide-band amplifier covering the HF to UHF bands. The device features high output power, 18 dBm TYP, high gain, 23 dB TYP and operates from a single 5 volt supply. The UPC1678 is available in two package styles: an 8 lead ceramic flat pack (UPC1678B), an 8 pin mini flat (UPC1678G), and in chip form (UPC1678P).

UPC1678B/P  
INSERTION GAIN vs. FREQUENCY

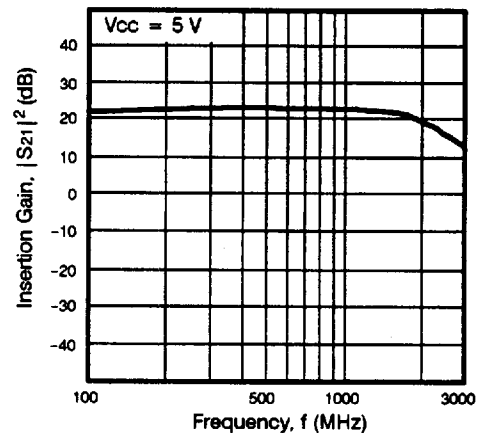

## ELECTRICAL CHARACTERISTICS (TA = 25°C, VCC = +5 V)

PART NUMBER PACKAGE OUTLINE			UPC1678B B08			UPC1678G G08			UPC1678P CHIP		
SYMBOLS	PARAMETERS AND CONDITIONS	UNITS	MIN	TYP	MAX	MIN	TYP	MAX	MIN	TYP	MAX
I <sub>CC</sub>	Circuit Current at No Input Signal	mA	40	49	60	40	49	60	40	49	60
GP	Power Gain at $f = 0.5$ GHz	dB	21	23	25	21	23	25	21	23	25
f <sub>3dB</sub>	Upper Limit Operating Frequency at 3 dB down below the Gain at 0.1 GHz	GHz		1.9		1.7	1.9			1.9	
PSAT	Saturated Output Power at $f = 0.5$ GHz	dBm	15.5	18		15.5	17.5		15.5	18	
NF	Noise Figure at $f = 0.5$ GHz	dB		6			6	8		6	
S <sub>11</sub>	Input Return Loss at $f = 0.5$ GHz	dB		13		11	14			13	
S <sub>22</sub>	Output Return Loss at $f = 0.5$ GHz	dB		4		1	4			4	
S <sub>12</sub>	Isolation at $f = 0.5$ GHz	dB			34		30	35			34
R <sub>TH</sub>	Thermal Resistance, Junction to Ambient (J-A)	°C/W			200			200 <sup>1</sup>			
R <sub>TH</sub>	Thermal Resistance, Junction to Case (J-C)	°C/W			50 <sup>2</sup>						

### Notes:

1. Mounted on 5 cm x 5 cm x 1.6 mm glass epoxy PWB.
2. Measured without heatsink.

**UPC1678B, UPC1678G, UPC1678P**

**ABSOLUTE MAXIMUM RATINGS** (TA = 25°C)

SYMBOLS	PARAMETERS	UNITS	RATINGS
Vcc	Supply Voltage	V	-0.5 to 6.0
PT	Total Power Dissipation UPC1678B, P UPC1678G	W mW	1.5' 330 <sup>2</sup>
Top	Operating Temperature UPC1678B, P UPC1678G	°C °C	-55 to +125 -40 to +85
TSTG	Storage Temperature UPC1678B, P UPC1678G	°C °C	-65 to +200 -55 to +150

Notes:

1. TCASE = +125 °C.
2. Mounted on 5 cm x 5 cm x 1.6 mm glass epoxy PWB at 85 °C.

**UPC1678B/P  
ISOLATION vs. FREQUENCY**

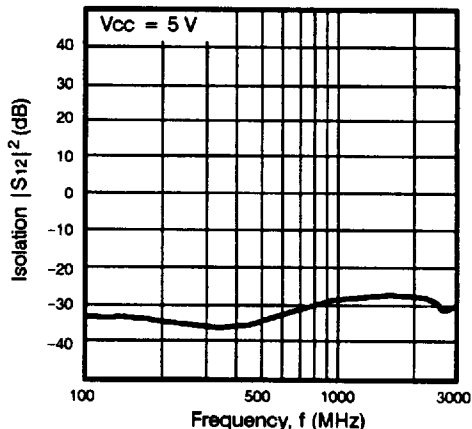

**TYPICAL PERFORMANCE CURVES** (TA = 25°C)

**UPC1678B/P  
INPUT RETURN LOSS vs. FREQUENCY**

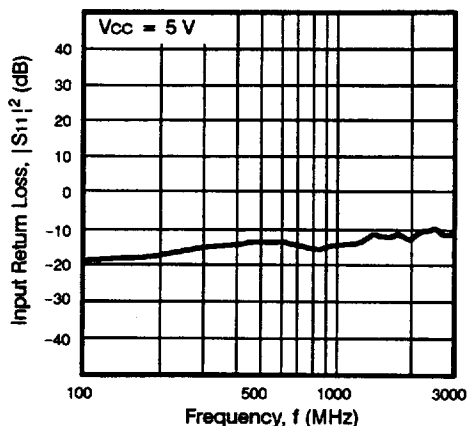

**UPC1678B/P  
OUTPUT RETURN LOSS vs. FREQUENCY**

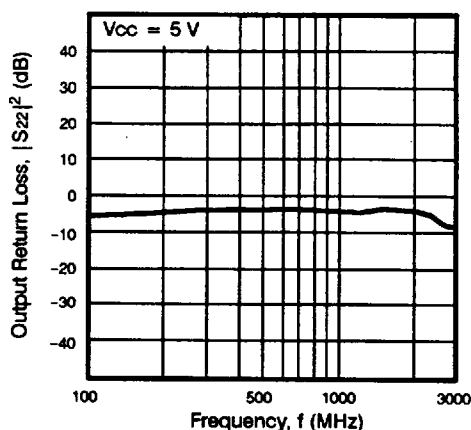

**UPC1678G  
INSERTION GAIN vs. FREQUENCY**

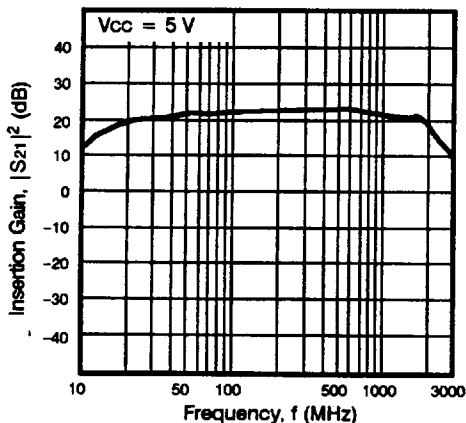

**UPC1678G  
ISOLATION vs. FREQUENCY**

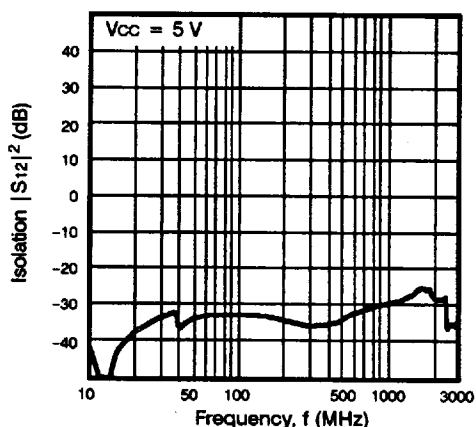

**TYPICAL PERFORMANCE CURVES** (TA = 25°C)

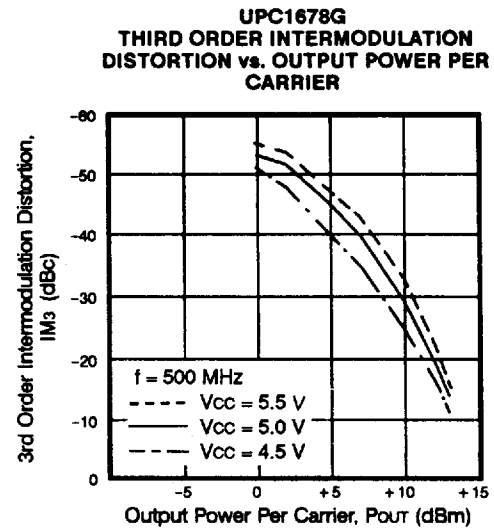
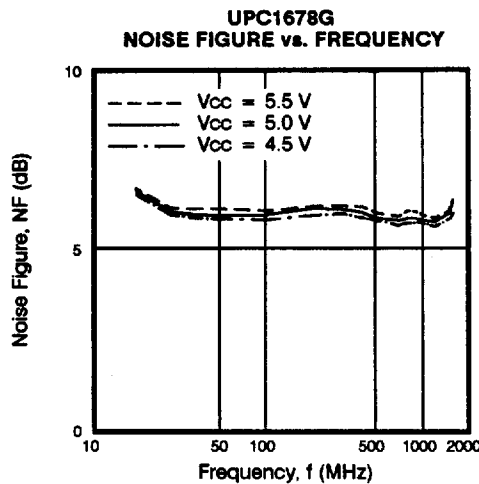
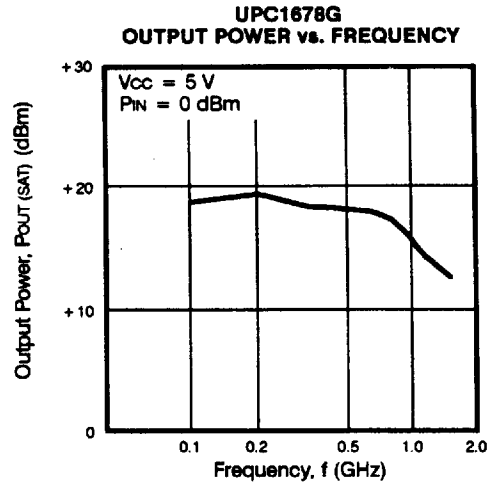
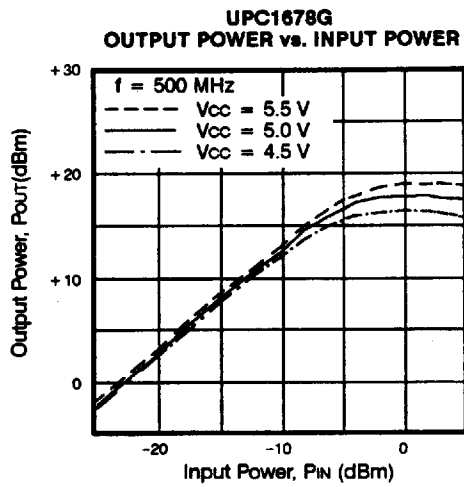
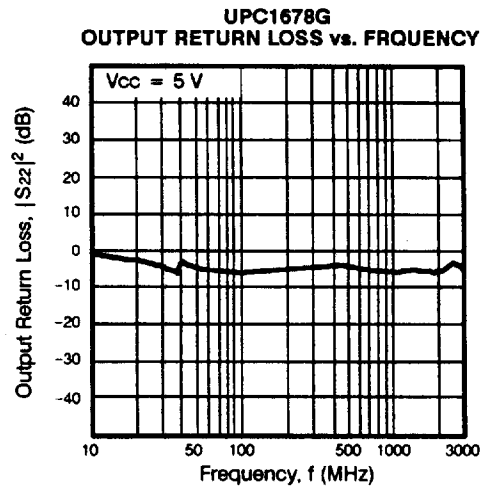
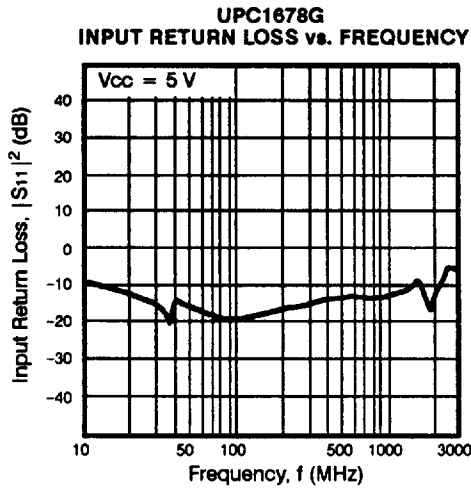

**UPC1678B, UPC1678G, UPC1678P**

**EQUIVALENT CIRCUIT**

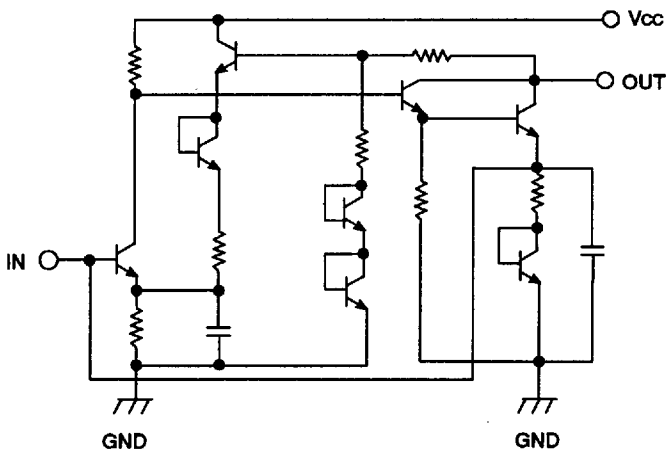

**TEST CIRCUIT**

**UPC1678B**

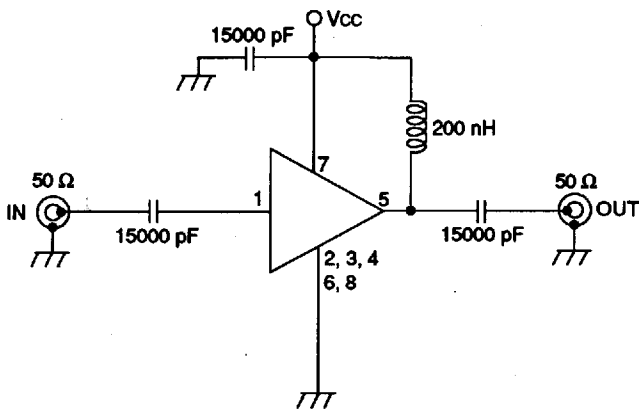

**UPC1678G**

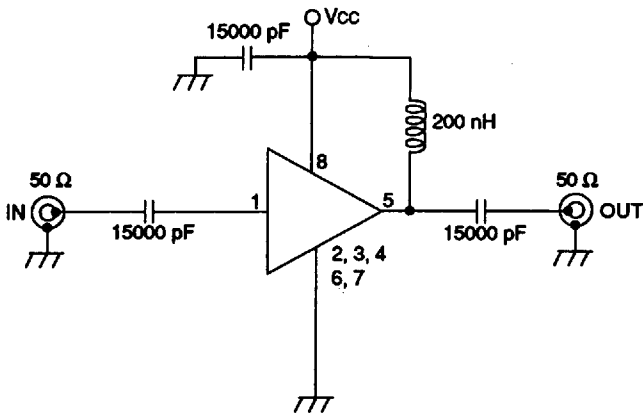

Precautions: 1) These devices are ESD sensitive. Use proper precautionary measures when handling and installing these devices.

**TYPICAL SCATTERING PARAMETERS** (TA = 25°C)

**UPC1678B**

Vcc = 5 V, Icc = 48 mA

FREQ (GHz)	S11		S21		S12		S22		K	S21 (dB)
	MAG	ANG	MAG	ANG	MAG	ANG	MAG	ANG		
0.1	0.144	144	10.7	23	0.018	25	0.717	81	1.43	20.6
0.2	0.122	138	12.9	-6	0.018	10	0.646	34	1.43	22.3
0.4	0.150	102	14.2	-47	0.020	25	0.668	-24	1.11	23.0
0.6	0.141	52	13.4	-83	0.030	22	0.642	-64	0.86	22.6
0.8	0.122	2	12.5	-112	0.036	8	0.603	-94	0.85	22.0
1.0	0.108	-51	11.9	-140	0.041	-7	0.586	-118	0.85	21.5
1.2	0.109	-103	11.5	-170	0.043	-19	0.584	-139	0.87	21.2
1.4	0.121	-154	11.0	160	0.043	-28	0.576	-160	0.93	20.8
1.6	0.140	161	10.1	128	0.043	-37	0.540	178	1.04	20.1
1.8	0.150	120	8.8	96	0.044	-42	0.465	156	1.24	18.9
2.0	0.139	88	7.3	66	0.046	-50	0.355	136	1.49	17.2

**UPC1678G**

Vcc = 5 V, Icc = 49 mA

FREQ (GHz)	S11		S21		S12		S22		K	S21 (dB)
	MAG	ANG	MAG	ANG	MAG	ANG	MAG	ANG		
0.05	0.168	167	10.8	36	0.016	33	0.737	90	1.50	20.6
0.10	0.121	154	12.5	9	0.019	13	0.617	46	1.48	21.9
0.20	0.134	140	13.4	-18	0.018	-4	0.623	10	1.45	22.6
0.40	0.206	96	14.1	-59	0.016	4	0.691	-34	1.28	23.0
0.60	0.250	54	13.6	-96	0.023	2	0.669	-71	0.95	22.7
0.80	0.258	19	12.7	-130	0.030	-16	0.624	-101	0.87	22.1
1.00	0.242	-12	12.1	-163	0.035	-31	0.599	-128	0.84	21.7
1.20	0.206	-43	11.6	164	0.040	-52	0.617	-157	0.79	21.3
1.40	0.165	-81	11.5	133	0.045	-70	0.611	176	0.77	21.2
1.60	0.111	-135	11.0	97	0.045	-89	0.648	142	0.76	20.8
1.80	0.071	143	9.8	58	0.047	-118	0.664	105	0.80	19.9
2.00	0.188	101	8.7	26	0.044	-134	0.595	65	1.00	18.8
2.20	0.220	60	7.2	-8	0.038	-154	0.545	28	1.40	17.2
2.40	0.252	35	5.9	-39	0.035	-174	0.480	-8	1.91	15.4
2.50	0.272	24	5.4	-55	0.035	176	0.433	-27	2.16	14.6

**UPC1678P**

Vcc = 5 V, Icc = 49 mA

FREQ (GHz)	S11		S21		S12		S22		K	S21 (dB)
	MAG	ANG	MAG	ANG	MAG	ANG	MAG	ANG		
0.1	0.151	158	14.2	-12	0.025	20	0.567	-4	1.19	23.0
0.2	0.337	164	18.0	-18	0.011	27	0.794	-14	1.14	25.1
0.4	0.252	80	13.0	-52	0.027	27	0.525	-35	1.10	22.2
0.6	0.225	48	11.2	-67	0.032	28	0.515	-40	1.07	21.0
0.8	0.234	25	10.7	-82	0.039	29	0.522	-54	0.92	20.6
1.0	0.250	0	10.0	-97	0.043	26	0.533	-60	0.86	20.0
1.2	0.270	-24	9.7	-112	0.049	21	0.585	-68	0.72	19.7
1.4	0.296	-46	9.4	-130	0.055	15	0.646	-80	0.59	19.4
1.6	0.321	-68	9.0	-148	0.058	8	0.706	-93	0.48	19.1
1.8	0.349	-89	8.4	-166	0.060	0	0.746	-108	0.42	18.5
2.0	0.354	-111	7.6	174	0.057	-8	0.752	-122	0.45	17.6
2.2	0.357	-130	6.6	157	0.055	-18	0.749	-137	0.52	16.5
2.4	0.348	-147	5.6	141	0.051	-24	0.721	-148	0.73	15.1
2.6	0.335	-163	4.8	127	0.043	-28	0.678	-160	1.16	13.7
2.8	0.315	-175	4.1	115	0.037	-28	0.635	-169	1.78	12.3
3.0	0.300	176	3.4	104	0.034	-26	0.594	-177	2.55	10.7

**5**

**UPC1678B, UPC1678G, UPC1678P**

**OUTLINE DIMENSIONS**

**UPC1678B  
OUTLINE B08  
(Units in mm)**

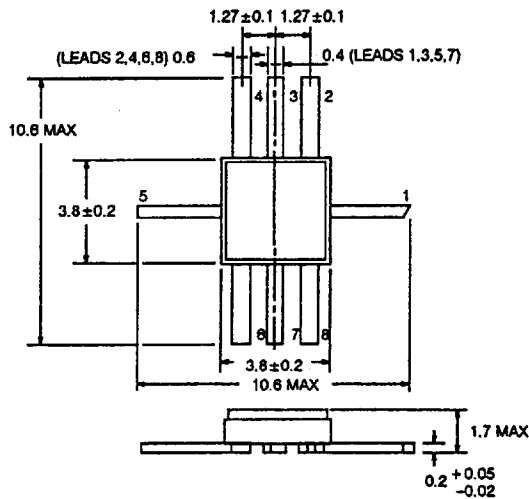

**LEAD CONNECTIONS**

- |          |           |  |
|----------|-----------|--|
| 1. INPUT | 5. OUTPUT | Lead Material: Cu, Fe, Cu                        |
| 2. GND   | 6. GND    | Lead Plating: Ni, Au                             |
| 3. GND   | 7. Vcc    | Package material: Al <sub>2</sub> O <sub>3</sub> |
| 4. GND   | 8. GND    |  |

**UPC1678G  
OUTLINE G08  
(Units in mm)**

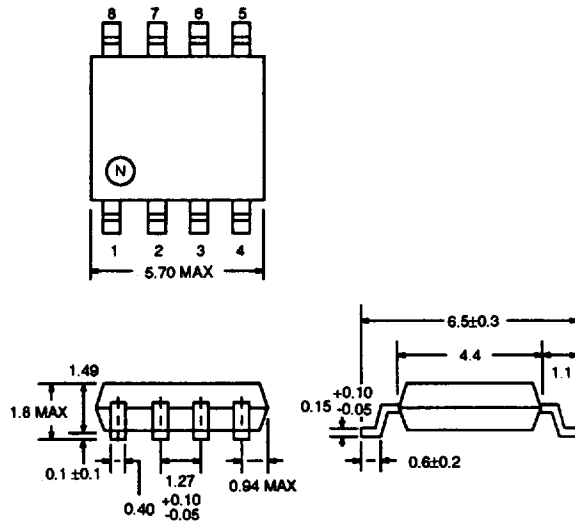

**LEAD CONNECTIONS**

- |          |           |                              |
|----------|-----------|------------------------------|
| 1. INPUT | 5. OUTPUT | Lead Material: Alloy 42      |
| 2. GND   | 6. GND    | Lead Plating: Lead Tin Alloy |
| 3. GND   | 7. GND    |                              |
| 4. GND   | 8. Vcc    |                              |

**UPC1678P  
CHIP  
(Units in μm)**

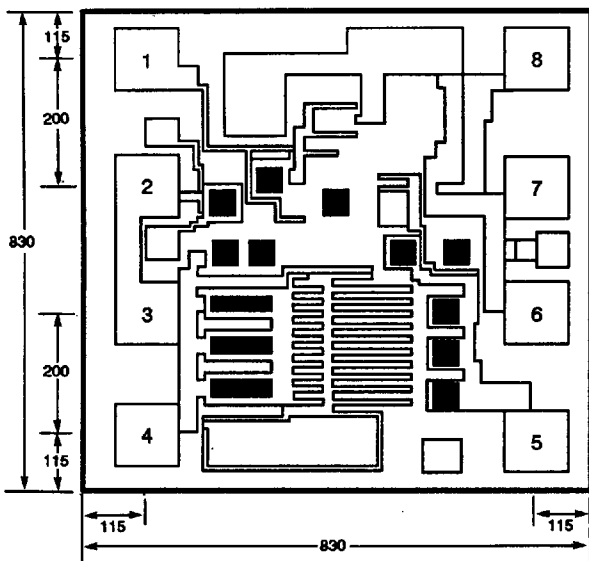

**PAD CONNECTIONS**

- |          |           |                                 |
|----------|-----------|---------------------------------|
| 1. INPUT | 5. OUTPUT | Die Thickness: 160 μm           |
| 2. GND   | 6. GND    | Ti/Pt/Au Metallization          |
| 3. GND   | 7. GND    | Bonding Pad Size: 100 μm square |
| 4. GND   | 8. Vcc    |                                 |