

Metal Element Current Sense Resistor

ULR Series

- Robust metal strip able to withstand high temperature and high current.
- Low TCR and Inductance
- Resistance Range from 0.5 mΩ to 15 mΩ
- Power ratings from 1W to 3W in 1206, 2010 and 2512 chip size
- Designed for current sense circuits in power electronic systems
- Higher wattage devices feature PCB clearance gap to maximize thermal performance



Electrical Data

IRC Type	Coating ²	Power rating at 80°C (Watts)	Standard Resistance Values (mΩ) ¹	TCR (±ppm/°C)	Tolerance (±%)	Dielectric Withstanding Voltage (Volts)
1206 Chip Size						
ULRG1	Green	1	1, 2, 3, 5, 7, 10	50	1, 5	100
2010 Chip Size						
ULRG15	Green	1.5	1, 2, 3, 5, 7, 10	50	1, 5	100
2512 Chip Size						
ULRG1	Green	1	11, 12, 15	50	1, 5	200
ULRG2		2	7, 8, 9, 10	50		
ULRG25		2.5	4, 4.5, 5, 6	50		
ULRG3		3	0.5, 0.75 1, 1.5, 2, 2.5, 3	100 50		
ULRB2	Black	2	2.5, 3	150	1, 5	200
			4, 5	100		
			6, 7	75		
			0.5, 0.75, 1, 1.5, 2	50		

Notes:

¹ Non-standard resistance values available (contact factory). For resistance values above 20 mΩ, please refer to our LRC / LRF / LRMA series. ² Black coating = wave or IR reflowsoldering; Green coating = only IR reflow soldering: Wave reflow - solder mask must match the W and D dimensions on page 2 of data sheet. ³ Package sizes 2010 and 1206 with the green coating are uncoated on the top surface and unmarked for resistance value.

Environmental Data

Test	
Short Term Overload (5x rated power for 5 seconds)	$\Delta R/R \leq \pm 0.5\% + 0.5 \text{ m}\Omega$ (black); $\Delta R/R \leq \pm 1\%$ (green)
Load at rated power (1000 hours cyclic load @ 70°C)	$\Delta R/R \leq \pm 1\% + 0.5 \text{ m}\Omega$ (black); $\Delta R/R \leq \pm 1\%$ (green)
Temperature Cycling (-55°C to +150°C; 1000 cycles)	$\Delta R/R \leq \pm 0.5\% + 0.5 \text{ m}\Omega$ (black); $\Delta R/R \leq \pm 1\%$ (green)
Dry Heat (+170°C, no load; 1000 hours)	$\Delta R/R \leq \pm 1\% + 0.5 \text{ m}\Omega$ (black); $\Delta R/R \leq \pm 1\%$ (green)
Resistance to Solder Heat (260°C for 10 seconds)	$\Delta R/R \leq \pm 0.5\% + 0.5 \text{ m}\Omega$ (black); $\Delta R/R \leq \pm 1\%$ (green)
Solderability (235°C for 2 seconds)	Minimum 95% coverage
Resistance to Solvents	No deterioration of protective coating or marking
Operating Temperature	-55°C to 170°C

General Note

TT electronics reserves the right to make changes in product specification without notice or liability. All information is subject to TT electronics' own data and is considered accurate at time of going to print.

Physical Data

Coating	Resistance Value (mΩ)	L	W	T	D
2010 Chip Size (1.5 Watt)					
Green	1	5.08±0.25	2.54±0.15	0.60±0.20	1.84±0.25
	2.0, 6.0, 7.0, 8.0				1.54±0.25
	3				1.04±0.25
	4.0, 5.0				1.84±0.25
1206 Chip Size (1 Watt)					
Green	1.0, 4.0, 5.0, 6.0	3.20±0.25	1.60±0.10	0.60±0.20	1.10±0.25
	2.0, 3.0, 10				0.60±0.25
	7.0, 8.0, 9.0				0.90±0.25
2512 Chip Size (1 Watt, 2 Watt, 2.5 Watt, and 3 Watt)					
Green	0.5	6.35 ± 0.25	3.00 ± 0.2	0.6 ± 0.2	2.68 ± 0.25
	0.75				2.48 ± 0.25
	1.0, 6.0				1.93 ± 0.25
	1.5, 6.5, 7.0				1.43 ± 0.25
	2 - 3				1.18 ± 0.25
	4.0, 4.5				2.18 ± 0.25
	5.0, 6.0				1.93 ± 0.25
	8.0 - 15				1.18 ± 0.25
Black	0.5	6.35 ± 0.25	3.18 ± 0.25	1.25 ± 0.2 ¹	1.30 ± 0.38
	0.75			0.75 ± 0.2 ¹	
	1			0.65 ± 0.2 ¹	
	1.5			0.45 ± 0.2 ¹	
	2			0.35 ± 0.2 ¹	
	2.5			0.65 ± 0.2 ¹	
	3			0.55 ± 0.2 ¹	
	4			0.45 ± 0.2 ¹	
	5			0.35 ± 0.2 ¹	
	6			0.32 ± 0.2 ¹	
	6.5			0.3 ± 0.2 ¹	
	7			0.27 ± 0.2 ¹	

Note:

¹ Dimensions are for reference only. All units are displayed in mm.

General Note

TT electronics reserves the right to make changes in product specification without notice or liability. All information is subject to TT electronics' own data and is considered accurate at time of going to print.

Electrical Connections

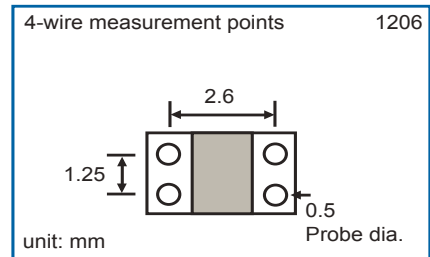
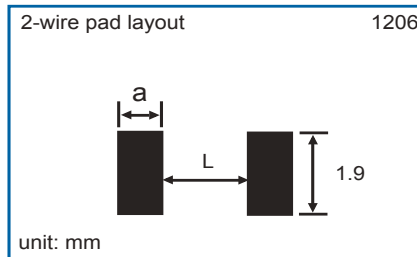
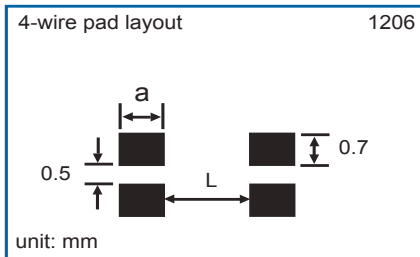
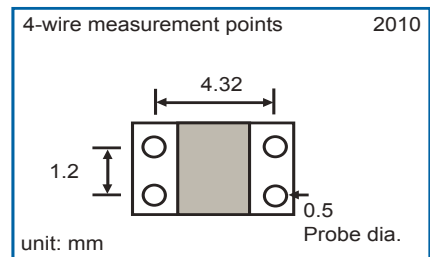
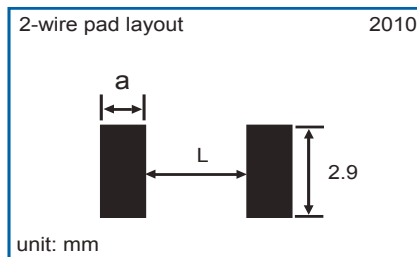
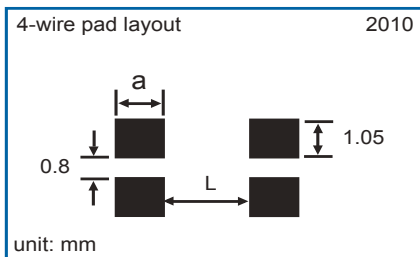
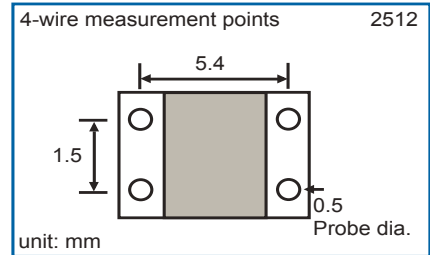
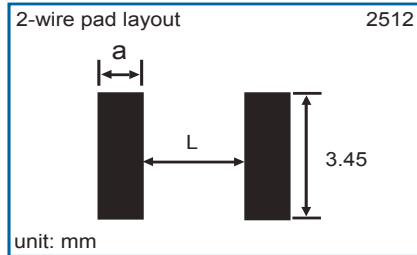
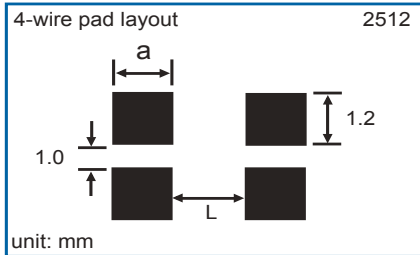

Package	Resistance (mΩ)	a	L
2512 - Black	All	2.7	2.9
2512 - Green	0.5	3.13	0.52
	0.75	2.93	0.94
	1	2.38	2.04
	1.5	1.88	3.04
	2 - 3	1.63	3.54
	4, 4.5	2.63	1.54
	5 - 6	2.38	2.04
	6.5, 7	1.88	3.04
8 - 15	1.63	3.54	

Package	Resistance (mΩ)	a	L
2010 - Green	1	1.55	0.55
	2 - 3	1.05	1.55
	4 - 6	1.55	0.55
	7 - 9	1.35	0.95
	10	1.05	1.55
1206 - Green	1	2.29	0.95
	2	1.99	1.55
	3	1.49	2.55
	4 - 5	2.29	0.95
	6 - 8	1.99	1.55
	9 - 10	1.74	2.05

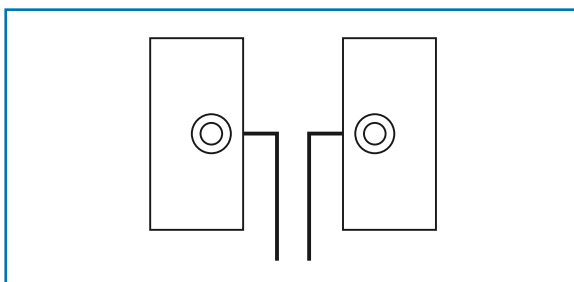

Vias with copper traces on internal layers.

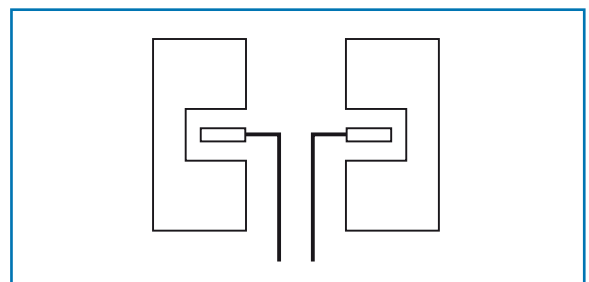

Sense traces on Solder pads beneath the chip

General Note

TT electronics reserves the right to make changes in product specification without notice or liability. All information is subject to TT electronics' own data and is considered accurate at time of going to print.

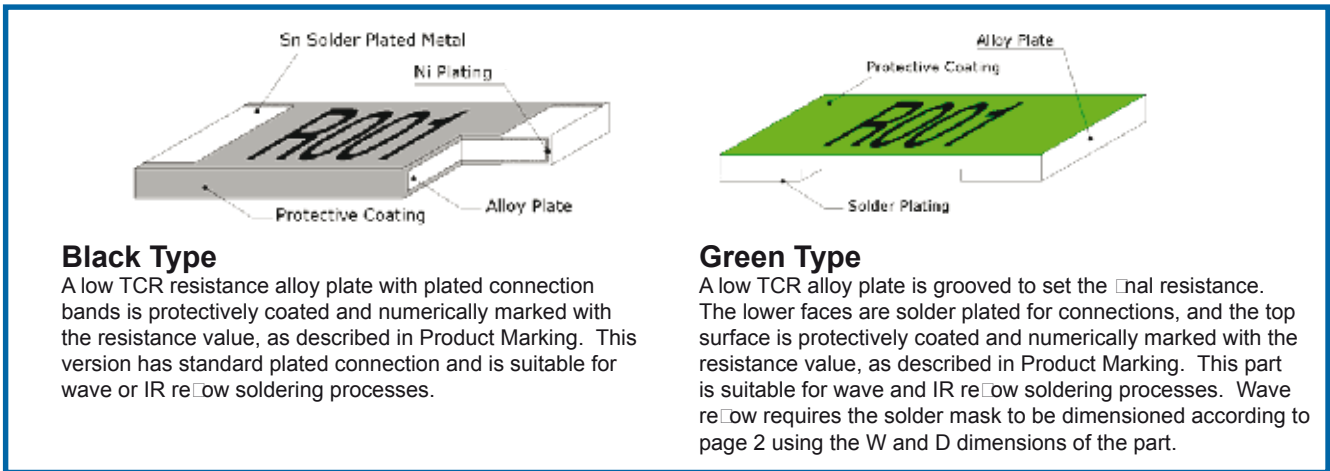

Power Derating Curve

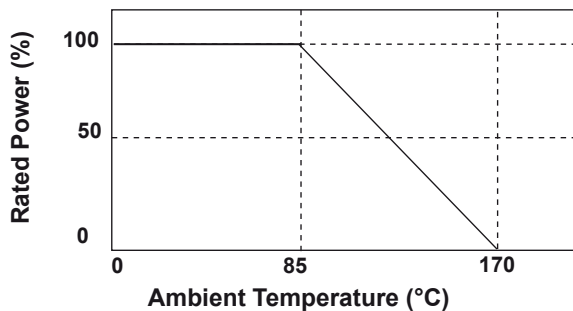

Note:

The power derating curve is a guidance based on a conservative design model. The ULR is a solid metal alloy construction that can withstand significantly greater operating temperatures than the conservative model permits. The protective coating will operate up to 260°C and the alloy can withstand in excess of 350°C. Therefore, the system thermal design will be a more significant design parameter due to the heat limitations of the solder joint.

Plastic Tape Specification

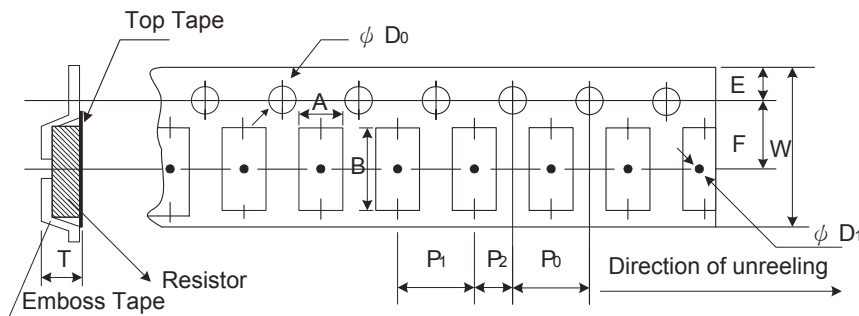

Type	Resistance (mΩ)	A	B	W	E	F	P ₀	P ₁	P ₂	ΦD ₀	ΦD ₁	T	Quantity (EA)
LR06	1 - 10	1.90 ± 0.1	3.60 ± 0.1	8.0 ± 0.2	1.75 ± 0.1	3.5 ± 0.05	4.0 ± 0.1	4.0 ± 0.1	2.0 ± 0.05	1.55 ± 0.05	1.0min.	0.87 ± 0.1	2,000
LR10	1 - 10	2.85 ± 0.1	5.55 ± 0.1	12.0 ± 0.2	1.75 ± 0.1	5.5 ± 0.05	4.0 ± 0.1	4.0 ± 0.1	2.0 ± 0.05	1.55 ± 0.05	1.4min	0.85 ± 0.1	2,000
LR12	0.50 - 0.75	3.40 ± 0.1	6.75 ± 0.1	12.0 ± 0.1	1.75 ± 0.1	5.5 ± 0.05	4.0 ± 0.1	4.0 ± 0.1	2.0 ± 0.05	1.55 ± 0.05	1.4min	1.45 ± 0.2	2,000
	1 - 10											0.81 ± 0.1	
LR12 (G)	0.50 - 15	3.40 ± 0.1	6.75 ± 0.1	12.0 ± 0.1	1.75 ± 0.1	5.5 ± 0.05	4.0 ± 0.1	4.0 ± 0.1	2.0 ± 0.05	1.55 ± 0.05	1.4min	0.81 ± 0.1	2,000

Note:

- The cumulative tolerance of 10 sprocket hole pitch is ± 0.2 mm.
- Carrier camber shall not be more than 1 mm per 100 mm through a length of 250 mm.
- A & B measured 0.3 mm from the bottom of the packet.
- T measured at a point on the inside bottom of the packet to the top surface of the carrier.
- Pocket position relative to sprocket hole is measured as the true position of the pocket and not the pocket hole.

General Note

TT electronics reserves the right to make changes in product specification without notice or liability. All information is subject to TT electronics' own data and is considered accurate at time of going to print.

IRC Solder Reflow Recommendations

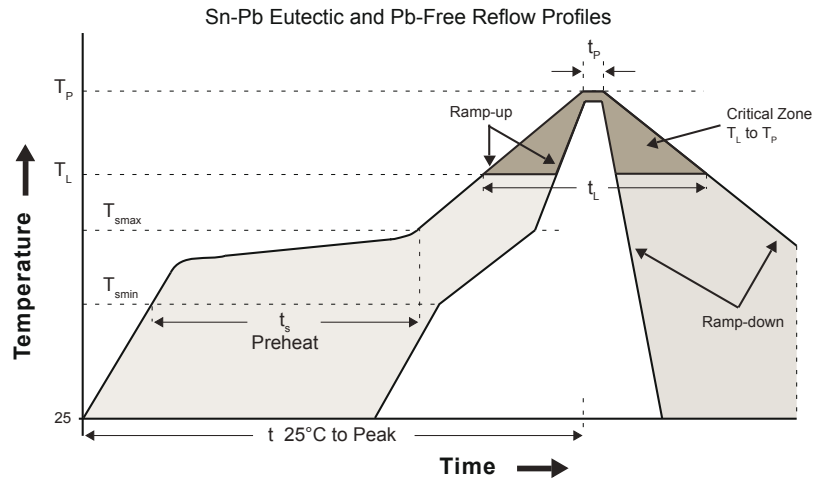

* Based on Industry Standards and IPC recommendations

Profile Feature	Sn-Pb Eutectic Assembly	Pb-Free Assembly
Average Ramp-up rate (T_{smax} to T_p)	3°C / second max.	3°C / second max.
Preheat		
- Temperature Min (T_{smin})	100°C	150°C
- Temperature Max (T_{smax})	150°C	200°C
- Time (T_{smin} to T_{smax}) (t_s)	60 - 120 seconds	60 - 180 seconds
Time maintained above		
- Temperature (T_L)	183°C	217°C
- Time (t_L)	60 - 150 seconds	60 - 150 seconds
Peak Temperature (T_p)	See Table 1	See Table 2
Time within 5°C of actual Peak Temperature (t_p) ²	10 - 30 seconds	20 - 40 seconds
Ramp-down Rate	6°C / second max.	6°C / second max.
Time 25°C to Peak Temperature	6 minutes max.	8 minutes max.

Note 1: All temperatures refer to topside of the package, measured on the package body surface.

Note 2: Time within 5 °C of actual peak temperature (t_p) specified for the reflow profiles is a "supplier" minimum and a "user" maximum.

Table 1: SnPb Eutectic Process - Package Peak Reflow Temperatures		
Package Thickness	Volume mm ³ < 350	Volume mm ³ ≥ 350
< 2.5 mm	240 +0/-5°C	225 +0/-5°C
≥ 2.5 mm	225 +0/-5°C	225 +0/-5°C

Note 1: Package volume excludes external terminals (balls, bumps, lands, leads) and/or non-integral heat sinks.

Table 2: Pb-free Process - Package Peak Reflow Temperatures			
Package Thickness	Volume mm ³ < 350	Volume mm ³ 350 - 2000	Volume mm ³ > 2000
< 1.6 mm	260°C *	260°C *	260°C *
1.6 mm - 2.5 mm	260°C *	250°C *	245°C *
≥ 2.5 mm	250°C *	245°C *	245°C *

Note 2: The maximum component temperature reached during reflow depends on package thickness and volume. The use of convection reflow processes reduces the thermal gradients between packages. However, thermal gradients due to differences in thermal mass of SMD packages may still exist.

Note 3: Components intended for use in "lead-free" assembly process shall be evaluated using the "lead-free" peak temperature and profiles defined in Table 1, 2 and reflow profile whether or not lead-free.

* Tolerance: The device manufacturer/supplier shall assure process compatibility up to and including the stated classification temperature at the rated MSL level.

General Note

TT electronics reserves the right to make changes in product specification without notice or liability. All information is subject to TT electronics' own data and is considered accurate at time of going to print.

Packaging Quantity	
Series	Emboss Plastic Tape
2512	2,000
2010	2,000
1206	2,000

Ordering Data

Specify type, resistance, tolerance, ROHS compliance and packaging.
Example: Metal Element Current Sense Resistor, 1-watt, 10 mΩ resistor.

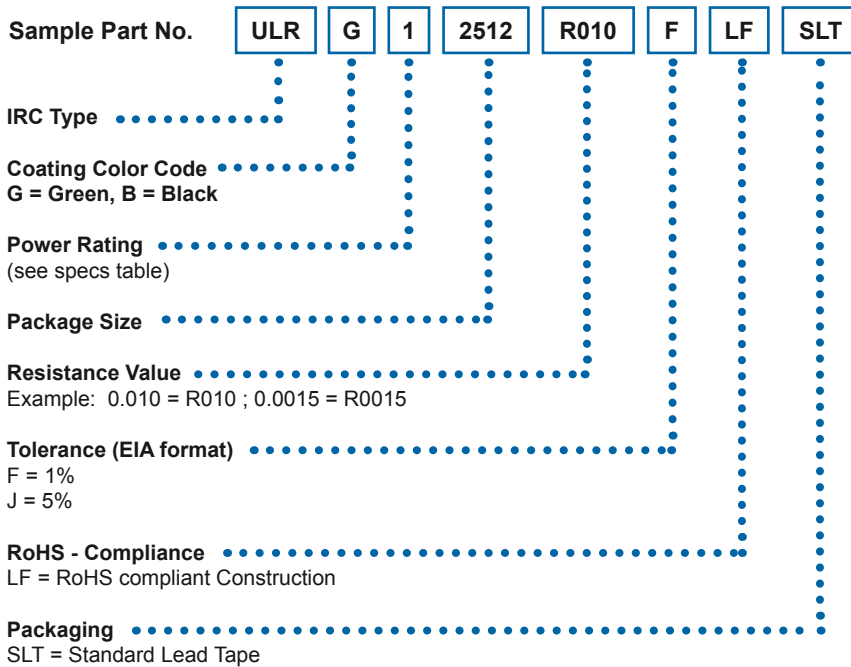

Product Marking

- Part resistance is indicated by using two marking notation styles:
- 4-digit: R002 = 2 mΩ; R designates the decimal location in ohms.
 - 4-digit: 1M50 = 1.5 mΩ; M designates the decimal location in milli-ohm.
 - 3-digit: 1M5 = 1.5 mΩ; M designates the decimal location in milli-ohm.

General Note

TT electronics reserves the right to make changes in product specification without notice or liability.
All information is subject to TT electronics' own data and is considered accurate at time of going to print.

