

DUAL SOLENOID/MOTOR DRIVER —PULSE-WIDTH MODULATED CURRENT CONTROL

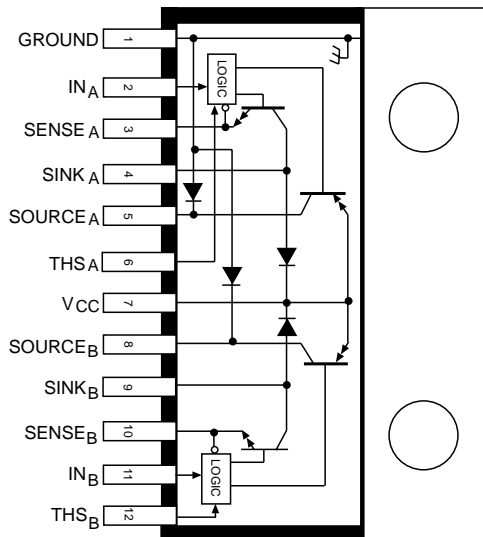

Dwg. No. D-1001

ABSOLUTE MAXIMUM RATINGS at $T_J \leq +150^\circ\text{C}$

Supply Voltage, V_{CC}	45 V
Peak Output Current, I_{OUT}	± 4 A
Input Voltage Range, V_{IN}	-0.3 V to +7.0 V
Package Power Dissipation, P_D	See Graph
Operating Temperature Range, T_A	-20°C to $+85^\circ\text{C}$
Storage Temperature Range, T_S	-55°C to $+150^\circ\text{C}$

NOTE: Output current rating may be limited by duty cycle, ambient temperature, and heat sinking. Under any set of conditions, do not exceed the specified peak current and a junction temperature of $+150^\circ\text{C}$.

Using PWM to minimize power dissipation and maximize load efficiency, the UDN2962W dual driver is recommended for impact printer solenoids and stepper motors. It is comprised of two source/sink driver pairs rated for continuous operation to ± 3 A. It can be connected to drive two independent loads or a single load in the full-bridge configuration. Both drivers include output clamp/flyback diodes, input gain and level shifting, a voltage regulator for single-supply operation, and pulse-width modulated output-current control circuitry. Inputs are compatible with most TTL, DTL, LSTTL, and low-voltage CMOS or PMOS logic.

The peak output current and hysteresis for each source/sink pair is set independently. Output current, threshold voltage, and hysteresis are set by the user's selection of external resistors. At the specified output-current trip level, the source driver turns off. The internal clamp diode then allows current to flow without additional input from the power supply. When the lower current trip point is reached, the source driver turns back on.

The UDN2962W is in a 12-pin single in-line power-tab package. The tab is at ground potential and needs no insulation. For high-current or high-frequency applications, external heat sinking may be required.

FEATURES

- 4 A Peak Output
- 45 V Min. Sustaining Voltage
- Internal Clamp Diodes
- TTL/PMOS/CMOS Compatible Inputs
- High-Speed Chopper

Always order by complete part number: **UDN2962W**.

2962 DUAL PWM SOLENOID/MOTOR DRIVER

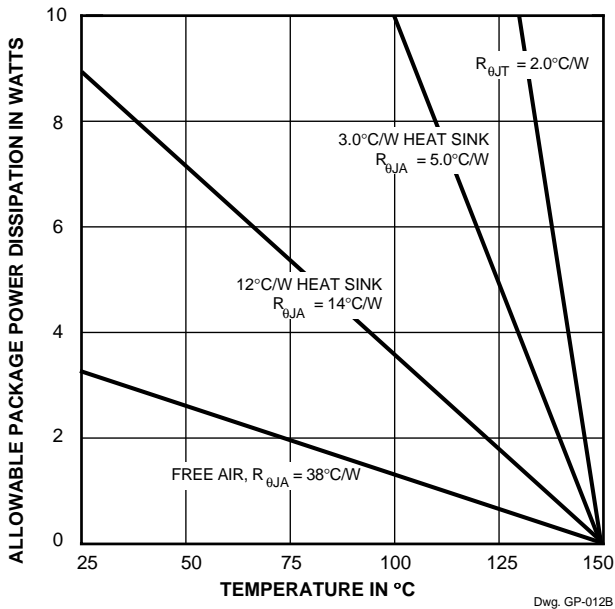
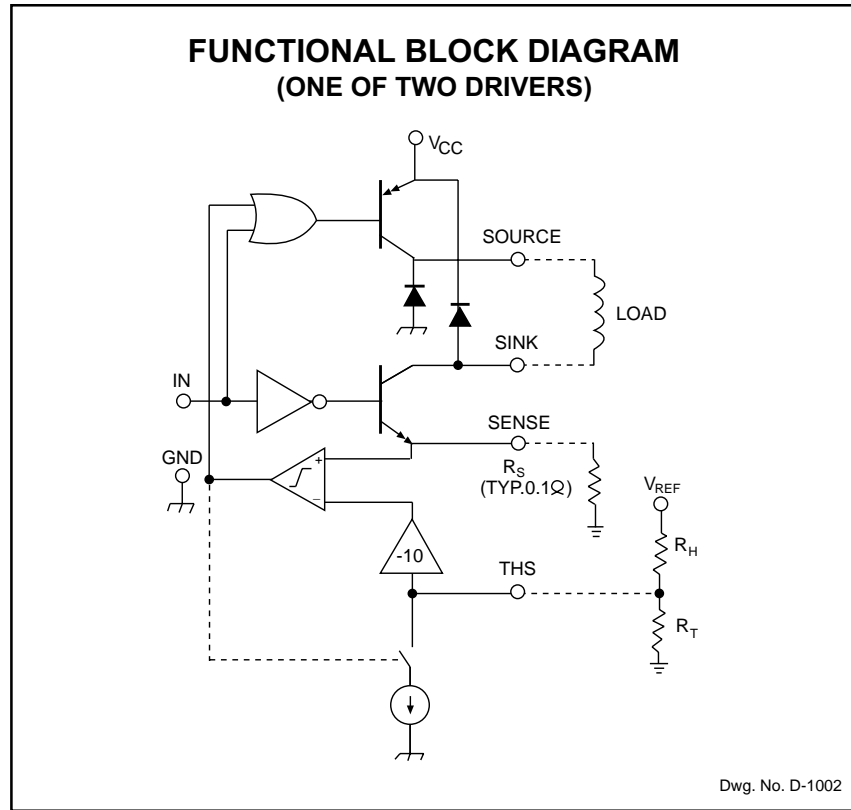

TRUTH TABLE

V_{IN}	V_{SENSE}	SOURCE DRIVER	SINK DRIVER
High	NA	Off	Off
Low	$< V_{THS}/10$	On	On
Low	$> V_{THS}/10$	Off	On

2962
DUAL PWM
SOLENOID/MOTOR DRIVER

ELECTRICAL CHARACTERISTICS at $T_A = +25^\circ\text{C}$, $T_J \leq +150^\circ\text{C}$, $V_{CC} = 45\text{ V}$, $V_{SENSE} = 0\text{ V}$ (unless otherwise noted).

Characteristic	Symbol	Test Conditions	Limits			Units
			Min.	Typ.	Max.	
Supply Voltage Range	V_{CC}	Operating	20	—	45	V

Output Drivers

Output Leakage Current	I_{CEX}	$V_{IN} = 2.4\text{ V}$, $V_{SOURCE} = 0\text{ V}$	—	<-1.0	-100	μA
		$V_{IN} = 2.4\text{ V}$, $V_{SINK} = 45\text{ V}$	—	<1.0	100	μA
Output Saturation Voltage	$V_{CE(SAT)}$	Source Drivers, $I_{LOAD} = 3.0\text{ A}$	—	2.1	2.3	V
		Source Drivers, $I_{LOAD} = 1.0\text{ A}$	—	1.7	2.0	V
		Sink Drivers, $I_{LOAD} = 3.0\text{ A}$	—	1.7	2.0	V
		Sink Drivers, $I_{LOAD} = 1.0\text{ A}$	—	1.1	1.3	V
Output Sustaining Voltage	$V_{CE(sus)}$	$I_{OUT} = \pm 3.0\text{ A}$, $L = 3.5\text{ mH}$	45	—	—	V
Output Current Regulation	ΔI_{OUT}	$V_{THS} = 0.6\text{ V to } 1.0\text{ V}$, $L = 3.5\text{ mH}$	—	—	± 25	%
		$V_{THS} = 1.0\text{ V to } 2.0\text{ V}$, $L = 3.5\text{ mH}$	—	—	± 10	%
		$V_{THS} = 2.0\text{ V to } 5.0\text{ V}$, $L = 3.5\text{ mH}$	—	—	± 5.0	%
Clamp Diode Forward Voltage	V_F	$I_F = 3.0\text{ A}$	—	1.7	2.0	V
Output Rise Time	t_r	$I_{LOAD} = 3.0\text{ A}$, 10% to 90%, Resistive Load	—	0.5	1.0	μs
Output Fall Time	t_f	$I_{LOAD} = 3.0\text{ A}$, 90% to 10%, Resistive Load	—	0.5	1.0	μs

Control Logic

Logic Input Voltage	$V_{IN(1)}$		2.4	—	—	V
	$V_{IN(0)}$		—	—	0.8	V
Logic Input Current	$I_{IN(1)}$	$V_{IN} = 2.4\text{ V}$	—	1.0	10	μA
	$I_{IN(0)}$	$V_{IN} = 0.8\text{ V}$	—	-20	-100	μA
	$I_{THS(ON)}$	$V_{THS} \geq 500\text{ mV}$, $V_{SENSE} \leq V_{THS}/10.5$	—	-2.0	—	μA
	$I_{THS(HYS)}$	$V_{SENSE} \geq V_{THS}/9.5$, $V_{THS} = 0.6\text{ V to } 5.0\text{ V}$	140	200	260	μA
V_{THS}/V_{SENSE} Ratio	—	At Trip Point, $V_{THS} = 2.0\text{ V to } 5.0\text{ V}$	9.5	10	10.5	—
Supply Current (Total Device)	I_{CC}	$V_{IN} = 2.4\text{ V}$, Outputs Off	—	8.0	12	mA
		$V_{IN} = 0.8\text{ V}$, Outputs Open	—	25	40	mA
Propagation Delay Time (Resistive Load)	t_{pd}	50% V_{IN} to 50% V_{OUT} , Turn Off	—	—	2.5	μs
		50% V_{IN} to 50% V_{OUT} , Turn On	—	—	3.0	μs
		100% V_{SENSE} to 50% V_{OUT}^*	—	—	3.0	μs

* Where $V_{SENSE} \geq V_{THS}/9.5$

NOTE: Negative current is defined as coming out of (sourcing) the specified device pin.

2962 DUAL PWM SOLENOID/MOTOR DRIVER

CIRCUIT DESCRIPTION AND APPLICATIONS INFORMATION

The UDN2962W high-current driver is intended for use as a free-running, pulse-width modulated solenoid driver.

Circuit Description. In operation, the source and sink drivers are both turned on by a low level at the input. The load current rises with time as a function of the load inductance, total circuit resistance, and supply voltage and is sensed by the external sense resistor (R_S). When the load current reaches the trip point (I_{TRIP}), the comparator output goes high and turns off the source driver. The actual load current will peak slightly higher than I_{TRIP} because of the internal logic and switching delays.

After the source driver is turned off, the load current continues to circulate through the sink driver and an internal ground clamp diode. The rate of current decay is a function of the load inductance and total circuit resistance.

An internal constant current sink reduces the trip point (hysteresis) until the decaying load current reaches the lower threshold, when the comparator output goes low and the source driver is again turned on. Load current is again allowed to rise to the trip point and the cycle repeats.

Maximum load current and hysteresis is determined by the user.

Determining Maximum Load Current and Hysteresis. Trip current (I_{TRIP}) is determined as a function of resistance R_S and the threshold voltage, V_{THS} :

$$I_{TRIP} = \frac{V_{THS}}{10 R_S}$$

where $V_{THS} = 10 \times V_{SENSE} = 0.6 \text{ V to } 5.0 \text{ V}$.

Hysteresis percentage (H) is determined by resistance R_H and is independent of the load current:

$$H = \frac{R_H}{50 \times V_{REF}}$$

The chopping frequency is asynchronous and a function of the system and circuit parameters, including load inductance, supply voltage, hysteresis setting, and switching speed of the driver.

Resistance R_T is determined as:

$$R_T = \frac{R_H V_{THS}}{V_{REF} - V_{THS}}$$

Note that if $V_{THS} = V_{REF}$, then $R_T = \infty$.

Circuit Layout. To prevent interaction between channels, each of the two high-level power ground returns (the low side of the sense resistors) must be returned independently to the low-level signal ground (pin 1). The circuit common (pin 1) can then be routed to the system ground.

The printed wiring board should utilize a heavy ground plane. For optimum performance, the driver should be soldered directly into the board.

The power supply (V_{CC}) should be decoupled with an electrolytic capacitor ($\geq 10 \mu\text{F}$) as close as possible to pin 7.

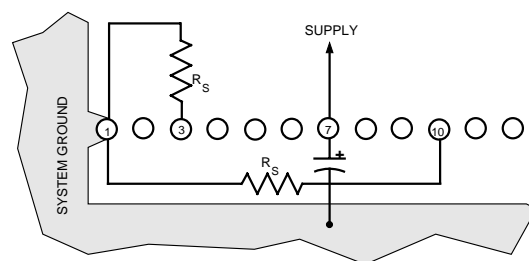

Dwg. OP-001

TYPICAL WAVESHAPES

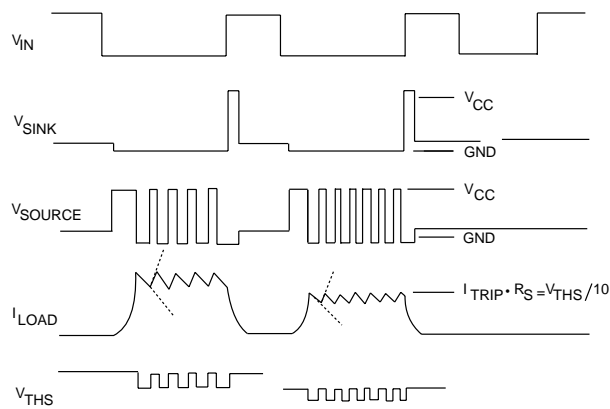

Dwg. WP-006

2962 DUAL PWM SOLENOID/MOTOR DRIVER

APPLICATIONS INFORMATION

RESISTOR R_H VALUE AS A FUNCTION OF HYSTERESIS

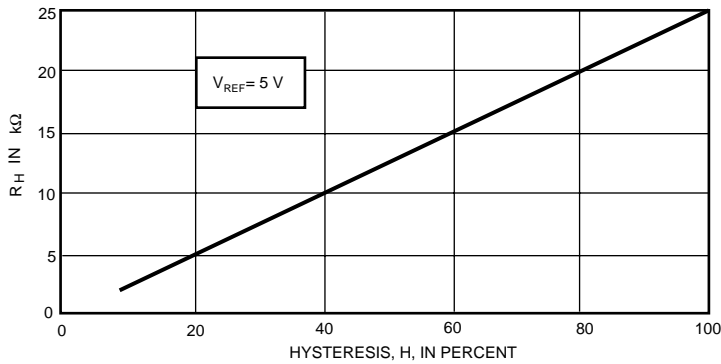

Dwg. No. A-12,417

RESISTOR R_T VALUE AS A FUNCTION OF PEAK LOAD CURRENT

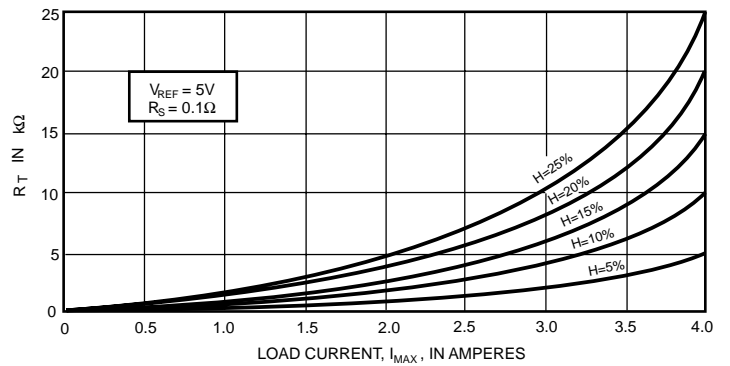

Dwg. No. A-12,416

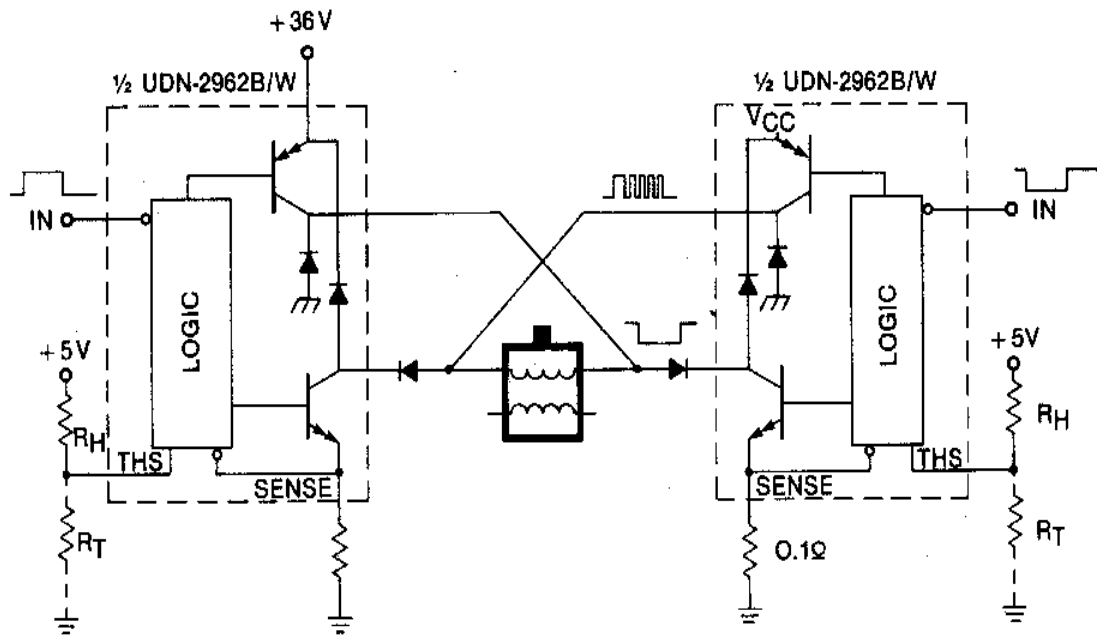

Dwg. No. D-1004

R_H AND R_T DETERMINE HYSTERESIS AND PEAK CURRENT

NOTE: Each of the drivers includes an internal logic delay to prevent potentially destructive crossover currents within the driver during phase changes. However, never simultaneously enable both inputs in the full-bridge configurations: A destructive short-circuit to ground will result.

2962
DUAL PWM
SOLENOID/MOTOR DRIVER

Dimensions in Inches
 (controlling dimensions)

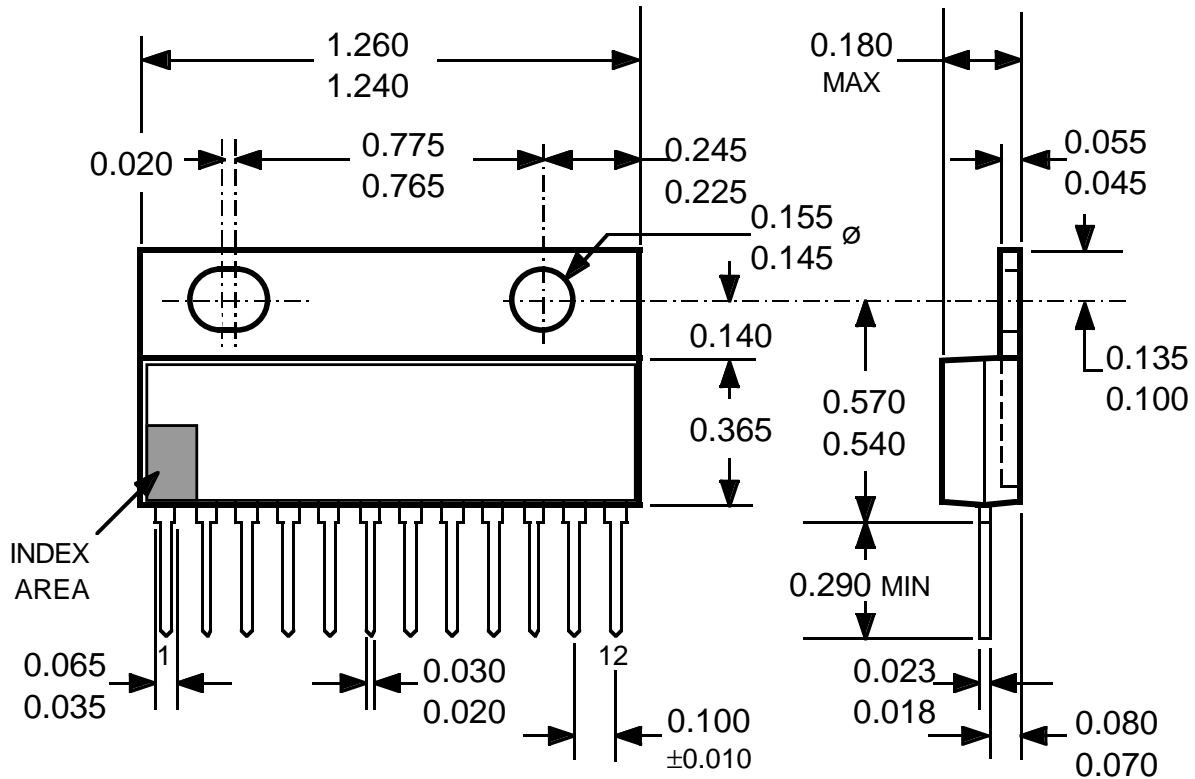

Dwg. MP-007 in

- NOTES: 1. Lead thickness is measured at seating plane or below.
 2. Lead spacing tolerance is non-cumulative.
 3. Exact body and lead configuration at vendor's option within limits shown.
 4. Lead gauge plane is 0.030" below seating plane.
 5. Supplied in standard sticks/tubes of 15 devices.

2962 DUAL PWM SOLENOID/MOTOR DRIVER

Dimensions in Millimeters

(for reference only)

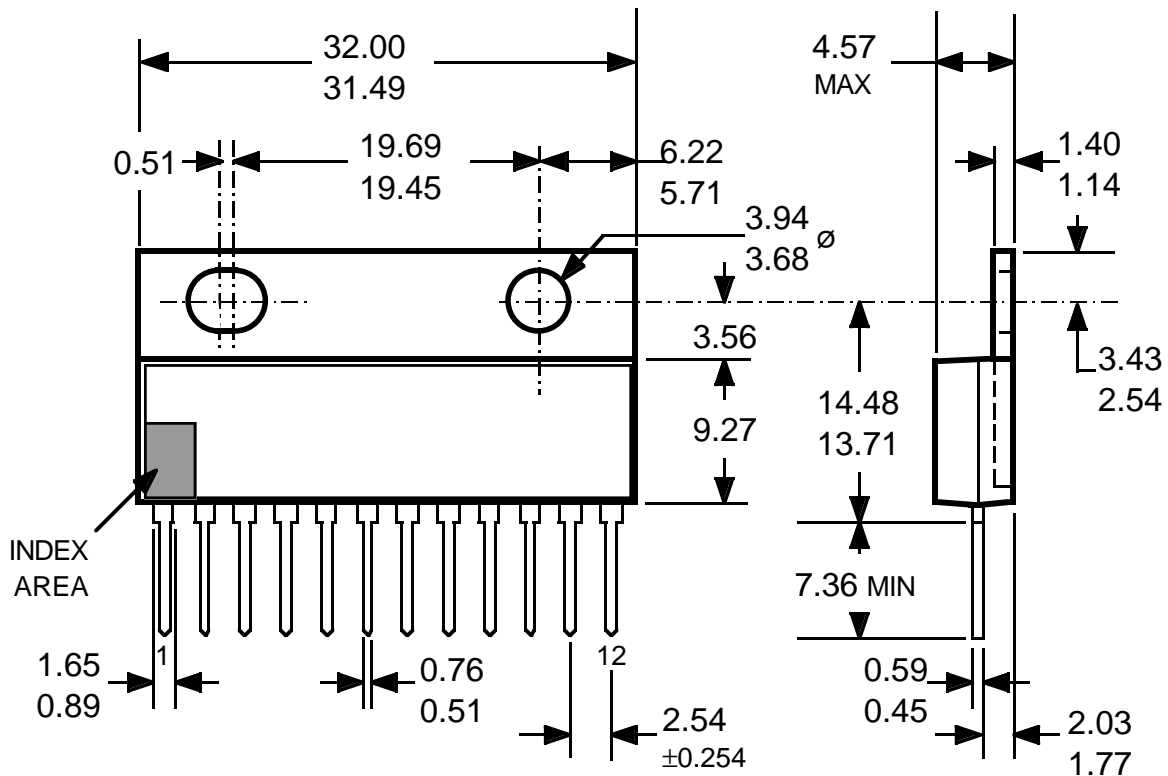

Dwg. MP-007 mm

- NOTES: 1. Lead thickness is measured at seating plane or below.
 2. Lead spacing tolerance is non-cumulative.
 3. Exact body and lead configuration at vendor's option within limits shown.
 4. Lead gauge plane is 0.762 mm below seating plane.
 5. Supplied in standard sticks/tubes of 15 devices.

The products described here are manufactured under one or more U.S. patents or U.S. patents pending.

Allegro MicroSystems, Inc. reserves the right to make, from time to time, such departures from the detail specifications as may be required to permit improvements in the performance, reliability, or manufacturability of its products. Before placing an order, the user is cautioned to verify that the information being relied upon is current.

Allegro products are not authorized for use as critical components in life-support devices or systems without express written approval.

The information included herein is believed to be accurate and reliable. However, Allegro MicroSystems, Inc. assumes no responsibility for its use; nor for any infringement of patents or other rights of third parties which may result from its use.

2962
DUAL PWM
SOLENOID/MOTOR DRIVER

MOTOR DRIVERS

Function	Output Ratings*		Part Number†
INTEGRATED CIRCUITS FOR BRUSHLESS DC MOTORS			
3-Phase Power MOSFET Controller	—	28 V	3933
3-Phase Power MOSFET Controller	—	50 V	3932
3-Phase Back-EMF Controller/Driver	±900 mA	14 V	8902-A
3-Phase Controller/Driver	±2.0 A	45 V	2936-120
INTEGRATED BRIDGE DRIVERS FOR DC AND BIPOLAR STEPPER MOTORS			
Dual Full Bridge with Protection & Diagnostics	±500 mA	30 V	3976
PWM Current-Controlled Dual Full Bridge	±650 mA	30 V	3966
PWM Current-Controlled Dual Full Bridge	±650 mA	30 V	3968
PWM Current-Controlled Dual Full Bridge	±750 mA	45 V	2916
PWM Current-Controlled Dual Full Bridge	±750 mA	45 V	2919
PWM Current-Controlled Dual Full Bridge	±750 mA	45 V	6219
PWM Current-Controlled Dual Full Bridge	±800 mA	33 V	3964
PWM Current-Controlled Dual DMOS Full Bridge	±1.0 A	35 V	3973
PWM Current-Controlled Full Bridge	±1.3 A	50 V	3953
PWM Current-Controlled Dual Full Bridge	±1.5 A	45 V	2917
PWM Current-Controlled DMOS Full Bridge	±1.5 A	50 V	3948
PWM Current-Controlled Microstepping Full Bridge	±1.5 A	50 V	3955
PWM Current-Controlled Microstepping Full Bridge	±1.5 A	50 V	3957
PWM Current-Controlled Dual DMOS Full Bridge	±1.5 A	50 V	3972
PWM Current-Controlled Dual DMOS Full Bridge	±1.5 A	50 V	3974
Dual Full-Bridge	±2.0 A	50 V	2998
PWM Full-Bridge	±2.0 A	50 V	3951
PWM Current-Controlled Full Bridge	±2.0 A	50 V	3952
PWM Current-Controlled DMOS Full Bridge	±2.0 A	50 V	3958
Dual DMOS Full Bridge	±2.5 A	50 V	3971
PWM Current-Controlled DMOS Full Bridge	±3.0 A	50 V	3959
UNIPOLAR STEPPER MOTOR & OTHER DRIVERS			
Unipolar Stepper-Motor Quad Drivers	1.0 A	46 V	7024 & 7029
Unipolar Microstepper-Motor Quad Driver	1.2 A	46 V	7042
Unipolar Stepper-Motor Translator/Driver	1.25 A	50 V	5804
Unipolar Stepper-Motor Quad Driver	1.8 A	50 V	2540
Unipolar Stepper-Motor Quad Driver	3.0 A	46 V	7026
Unipolar Microstepper-Motor Quad Driver	3.0 A	46 V	7044

* Current is maximum specified test condition, voltage is maximum rating. See specification for sustaining voltage limits or over-current protection voltage limits. Negative current is defined as coming out of (sourcing) the output.

† Complete part number includes additional characters to indicate operating temperature range and package style.

Also, see 3175, 3177, 3235, and 3275 Hall-effect sensors for use with brushless dc motors.

