

HID LAMP CONTROLLER

Check for Samples: [UCC2305-Q1](#)

FEATURES

- Qualified for Automotive Applications
- Regulates Lamp Power
- Compensates For Lamp Temperature
- Fixed Frequency Operation
- Current Mode Control
- Overcurrent Protected
- Overvoltage Shutdown
- Open and Short Protected
- High-Current FET Drive Output
- Operates Over Wide Battery Voltage Range:
5 V to 18 V

DW OR N PACKAGE (TOP VIEW)

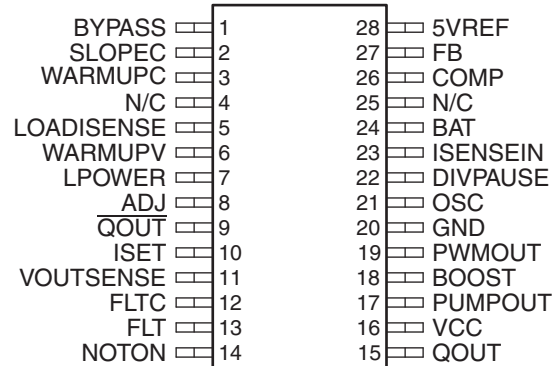

DESCRIPTION

The UCC2305 integrates all of the functions required to control and drive one HID lamp. The UCC2305 is tailored to the demanding, fast turn-on requirements of automobile headlamps, but is also applicable to all other lighting applications where HID lamps are selected. HID lamps are ideal for any lighting applications that can benefit from very high efficiency, blue-white light color, small physical lamp size, and very long life.

The UCC2305 contains a complete current mode pulse-width modulator, a lamp power regulator, lamp temperature compensation, and total fault protection. Lamp temperature compensation is critical for automobile headlamps, because without compensation, light output varies dramatically from a cold lamp to one that is fully warmed up.

The UCC2305 is tested for full performance with ambient temperature from -40°C to 105°C .

ORDERING INFORMATION

T_A	PACKAGE		ORDERABLE PART NUMBER	TOP-SIDE MARKING
-40°C to 105°C	SOIC – DW	Reel of 1000	UCC2305TDWRQ1	UCC2305T



Please be aware that an important notice concerning availability, standard warranty, and use in critical applications of Texas Instruments semiconductor products and disclaimers thereto appears at the end of this data sheet.

BLOCK DIAGRAM

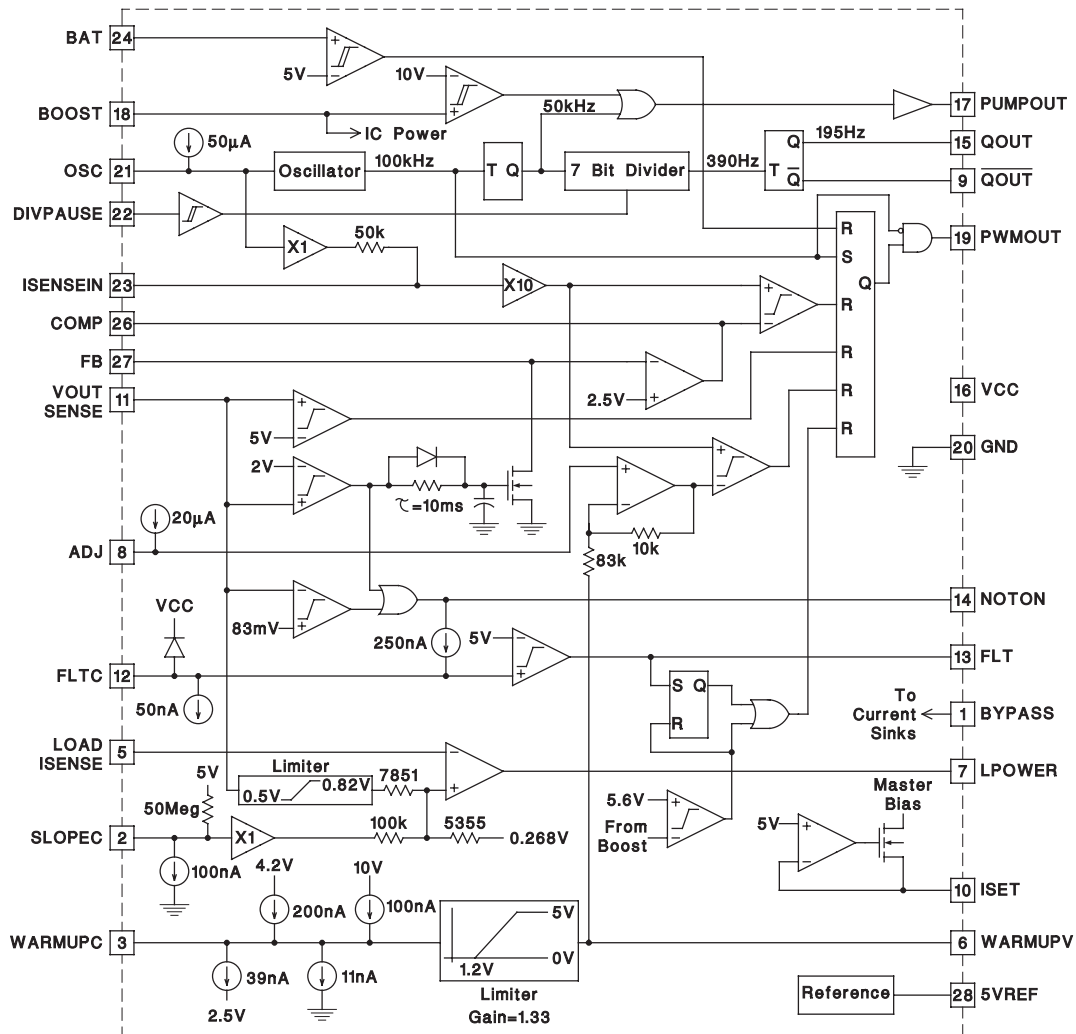

ABSOLUTE MAXIMUM RATINGS⁽¹⁾⁽²⁾

VCC supply voltage		8 V		
BOOST supply voltage		12 V		
PWMOUT current, peak		±1 A		
PWMOUT energy, capacitive load		5 µJ		
Input voltage, any input		–0.3 V to +10 V		
Output current, QOUT, \overline{QOUT} , FLT		±10 mA		
Output current, 5 VREF, LPOWER, COMP		±10 mA		
ISET current		–1 mA		
Storage temperature		–65°C to 150°C		
Junction temperature		–55°C to 150°C		
ESD	Electrostatic discharge protection	Human-Body Model (HBM) (AEC-Q100-002)	1000 V	
		Machine Model (MM) (AEC-Q100-003)	150 V	
		Charged-Device Model (CDM) (AEC-Q100-011)	Non-corner pins	500 V
			Corner pins	750 V

- (1) Stresses beyond those listed under *absolute maximum ratings* may cause permanent damage to the device. These are stress ratings only, and functional operation of the device at these or any other conditions beyond those indicated under *recommended operating conditions* is not implied. Exposure to absolute-maximum-rated conditions for extended periods may affect device reliability.
- (2) All voltages are with respect to ground.

ELECTRICAL CHARACTERISTICS

VCC = 6.6 V, ISET = 100 kΩ to GND, ADJ = 100 kΩ to GND, OSC = 200 pF to GND, BAT = 4 V, LOADISENSE connected to LPOWER, VOUTSENSE = 0.666 V, BOOST = 10.5 V, COMP connected to FB through a 100-kΩ resistor, T_A = T_J = –40°C to 105°C (unless otherwise noted)

PARAMETER	TEST CONDITIONS	MIN	TYP	MAX	UNIT
Overall Section					
VCC supply current			0.1	1	mA
BOOST supply current			3	5	mA
BOOST threshold to PUMP stop		9.1	9.6	10.2	V
BOOST threshold to PUMP start		9.2	9.7	10.3	V
BOOST threshold to PWMOUT		4.7	5.4	6.1	V
Battery Section					
BAT threshold to PWMOUT stop		4.7	5	5.3	Vs
BAT threshold to PWMOUT start		4.15	4.8	5	V
BAT input current	BAT = 4 V	–1		1	µA
Oscillator and Divider Section					
OSC frequency		80	100	120	kHz
OSC pullup current		–70	–50	–40	µA
DIVPAUSE threshold to pause		1.1	1.5	1.9	V
DIVPAUSE threshold to divide		0.8	1.2	1.6	V
DIVPAUSE input current	0 V < DIVPAUSE < 6 V	–8	–5	–1	µA
Reference Section					
5 VREF voltage		4.83	5	5.15	V
ISET voltage		4.8	4.8	5.2	V

ELECTRICAL CHARACTERISTICS (continued)

VCC = 6.6 V, ISET = 100 kΩ to GND, ADJ = 100 kΩ to GND, OSC = 200 pF to GND, BAT = 4 V, LOADISENSE connected to LPOWER, VOUTSENSE = 0.666 V, BOOST = 10.5 V, COMP connected to FB through a 100-kΩ resistor, T_A = T_J = -40°C to 105°C (unless otherwise noted)

PARAMETER	TEST CONDITIONS	MIN	TYP	MAX	UNIT
Error Amplifier Section					
FB voltage		2.4	2.5	2.6	V
FB input current		-1	0	1	μA
FB sink current	VOUTSENSE = 4 V, FB = 4 V	0.3	1.5		mA
FB release delay	VOUTSENSE Step from 4 V to 1 V	14.5	30	43	ms
COMP source current	FB = 2 V, COMP = 4 V		-3	-0.2	mA
COMP sink current	FB = 3 V, COMP = 1 V	0.2	1		mA
Load Power Amplifier Section					
LOADISENSE input current		-2.5	-0.1	2.5	μA
LPOWER source current	LPOWER = 0 V		-8	-0.1	mA
LPOWER sink current	LPOWER = 1 V	0.1	1.3		mA
LPOWER voltage	VOUTSENSE = 0 V	0.32	0.40	0.48	V
	VOUTSENSE = 0.45 V	0.32	0.40	0.48	V
	VOUTSENSE = 0.65 V	0.41	0.46	0.51	V
	VOUTSENSE = 0.88 V	0.43	0.51	0.59	V
	VOUTSENSE = 2 V	0.43	0.51	0.59	V
	VOUTSENSE = 0.7 V, SLOPEC = 0 V	0.29	0.34	0.41	V
Input Current Sense Section					
ISENSEIN threshold	COMP = 5 V, WARMUPC = 0 V	0.16	0.21	0.28	V
	COMP = 5 V, WARMUPC = 10 V	0.10	0.19	0.27	
	COMP = 1 V, WARMUPC = 0 V	0.07	0.10	0.20	
ISENSEIN bias current	OSC = 0 V	-15	-5	-2	μA
	OSC = 2 V	-105	-40	-15	
VOUTSENSE Section					
VOUTSENSE threshold to PWMOUT		4.2	5	5.2	V
VOUTSENSE threshold to FB		1.7	1.9	2.1	V
VOUTSENSE threshold to NOTON		0.035	0.083	0.140	V
VOUTSENSE input current		-1		1	μA
Outputs Section					
PWMOUT high voltage	I _{PWMOUT} = -100 mA	9.15	10		V
PWMOUT low voltage	I _{PWMOUT} = 100 mA		0.3	0.6	V
PUMPOUT high voltage	I _{PUMPOUT} = -10 mA	5.3	5.8		V
PUMPOUT low voltage	I _{PUMPOUT} = 10 mA		1	1.8	V
PUMPOUT frequency	BOOST = 9.5 V	35	50	60	kHz
NOTON high voltage	I _{NOTON} = -1 mA	5	6.3		V
NOTON low voltage	I _{NOTON} = 1 mA		0.1	0.3	V
QOUT, \overline{QOUT} high voltage	I _{QOUT} = -1 mA or I _{\overline{QOUT}} = -1 mA	5	6.3		V
QOUT, \overline{QOUT} low voltage	I _{QOUT} = 1 mA or I _{\overline{QOUT}} = 1 mA		0.1	0.45	V
QOUT, \overline{QOUT} frequency		150	200	250	Hz
FLT high voltage	I _{FLT} = -1 mA	6	6.3		V
FLT low voltage	I _{FLT} = 1 mA		0.1	0.3	V

ELECTRICAL CHARACTERISTICS (continued)

VCC = 6.6 V, ISET = 100 kΩ to GND, ADJ = 100 kΩ to GND, OSC = 200 pF to GND, BAT = 4 V, LOADISENSE connected to LPOWER, VOUTSENSE = 0.666 V, BOOST = 10.5 V, COMP connected to FB through a 100-kΩ resistor, T_A = T_J = -40°C to 105°C (unless otherwise noted)

PARAMETER	TEST CONDITIONS	MIN	TYP	MAX	UNIT
Timing Capacitor Section					
FLTC discharge current	FLTC = 2.5 V	35	60	103	nA
FLTC charge current	FLTC = 2.5 V	-430	-300	-220	nA
FLTC threshold to FAULT		4.65	4.9	5.1	V
SLOPEC charge current	SLOPEC = 0.5 V	-165	-90	-60	nA
	SLOPEC = 2.2 V	-105	-60	-40	
	SLOPEC = 4.2 V	-50	-30	-10	
SLOPEC voltage	I _{SLOPEC} = -125 nA	1.3	1.5	1.7	V
	I _{SLOPEC} = -50 nA	2.8	3	3.2	
SLOPEC discharge current	SLOPEC = 2.2 V, VCC = 0 V, BOOST = 0 V, BYPASS = 8 V	40	100	200	nA
WARMUPC charge current	WARMUPC = 0 V	-525	-375	-275	nA
	WARMUPC = 2 V	-525	-375	-300	
	WARMUPC = 6 V	-200	-120	-75	
WARMUPC voltage, charging	I _{WARMUPC} = -250 nA	3.39	3.8	4.1	V
WARMUPC discharge current	WARMUPC = 5 V, VCC = 0 V, BOOST = 0 V, BYPASS = 8 V	23	50	126	nA
	WARMUPC = 1V, VCC = 0 V, BOOST = 0 V, BYPASS = 8 V	5	10	38	
WARMUPC voltage, discharging	I _{WARMUPC} = 25 nA, VCC = 0 V, BOOST = 0 V, BYPASS = 8 V	1.5	1.9	2.3	V
ADJ bias current	VADJ = 0 V	-38	-20	-12	μA
WARMUPV voltage	WARMUPC = 1 V	0.05	0.125	0.29	V
	WARMUPC = 2 V	0.9	1	1.5	
	WARMUPC = 3 V	2.3	2.48	2.66	
	WARMUPC = 5 V	4.5	4.8	5.25	
	WARMUPC = 10 V	4.5	4.8	5.25	
BYPASS voltage	VCC = 0 V	8.8	9.6		V
BYPASS current	VCC = 0 V, BOOST = 0 V, BYPASS = 8 V		2.5	7	μA

Pin Descriptions

5 VREF: Circuitry in the UCC2305 uses the internal 5 V reference to set currents and thresholds. This reference can also be used for other functions if required.

ADJ: The ratio of cold lamp peak current to warmed-up lamp peak current is controlled by the voltage on ADJ. To select this voltage, connect a resistor from ADJ to GND.

BAT: This input is used to detect excessively high input voltage and shut down the IC if the input exceeds a predetermined level. Connect BAT to a voltage divider across the input supply. The UCC2305 shuts down when this input voltage exceeds 5 V. To protect the IC in the event of very high or negative inputs, keep divider impedance higher than 10k.

BOOST: Although the UCC2305 is powered from the VCC input, most functions of the device operate from a supply voltage of approximately 10 V connected to BOOST. This 10 V supply can be generated by a voltage doubler using PUMPOUT as an AC signal and external diodes as switches.

BYPASS: The UCC2305 compensates for lamp temperature changes by changing the voltage on the SLOPEC and WARMUPC capacitors. These voltages rise as the lamp warms up. An internal calculation determines what power should be applied to the lamp.

When the HID lamp is turned off, power to the lamp and the controller is removed, leaving these two critical capacitors charged to specific voltages. Also, with power off, the lamp will cool down at a controlled rate. It is essential that the two capacitors discharge at a similarly controlled rate so that if the lamp is restarted before the lamp is fully cooled, the controller will have an estimate of new lamp temperature, and can again command the correct power for the lamp. Power to control the discharge of these capacitors comes from energy stored in a large capacitor connected to BYPASS. The value of the capacitor required can be estimated assuming a maximum BYPASS current of 5 μ A, a discharge time of 60 s, and a maximum allowable droop of 5 V by [Equation 1](#):

$$C = I \times \frac{\Delta t}{\Delta V} = 5\mu\text{A} \times \frac{60\text{s}}{5\text{V}} = 60\mu\text{F} \quad (1)$$

COMP: Differences between commanded lamp power and desired lamp power are amplified by an error amplifier. This amplifier senses the difference between the voltage at FB and 2.5 V, and drives COMP with an amplified error voltage. A capacitor is normally connected from COMP to FB to compensate the overall feedback loop so that the system will be stable.

DIVPAUSE: The QOUT and $\overline{\text{QOUT}}$ outputs can be used to switch lamp polarity in an AC ballast. It is important to stop polarity switching when the lamp is being lit, so that the arc across the electrodes can form in the correct place. Pulling high on DIVPAUSE stops the internal divider which generates the QOUT and $\overline{\text{QOUT}}$ signals, and thereby freezes the QOUT and $\overline{\text{QOUT}}$ signals.

To stop the divider when the lamp is being lit and start after the lamp has lit, connect a resistor from NOTON to DIVPAUSE and a capacitor from DIVPAUSE to GND.

FLTC: The voltage on VOUTSENSE is proportional to lamp voltage. If that voltage is too high or too low, the lamp is either open, shorted, or not yet running. During normal operation, there is a capacitor connected to FLTC, and this capacitor is discharged to 0 V by a current source inside the UCC2305.

The UCC2305 monitors the voltage on VOUTSENSE and compares it to an internal 83mV lower threshold and a 2 V upper threshold. If the voltage is outside this window, then the IC will pull up on FLTC with a current of approximately 250 nA. If the fault remains long enough to charge the external FLTC capacitor over 5 V, the controller declares a catastrophic fault and shuts the IC down. The IC will stay shut down until power is removed from BOOST.

If the fault clears before the FLTC capacitor reaches 5 V, the capacitor discharges down to 0 V. This discharge current is approximately 50 nA, representing a five times longer discharge rate than charge rate.

FLT: If the voltage on the FLTC pin exceeds 5 V, indicating a severe fault, then a latch in the UCC2305 sets and PWM drive is halted. In addition, the FLT output goes high to VCC, indicating a serious system fault.

FB: Differences between commanded lamp power and desired lamp power are amplified by an error amplifier. This amplifier senses the difference between the voltage at FB and 2.5 V, and drives COMP with an amplified error voltage.

GND: Ground for all functions is through this pin.

ISENSEIN: The power regulating algorithm in the UCC2305 HID Controller computes a function of lamp current and lamp voltage and commands the appropriate battery current to keep lamp power constant. This appropriate battery current is sensed by a connection from I-SENSEIN to a current sense resistor. This current sensed pulse width modulation scheme is often referred to as current mode control.

In addition to this current regulation, the UCC2305 contains peak input current limiting. This limiting is set to 0.2 V across the ISENSEIN resistor during normal operation and 0.4 V during starting. The transition from starting to normal operation is accomplished by the rise of the WARMUPC capacitor.

Current mode control has an advantage over voltage mode control in that a current mode loop is easier to compensate. Current mode control has a disadvantage compared to voltage mode control in that the loop can enter into chaotic oscillations at high duty cycles. These chaotic oscillations can be prevented using slope compensation. The UCC2305 contains internal slope compensation in the form of a current proportional to OSC voltage on ISENSEIN. This current combined with an external resistor from ISENSEIN to the current sense resistor creates a voltage drop proportional to OSC voltage, which gives slope compensation.

ISET: Many functions inside the UCC2305 require precise currents to give well controlled performance. These controlled currents are programmed by a resistor from ISET to GND. A resistor of 100k programs the IC to normal operating current. Lower resistor values increase the internal currents. Some of the functions which are influenced by this resistor are WARMUPC charging and discharging, SLOPEC charging and discharging, FLTC charging and discharging, and error amplifier bandwidth

LOADISENSE: Just as ISENSEIN is normally connected to a current sense resistor which monitors battery current, LOADISENSE is normally connected to a resistor which monitors lamp current. Lamp current is then regulated by the controller such that the correct lamp power is supplied at every lamp temperature, in conjunction with the lamp voltage sensed by VOUTSENSE.

LPOWER: LOADISENSE directly drives one input of an op amp in the UCC2305. This amplifier amplifies the difference between the desired load current and the actual load current, and generates an output signal on LPOWER which feeds the error amplifier.

NOTON: While the lamp is in a fault condition, such as excessively high or low lamp voltage, NOTON is pulled high to VCC, indicating that the arc is not yet correct. When the voltage on VOUTSENSE is within the 83 mV to 2 V window, NOTON is pulled low.

OSC: The fixed frequency PWM in the UCC2305 operates at the frequency programmed by the OSC pin. Typically, a 200 pF capacitor from OSC to GND programs the PWM frequency at 100 kHz. In addition, this programs the charge pump at 50 kHz and the QOUT and $\overline{\text{QOUT}}$ signals at 192 Hz. The actual oscillator frequency is a function of both the capacitor from OSC to GND and the resistor from ISET to GND.

PUMPOUT: Although the UCC2305 is powered from the VCC input, most functions of the device operate from a supply voltage of approximately 10 V connected to BOOST. In normal operation, this 10 V supply is generated by a voltage doubler using the PUMPOUT pin as an AC signal and external diodes as switches. PUMP-OUT is a square wave which swings from VCC to GND at half of the OSC frequency.

PWMOUT: The output of the pulse width modulator is a command signal to a power MOSFET switch. This signal appears on PWMOUT. In normal systems, PWM-OUT can be directly connected to the gate of an N-channel power MOSFET such as the IRF540. If the lead between the UCC2305 and the MOSFET is longer than a few cm, a 10 ohm resistor from PWMOUT to gate may be required to dampen overshoot and undershoot.

$\overline{\text{QOUT}}$: The UCC2305 is immediately configured for DC HID lamps. To operate with AC HID lamps, it is necessary to add a power H-bridge which will toggle lamp voltage. A practical switching frequency for this toggle function is the OSC frequency divided by 512, or 192 Hz for a 100 kHz oscillator.

The $\overline{\text{QOUT}}$ pin is a logic output which toggles at the OSC frequency divided by 512, 180 degrees out of phase with the QOUT pin.

QOUT: The QOUT pin is a logic output which toggles at the OSC frequency divided by 512, 180 degrees out of phase with the $\overline{\text{QOUT}}$ pin.

SLOPEC: To track lamp warm-up and cool down, two capacitors connected to the UCC2305 charge and discharge. One is connected to SLOPEC. The other is connected to WARMUPC. The capacitor connected to SLOPEC charges up to 5 V with a rate controlled by the resistor from ISET to GND. With a nominal 100k ISET resistor the charging current into SLOPEC is equivalent to the current from a 50Meg resistor to 5 V.

When power is removed from VCC, SLOPEC discharges at a constant current, nominally 100 nA.

APPLICATION INFORMATION

Typical Application

This circuit shows the UCC2305 HID Lamp Controller IC in a flyback converter. The output of the converter is regulated at constant power, so that lamp intensity is relatively constant regardless of small lamp manufacturing variations.

Full Bridge Output Stage

The output of the flyback converter is directed to the AC lamp through a full bridge inverter. The full bridge is switched at a low frequency (typically 195 Hz), so that the average lamp voltage is zero. The low frequency switching is derived from the PWM oscillator. It is desirable to switch lamp polarity when running, but switching lamp polarity can interfere with clean starting. The UCC2305 has a logic output called NOTON which is high when the lamp is not running (Not On) and low when the lamp is running. This output is connected to the DIVPAUSE input so that the low frequency switching stops until the lamp is fully lit.

The UCC2305 HID Controller IC has two low frequency outputs, QOUT and $\overline{\text{QOUT}}$. These outputs are capable of driving low-side MOSFETs directly at 195 Hz, but high-side MOSFETs require a level-shifted drive. This can be as simple as a high voltage transistor and a resistor pull-up, combined with the correct choice of phases.

Regulated Lamp Input Power Gives Constant Intensity

The LPOWER output of the UCC2305 is a voltage roughly proportional to lamp input power. The UCC2305 regulates constant lamp power over a wide range of lamp voltages. The range of lamp voltages which produce constant lamp power is set by the limiting amplifier on VOUTSENSE.

For inputs to VOUTSENSE below 0.5 V, such as would occur with a shorted lamp, the loop regulates constant load current. For inputs to VOUTSENSE greater than 0.82 V, as might occur with a lamp that is open or not yet lit, the loop also regulates constant load current, but at a lower current than for a shorted lamp. In between those two voltages, the amplifier driving the LPOWER pin will sum the load current and load voltage and produce a signal roughly proportional to load power. The summing amplifier approximates power well enough to hold power within $\pm 10\%$ over a factor of two in lamp voltage.

The UCC2305 HID Controller contains a current mode PWM similar to the industry standard UC3842 and UCC3802 circuits. This controller uses a high gain op amp to regulate the output of the LPOWER circuit. This op amp drives a high speed PWM comparator, which compares converter input current to the output of the op amp and uses this signal to set duty cycle.

Slope Compensation

In addition to a complete current mode PWM, the UCC2305 HID Controller contains internal slope compensation, a valuable function which improves current loop stability for high duty cycles. Slope compensation is accomplished with an on-chip current ramp and an off-chip resistor RSL. Larger values of RSL give more slope compensation and a more stable feedback loop.

Powering The UCC2305

Conventional power MOSFETs require at least 8 V of gate drive to ensure high efficiency and low on resistance. Despite this requirement, the UCC2305 HID Controller can be used to build a ballast that will drive power MOSFETs well with input supplies as low as 5 V. The UCC2305 does this using a charge pump.

In this typical application, power for the UCC2305 HID Controller IC is derived from a 6.8 V zener supply. This zener regulated supply gives the application overvoltage protection, reverse battery protection, low parts count, and low cost. The output of the 6.8 V zener supply drives the VCC pin of the UCC2305. VCC is the input to the UCC2305 charge pump. The charge pump generates a regulated 10 V supply on the BOOST output. This 10 V supply drives all other functions on the UCC2305.

Protection From Over Voltage

The most significant stresses in an automotive environment are the overvoltage conditions which can occur during load dump and double-battery jump start. At these times, the voltage into the ballast can go so high that even the most overdesigned power stage will be damaged. The UCC2305 is inherently immune to damage from this when operated with a zener regulated supply. In addition, the UCC2305 will protect the ballast components by shutting down the PWM in the presence of excessive voltage on the BAT input.

This typical application shows a voltage divider consisting of a 270k resistor and a 100k resistor driving the BAT input. The threshold of the BAT input is approximately 5 V, so this divider sets the shutdown voltage at approximately 18.5 V.

Programming the UCC2305

All circuitry on the UCC2305 HID Lamp Controller is operated from a bias current set by the resistor from ISET to ground. For best operation, this resistor (R_{SET}) should be between 75k and 150k.

Oscillator Frequency

The UCC2305 HID Lamp Controller PWM oscillator is set by the resistor from ISET to ground and by the capacitor from OSC to ground. Oscillator frequency can be estimated by [Equation 2](#):

$$f_{OSC} = \frac{2}{R_{SET} \times C_{OSC}} \quad (2)$$

For operation at 100 kHz, R_{SET} should be 100k and C_{OSC} should be 200 pF.

The PWM oscillator also determines the low frequency lamp switching rate for AC lamps. The exact lamp switching rate is the PWM frequency divided by 512.

Lamp Temperature Compensation

Automobile headlights must come up to full intensity very quickly, but HID lamps require many minutes to stabilize. The UCC2305 HID Controller contains sophisticated internal circuitry to anticipate lamp temperature and also to compensate for lamp temperature.

The circuits anticipate lamp temperature by monitoring charge on capacitors which charge when the lamp is on and discharge when the lamp is off. The UCC2305 HID Controller compensates for lamp temperature by driving the lamp with a higher lamp power when the lamp is cold and reducing the power to a normal operating level when the lamp is warmed up. The capacitors which set these time constants are external film capacitors C_S and C_W , and are connected to SLOPEC and WARMUPC. C_S and C_W are critical capacitors and must be selected to match the time-temperature relationship of the lamp.

In addition to changing the power regulation point, the WARMUPC capacitor voltage also changes the short circuit lamp current. The ratio of cold short circuit current to warmed-up short circuit current is set by the resistor from ADJ to ground.

When power is removed from the ballast, C_S and C_W must discharge at a controlled rate. The discharge currents are programmed by current sources on the UCC2305 HID Controller. These current sources are powered by the power supply connected to BYPASS. In a typical application, a non-critical electrolytic capacitor from BYPASS to ground stores energy when the ballast is on and uses this energy to control the discharge rate when the ballast is off.

Flyback HID Ballast

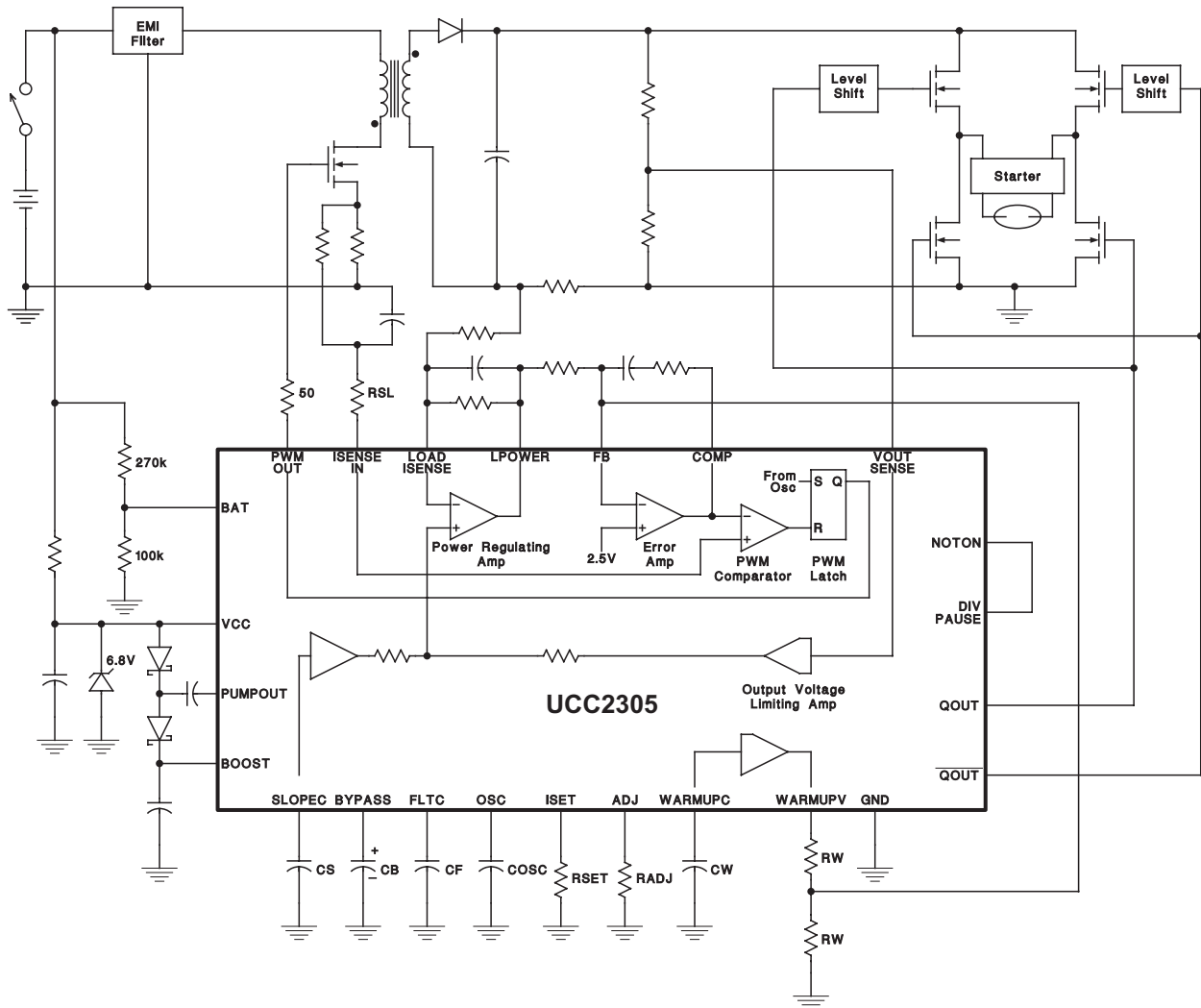

Figure 1. Flyback HID Ballast

PACKAGING INFORMATION

Orderable Device	Status (1)	Package Type	Package Drawing	Pins	Package Qty	Eco Plan (2)	Lead/Ball Finish (6)	MSL Peak Temp (3)	Op Temp (°C)	Device Marking (4/5)	Samples
UCC2305TDWRQ1	ACTIVE	SOIC	DW	28	1000	Green (RoHS & no Sb/Br)	CU NIPDAU-DCC	Level-2-260C-1 YEAR	-40 to 105	UCC2305T	Samples

(1) The marketing status values are defined as follows:

ACTIVE: Product device recommended for new designs.

LIFEBUY: TI has announced that the device will be discontinued, and a lifetime-buy period is in effect.

NRND: Not recommended for new designs. Device is in production to support existing customers, but TI does not recommend using this part in a new design.

PREVIEW: Device has been announced but is not in production. Samples may or may not be available.

OBSELETE: TI has discontinued the production of the device.

(2) Eco Plan - The planned eco-friendly classification: Pb-Free (RoHS), Pb-Free (RoHS Exempt), or Green (RoHS & no Sb/Br) - please check <http://www.ti.com/productcontent> for the latest availability information and additional product content details.

TBD: The Pb-Free/Green conversion plan has not been defined.

Pb-Free (RoHS): TI's terms "Lead-Free" or "Pb-Free" mean semiconductor products that are compatible with the current RoHS requirements for all 6 substances, including the requirement that lead not exceed 0.1% by weight in homogeneous materials. Where designed to be soldered at high temperatures, TI Pb-Free products are suitable for use in specified lead-free processes.

Pb-Free (RoHS Exempt): This component has a RoHS exemption for either 1) lead-based flip-chip solder bumps used between the die and package, or 2) lead-based die adhesive used between the die and leadframe. The component is otherwise considered Pb-Free (RoHS compatible) as defined above.

Green (RoHS & no Sb/Br): TI defines "Green" to mean Pb-Free (RoHS compatible), and free of Bromine (Br) and Antimony (Sb) based flame retardants (Br or Sb do not exceed 0.1% by weight in homogeneous material)

(3) MSL, Peak Temp. - The Moisture Sensitivity Level rating according to the JEDEC industry standard classifications, and peak solder temperature.

(4) There may be additional marking, which relates to the logo, the lot trace code information, or the environmental category on the device.

(5) Multiple Device Markings will be inside parentheses. Only one Device Marking contained in parentheses and separated by a "~" will appear on a device. If a line is indented then it is a continuation of the previous line and the two combined represent the entire Device Marking for that device.

(6) Lead/Ball Finish - Orderable Devices may have multiple material finish options. Finish options are separated by a vertical ruled line. Lead/Ball Finish values may wrap to two lines if the finish value exceeds the maximum column width.

Important Information and Disclaimer:The information provided on this page represents TI's knowledge and belief as of the date that it is provided. TI bases its knowledge and belief on information provided by third parties, and makes no representation or warranty as to the accuracy of such information. Efforts are underway to better integrate information from third parties. TI has taken and continues to take reasonable steps to provide representative and accurate information but may not have conducted destructive testing or chemical analysis on incoming materials and chemicals. TI and TI suppliers consider certain information to be proprietary, and thus CAS numbers and other limited information may not be available for release.

In no event shall TI's liability arising out of such information exceed the total purchase price of the TI part(s) at issue in this document sold by TI to Customer on an annual basis.

OTHER QUALIFIED VERSIONS OF UCC2305-Q1 :

- Catalog: [UCC2305](#)

NOTE: Qualified Version Definitions:

- Catalog - TI's standard catalog product

TAPE AND REEL INFORMATION



QUADRANT ASSIGNMENTS FOR PIN 1 ORIENTATION IN TAPE



*All dimensions are nominal

Device	Package Type	Package Drawing	Pins	SPQ	Reel Diameter (mm)	Reel Width W1 (mm)	A0 (mm)	B0 (mm)	K0 (mm)	P1 (mm)	W (mm)	Pin1 Quadrant
UCC2305TDWRQ1	SOIC	DW	28	1000	330.0	32.4	11.35	18.67	3.1	16.0	32.0	Q1

TAPE AND REEL BOX DIMENSIONS

*All dimensions are nominal

Device	Package Type	Package Drawing	Pins	SPQ	Length (mm)	Width (mm)	Height (mm)
UCC2305TDWRQ1	SOIC	DW	28	1000	367.0	367.0	55.0

DW (R-PDSO-G28)

PLASTIC SMALL OUTLINE

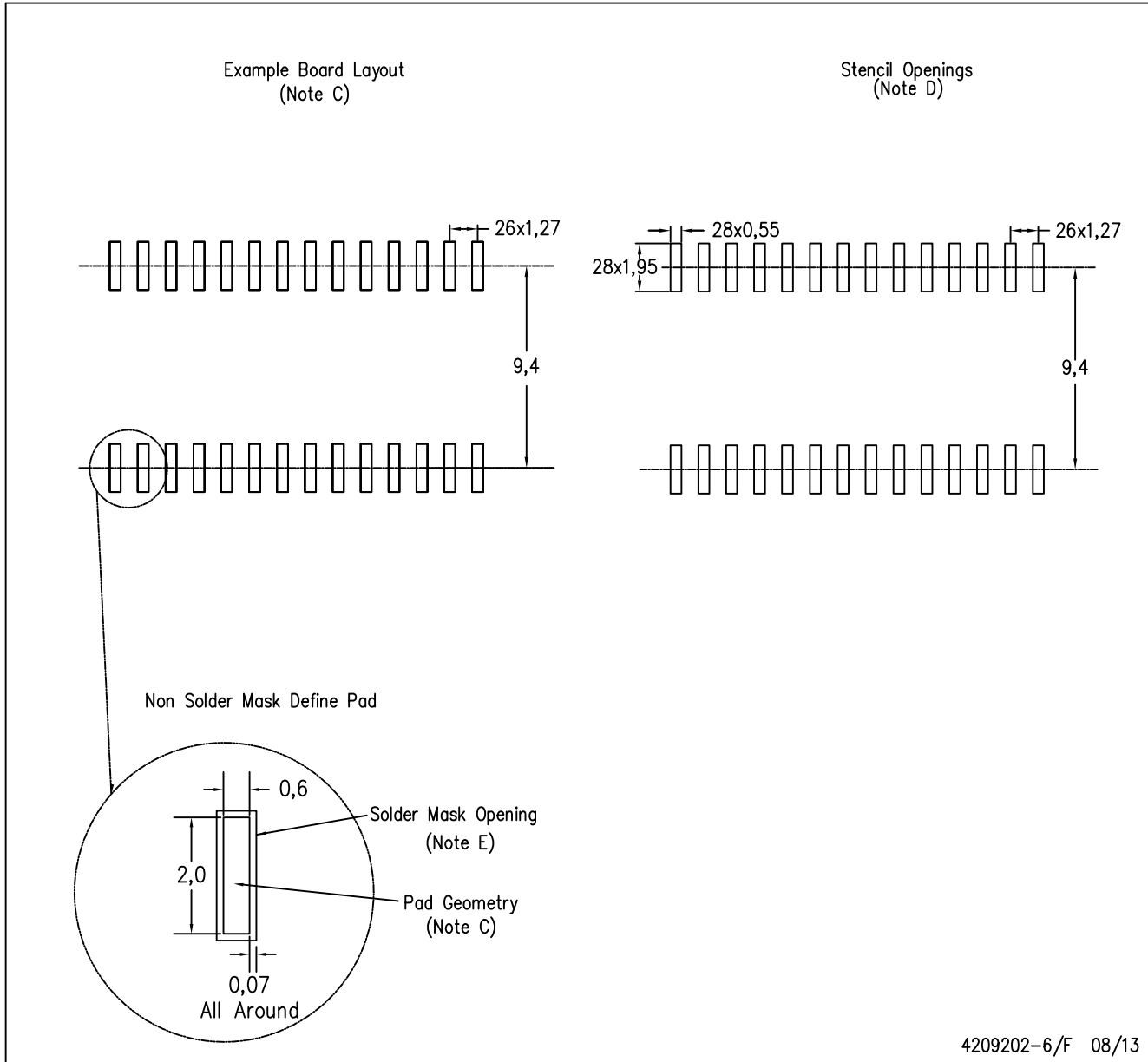

4209202-6/F 08/13

- NOTES:
- A. All linear dimensions are in millimeters.
 - B. This drawing is subject to change without notice.
 - C. Refer to IPC7351 for alternate board design.
 - D. Laser cutting apertures with trapezoidal walls and also rounding corners will offer better paste release. Customers should contact their board assembly site for stencil design recommendations. Refer to IPC-7525
 - E. Customers should contact their board fabrication site for solder mask tolerances between and around signal pads.

IMPORTANT NOTICE

Texas Instruments Incorporated and its subsidiaries (TI) reserve the right to make corrections, enhancements, improvements and other changes to its semiconductor products and services per JESD46, latest issue, and to discontinue any product or service per JESD48, latest issue. Buyers should obtain the latest relevant information before placing orders and should verify that such information is current and complete. All semiconductor products (also referred to herein as "components") are sold subject to TI's terms and conditions of sale supplied at the time of order acknowledgment.

TI warrants performance of its components to the specifications applicable at the time of sale, in accordance with the warranty in TI's terms and conditions of sale of semiconductor products. Testing and other quality control techniques are used to the extent TI deems necessary to support this warranty. Except where mandated by applicable law, testing of all parameters of each component is not necessarily performed.

TI assumes no liability for applications assistance or the design of Buyers' products. Buyers are responsible for their products and applications using TI components. To minimize the risks associated with Buyers' products and applications, Buyers should provide adequate design and operating safeguards.

TI does not warrant or represent that any license, either express or implied, is granted under any patent right, copyright, mask work right, or other intellectual property right relating to any combination, machine, or process in which TI components or services are used. Information published by TI regarding third-party products or services does not constitute a license to use such products or services or a warranty or endorsement thereof. Use of such information may require a license from a third party under the patents or other intellectual property of the third party, or a license from TI under the patents or other intellectual property of TI.

Reproduction of significant portions of TI information in TI data books or data sheets is permissible only if reproduction is without alteration and is accompanied by all associated warranties, conditions, limitations, and notices. TI is not responsible or liable for such altered documentation. Information of third parties may be subject to additional restrictions.

Resale of TI components or services with statements different from or beyond the parameters stated by TI for that component or service voids all express and any implied warranties for the associated TI component or service and is an unfair and deceptive business practice. TI is not responsible or liable for any such statements.

Buyer acknowledges and agrees that it is solely responsible for compliance with all legal, regulatory and safety-related requirements concerning its products, and any use of TI components in its applications, notwithstanding any applications-related information or support that may be provided by TI. Buyer represents and agrees that it has all the necessary expertise to create and implement safeguards which anticipate dangerous consequences of failures, monitor failures and their consequences, lessen the likelihood of failures that might cause harm and take appropriate remedial actions. Buyer will fully indemnify TI and its representatives against any damages arising out of the use of any TI components in safety-critical applications.

In some cases, TI components may be promoted specifically to facilitate safety-related applications. With such components, TI's goal is to help enable customers to design and create their own end-product solutions that meet applicable functional safety standards and requirements. Nonetheless, such components are subject to these terms.

No TI components are authorized for use in FDA Class III (or similar life-critical medical equipment) unless authorized officers of the parties have executed a special agreement specifically governing such use.

Only those TI components which TI has specifically designated as military grade or "enhanced plastic" are designed and intended for use in military/aerospace applications or environments. Buyer acknowledges and agrees that any military or aerospace use of TI components which have **not** been so designated is solely at the Buyer's risk, and that Buyer is solely responsible for compliance with all legal and regulatory requirements in connection with such use.

TI has specifically designated certain components as meeting ISO/TS16949 requirements, mainly for automotive use. In any case of use of non-designated products, TI will not be responsible for any failure to meet ISO/TS16949.

Products

Audio	www.ti.com/audio
Amplifiers	amplifier.ti.com
Data Converters	dataconverter.ti.com
DLP® Products	www.dlp.com
DSP	dsp.ti.com
Clocks and Timers	www.ti.com/clocks
Interface	interface.ti.com
Logic	logic.ti.com
Power Mgmt	power.ti.com
Microcontrollers	microcontroller.ti.com
RFID	www.ti-rfid.com
OMAP Applications Processors	www.ti.com/omap
Wireless Connectivity	www.ti.com/wirelessconnectivity

Applications

Automotive and Transportation	www.ti.com/automotive
Communications and Telecom	www.ti.com/communications
Computers and Peripherals	www.ti.com/computers
Consumer Electronics	www.ti.com/consumer-apps
Energy and Lighting	www.ti.com/energy
Industrial	www.ti.com/industrial
Medical	www.ti.com/medical
Security	www.ti.com/security
Space, Avionics and Defense	www.ti.com/space-avionics-defense
Video and Imaging	www.ti.com/video

TI E2E Community

e2e.ti.com