

CURRENT-MODE PWM CONTROLLER

FEATURES

- Qualified for Automotive Applications
- Extended Temperature Performance of -40°C to 125°C
- Optimized for Off-Line and DC-to-DC Converters
- Low Start-Up Current ($<0.5\text{ mA}$)
- Trimmed Oscillator-Discharge Current
- Automatic Feed-Forward Compensation
- Pulse-by-Pulse Current Limiting
- Enhanced Load-Response Characteristics
- Under-Voltage Lockout With Hysteresis
- Double-Pulse Suppression
- High-Current Totem-Pole Output
- Internally Trimmed Bandgap Reference
- 500-kHz Operation
- Low R_o Error Amp

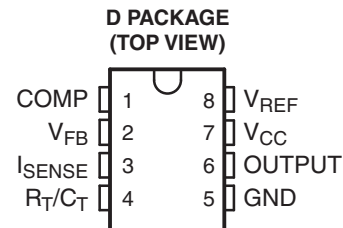

DESCRIPTION/ORDERING INFORMATION

The UC2843A control IC is a pin-for-pin compatible improved version of the UC2843. Providing the necessary features to control current mode switched mode power supplies, this device has the following improved features. Start up current is specified to be less than 0.5 mA. Oscillator discharge is trimmed to 8.3 mA. During undervoltage lockout, the output stage can sink at least 10 mA at less than 1.2 V for V_{CC} over 5 V.

PART NUMBER	UVLO ON	UVLO OFF	MAXIMUM DUTY CYCLE
UC2843A	8.5 V	7.9 V	<100%

ORDERING INFORMATION⁽¹⁾

T _A	PACKAGE ⁽²⁾		ORDERABLE PART NUMBER	TOP-SIDE MARKING
-40°C to 125°C	SOIC-8 – D8	Reel of 2500	UC2843AQD8RQ1	UC2843AQ

- (1) For the most current package and ordering information, see the Package Option Addendum at the end of this document, or see the TI web site at www.ti.com.
- (2) Package drawings, standard packing quantities, thermal data, symbolization, and PCB design guidelines are available at www.ti.com/sc/package.



Please be aware that an important notice concerning availability, standard warranty, and use in critical applications of Texas Instruments semiconductor products and disclaimers thereto appears at the end of this data sheet.

FUNCTIONAL BLOCK DIAGRAM

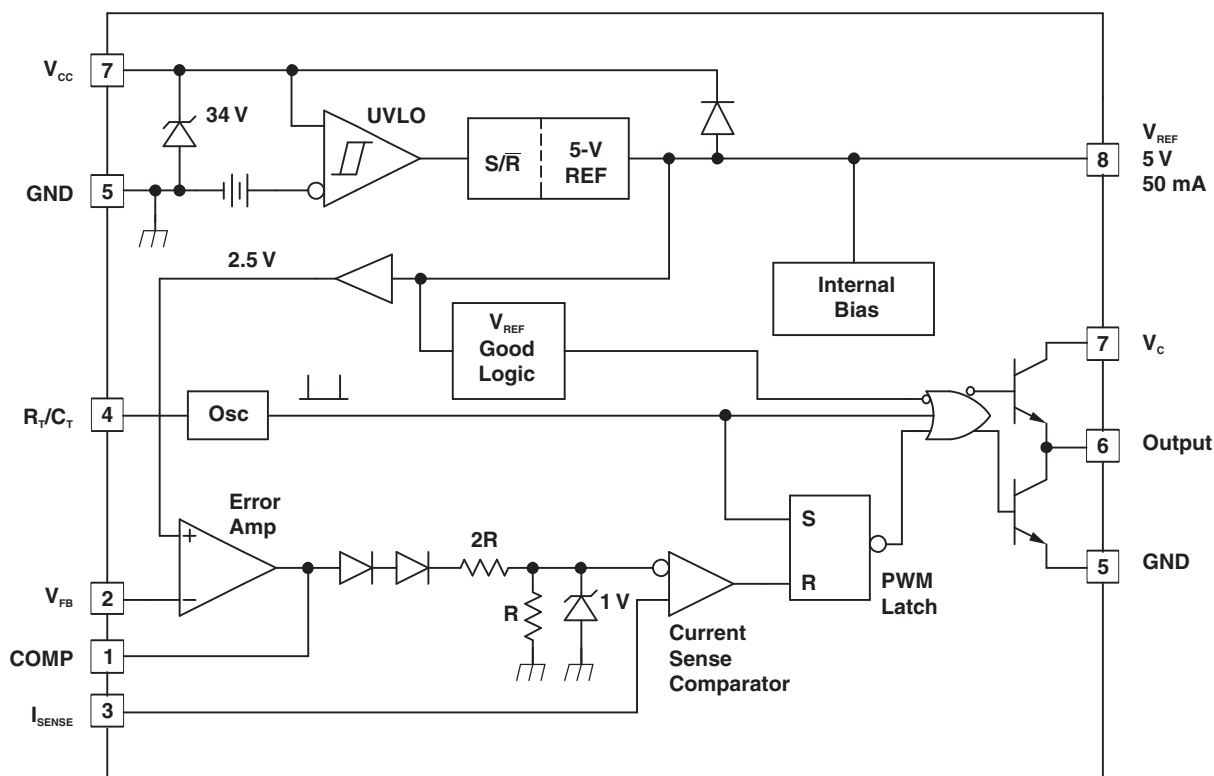
ABSOLUTE MAXIMUM RATINGS⁽¹⁾⁽²⁾

over operating free-air temperature range (unless otherwise noted)

	VALUE	UNIT
V_{CC} voltage (low impedance source)	30	V
V_{CC} voltage (I_{CC} mA)	Self limiting	
I_O Output current	± 1	A
Output energy (capacitive load)	5	μ J
Analog inputs (pins 3 and 5)	-0.3 to 6.3	V
Error amplifier output sink current	10	mA
Power dissipation at $T_A < 25^\circ\text{C}$ (14-pin D package)	1	W
θ_{JA} Package thermal impedance ⁽³⁾	97	$^\circ\text{C}/\text{W}$
T_{stg} Storage temperature range	-65 to 150	$^\circ\text{C}$
Lead temperature soldering 1,6 mm (1/16 inch) from case for 10 seconds	260	$^\circ\text{C}$

- (1) Stresses beyond those listed under *Absolute Maximum Ratings* may cause permanent damage to the device. These are stress ratings only, and functional operation of the device at these or any other conditions beyond those indicated under *Recommended Operating Conditions* is not implied. Exposure to absolute-maximum-rated conditions for extended periods may affect device reliability.
- (2) Unless otherwise indicated, voltages are reference to ground, and currents are positive into and negative out of the specified terminals.
- (3) Long-term high-temperature storage and/or extended use at maximum recommended operating conditions may result in a reduction of overall device life. See http://www.ti.com/ep_quality for additional information on enhanced plastic packaging.

ELECTRICAL CHARACTERISTICS

 $T_A = -40^{\circ}\text{C}$ to 125°C , $V_{CC} = 15\text{ V}^{(1)}$, $R_T = 10\text{ k}\Omega$, $C_T = 3.3\text{ nF}$, $T_A = T_J$ (unless otherwise stated)

PARAMETER	TEST CONDITIONS	MIN	TYP	MAX	UNIT	
Reference Section						
Output voltage	$T_J = 25^{\circ}\text{C}$, $I_O = 1\text{ mA}$	4.95	5.0	5.05	V	
Line regulation voltage	$V_{IN} = 12\text{ V}$ to 25 V		6	20	mV	
Load regulation voltage	$I_O = 1\text{ mA}$ to 20 mA		6	25	mV	
Temperature stability ⁽²⁾⁽³⁾			0.2	0.4	mV/ $^{\circ}\text{C}$	
Total output variation voltage	Line, load, temperature	4.9		5.1	V	
Output noise voltage	$f = 10\text{ Hz}$ to 10 kHz		50		μV	
Long term stability	1000 hours		5	25	mV	
Output short-circuit current		-30	-100	-180	mA	
Oscillator Section						
Initial accuracy ⁽⁴⁾	$T_J = 25^{\circ}\text{C}$	47	52	57	kHz	
Voltage stability	$V_{CC} = 12\text{ V}$ to 25 V		0.2	1	%	
Temperature stability	$T_A = \text{MIN}$ to MAX		5		%	
Amplitude peak-to-peak	V pin 7		1.7		V	
Discharge current ⁽⁵⁾	V pin 7 = 2 V	$T_J = 25^{\circ}\text{C}$	7.8	8.3	8.8	mA
		$T_J = \text{Full range}$	7.5		8.8	
Error Amplifier Section						
Input voltage	COMP = 2.5 V	2.45	2.5	2.55	V	
Input bias current			-0.3	-1	μA	
Open loop voltage gain (AVOL)	$V_O = 2\text{ V}$ to 4 V	65	90		dB	
Unity gain bandwidth ⁽³⁾	$T_J = 25^{\circ}\text{C}$	0.7	1		MHz	
PSRR	$V_{CC} = 12\text{ V}$ to 25 V	60	70		dB	
Output sink current	FB = 2.7 V , COMP = 1.1 V	2	6		mA	
Output source current	FB = 2.3 V , COMP = 5 V	-0.5	-0.8		mA	
VOUT high	FB = 2.3 V , $R_L = 15\text{ k}\Omega$ to GND	5	6		V	
VOUT low	FB = 2.7 V , $R_L = 15\text{ k}\Omega$ to V_{REF}		0.7	1.1	V	
Current Sense Section						
Gain ⁽⁶⁾⁽⁷⁾		2.85	3	3.15	V/V	
Maximum input signal ⁽⁶⁾	COMP = 5 V	0.9	1	1.1	V	
PSRR ⁽⁶⁾	$V_{CC} = 12\text{ V}$ to 25 V		70		dB	
Input bias current			-2	-10	μA	
Delay to output ⁽³⁾	$I_{SENSE} = 0\text{ V}$ to 2 V		150	300	ns	

(1) Adjust V_{CC} above the start threshold before setting at 15 V .

(2) Temperature stability, sometimes referred to as average temperature coefficient, is described by the equation:

Temperature Stability = $(V_{REF}(\text{max}) - V_{REF}(\text{min})) / (T_J(\text{max}) - T_J(\text{min}))$. $V_{REF}(\text{max})$ and $V_{REF}(\text{min})$ are the maximum and minimum reference voltage measured over the appropriate temperature range. Note that the extremes in voltage do not necessarily occur at the extremes in temperature.

(3) Specified by design.

(4) Output frequency equals oscillator frequency for the UC2843A.

(5) This parameter is measured with $R_T = 10\text{ k}\Omega$ to V_{REF} . This contributes approximately $300\text{ }\mu\text{A}$ of current to the measurement. The total current flowing into the R_T/R_C pin is approximately $300\text{ }\mu\text{A}$ higher than the measured value.

(6) Parameter measured at trip point of latch with V_{FB} at 0 V .

(7) Gain is defined by: $A = \Delta V_{COMP} / \Delta V_{SENSE}$; $0 \leq V_{SENSE} \leq 0.8\text{ V}$.

ELECTRICAL CHARACTERISTICS (continued)
 $T_A = -40^{\circ}\text{C}$ to 125°C , $V_{CC} = 15\text{ V}$, $R_T = 10\text{ k}\Omega$, $C_T = 3.3\text{ nF}$, $T_A = T_J$ (unless otherwise stated)

PARAMETER	TEST CONDITIONS		MIN	TYP	MAX	UNIT
Output Section (OUT)						
Low level output voltage	$I_{OUT} = 20\text{ mA}$			0.1	0.4	V
	$I_{OUT} = 200\text{ mA}$			15	2.2	
High level output voltage	$I_{OUT} = -20\text{ mA}$		13	13.5		V
	$I_{OUT} = -200\text{ mA}$		12	13.5		
Rise time ⁽⁸⁾	$C_L = 1\text{ nF}$	$T_J = 25^{\circ}\text{C}$		50	150	ns
Fall time ⁽⁸⁾	$C_L = 1\text{ nF}$	$T_J = 25^{\circ}\text{C}$		50	150	ns
UVLO saturation	$V_{CC} = 5\text{ V}$, $I_{OUT} = 10\text{ mA}$			0.7	1.2	V
Undervoltage Lockout Section (UVLO)						
Start threshold			7.8	8.4	9	V
Minimum operation voltage after turn on			7	7.6	8.2	V
PWM Section						
Maximum duty cycle			94	96	100	%
Minimum duty cycle					0	%
Total Standby Current						
Start-up current				0.3	0.5	mA
Operating supply current	$FB = 0\text{ V}$, $SENSE = 0\text{ V}$			11	17	mA
V_{CC} internal zener voltage	$I_{CC} = 25\text{ mA}$		30	34		V

(8) Specified by design.

PARAMETER MEASUREMENT INFORMATION

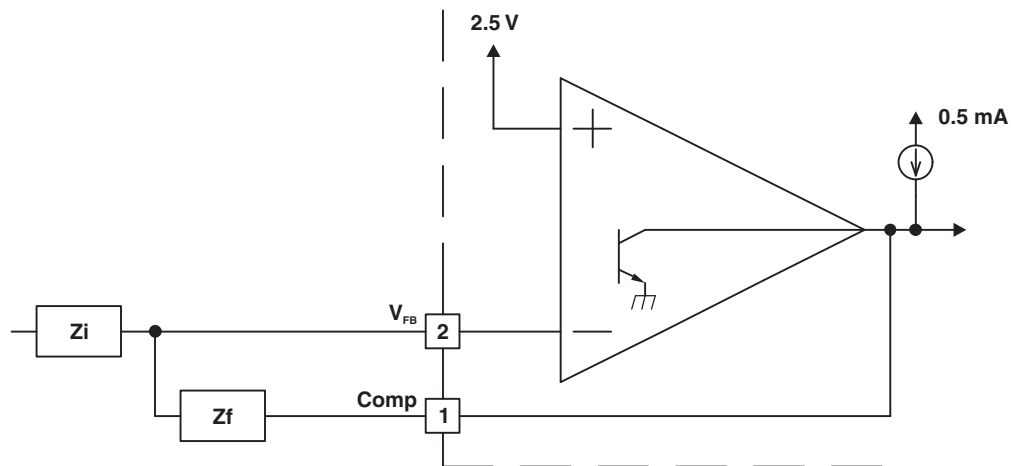

A. The error amplifier can source up to 0.5 mA and sink up to 2 mA.

Figure 1. Error Amp Configuration

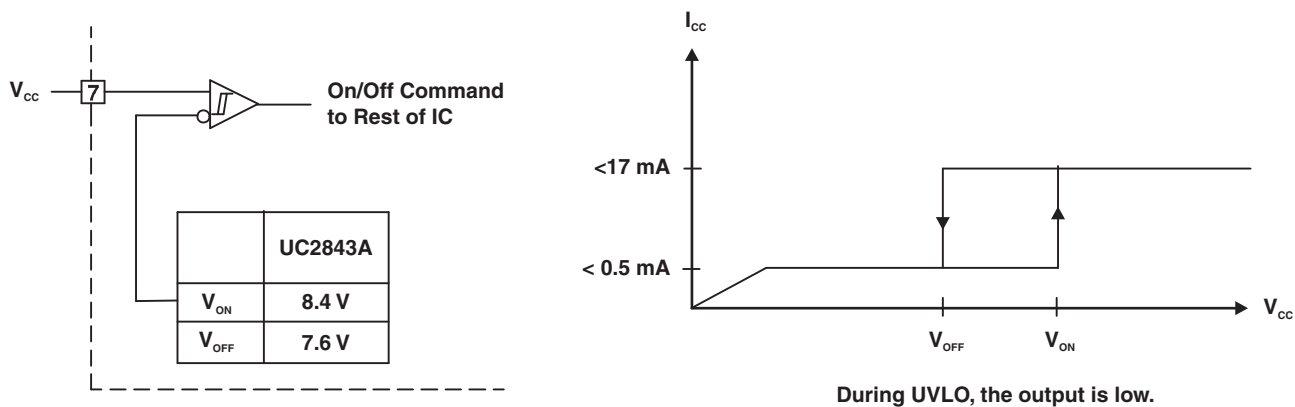
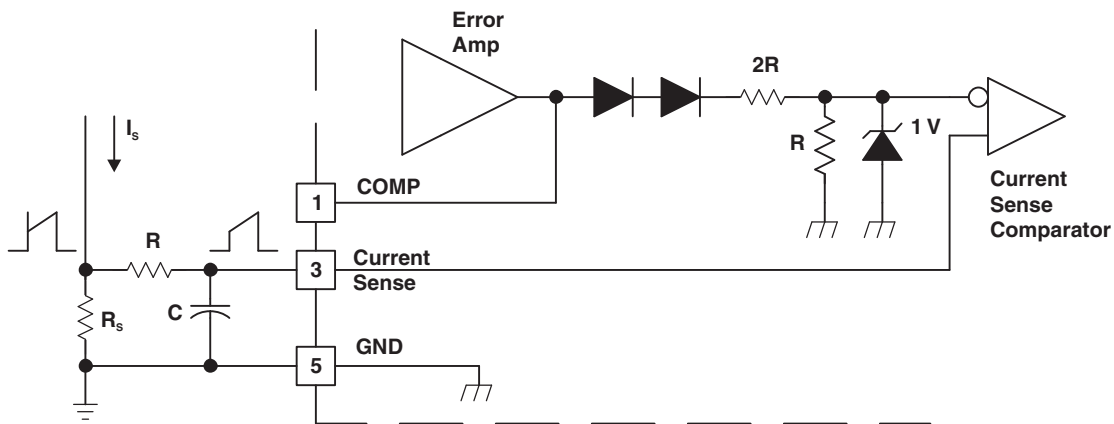

Figure 2. Undervoltage Lockout



A. Peak current (I_s) is determined by the formula: $I_{smax} = 1.0 V/R_s$
 A small RC filter may be required to suppress switch transients.

Figure 3. Current Sense Circuit

PARAMETER MEASUREMENT INFORMATION (continued)

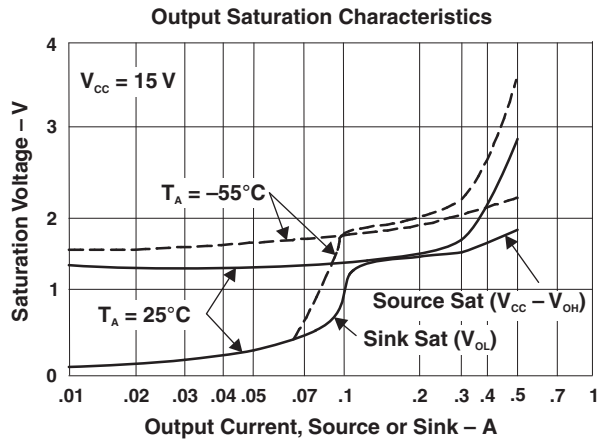

Figure 4.

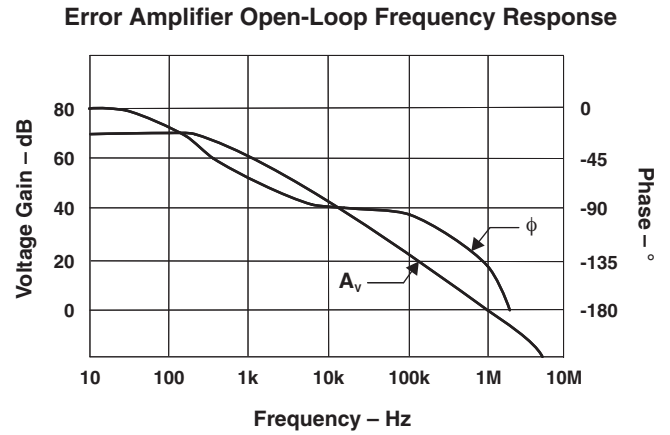

Figure 5.

APPLICATION INFORMATION

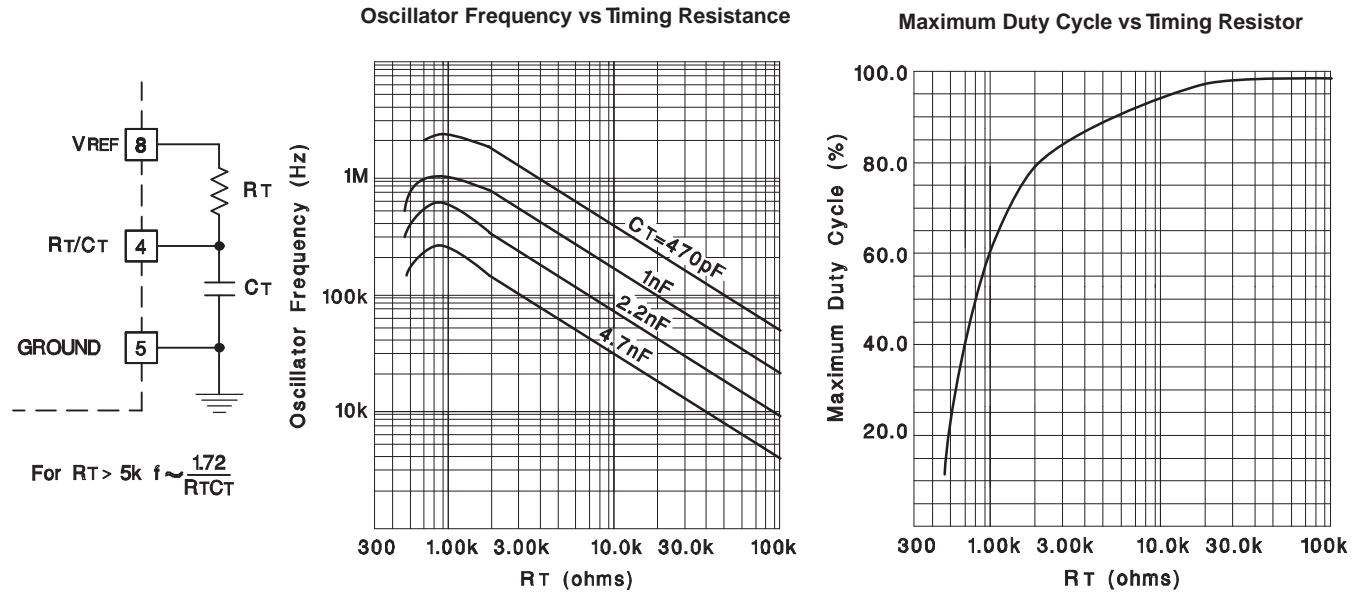
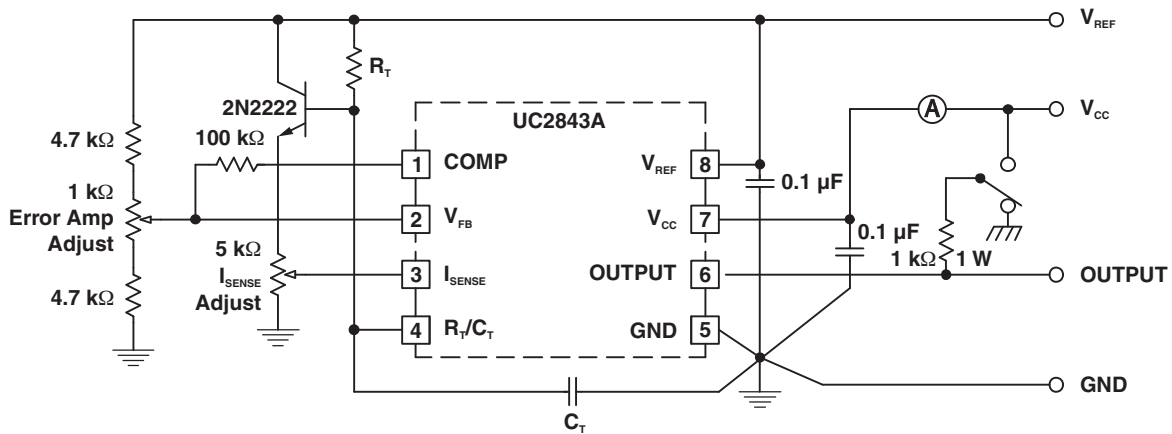
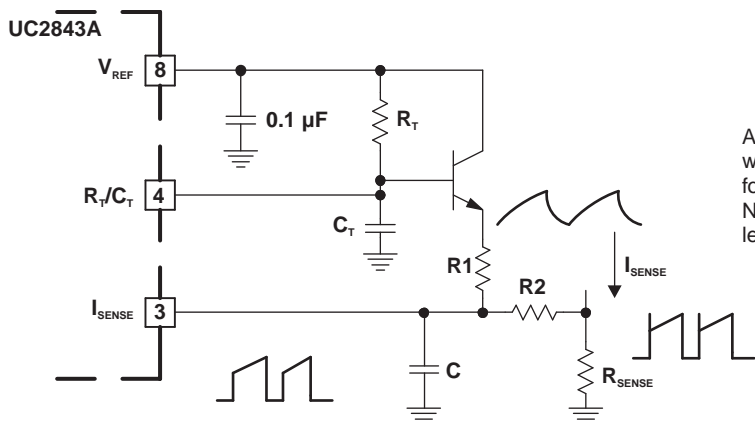

Figure 6. Oscillator



- A. High peak currents associated with capacitive loads necessitate careful grounding techniques. Timing and bypass capacitors should be connected close to pin 5 in a single point ground. The transistor and 5k potentiometer are used to sample the oscillator waveform and apply an adjustable ramp to pin 3.

Figure 7. Open-Loop Laboratory Text Fixture



A fraction of the oscillator ramp can be resistively summed with the current sense signal to provide slope compensation for converters requiring duty cycles over 50%. Note that capacitor C forms a filter with R2 to suppress the leading-edge switch spikes.

Figure 8. Slope Compression

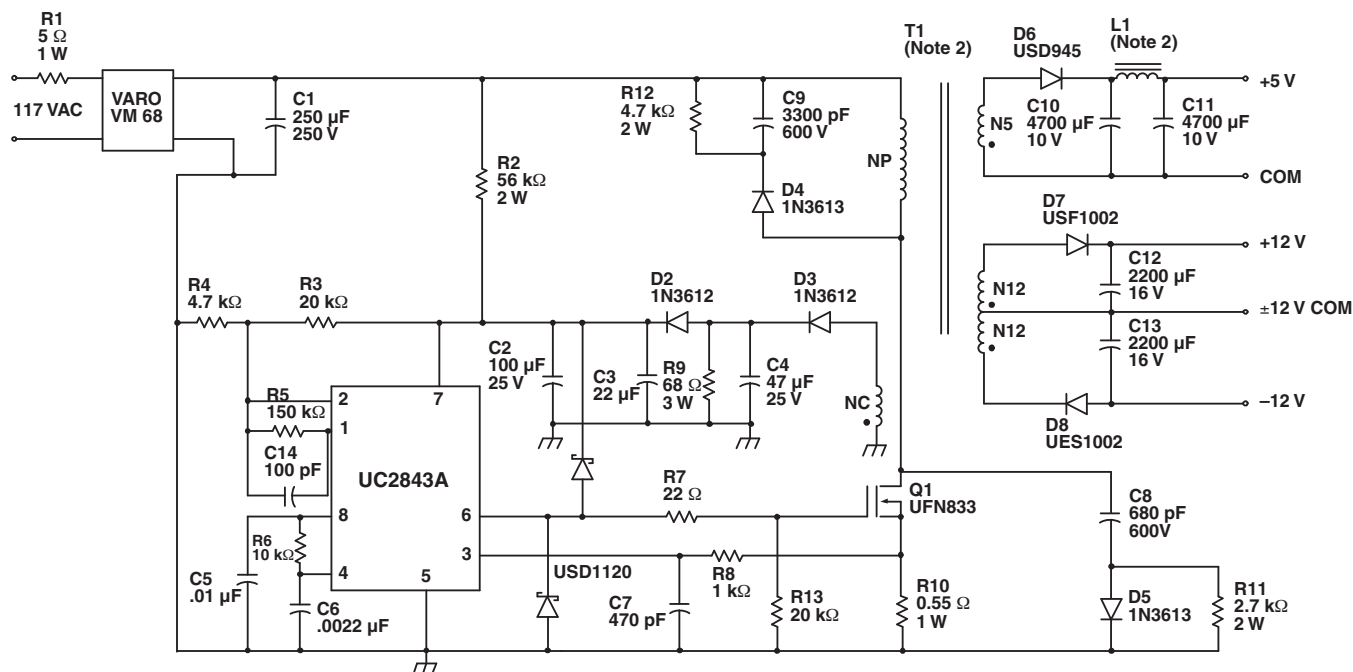

Power Supply Specifications

1. Input Voltage 95 VAC to 130 VAC (50 Hz/60 Hz)
2. Line Isolation 3750 V
3. Switching Frequency 40 kHz
4. Efficiency, Full Load 70%
5. Output Voltage:
 - A. 5 V \pm 5%; 1-A to 4-A Load
 - B. 12 V \pm 3%; 0.1-A to 0.3-A Load; Ripple voltage: 100 mV P-P Max
 - C. -12 V \pm 3%; 0.1-A to 0.3-A Load; Ripple voltage: 100 mV P-P Max

Figure 9. Off-Line Flyback Regulator

PACKAGING INFORMATION

Orderable Device	Status (1)	Package Type	Package Drawing	Pins	Package Qty	Eco Plan (2)	Lead/Ball Finish (6)	MSL Peak Temp (3)	Op Temp (°C)	Device Marking (4/5)	Samples
UC2843AQD8RG4Q1	ACTIVE	SOIC	D	8	2500	Green (RoHS & no Sb/Br)	CU NIPDAU	Level-1-260C-UNLIM	-40 to 125	(2843AQ ~ UC2843AQ)	Samples
UC2843AQD8RQ1	ACTIVE	SOIC	D	8	2500	Green (RoHS & no Sb/Br)	CU NIPDAU	Level-1-260C-UNLIM	-40 to 125	(2843AQ ~ UC2843AQ)	Samples

(1) The marketing status values are defined as follows:

ACTIVE: Product device recommended for new designs.

LIFEBUY: TI has announced that the device will be discontinued, and a lifetime-buy period is in effect.

NRND: Not recommended for new designs. Device is in production to support existing customers, but TI does not recommend using this part in a new design.

PREVIEW: Device has been announced but is not in production. Samples may or may not be available.

OBSELETE: TI has discontinued the production of the device.

(2) Eco Plan - The planned eco-friendly classification: Pb-Free (RoHS), Pb-Free (RoHS Exempt), or Green (RoHS & no Sb/Br) - please check <http://www.ti.com/productcontent> for the latest availability information and additional product content details.

TBD: The Pb-Free/Green conversion plan has not been defined.

Pb-Free (RoHS): TI's terms "Lead-Free" or "Pb-Free" mean semiconductor products that are compatible with the current RoHS requirements for all 6 substances, including the requirement that lead not exceed 0.1% by weight in homogeneous materials. Where designed to be soldered at high temperatures, TI Pb-Free products are suitable for use in specified lead-free processes.

Pb-Free (RoHS Exempt): This component has a RoHS exemption for either 1) lead-based flip-chip solder bumps used between the die and package, or 2) lead-based die adhesive used between the die and leadframe. The component is otherwise considered Pb-Free (RoHS compatible) as defined above.

Green (RoHS & no Sb/Br): TI defines "Green" to mean Pb-Free (RoHS compatible), and free of Bromine (Br) and Antimony (Sb) based flame retardants (Br or Sb do not exceed 0.1% by weight in homogeneous material)

(3) MSL, Peak Temp. - The Moisture Sensitivity Level rating according to the JEDEC industry standard classifications, and peak solder temperature.

(4) There may be additional marking, which relates to the logo, the lot trace code information, or the environmental category on the device.

(5) Multiple Device Markings will be inside parentheses. Only one Device Marking contained in parentheses and separated by a "~" will appear on a device. If a line is indented then it is a continuation of the previous line and the two combined represent the entire Device Marking for that device.

(6) Lead/Ball Finish - Orderable Devices may have multiple material finish options. Finish options are separated by a vertical ruled line. Lead/Ball Finish values may wrap to two lines if the finish value exceeds the maximum column width.

Important Information and Disclaimer: The information provided on this page represents TI's knowledge and belief as of the date that it is provided. TI bases its knowledge and belief on information provided by third parties, and makes no representation or warranty as to the accuracy of such information. Efforts are underway to better integrate information from third parties. TI has taken and continues to take reasonable steps to provide representative and accurate information but may not have conducted destructive testing or chemical analysis on incoming materials and chemicals. TI and TI suppliers consider certain information to be proprietary, and thus CAS numbers and other limited information may not be available for release.

In no event shall TI's liability arising out of such information exceed the total purchase price of the TI part(s) at issue in this document sold by TI to Customer on an annual basis.

OTHER QUALIFIED VERSIONS OF UC2843A-Q1 :

- Catalog: [UC2843A](#)

NOTE: Qualified Version Definitions:

- Catalog - TI's standard catalog product

D (R-PDSO-G8)

PLASTIC SMALL OUTLINE

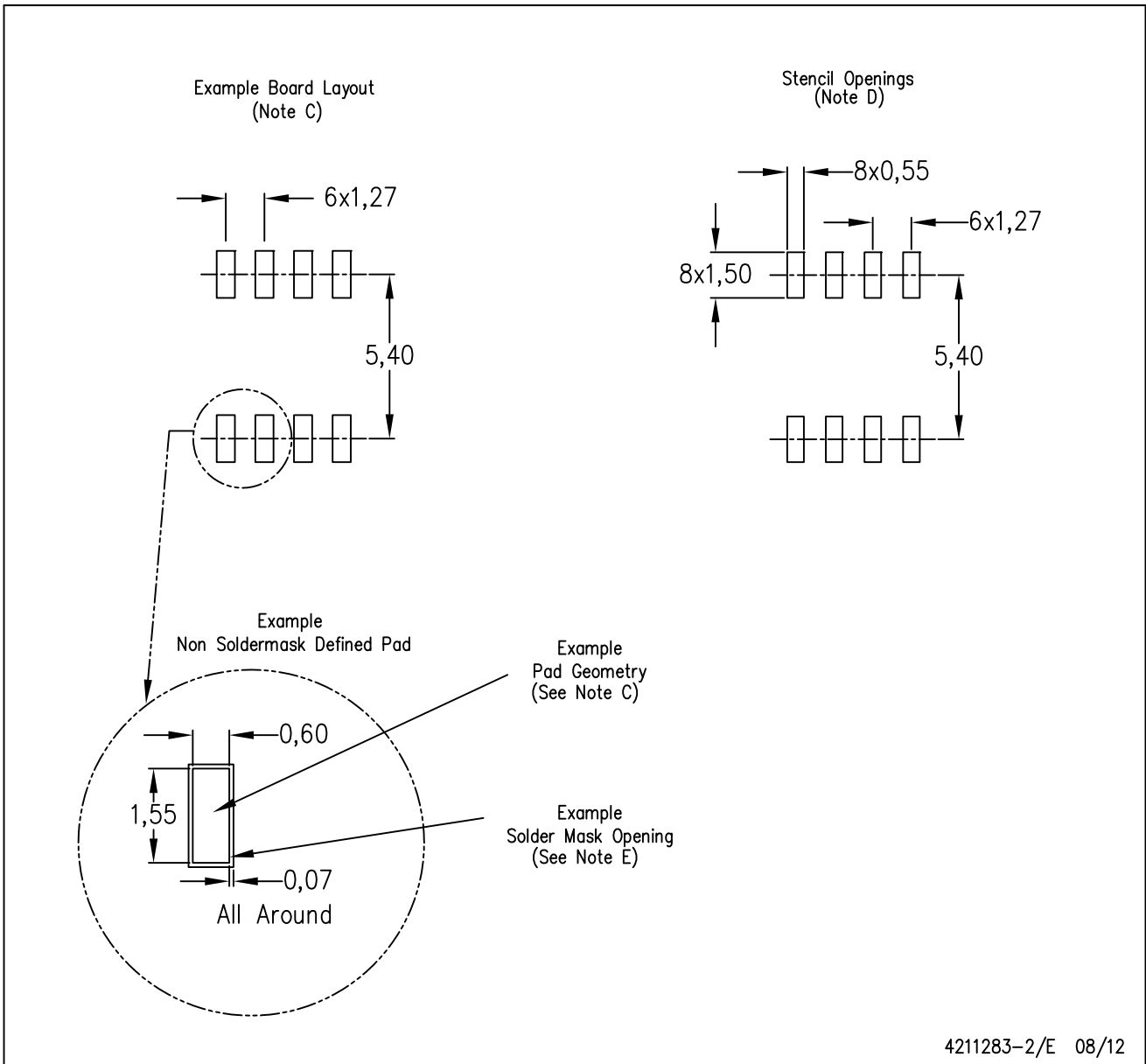

- NOTES:
- A. All linear dimensions are in millimeters.
 - B. This drawing is subject to change without notice.
 - C. Publication IPC-7351 is recommended for alternate designs.
 - D. Laser cutting apertures with trapezoidal walls and also rounding corners will offer better paste release. Customers should contact their board assembly site for stencil design recommendations. Refer to IPC-7525 for other stencil recommendations.
 - E. Customers should contact their board fabrication site for solder mask tolerances between and around signal pads.

IMPORTANT NOTICE

Texas Instruments Incorporated and its subsidiaries (TI) reserve the right to make corrections, enhancements, improvements and other changes to its semiconductor products and services per JESD46, latest issue, and to discontinue any product or service per JESD48, latest issue. Buyers should obtain the latest relevant information before placing orders and should verify that such information is current and complete. All semiconductor products (also referred to herein as "components") are sold subject to TI's terms and conditions of sale supplied at the time of order acknowledgment.

TI warrants performance of its components to the specifications applicable at the time of sale, in accordance with the warranty in TI's terms and conditions of sale of semiconductor products. Testing and other quality control techniques are used to the extent TI deems necessary to support this warranty. Except where mandated by applicable law, testing of all parameters of each component is not necessarily performed.

TI assumes no liability for applications assistance or the design of Buyers' products. Buyers are responsible for their products and applications using TI components. To minimize the risks associated with Buyers' products and applications, Buyers should provide adequate design and operating safeguards.

TI does not warrant or represent that any license, either express or implied, is granted under any patent right, copyright, mask work right, or other intellectual property right relating to any combination, machine, or process in which TI components or services are used. Information published by TI regarding third-party products or services does not constitute a license to use such products or services or a warranty or endorsement thereof. Use of such information may require a license from a third party under the patents or other intellectual property of the third party, or a license from TI under the patents or other intellectual property of TI.

Reproduction of significant portions of TI information in TI data books or data sheets is permissible only if reproduction is without alteration and is accompanied by all associated warranties, conditions, limitations, and notices. TI is not responsible or liable for such altered documentation. Information of third parties may be subject to additional restrictions.

Resale of TI components or services with statements different from or beyond the parameters stated by TI for that component or service voids all express and any implied warranties for the associated TI component or service and is an unfair and deceptive business practice. TI is not responsible or liable for any such statements.

Buyer acknowledges and agrees that it is solely responsible for compliance with all legal, regulatory and safety-related requirements concerning its products, and any use of TI components in its applications, notwithstanding any applications-related information or support that may be provided by TI. Buyer represents and agrees that it has all the necessary expertise to create and implement safeguards which anticipate dangerous consequences of failures, monitor failures and their consequences, lessen the likelihood of failures that might cause harm and take appropriate remedial actions. Buyer will fully indemnify TI and its representatives against any damages arising out of the use of any TI components in safety-critical applications.

In some cases, TI components may be promoted specifically to facilitate safety-related applications. With such components, TI's goal is to help enable customers to design and create their own end-product solutions that meet applicable functional safety standards and requirements. Nonetheless, such components are subject to these terms.

No TI components are authorized for use in FDA Class III (or similar life-critical medical equipment) unless authorized officers of the parties have executed a special agreement specifically governing such use.

Only those TI components which TI has specifically designated as military grade or "enhanced plastic" are designed and intended for use in military/aerospace applications or environments. Buyer acknowledges and agrees that any military or aerospace use of TI components which have **not** been so designated is solely at the Buyer's risk, and that Buyer is solely responsible for compliance with all legal and regulatory requirements in connection with such use.

TI has specifically designated certain components as meeting ISO/TS16949 requirements, mainly for automotive use. In any case of use of non-designated products, TI will not be responsible for any failure to meet ISO/TS16949.

Products

Audio	www.ti.com/audio
Amplifiers	amplifier.ti.com
Data Converters	dataconverter.ti.com
DLP® Products	www.dlp.com
DSP	dsp.ti.com
Clocks and Timers	www.ti.com/clocks
Interface	interface.ti.com
Logic	logic.ti.com
Power Mgmt	power.ti.com
Microcontrollers	microcontroller.ti.com
RFID	www.ti-rfid.com
OMAP Applications Processors	www.ti.com/omap
Wireless Connectivity	www.ti.com/wirelessconnectivity

Applications

Automotive and Transportation	www.ti.com/automotive
Communications and Telecom	www.ti.com/communications
Computers and Peripherals	www.ti.com/computers
Consumer Electronics	www.ti.com/consumer-apps
Energy and Lighting	www.ti.com/energy
Industrial	www.ti.com/industrial
Medical	www.ti.com/medical
Security	www.ti.com/security
Space, Avionics and Defense	www.ti.com/space-avionics-defense
Video and Imaging	www.ti.com/video

TI E2E Community

e2e.ti.com