

SDIO PORT EXPANDER WITH VOLTAGE-LEVEL TRANSLATION

FEATURES

- 6-to-12 Demultiplexer/Multiplexer Allows SDIO Port Expansion
- Built-in Level Translator Eliminates Voltage Mismatch Between Baseband and SD Card or SDIO Peripheral
- V_{CCA} , V_{CCB0} , and V_{CCB1} Each Operate Over Full 1.1-V to 3.6-V Range
- Latch-Up Performance Exceeds 100 mA Per JESD 78, Class II
- ESD Performance A Port
 - 2000-V Human-Body Model (A114-B)
 - 100-V Machine Model (A115-A)
 - 1500-V Charged-Device Model (C101)
- ± 8 -kV Contact Discharge IEC 61000-4-2 ESD Performance (B Port)

DESCRIPTION/ORDERING INFORMATION

The TXS02612 is designed to interface the cell phone baseband with external SDIO peripherals. The device includes a 6-channel SPDT switch with voltage-level translation capability. This allows a single SDIO port to be interfaced with two SDIO peripherals. The TXS02612 has three separate supply rails that operate over the full range of 1.1 V to 3.6 V. This allows the baseband and SDIO peripherals to operate at different supply voltages if required.

The select (SEL) input is used to choose between the B0 port and B1 port. When SEL = Low, B0 port is selected; when SEL = High, B1 port is selected. SEL is referenced to V_{CCA} . For the unselected B port, the clock output is held low, whereas the data and command I/Os are pulled high to their respective V_{CCB} through a 70-k Ω resistor ($\pm 30\%$ tolerance).

ORDERING INFORMATION⁽¹⁾

T_A	PACKAGE ⁽²⁾		ORDERABLE PART NUMBER	TOP-SIDE MARKING
–40°C to 85°C	MicroStar Junior™ BGA (VFBGA) – ZQS	Reel of 3000	TXS02612ZQSR	YJ612
	QFN – RTW	Reel of 3000	TXS02612RTWR	YJ612

(1) For the most current package and ordering information, see the Package Option Addendum at the end of this document, or see the TI web site at www.ti.com.

(2) Package drawings, thermal data, and symbolization are available at www.ti.com/packaging.

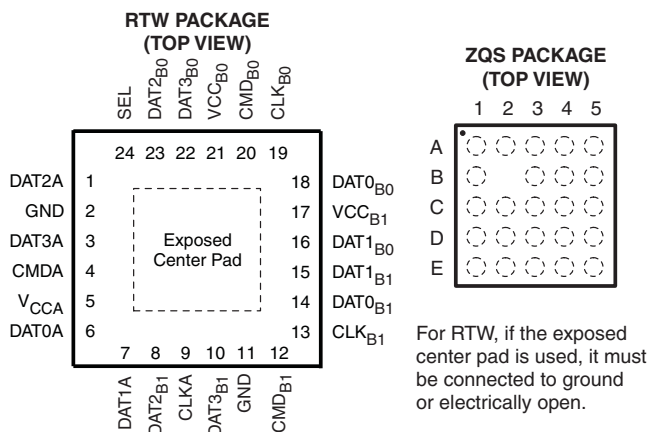

Table 1. ZQS PACKAGE TERMINAL ASSIGNMENTS

	1	2	3	4	5
A	DAT2A	SEL	DAT3 _{B0}	CMD _{B0}	CLK _{B0}
B	DAT3A		DAT2 _{B0}	V_{CCB0}	DAT0 _{B0}
C	CMDA	V_{CCA}	GND	V_{CCB1}	DAT1 _{B0}
D	DAT0A	CLKA	GND	DAT1 _{B1}	DAT0 _{B1}
E	DAT1A	DAT2 _{B1}	DAT3 _{B1}	CMD _{B1}	CLK _{B1}



Please be aware that an important notice concerning availability, standard warranty, and use in critical applications of Texas Instruments semiconductor products and disclaimers thereto appears at the end of this data sheet.

APPLICATION BLOCK DIAGRAM

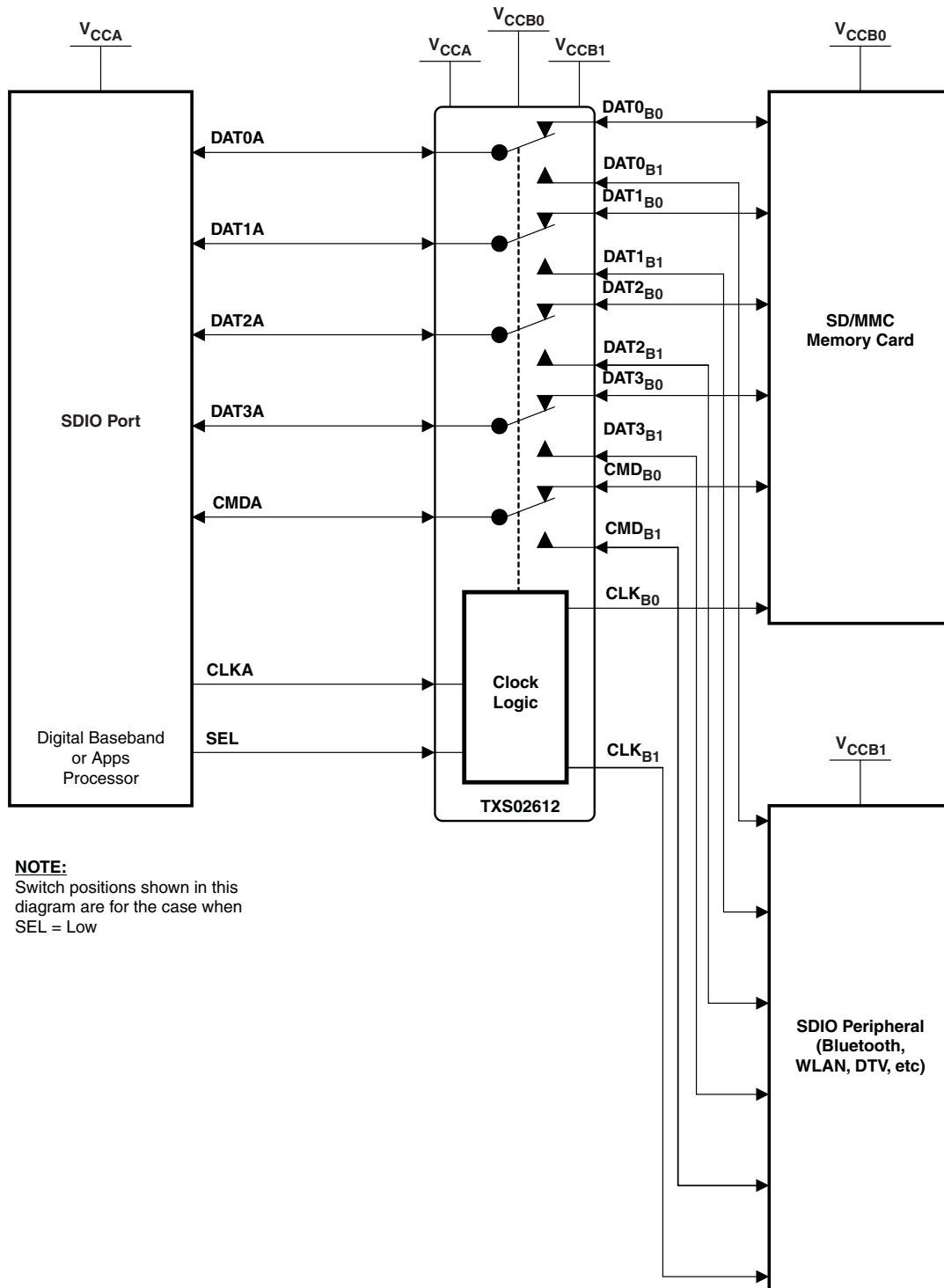

NOTE:
Switch positions shown in this diagram are for the case when $SEL = Low$

PIN ASSIGNMENTS

RTW PACKAGE PIN NO.	ZQS PACKAGE BALL NO.	NAME	FUNCTION	TYPE
1	A1	DAT2A	Data bit 2. Referenced to V_{CCA} .	I/O
3	B1	DAT3A	Data bit 3. Referenced to V_{CCA} .	I/O
4	C1	CMDA	Command bit. Referenced to V_{CCA} .	I/O
6	D1	DAT0A	Data bit 0. Referenced to V_{CCA} .	I/O
7	E1	DAT1A	Data bit 1. Referenced to V_{CCA} .	I/O
24	A2	SEL	Select pin to choose between B0 and B1. Referenced to V_{CCA} .	Input
	B2		Depopulated	
5	C2	V_{CCA}	A-port supply voltage. $1.1\text{ V} \leq V_{CCA} \leq 3.6\text{ V}$.	Power
9	D2	CLKA	Clock input A. Referenced to V_{CCA} .	Input
8	E2	DAT2 _{B1}	Data bit 2. Referenced to V_{CCB1} .	I/O
22	A3	DAT3 _{B0}	Data bit 3. Referenced to V_{CCB0} .	I/O
23	B3	DAT2 _{B0}	Data bit 2. Referenced to V_{CCB0} .	I/O
2	C3	GND	Ground	
11	D3	GND	Ground	
10	E3	DAT3 _{B1}	Data bit 3. Referenced to V_{CCB1} .	I/O
20	A4	CMD _{B0}	Command bit. Referenced to V_{CCB0} .	I/O
21	B4	V_{CCB0}	B0-port supply voltage. $1.1\text{ V} \leq V_{CCB0} \leq 3.6\text{ V}$.	Power
17	C4	V_{CCB1}	B1-port supply voltage. $1.1\text{ V} \leq V_{CCB1} \leq 3.6\text{ V}$.	Power
15	D4	DAT1 _{B1}	Data bit 1. Referenced to V_{CCB1} .	I/O
12	E4	CMD _{B1}	Command bit. Referenced to V_{CCB1} .	I/O
19	A5	CLK _{B0}	Clock output. Referenced to V_{CCB0} .	Output
18	B5	DAT0 _{B0}	Data bit 0. Referenced to V_{CCB0} .	I/O
16	C5	DAT1 _{B0}	Data bit 1. Referenced to V_{CCB0} .	I/O
14	D5	DAT0 _{B1}	Data bit 0. Referenced to V_{CCB1} .	I/O
13	E5	CLK _{B1}	Clock output. Referenced to V_{CCB1} .	Output

SIMPLIFIED INTERNAL STRUCTURE

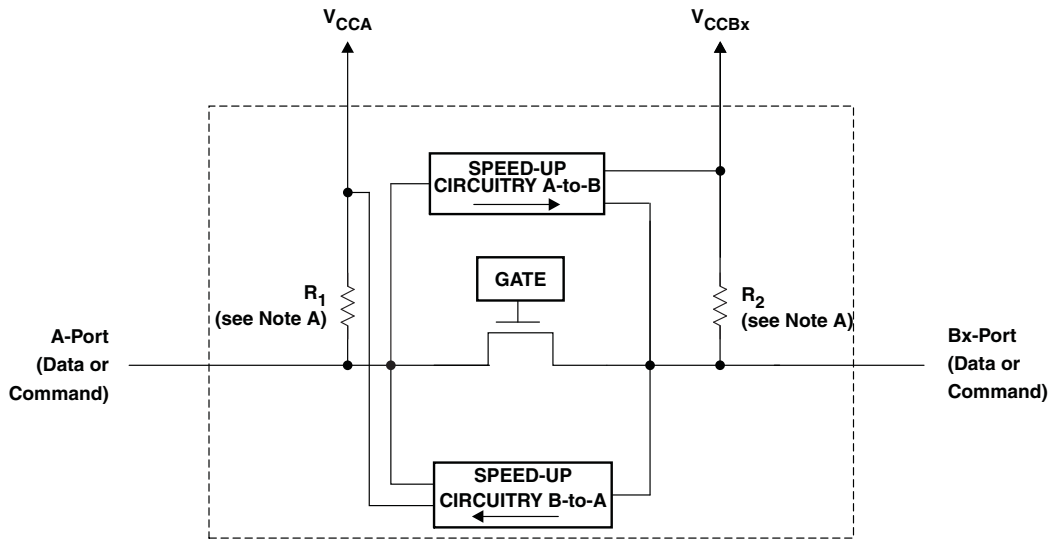

Simplified Architecture of Command and Each Data Path

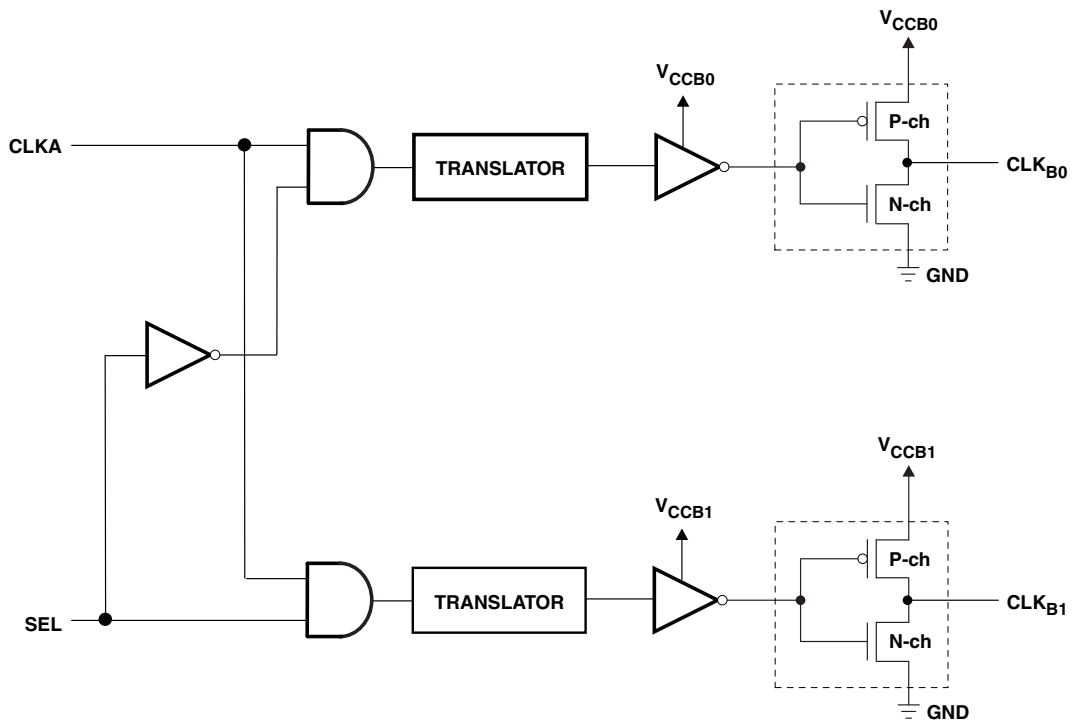

Simplified Architecture of the Clock Path

- A. R_1 and R_2 resistor values are determined based upon the logic level applied to the A port or B port, as follows:
 R_1 and $R_2 = 40\text{ k}\Omega$ when a logic level low is applied to the A port or B port.
 R_1 and $R_2 = 4\text{ k}\Omega$ when a logic level high is applied to the A port or B port.
 R_1 and $R_2 = 70\text{ k}\Omega$ when the port is deselected.

FUNCTION TABLE

Clock Channel			
SEL	CLKB0	CLKB1	OPERATION
L	Active	Low	CLKA to CLKB0
H	Low	Active	CLKA to CLKB1
Data and Command Channel			
SEL	DATxB0 or CMDxB0	DATxB1 or CMDxB1	OPERATION
L	Active	Disabled, pulled to V_{CCB1} through 70 k Ω	DATxA to DATxB0, CMDA to CMDB0
H	Disabled, pulled to V_{CCB0} through 70 k Ω	Active	DATxA to DATxB1, CMDA to CMDB1

ABSOLUTE MAXIMUM RATINGS^{(1) (2)}

over operating free-air temperature range (unless otherwise noted)

		MIN	MAX	UNIT
V_{CCA} V_{CCB0} V_{CCB1}	Supply voltage range ⁽²⁾	-0.5	4.6	V
V_I	Input voltage range	-0.5	$V_{CCx} + 0.5$	V
V_O	Voltage range applied to any output in the high-impedance or power-off state	-0.5	$V_{CCx} + 0.5$	V
I_{IK}	Input clamp current	$V_I < 0$	-50	mA
I_{OK}	Output clamp current	$V_O < 0$	-50	mA
$I_{CC}/$ I_{GND}	Continuous current through V_{CCA} , V_{CCB0} , V_{CCB1} , or GND		± 100	mA
T_{stg}	Storage temperature range	-65	150	$^{\circ}\text{C}$

- (1) Stresses beyond those listed under "absolute maximum ratings" may cause permanent damage to the device. These are stress ratings only, and functional operation of the device at these or any other conditions beyond those indicated under "recommended operating conditions" is not implied. Exposure to absolute-maximum-rated conditions for extended periods may affect device reliability.
- (2) The input and output voltage ratings may be exceeded if the input and output clamp-current ratings are observed.

PACKAGE THERMAL IMPEDANCE

PARAMETER			UNIT
θ_{JA}	Package thermal impedance	RTW package	66
		ZQS package	171.6

RECOMMENDED OPERATING CONDITIONS

		V_{CCA}	$V_{CCBx}^{(1)}$	MIN	MAX	UNIT	
V_{CCA} V_{CCB0} V_{CCB1}	Supply voltage			1.1	3.6	V	
V_{IH}	High-level input voltage	A-port I/Os	1.1 V to 3.6 V	1.1 V to 3.6 V	$V_{CCI} - 0.2$	V_{CCI}	V
		B-port I/Os			$V_{CCI} - 0.2$	V_{CCI}	
		SEL, CLKA			$V_{CCA} \times 0.65$ V	3.6	
V_{IL}	Low-level input voltage	A-port I/Os	1.1 V to 3.6 V	1.1 V to 3.6 V	0	0.15	V
		B-port I/Os			0	0.15	
		SEL, CLKA			0	$V_{CCA} \times 0.35$	
$\Delta t/\Delta v$	Input transition rise or fall rate	CLK, SEL			10	ns/V	
T_A	Operating free-air temperature			-40	85	°C	

(1) V_{CCBx} refers to V_{CCB0} and V_{CCB1} .

ELECTRICAL CHARACTERISTICS

over recommended operating free-air temperature range (unless otherwise noted)

PARAMETER	TEST CONDITIONS	V_{CCA}	V_{CCBx}	$T_A = 25^\circ\text{C}$	$T_A = -40^\circ\text{C to } 85^\circ\text{C}$		UNIT
				TYP	MIN	MAX	
V_{OHA} (DATA & CMD)	$I_{OH} = -20 \mu\text{A}$, $V_{IBx} \geq V_{CCBx} - 0.2$ V	1.1 V	1.1 V		0.74		V
		1.4 V	1.4 V		$V_{CCA} \times 0.67$		
		1.65 V	1.65 V		$V_{CCA} \times 0.67$		
		2.3 V	2.3 V		$V_{CCA} \times 0.67$		
		3 V	3 V		$V_{CCA} \times 0.67$		
V_{OLA} (DATA & CMD)	$I_{OL} = 135 \mu\text{A}$, $V_{IBx} \leq 0.15$ V	1.1 V	1.1 V		0.35		V
		1.4 V	1.4 V		0.35		
		1.65 V	1.65 V		0.45		
		2.3 V	2.3 V		0.55		
		3 V	3 V		0.70		
V_{OHB} (DATA & CMD)	$I_{OH} = -20 \mu\text{A}$, $V_{IAX} \geq V_{CCA} - 0.2$ V	1.1 V	1.1 V		0.74		V
		1.4 V	1.4 V		$V_{CCBx} \times 0.67$		
		1.65 V	1.65 V		$V_{CCBx} \times 0.67$		
		2.3 V	2.3 V		$V_{CCBx} \times 0.67$		
		3 V	3 V		$V_{CCBx} \times 0.67$		
V_{OHCLKB}	$I_{OH} = -0.5$ mA	1.1 V	1.1 V		0.74		V
		1.4 V	1.4 V		1.05		
		1.65 V	1.65 V		1.2		
		2.3 V	2.3 V		1.75		
		3 V	3 V		2.3		
V_{OLB} (DATA & CMD)	$I_{OL} = 135 \mu\text{A}$, $V_{IAX} \leq 0.15$ V	1.1 V	1.1 V		0.35		V
		1.4 V	1.4 V		0.35		
		1.65 V	1.65 V		0.45		
		2.3 V	2.3 V		0.55		
		3 V	3 V		0.70		
V_{OLCLKB}	$I_{OL} = 0.5$ mA	1.1 V	1.1 V		0.35		V
		1.4 V	1.4 V		0.35		
		1.65 V	1.65 V		0.45		
		2.3 V	2.3 V		0.55		
		3 V	3 V		0.7		

ELECTRICAL CHARACTERISTICS (continued)

over recommended operating free-air temperature range (unless otherwise noted)

PARAMETER	TEST CONDITIONS	V _{CCA}	V _{CCBx}	T _A = 25°C		T _A = -40°C to 85°C		UNIT
				TYP	MIN	MAX		
I _I	SEL, CLKA	1.1 V to 3.6 V	1.1 V to 3.6 V	±1	±2		μA	
	DAT, CMD			±1	±2			
I _{CCA}	V _I = V _O = Open, I _O = 0, SEL, CLK = High or Low	1.1 V to 3.6 V	1.1 V to 3.6 V		12		μA	
		3.6 V	0 V		12			
		0 V	3.6 V		-1			
I _{CCB0} or I _{CCB1}	V _I = V _O = Open, I _O = 0, SEL, CLK = High or Low	1.1 V to 3.6 V	1.1 V to 3.6 V		24		μA	
		3.6 V	0 V		-12			
		0 V	3.6 V		24			
C _i	SEL, CLKA	3.3 V	3.3 V	2.5	3.5		pF	
C _{io}	A port	3.3 V	3.3 V	7	7.5		pF	
	B port			9.5	10			

TIMING REQUIREMENTS

 T_A = 25°C, V_{CCA} = 1.2 V

			V _{CCB} = 1.2 V	V _{CCB} = 1.5 V	V _{CCB} = 1.8 V	V _{CCB} = 2.5 V	V _{CCB} = 3.3 V	UNIT	
			TYP	TYP	TYP	TYP	TYP		
Data rate	Command	Push-pull driving	60	80	120	120	120	Mbps	
		Open-drain driving	2	2	2	2	2		
	Clock	Push-pull driving	30	40	60	60	60	MHz	
	Data	Push-pull driving	60	80	120	120	120	Mbps	
t _w	Pulse duration	Push-pull driving	CLK	17	13	8	8	8	ns
		Open-drain driving	CMD	500	500	500	500	500	
	Push-pull driving	Data	17	13	8	8	8		
		CMD	17	13	8	8	8		

TIMING REQUIREMENTS

over recommended operating free-air temperature range, $V_{CCA} = 1.5 \text{ V} \pm 0.1 \text{ V}$ (unless otherwise noted)

			$V_{CCB} = 1.2 \text{ V}$	$V_{CCB} = 1.5 \text{ V} \pm 0.1 \text{ V}$		$V_{CCB} = 1.8 \text{ V} \pm 0.15 \text{ V}$		$V_{CCB} = 2.5 \text{ V} \pm 0.2 \text{ V}$		$V_{CCB} = 3.3 \text{ V} \pm 0.3 \text{ V}$		UNIT
			TYP	MIN	MAX	MIN	MAX	MIN	MAX	MIN	MAX	
Data rate	Command	Push-pull driving	60	80		120		120		120		Mbps
		Open-drain driving	2	2		2		2		2		
	Data	Push-pull driving	30	40		60		60		60		MHz
		Push-pull driving	60	80		120		120		120		
t_w	Pulse duration	Push-pull driving	17	13	8		8		8		ns	
		Open-drain driving	500	500	500		500		500			
		Push-pull driving	Data	17	13	8		8		8		
			CMD	17	13	8		8		8		

TIMING REQUIREMENTS

over recommended operating free-air temperature range, $V_{CCA} = 1.8 \text{ V} \pm 0.15 \text{ V}$ (unless otherwise noted)

			$V_{CCB} = 1.2 \text{ V}$	$V_{CCB} = 1.5 \text{ V} \pm 0.1 \text{ V}$		$V_{CCB} = 1.8 \text{ V} \pm 0.15 \text{ V}$		$V_{CCB} = 2.5 \text{ V} \pm 0.2 \text{ V}$		$V_{CCB} = 3.3 \text{ V} \pm 0.3 \text{ V}$		UNIT
			TYP	MIN	MAX	MIN	MAX	MIN	MAX	MIN	MAX	
Data rate	Command	Push-pull driving	60	80		120		120		120		Mbps
		Open-drain driving	2	2		2		2		2		
	Data	Push-pull driving	30	40		60		60		60		MHz
		Push-pull driving	60	80		120		120		120		
t_w	Pulse duration	Push-pull driving	17	13	8		8		8		ns	
		Open-drain driving	500	500	500		500		500			
		Push-pull driving	Data	17	13	8		8		8		
			CMD	17	13	8		8		8		

TIMING REQUIREMENTS

 over recommended operating free-air temperature range, $V_{CCA} = 2.5 \text{ V} \pm 0.2 \text{ V}$ (unless otherwise noted)

			$V_{CCB} = 1.2 \text{ V}$	$V_{CCB} = 1.5 \text{ V} \pm 0.1 \text{ V}$		$V_{CCB} = 1.8 \text{ V} \pm 0.15 \text{ V}$		$V_{CCB} = 2.5 \text{ V} \pm 0.2 \text{ V}$		$V_{CCB} = 3.3 \text{ V} \pm 0.3 \text{ V}$		UNIT
			TYP	MIN	MAX	MIN	MAX	MIN	MAX	MIN	MAX	
Data rate	Command	Push-pull driving	60	80		120		120		120		Mbps
		Open-drain driving	2	2		2		2		2		
	Data	Push-pull driving	30	40		60		60		60		MHz
		Push-pull driving	60	80		120		120		120		Mbps
t_w	Pulse duration	Push-pull driving	17	13	8		8		8		ns	
		Open-drain driving	500	500	500		500		500			
		Push-pull driving	Data	17	13	8		8		8		
			CMD	17	13	8		8		8		

TIMING REQUIREMENTS

 over recommended operating free-air temperature range, $V_{CCA} = 3.3 \text{ V} \pm 0.3 \text{ V}$ (unless otherwise noted)

			$V_{CCB} = 1.2 \text{ V}$	$V_{CCB} = 1.5 \text{ V} \pm 0.1 \text{ V}$		$V_{CCB} = 1.8 \text{ V} \pm 0.15 \text{ V}$		$V_{CCB} = 2.5 \text{ V} \pm 0.2 \text{ V}$		$V_{CCB} = 3.3 \text{ V} \pm 0.3 \text{ V}$		UNIT
			TYP	MIN	MAX	MIN	MAX	MIN	MAX	MIN	MAX	
Data rate	Command	Push-pull driving	60	80		120		120		120		Mbps
		Open-drain driving	2	2		2		2		2		
	Data	Push-pull driving	30	40		60		60		60		MHz
		Push-pull driving	60	80		120		120		120		Mbps
t_w	Pulse duration	Push-pull driving	17	13	8		8		8		ns	
		Open-drain driving	500	500	500		500		500			
		Push-pull driving	Data	17	13	8		8		8		
			CMD	17	13	8		8		8		

SWITCHING CHARACTERISTICS

 $T_A = 25^\circ\text{C}$, $V_{CCA} = 1.2\text{ V}$

PARAMETER	FROM (INPUT)	TO (OUTPUT)	TEST CONDITIONS	$V_{CCB} = 1.2\text{ V}$	$V_{CCB} = 1.5\text{ V}$	$V_{CCB} = 1.8\text{ V}$	$V_{CCB} = 2.5\text{ V}$	$V_{CCB} = 3.3\text{ V}$	UNIT
				TYP	TYP	TYP	TYP	TYP	
t_{PD}	CMDA	CMDB	Push-pull driving	5.9	4.8	4.4	4	4.46	ns
			Open-drain driving	238	214	192	159	140	
	CMDB	CMDA	Push-pull driving	5.6	4.8	4.4	4.1	4	
			Open-drain driving	227	201	176	137	114	
	CLKA	CLKB	Push-pull driving	5.5	4.1	3.6	3.2	3	
	DATA	DATB	Push-pull driving	5.8	4.8	4.4	4.2	6.8	
	DATB	DATA		5.6	4.8	4.4	4.1	4	
SEL	B-Port	Push-pull driving	13	11	10	9.4	9.1		
t_{rA}	A-port rise time		Push-pull driving	4.8	5.1	5.1	5.3	5.7	ns
t_{rB}	B-port rise time		Push-pull driving	6.1	3.8	2.9	1.9	1.5	
t_{rB}	CLKA	CLKB	Push-pull driving	5.2	3.4	2.6	1.7	1.3	
t_{fA}	A-port fall time		Push-pull driving	3.4	2.8	2.6	2.6	2.6	
t_{fB}	B-port fall time		Push-pull driving	4.2	3	2.3	1.7	1.5	
t_{fB}	CLKA	CLKB	Push-pull driving	3.1	2.1	1.6	1.2	1	
$t_{sk(O)}$	ChA-to-ChB skew		Push-pull driving	0.4	0.4	0.3	0.4	0.4	ns
	ChB-to-ChA skew		Push-pull driving	0.3	0.3	0.3	0.3	0.4	
	Channel-to-Clock skew		Push-pull driving	1.68	1.5	1.5	1.5	1.7	
Max data rate	Command		Push-pull driving	60	80	120	120	120	Mbps
			Open-drain driving	2	2	2	2	2	
	Clock		Push-pull driving	30	40	60	60	60	MHz
	Data		Push-pull driving	60	80	120	120	120	Mbps

SWITCHING CHARACTERISTICS

 over operating free-air temperature range, $V_{CCA} = 1.5 \text{ V} \pm 0.1 \text{ V}$ (unless otherwise noted)

PARAMETER	FROM (INPUT)	TO (OUTPUT)	TEST CONDITIONS	$V_{CCB} = 1.2 \text{ V}$		$V_{CCB} = 1.5 \text{ V} \pm 0.1 \text{ V}$		$V_{CCB} = 1.8 \text{ V} \pm 0.15 \text{ V}$		$V_{CCB} = 2.5 \text{ V} \pm 0.2 \text{ V}$		$V_{CCB} = 3.3 \text{ V} \pm 0.3 \text{ V}$		UNIT
				TYP	MIN	MAX	MIN	MAX	MIN	MAX	MIN	MAX		
t_{PD}	CMDA	CMDB	Push-pull driving	5.1		13		9		8		7.5	ns	
			Open-drain driving	210		777		756		684		758		
	CMDB	CMDA	Push-pull driving	4.5		10.6		9.2		8.5		8.2		
			Open-drain driving	200		616		560		433		375		
	CLKA	CLKB	Push-pull driving	4.7		13.1		9.8		6		5.2		
	DATA	DATB	Push-pull driving	5.1		13		9		8		7.8		
	DATB	DATA		4.5		11		9.3		8.8		8.4		
SEL	B-Port	Push-pull driving	9.5		26		21		19		18			
t_{rA}	A-port rise time		Push-pull driving	2.7	1.5	5.8	1.7	5.9	1.7	6	1.8	6.1	ns	
t_{rB}	B-port rise time		Push-pull driving	3.3	1.7	8.2	1.3	6.6	1	4.3	0.8	2.9		
t_{rB}	CLKA	CLKB	Push-pull driving	5.2	1.7	6.4	1.3	4.9	0.9	3.2	0.8	2.5	ns	
t_{fA}	A-port fall time		Push-pull driving	2.4	1	3.9	0.9	3.4	0.9	3.2	1.3	3.3		
t_{fB}	B-port fall time		Push-pull driving	3.7	1.1	6.3	0.9	5.2	0.6	3.9	0.6	3.2	ns	
t_{fB}	CLKA	CLKB	Push-pull driving	3.1	0.9	4.1	0.8	3.2	0.5	2.2	0.5	1.9		
$t_{sk(O)}$	ChA-to-ChB skew		Push-pull driving	0.32		0.47		0.58		0.63		0.63	ns	
	ChB-to-ChA skew		Push-pull driving	0.27		0.24		0.23		0.22		0.22		
	Channel-to-Clock skew		Push-pull driving	1.47		1.66		1.68		1.82		1.77		
Max data rate	Command		Push-pull driving	60		80		120		120		120	Mbps	
			Open-drain driving	2		2		2		2		2		
	Clock		Push-pull driving	30		40		60		60		60	MHz	
	Data		Push-pull driving	60		80		120		120		120	Mbps	

SWITCHING CHARACTERISTICS

over operating free-air temperature range, $V_{CCA} = 1.8 \text{ V} \pm 0.15 \text{ V}$ (unless otherwise noted)

PARAMETER	FROM (INPUT)	TO (OUTPUT)	TEST CONDITIONS	$V_{CCB} = 1.2 \text{ V}$		$V_{CCB} = 1.5 \text{ V} \pm 0.1 \text{ V}$		$V_{CCB} = 1.8 \text{ V} \pm 0.15 \text{ V}$		$V_{CCB} = 2.5 \text{ V} \pm 0.2 \text{ V}$		$V_{CCB} = 3.3 \text{ V} \pm 0.3 \text{ V}$		UNIT
				TYP	MIN	MAX	MIN	MAX	MIN	MAX	MIN	MAX		
t_{PD}	CMDA	CMDB	Push-pull driving	4.8		12		8		6		5.7	ns	
			Open-drain driving	183		726		715		686		780		
	CMDB	CMDA	Push-pull driving	4		9		7		6.4		6		
			Open-drain driving	175		565		563		441		392		
	CLKA	CLKB	Push-pull driving	4.5		13		9		5.4		4.5		
	DATA	DATB	Push-pull driving	4.7		12		8.4		6		5.8		
	DATB	DATA		4.1		9		7.5		6.4		6.3		
SEL	B-Port	Push-pull driving	8.2		22		17		14.8		14			
t_{rA}	A-port rise time		Push-pull driving	2	1.1	4	1.1	4.3	1.2	4.5	1.3	4.6	ns	
t_{rB}	B-port rise time		Push-pull driving	6.2	1.7	7.9	1.2	6.2	1	4.3	0.8	3.1		
t_{rB}	CLKA	CLKB	Push-pull driving	5.2	1.7	6.4	1.3	4.9	0.9	3.2	0.8	2.5	ns	
t_{fA}	A-port fall time		Push-pull driving	1.8	0.8	3.2	0.7	2.8	0.7	1.7	0.7	2.6		
t_{fB}	B-port fall time		Push-pull driving	3.5	1	5.6	0.9	3.5	0.6	1.9	0.6	3	ns	
t_{fB}	CLKA	CLKB	Push-pull driving	3.1	0.9	4.1	0.8	3.2	0.5	2.2	0.5	1.9		
$t_{sk(O)}$	ChA-to-ChB skew		Push-pull driving	0.33		0.45		0.48		0.53		0.67	ns	
	ChB-to-ChA skew		Push-pull driving	0.28		0.24		0.23		0.23		0.22		
	Channel-to-Clock skew		Push-pull driving	1.51		1.58		1.46		1.56		1.48		
Max data rate	Command		Push-pull driving	60		80		120		120		120	Mbps	
			Open-drain driving	2		2		2		2		2		
	Clock		Push-pull driving	30		40		60		60		60	MHz	
	Data		Push-pull driving	60		80		120		120		120	Mbps	

SWITCHING CHARACTERISTICS

 over operating free-air temperature range, $V_{CCA} = 2.5 \text{ V} \pm 0.2 \text{ V}$ (unless otherwise noted)

PARAMETER	FROM (INPUT)	TO (OUTPUT)	TEST CONDITIONS	$V_{CCB} = 1.2 \text{ V}$		$V_{CCB} = 1.5 \text{ V} \pm 0.1 \text{ V}$		$V_{CCB} = 1.8 \text{ V} \pm 0.15 \text{ V}$		$V_{CCB} = 2.5 \text{ V} \pm 0.2 \text{ V}$		$V_{CCB} = 3.3 \text{ V} \pm 0.3 \text{ V}$		UNIT
				TYP	MIN	MAX	MIN	MAX	MIN	MAX	MIN	MAX		
t_{PD}	CMDA	CMDB	Push-pull driving	4.4		11		7.4		4.4		3.8	ns	
			Open-drain driving	143		544		596		605		669		
	CMDB	CMDA	Push-pull driving	3.8		7.6		5.5		4.2		3.7		
			Open-drain driving	137		434		444		414		372		
	CLKA	CLKB	Push-pull driving	4.1		12		8		4.8		3.8		
	DATA	DATB	Push-pull driving	4.4		11		7		4.5		3.8		
	DATB	DATA		4.4		8		5.5		4.1		3.7		
SEL	B-Port	Push-pull driving	7		18		13		10.5		9			
t_{rA}	A-port rise time		Push-pull driving	1.4	0.75	2.2	0.74	2.2	1.06	2.6	0.7	2.8	ns	
t_{rB}	B-port rise time		Push-pull driving	6.3	1.91	7.7	1.34	6.1	0.95	4.2	0.83	3.2		
t_{rB}	CLKA	CLKB	Push-pull driving	5.2	1.67	6.4	1.27	4.9	0.9	3.2	0.76	2.6	ns	
t_{fA}	A-port fall time		Push-pull driving	1.1	0.58	1.9	0.58	2	0.61	1.9	0.57	1.9		
t_{fB}	B-port fall time		Push-pull driving	3.6	1.04	5.4	0.87	4.3	0.66	3.4	0.57	3	ns	
t_{fB}	CLKA	CLKB	Push-pull driving	3.1	0.92	4.2	0.79	3.2	0.56	2.2	0.49	1.9		
$t_{sk(O)}$	ChA-to-ChB skew		Push-pull driving	0.41		0.43		0.39		0.59		0.68	ns	
	ChB-to-ChA skew		Push-pull driving	0.41		0.24		0.2		0.19		0.18		
	Channel-to-Clock skew		Push-pull driving	2.11		1.47		1.3		1.25		1.21		
Max data rate	Command		Push-pull driving	60		80		120		120		120	Mbps	
			Open-drain driving	2		2		2		2		2		
	Clock		Push-pull driving	30		40		60		60		60	MHz	
	Data		Push-pull driving	60		80		120		120		120	Mbps	

SWITCHING CHARACTERISTICS

over operating free-air temperature range, $V_{CCA} = 3.3 \text{ V} \pm 0.3 \text{ V}$ (unless otherwise noted)

PARAMETER	FROM (INPUT)	TO (OUTPUT)	TEST CONDITIONS	$V_{CCB} = 1.2 \text{ V}$		$V_{CCB} = 1.5 \text{ V} \pm 0.1 \text{ V}$		$V_{CCB} = 1.8 \text{ V} \pm 0.15 \text{ V}$		$V_{CCB} = 2.5 \text{ V} \pm 0.2 \text{ V}$		$V_{CCB} = 3.3 \text{ V} \pm 0.3 \text{ V}$		UNIT
				TYP	MIN	MAX	MIN	MAX	MIN	MAX	MIN	MAX	MIN	
t_{PD}	CMDA	CMDB	Push-pull driving	4.4		11		7		4.1		3.3	ns	
			Open-drain driving	116		432		477		506		533		
	CMDB	CMDA	Push-pull driving	4.2		7.5		5.4		3.8		3		
			Open-drain driving	112		349		363		347		324		
	CLKA	CLKB	Push-pull driving	4.1		12		7.8		4.4		3.5		
	DATA	DATB	Push-pull driving	4.3		11		6.8		4		3.8		
	DATB	DATA		7.9		7.8		5.4		3.4		3		
SEL	B-Port	Push-pull driving	6.4		16		11.5		8.8		7.6			
t_{rA}	A-port rise time		Push-pull driving	1.1	0.57	1.7	0.57	1.8	0.56	1.7	0.53	1.8	ns	
t_{rB}	B-port rise time		Push-pull driving	6.2	1.96	7.7	1.43	6.1	0.95	4.2	0.71	3.1		
t_{fB}	CLKA	CLKB	Push-pull driving	5.2	1.67	6.4	1.26	4.9	0.91	3.3	0.76	2.5	ns	
t_{fA}	A-port fall time		Push-pull driving	1	0.53	1.6	0.52	1.6	0.53	1.6	0.56	1.6		
t_{fB}	B-port fall time		Push-pull driving	3.4	0.95	5.2	0.8	4.1	0.63	3.2	0.58	2.9	ns	
t_{fB}	CLKA	CLKB	Push-pull driving	3.1	0.92	4.1	0.79	3.2	0.56	2.2	0.49	1.9		
$t_{sk(O)}$	ChA-to-ChB skew		Push-pull driving	0.39		0.36		0.39		0.57		0.65	ns	
	ChB-to-ChA skew		Push-pull driving	0.45		0.3		0.19		0.19		0.18		
	Channel-to-Clock skew		Push-pull driving	1.7		1.61		1.34		1.22		1.14		
Max data rate	Command		Push-pull driving	60		80		120		120		120	Mbps	
			Open-drain driving	2		2		2		2		2		
	Clock		Push-pull driving	30		40		60		60		60	MHz	
	Data		Push-pull driving	60		80		120		120		120	Mbps	

OPERATING CHARACTERISTICS

over operating free-air temperature range (unless otherwise noted)

PARAMETER			TEST CONDITIONS	V_{CCA}					UNIT
				1.2 V	1.5 V	1.8 V	2.5 V	3.3 V	
				V_{CCB}					
				1.2 V	1.5 V	1.8 V	2.5 V	3.3 V	
				TYP	TYP	TYP	TYP	TYP	
Data and CMD	C_{pdA}	A-port input, B-port output	$C_L = 0$, $f = 10 \text{ MHz}$, $t_r = t_f = 1 \text{ ns}$, OE = outputs enabled	14.5	12.9	12.1	13.4	15	pF
		B-port input, A-port output		20.7	20.7	21	22	23.2	
	C_{pdB}	A-port input, B-port output		23.2	23.4	23.6	24.5	25.5	
		B-port input, A-port output		14.1	12.2	11.5	12.9	14.4	
		A-port input, B-port output		0.1	0.1	0.1	0.1	0.1	
Clock	C_{pdA}	A-port input, B-port output	$C_L = 0$, $f = 10 \text{ MHz}$, $t_r = t_f = 1 \text{ ns}$, OE = outputs enabled	0.4	0.4	0.4	0.5	0.7	pF
	C_{pdB}	B-port input, A-port output		14	13.9	13.8	13.8	13.7	

POWER-UP CONSIDERATIONS

The following power-up sequence for this TXS02612 SDIO port expander with voltage-level translator should be followed to ensure proper operation and to avoid any unnecessary excessive supply current, bus contention, oscillations, or other anomalies caused by improperly biased device pins. The following power-up sequence should be used to safe-guard against these problems:

1. Connect the ground pin of the device first before any power-supply voltage is applied.
2. Connect and power up V_{CCA} , which internally powers up the SEL control logic of the TXS02612.
3. Depending on the port to be chosen, the SEL pin can be high or low. If SEL high is needed (i.e., A port to B₁ port), ramp the SEL pin with the V_{CCA} power supply. Otherwise, keep SEL Low.
4. Apply V_{CCB0} and V_{CCB1} only after the V_{CCA} power supply is applied.

PARAMETER MEASUREMENT INFORMATION

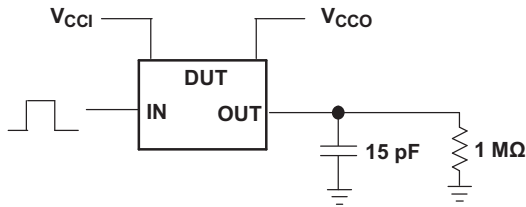

DATA RATE, PULSE DURATION, PROPAGATION DELAY, ENABLE/DISABLE OUTPUT RISE AND FALL TIME MEASUREMENT USING A PUSH-PULL DRIVER

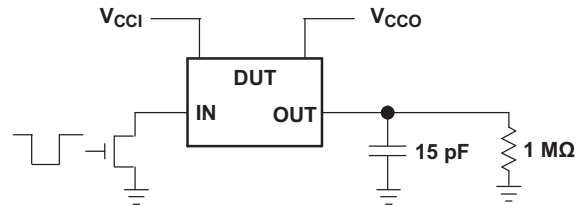

DATA RATE, PULSE DURATION, PROPAGATION DELAY, OUTPUT RISE AND FALL TIME MEASUREMENT USING AN OPEN-DRAIN DRIVER

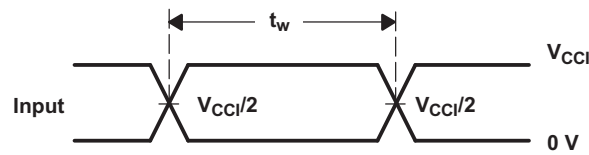

VOLTAGE WAVEFORMS PULSE DURATION

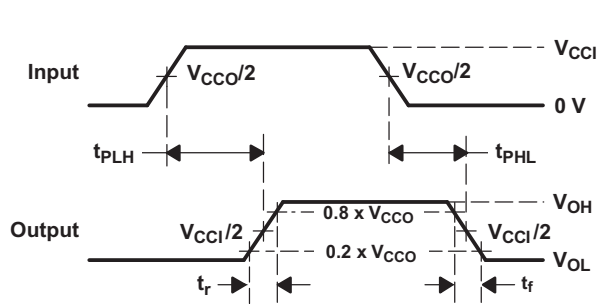

VOLTAGE WAVEFORMS PROPAGATION DELAY TIMES

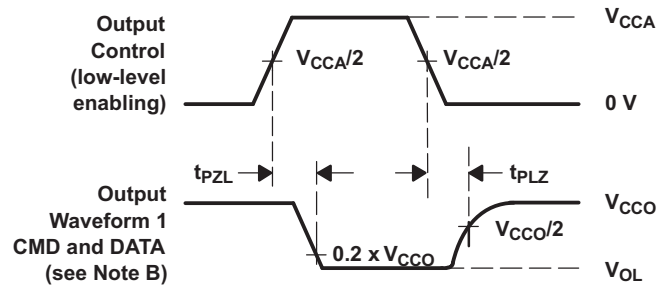

VOLTAGE WAVEFORMS ENABLE AND DISABLE TIMES

- NOTES:
- A. C_L includes probe and jig capacitance.
 - B. Waveform 1 is for an output with internal conditions such that the output is low except when disabled by the output control. Waveform 2 is for an output with internal conditions such that the output is high, except when disabled by the output control.
 - C. All input pulses are supplied by generators having the following characteristics: PRR = 10 MHz, $Z_O = 50\Omega$, $dv/dt \geq 1$ V/ns.
 - D. The outputs are measured one at a time, with one transition per measurement.
 - E. t_{PLZ} and t_{HZ} are the same as t_{dis} .
 - F. t_{PZL} and t_{ZH} are the same as t_{en} .
 - G. t_{PLH} and t_{HL} are the same as t_{cd} .
 - H. V_{CCI} is the V_{CC} associated with the input port.
 - I. V_{CCO} is the V_{CC} associated with the output port.
 - J. All parameters and waveforms are not applicable to all devices.

Figure 1. Load Circuit and Voltage Waveforms

PACKAGING INFORMATION

Orderable Device	Status (1)	Package Type	Package Drawing	Pins	Package Qty	Eco Plan (2)	Lead/Ball Finish	MSL Peak Temp (3)	Op Temp (°C)	Device Marking (4/5)	Samples
TXS02612RTWR	ACTIVE	WQFN	RTW	24	3000	Green (RoHS & no Sb/Br)	CU NIPDAU	Level-2-260C-1 YEAR	-40 to 85	YJ612	Samples
TXS02612ZQSR	ACTIVE	BGA MICROSTAR JUNIOR	ZQS	24	2500	Green (RoHS & no Sb/Br)	SNAGCU	Level-1-260C-UNLIM	-40 to 85	YJ612	Samples

(1) The marketing status values are defined as follows:

ACTIVE: Product device recommended for new designs.

LIFEBUY: TI has announced that the device will be discontinued, and a lifetime-buy period is in effect.

NRND: Not recommended for new designs. Device is in production to support existing customers, but TI does not recommend using this part in a new design.

PREVIEW: Device has been announced but is not in production. Samples may or may not be available.

OBSOLETE: TI has discontinued the production of the device.

(2) Eco Plan - The planned eco-friendly classification: Pb-Free (RoHS), Pb-Free (RoHS Exempt), or Green (RoHS & no Sb/Br) - please check <http://www.ti.com/productcontent> for the latest availability information and additional product content details.

TBD: The Pb-Free/Green conversion plan has not been defined.

Pb-Free (RoHS): TI's terms "Lead-Free" or "Pb-Free" mean semiconductor products that are compatible with the current RoHS requirements for all 6 substances, including the requirement that lead not exceed 0.1% by weight in homogeneous materials. Where designed to be soldered at high temperatures, TI Pb-Free products are suitable for use in specified lead-free processes.

Pb-Free (RoHS Exempt): This component has a RoHS exemption for either 1) lead-based flip-chip solder bumps used between the die and package, or 2) lead-based die adhesive used between the die and leadframe. The component is otherwise considered Pb-Free (RoHS compatible) as defined above.

Green (RoHS & no Sb/Br): TI defines "Green" to mean Pb-Free (RoHS compatible), and free of Bromine (Br) and Antimony (Sb) based flame retardants (Br or Sb do not exceed 0.1% by weight in homogeneous material)

(3) MSL, Peak Temp. -- The Moisture Sensitivity Level rating according to the JEDEC industry standard classifications, and peak solder temperature.

(4) There may be additional marking, which relates to the logo, the lot trace code information, or the environmental category on the device.

(5) Multiple Device Markings will be inside parentheses. Only one Device Marking contained in parentheses and separated by a "~" will appear on a device. If a line is indented then it is a continuation of the previous line and the two combined represent the entire Device Marking for that device.

Important Information and Disclaimer: The information provided on this page represents TI's knowledge and belief as of the date that it is provided. TI bases its knowledge and belief on information provided by third parties, and makes no representation or warranty as to the accuracy of such information. Efforts are underway to better integrate information from third parties. TI has taken and continues to take reasonable steps to provide representative and accurate information but may not have conducted destructive testing or chemical analysis on incoming materials and chemicals. TI and TI suppliers consider certain information to be proprietary, and thus CAS numbers and other limited information may not be available for release.

In no event shall TI's liability arising out of such information exceed the total purchase price of the TI part(s) at issue in this document sold by TI to Customer on an annual basis.

TAPE AND REEL INFORMATION

QUADRANT ASSIGNMENTS FOR PIN 1 ORIENTATION IN TAPE

*All dimensions are nominal

Device	Package Type	Package Drawing	Pins	SPQ	Reel Diameter (mm)	Reel Width W1 (mm)	A0 (mm)	B0 (mm)	K0 (mm)	P1 (mm)	W (mm)	Pin1 Quadrant
TXS02612RTWR	WQFN	RTW	24	3000	330.0	12.4	4.25	4.25	1.15	8.0	12.0	Q2
TXS02612ZQSR	BGA MICROSTAR JUNIOR	ZQS	24	2500	330.0	12.4	3.3	3.3	1.6	8.0	12.0	Q1

TAPE AND REEL BOX DIMENSIONS

*All dimensions are nominal

Device	Package Type	Package Drawing	Pins	SPQ	Length (mm)	Width (mm)	Height (mm)
TXS02612RTWR	WQFN	RTW	24	3000	367.0	367.0	35.0
TXS02612ZQSR	BGA MICROSTAR JUNIOR	ZQS	24	2500	338.1	338.1	20.6

ZQS (S-PBGA-N24)

PLASTIC BALL GRID ARRAY

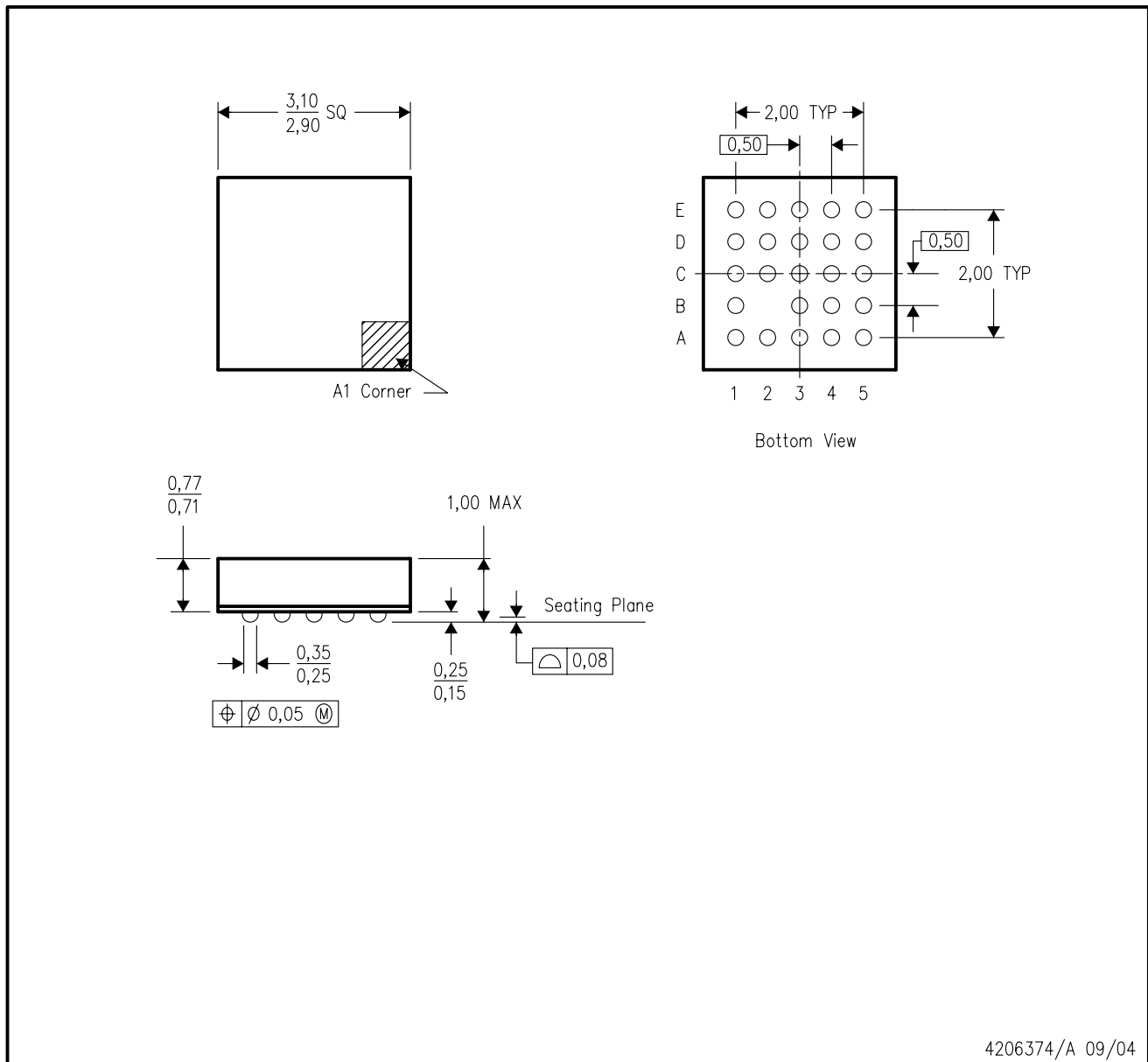

- NOTES:
- A. All linear dimensions are in millimeters.
 - B. This drawing is subject to change without notice.
 - C. Falls within JEDEC MO-225
 - D. This package is lead-free.

RTW (S-PWQFN-N24)

PLASTIC QUAD FLATPACK NO-LEAD

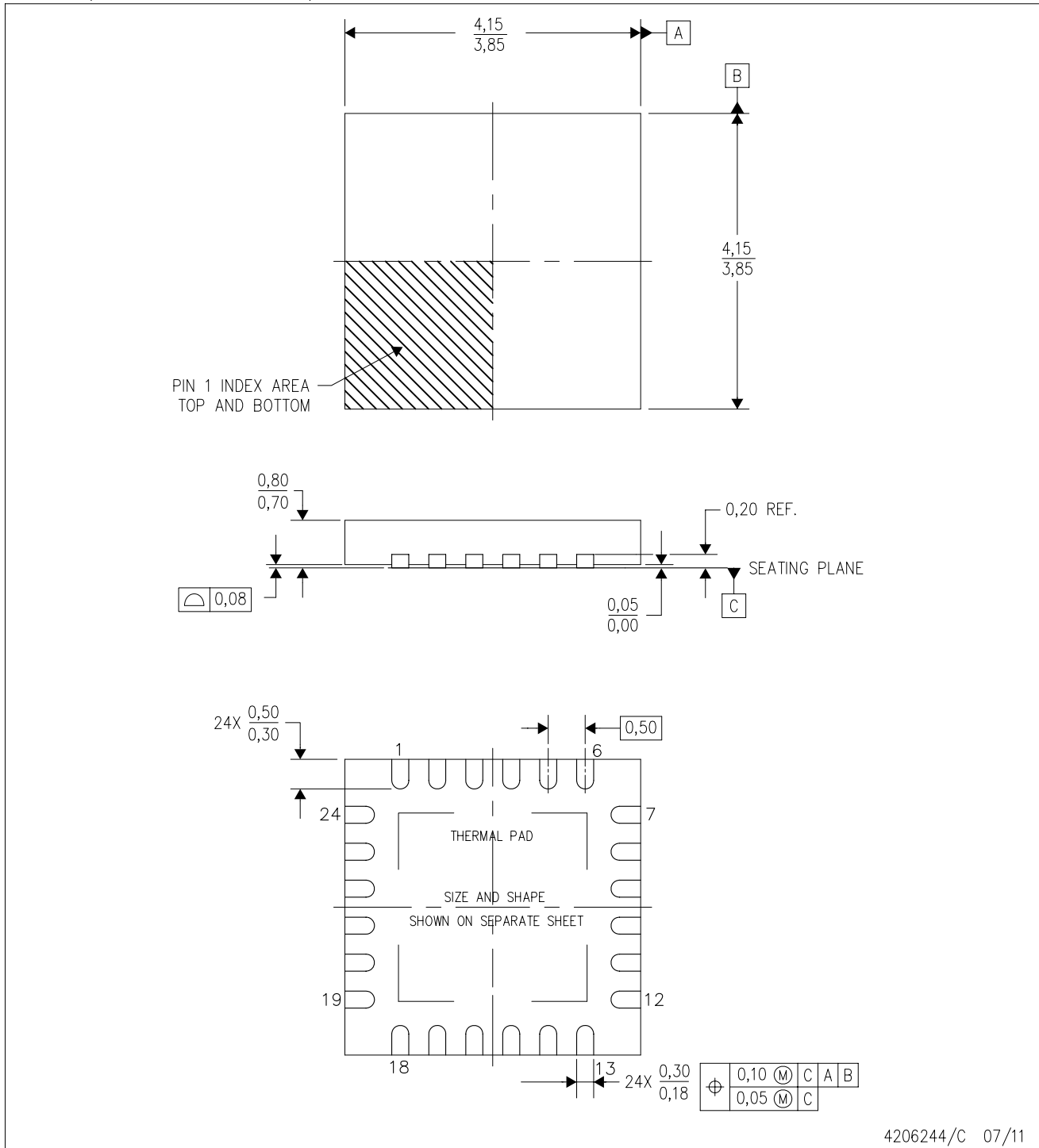

4206244/C 07/11

- NOTES:
- All linear dimensions are in millimeters. Dimensioning and tolerancing per ASME Y14.5M-1994.
 - This drawing is subject to change without notice.
 - Quad Flatpack, No-Leads (QFN) package configuration.
 - The package thermal pad must be soldered to the board for thermal and mechanical performance.
 - See the additional figure in the Product Data Sheet for details regarding the exposed thermal pad features and dimensions.
 - Falls within JEDEC MO-220.

THERMAL INFORMATION

This package incorporates an exposed thermal pad that is designed to be attached directly to an external heatsink. The thermal pad must be soldered directly to the printed circuit board (PCB). After soldering, the PCB can be used as a heatsink. In addition, through the use of thermal vias, the thermal pad can be attached directly to the appropriate copper plane shown in the electrical schematic for the device, or alternatively, can be attached to a special heatsink structure designed into the PCB. This design optimizes the heat transfer from the integrated circuit (IC).

For information on the Quad Flatpack No-Lead (QFN) package and its advantages, refer to Application Report, QFN/SON PCB Attachment, Texas Instruments Literature No. SLUA271. This document is available at www.ti.com.

The exposed thermal pad dimensions for this package are shown in the following illustration.

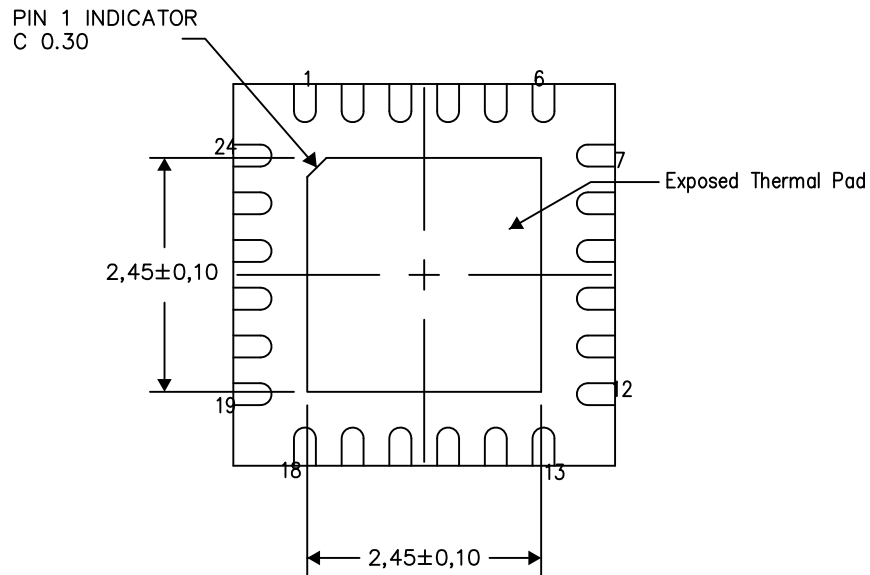

Bottom View
Exposed Thermal Pad Dimensions

4206249-3/N 02/14

NOTES: A. All linear dimensions are in millimeters

RTW (S-PWQFN-N24)

PLASTIC QUAD FLATPACK NO-LEAD

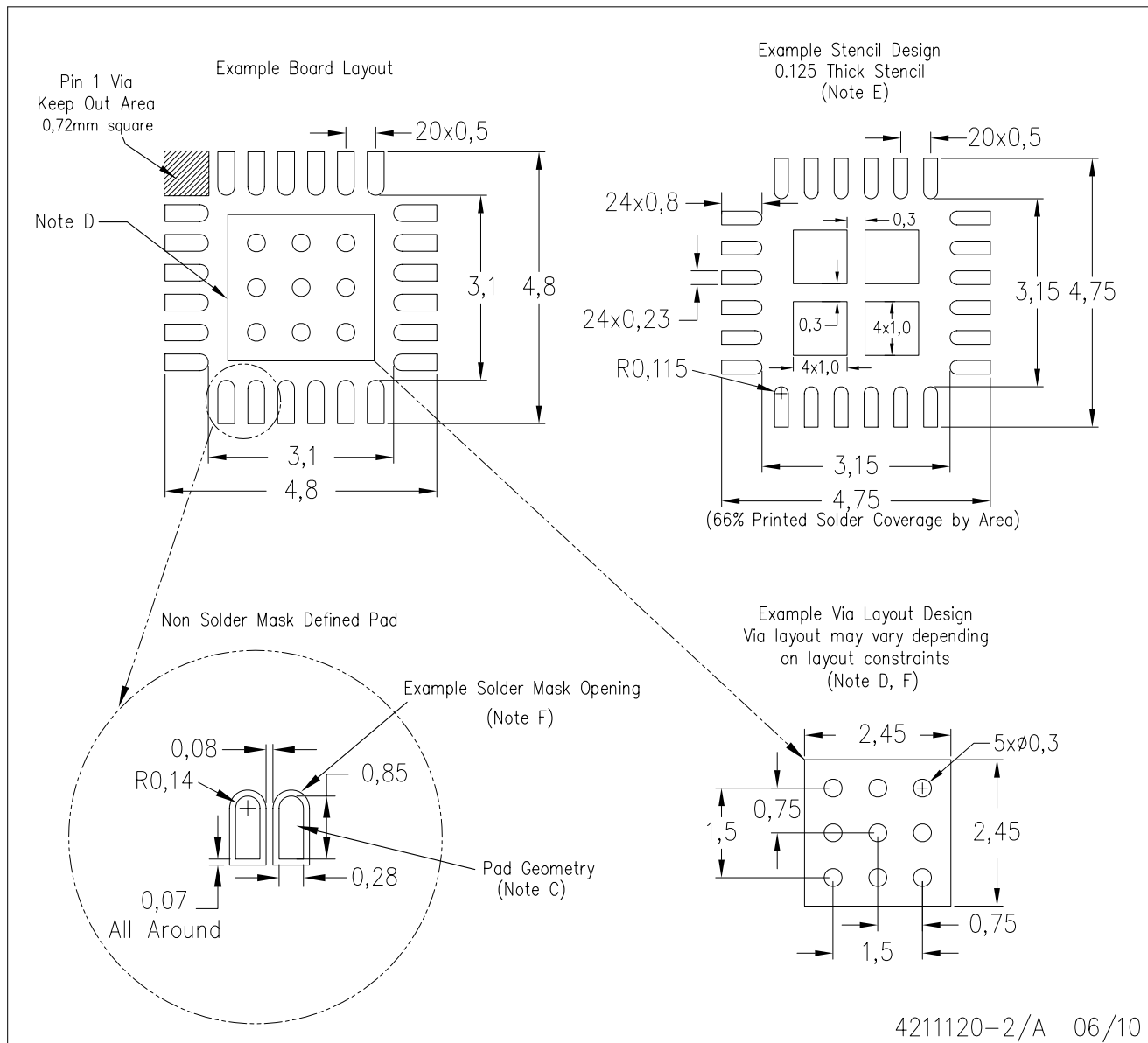

4211120-2/A 06/10

- NOTES:
- All linear dimensions are in millimeters.
 - This drawing is subject to change without notice.
 - Publication IPC-7351 is recommended for alternate designs.
 - This package is designed to be soldered to a thermal pad on the board. Refer to Application Note, Quad Flat-Pack Packages, Texas Instruments Literature No. SLUA271, and also the Product Data Sheets for specific thermal information, via requirements, and recommended board layout. These documents are available at www.ti.com <<http://www.ti.com>>.
 - Laser cutting apertures with trapezoidal walls and also rounding corners will offer better paste release. Customers should contact their board assembly site for stencil design recommendations. Refer to IPC 7525 for stencil design considerations.
 - Customers should contact their board fabrication site for recommended solder mask tolerances and via tenting recommendations for vias placed in the thermal pad.

IMPORTANT NOTICE

Texas Instruments Incorporated and its subsidiaries (TI) reserve the right to make corrections, enhancements, improvements and other changes to its semiconductor products and services per JESD46, latest issue, and to discontinue any product or service per JESD48, latest issue. Buyers should obtain the latest relevant information before placing orders and should verify that such information is current and complete. All semiconductor products (also referred to herein as "components") are sold subject to TI's terms and conditions of sale supplied at the time of order acknowledgment.

TI warrants performance of its components to the specifications applicable at the time of sale, in accordance with the warranty in TI's terms and conditions of sale of semiconductor products. Testing and other quality control techniques are used to the extent TI deems necessary to support this warranty. Except where mandated by applicable law, testing of all parameters of each component is not necessarily performed.

TI assumes no liability for applications assistance or the design of Buyers' products. Buyers are responsible for their products and applications using TI components. To minimize the risks associated with Buyers' products and applications, Buyers should provide adequate design and operating safeguards.

TI does not warrant or represent that any license, either express or implied, is granted under any patent right, copyright, mask work right, or other intellectual property right relating to any combination, machine, or process in which TI components or services are used. Information published by TI regarding third-party products or services does not constitute a license to use such products or services or a warranty or endorsement thereof. Use of such information may require a license from a third party under the patents or other intellectual property of the third party, or a license from TI under the patents or other intellectual property of TI.

Reproduction of significant portions of TI information in TI data books or data sheets is permissible only if reproduction is without alteration and is accompanied by all associated warranties, conditions, limitations, and notices. TI is not responsible or liable for such altered documentation. Information of third parties may be subject to additional restrictions.

Resale of TI components or services with statements different from or beyond the parameters stated by TI for that component or service voids all express and any implied warranties for the associated TI component or service and is an unfair and deceptive business practice. TI is not responsible or liable for any such statements.

Buyer acknowledges and agrees that it is solely responsible for compliance with all legal, regulatory and safety-related requirements concerning its products, and any use of TI components in its applications, notwithstanding any applications-related information or support that may be provided by TI. Buyer represents and agrees that it has all the necessary expertise to create and implement safeguards which anticipate dangerous consequences of failures, monitor failures and their consequences, lessen the likelihood of failures that might cause harm and take appropriate remedial actions. Buyer will fully indemnify TI and its representatives against any damages arising out of the use of any TI components in safety-critical applications.

In some cases, TI components may be promoted specifically to facilitate safety-related applications. With such components, TI's goal is to help enable customers to design and create their own end-product solutions that meet applicable functional safety standards and requirements. Nonetheless, such components are subject to these terms.

No TI components are authorized for use in FDA Class III (or similar life-critical medical equipment) unless authorized officers of the parties have executed a special agreement specifically governing such use.

Only those TI components which TI has specifically designated as military grade or "enhanced plastic" are designed and intended for use in military/aerospace applications or environments. Buyer acknowledges and agrees that any military or aerospace use of TI components which have **not** been so designated is solely at the Buyer's risk, and that Buyer is solely responsible for compliance with all legal and regulatory requirements in connection with such use.

TI has specifically designated certain components as meeting ISO/TS16949 requirements, mainly for automotive use. In any case of use of non-designated products, TI will not be responsible for any failure to meet ISO/TS16949.

Products

Audio	www.ti.com/audio
Amplifiers	amplifier.ti.com
Data Converters	dataconverter.ti.com
DLP® Products	www.dlp.com
DSP	dsp.ti.com
Clocks and Timers	www.ti.com/clocks
Interface	interface.ti.com
Logic	logic.ti.com
Power Mgmt	power.ti.com
Microcontrollers	microcontroller.ti.com
RFID	www.ti-rfid.com
OMAP Applications Processors	www.ti.com/omap
Wireless Connectivity	www.ti.com/wirelessconnectivity

Applications

Automotive and Transportation	www.ti.com/automotive
Communications and Telecom	www.ti.com/communications
Computers and Peripherals	www.ti.com/computers
Consumer Electronics	www.ti.com/consumer-apps
Energy and Lighting	www.ti.com/energy
Industrial	www.ti.com/industrial
Medical	www.ti.com/medical
Security	www.ti.com/security
Space, Avionics and Defense	www.ti.com/space-avionics-defense
Video and Imaging	www.ti.com/video

TI E2E Community

e2e.ti.com