

TXS0104E-Q1 4-Bit Bidirectional Voltage-Level Translator for Open-Drain and Push-Pull Applications

1 Features

- Qualified for Automotive Applications
- AEC-Q100 Qualified With the Following Results:
 - Device Temperature Grade 1: –40°C to 125°C Ambient Operating Temperature Range
 - Device HBM ESD Classification Level 2
 - Device CDM ESD Classification Level C6
- No Direction-Control Signal Required
- Maximum Data Rates
 - 24 Mbps Maximum (Push Pull)
 - 2 Mbps (Open Drain)
- 1.65 V to 3.6 V on A port and 2.3 V to 5.5 V on B port ($V_{CCA} \leq V_{CCB}$)
- No Power-Supply Sequencing Required— V_{CCA} or V_{CCB} Can Be Ramped First
- ESD Protection Exceeds JESD 22
 - A Port
 - 2000-V Human-Body Model (A114-B)
 - 1000-V Charged-Device Model (C101)
 - B Port
 - 15-kV Human-Body Model (A114-B)
 - 1000-V Charged-Device Model (C101)
- IEC 61000-4-2 ESD (B Port)
 - ±8-kV Contact Discharge
 - ±10-kV Air-Gap Discharge

2 Applications

- Automotive infotainment, advance driver assistance systems (ADAS)
- Isolates and Level Translates Between Main Processor and Peripheral Modules
- I²C or 1-Wire Voltage-Level Translation

3 Description

The TXS0104E-Q1 device connects an incompatible logic communication from chip-to-chip due to voltage mismatch. This auto-direction translator can be conveniently used to bridge the gap without the need of direction control from the host. Each channel can be mixed and matched with different output types (open-drain or push-pull) and mixed data flows (transmit or receive) without intervention from the host. This 4-bit noninverting translator uses two separate configurable power-supply rails. The A and B ports are designed to track V_{CCA} and V_{CCB} respectively. The V_{CCB} pin accepts any supply voltage from 2.3 V to 5.5 V while the V_{CCA} pin accepts any supply voltage from 1.65 V to 3.6 V such that V_{CCA} is less than or equal to V_{CCB} . This tracking allows for low-voltage bidirectional translation between any of the 1.8-V, 2.5-V, 3.3-V, and 5-V voltage nodes.

When the output-enable (OE) input is low, all outputs are placed in the high-impedance state.

The TXS0104E-Q1 device is designed so that the OE input circuit is supplied by V_{CCA} .

To ensure the high-impedance state during power up or power down, the OE pin must be tied to the GND pin through a pulldown resistor; the minimum value of the resistor is determined by the current-sourcing capability of the driver.

Device Information⁽¹⁾

PART NUMBER	PACKAGE	BODY SIZE (NOM)
TXS0104E-Q1	TSSOP (14)	5.00 mm × 4.40 mm

(1) For all available packages, see the orderable addendum at the end of the datasheet.

Transfer Characteristics of an N-Channel Transistor

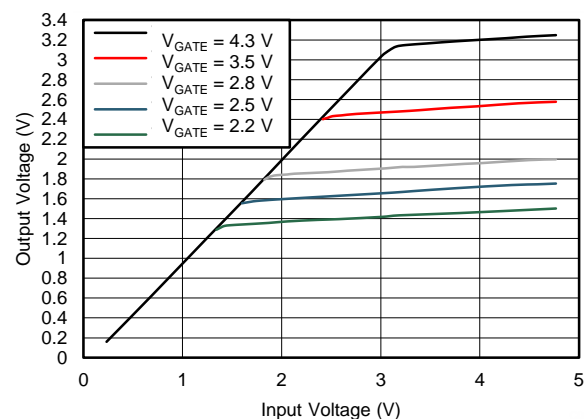

Table of Contents

1 Features	1	7.1 Load Circuits	11
2 Applications	1	7.2 Voltage Waveforms	12
3 Description	1	8 Detailed Description	13
4 Revision History	2	8.1 Overview	13
5 Pin Configuration and Functions	3	8.2 Functional Block Diagram	13
6 Specifications	4	8.3 Feature Description	14
6.1 Absolute Maximum Ratings	4	8.4 Device Functional Modes	14
6.2 Handling Ratings	4	9 Application and Implementation	15
6.3 Recommended Operating Conditions	5	9.1 Application Information	15
6.4 Thermal Information	5	9.2 Typical Application	15
6.5 Electrical Characteristics	6	10 Power Supply Recommendations	16
6.6 Timing Requirements— $V_{CCA} = 1.8\text{ V} \pm 0.15\text{ V}$	6	11 Layout	17
6.7 Timing Requirements— $V_{CCA} = 2.5\text{ V} \pm 0.2\text{ V}$	6	11.1 Layout Guidelines	17
6.8 Timing Requirements— $V_{CCA} = 3.3\text{ V} \pm 0.3\text{ V}$	7	11.2 Layout Example	17
6.9 Switching Characteristics— $V_{CCA} = 1.8\text{ V} \pm 0.15\text{ V}$...	7	12 Device and Documentation Support	18
6.10 Switching Characteristics— $V_{CCA} = 2.5\text{ V} \pm 0.2\text{ V}$...	8	12.1 Trademarks	18
6.11 Switching Characteristics— $V_{CCA} = 3.3\text{ V} \pm 0.3\text{ V}$...	9	12.2 Electrostatic Discharge Caution	18
6.12 Typical Characteristics	10	12.3 Glossary	18
7 Parameter Measurement Information	11	13 Mechanical, Packaging, and Orderable Information	18

4 Revision History

Changes from Revision A (April 2014) to Revision B

Page

• Changed device status from <i>Product Preview</i> to <i>Production Data</i>	1
---	---

5 Pin Configuration and Functions

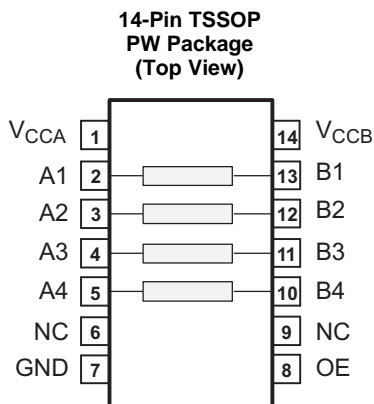

NC - No internal connection

Pin Functions

PIN		I/O	DESCRIPTION
NAME	NUMBER		
A1	2	I/O	Input-output 1 for the A port. This pin is referenced to V_{CCA} .
A2	3	I/O	Input-output 2 for the A port. This pin is referenced to V_{CCA} .
A3	4	I/O	Input-output 3 for the A port. This pin is referenced to V_{CCA} .
A4	5	I/O	Input-output 4 for the A port. This pin is referenced to V_{CCA} .
B1	13	I/O	Input-output 1 for the B port. This pin is referenced to V_{CCB} .
B2	12	I/O	Input-output 2 for the B port. This pin is referenced to V_{CCB} .
B3	11	I/O	Input-output 3 for the B port. This pin is referenced to V_{CCB} .
B4	10	I/O	Input-output 4 for the B port. This pin is referenced to V_{CCB} .
GND	7	—	Ground
NC	6	—	No connection
	9		
OE	8	O	Tri-state output-mode enable. Pull the OE pin low to place all outputs in tri-state mode. This pin is referenced to V_{CCA} .
V_{CCA}	1	I	A-port supply voltage. $1.65\text{ V} \leq V_{CCA} \leq 3.6\text{ V}$ and $V_{CCA} \leq V_{CCB}$.
V_{CCB}	14	I	B-port supply voltage. $2.3\text{ V} \leq V_{CCB} \leq 5.5\text{ V}$.

6 Specifications

6.1 Absolute Maximum Ratings⁽¹⁾

over operating free-air temperature range (unless otherwise noted)

			MIN	MAX	UNIT
Supply voltage	V_{CCA}		-0.5	4.6	V
	V_{CCB}		-0.5	6.5	
Input-output pin voltage, V_{IO} ⁽²⁾	A1, A2, A3, A4	A port	-0.5	4.6	V
	B1, B2, B3, B4	B port	-0.5	6.5	
Output voltage, V_O	Voltage range applied to any output in the high-impedance or power-off state ⁽²⁾	A port	-0.5	4.6	V
		B port	-0.5	6.5	
	Voltage range applied to any output in the high or low state ⁽²⁾⁽³⁾	A port	-0.5	$V_{CCA} + 0.5$	V
		B port	-0.5	$V_{CCB} + 0.5$	
Input clamp current, I_{IK}	$V_I < 0$		-50	mA	
Output clamp current, I_{OK}	$V_O < 0$		-50	mA	
Continuous output current, I_O			±50	mA	
Continuous current through each V_{CCA} , V_{CCB} , or GND			±100	mA	
Operating virtual junction temperature range, T_J			-40	125	°C

- (1) Stresses beyond those listed under *absolute maximum ratings* may cause permanent damage to the device. These are stress ratings only, and functional operation of the device at these or any other conditions beyond those indicated under *recommended operating conditions* is not implied. Exposure to absolute-maximum-rated conditions for extended periods may affect device reliability.
- (2) The input and output negative-voltage ratings may be exceeded if the input and output current ratings are observed.
- (3) The value of V_{CCA} and V_{CCB} are provided in the recommended operating conditions table.

6.2 Handling Ratings

			MIN	MAX	UNIT
T_{stg}	Storage temperature range		-65	150	°C
$V_{(ESD)}$	Electrostatic discharge	Human body model (HBM), per AEC Q100-002 ⁽¹⁾	-2.5	2.5	kV
		Charged device model (CDM), per AEC Q100-011, all pins	-1.5	1.5	

- (1) AEC Q100-002 indicates HBM stressing is done in accordance with the ANSI/ESDA/JEDEC JS-001 specification.

6.3 Recommended Operating Conditions

over operating free-air temperature range (unless otherwise noted)

			V_{CCA}	V_{CCB}	MIN	MAX	UNIT
V_{CCA}	Supply voltage ⁽¹⁾				1.65	3.6	V
V_{CCB}	Supply voltage ⁽¹⁾				2.3	5.5	V
$V_{IH(Ax)}$	High-level input voltage	A-port I/Os	1.65 to 1.95 V	2.3 to 5.5 V	$V_{CCA} - 0.2$	V_{CCA}	V
			2.3 to 3.6 V		$V_{CCA} - 0.4$	V_{CCA}	
$V_{IH(Bx)}$	High-level input voltage	B-port I/Os	1.65 to 3.6 V	2.3 to 5.5 V	$V_{CCB} - 0.4$	V_{CCB}	V
$V_{IH(OE)}$	High-level input voltage	OE input			$V_{CCA} \times 0.65$	5.5	
$V_{IL(Ax)}$	Low-level input voltage	A-port I/Os	1.65 to 3.6 V	2.3 to 5.5 V	0	0.15	V
$V_{IL(Bx)}$	Low-level input voltage	B-port I/Os			0	0.15	
$V_{IL(OE)}$	Low-level input voltage	OE input			0	$V_{CCA} \times 0.35$	
$\Delta t/\Delta v_{(Ax)}$	Input transition rise or fall rate	A-port I/Os, push-pull driving	1.65 to 3.6 V	2.3 to 5.5 V		10	ns/V
$\Delta t/\Delta v_{(Bx)}$	Input transition rise or fall rate	B-port I/Os, push-pull driving				10	
$\Delta t/\Delta v_{(OE)}$	Input transition rise or fall rate	OE input				10	
T_A	Operating free-air temperature				-40	125	°C

 (1) V_{CCA} must be less than or equal to V_{CCB} , and V_{CCA} must not exceed 3.6 V.

6.4 Thermal Information

over operating free-air temperature range (unless otherwise noted)

THERMAL METRIC ⁽¹⁾		PW (14-PINS)	UNIT
$R_{\theta JA}$	Junction-to-ambient thermal resistance	120.1	°C/W
$R_{\theta JC(top)}$	Junction-to-case (top) thermal resistance	49.1	
$R_{\theta JB}$	Junction-to-board thermal resistance	61.8	
Ψ_{JT}	Junction-to-top characterization parameter	6.2	
Ψ_{JB}	Junction-to-board characterization parameter	61.2	
$R_{\theta JC(bot)}$	Junction-to-case (bottom) thermal resistance	—	

 (1) For more information about traditional and new thermal metrics, see the *IC Package Thermal Metrics* application report, [SPRA953](#).

6.5 Electrical Characteristics⁽¹⁾

over recommended operating free-air temperature range (unless otherwise noted)

PARAMETER	TEST CONDITIONS	V _{CCA}	V _{CCB}	T _A = 25°C			T _A = 25°C to 125°C		UNIT		
				MIN	TYP	MAX	MIN	MAX			
V _{OH(Ax)}	High-level output voltage, A port	I _{OH} = -20 μA, V _{I(Bx)} ≥ V _{CCB} - 0.4 V	1.65 to 3.6 V	2.3 to 5.5 V			V _{CCA} × 0.75		V		
V _{OL(Ax)}	Low-level output voltage, A port	I _{OL} = 1 mA, V _{I(Bx)} ≤ 0.15 V	1.65 to 3.6 V	2.3 to 5.5 V			0.4		V		
V _{OH(Bx)}	High-level output voltage, B port	I _{OH} = -20 μA, V _{I(Ax)} ≥ V _{CCA} - 0.2 V	1.65 to 3.6 V	2.3 to 5.5 V			V _{CCB} × 0.75		V		
V _{OL(Bx)}	Low-level output voltage, B port	I _{OL} = 1 mA, V _{I(Ax)} ≤ 0.15 V	1.65 to 3.6 V	2.3 to 5.5 V			0.4		V		
I _{I(OE)}	Input current	OE	V _I = V _{CC1} or GND	1.65 to 3.6 V	2.3 to 5.5 V			±1	±2	μA	
I _{OZ}	Off-state output current	A or B port	OE = V _{IL}	1.65 to 3.6 V	2.3 to 5.5 V			±1	±3	μA	
I _{CCA}	Supply current, A port	V _I = V _O = Open, I _O = 0	1.65 to V _{CCB}	2.3 to 5.5 V					4	μA	
			3.6 V	0					2.2		
			0	5.5 V					-1		
I _{CCB}	Supply current, B port	V _I = V _O = Open, I _O = 0	1.65 to V _{CCB}	2.3 to 5.5 V					21	μA	
			3.6 V	0					-1		
			0	5.5 V					5		
I _{CCA} +I _{CCB}	Supply current, A port plus B port supply current	V _I = V _O = Open, I _O = 0	1.65 V to V _{CCB}	2.3 to 5.5 V					25	μA	
C _{I(OE)}	Input capacitance	OE		3.3 V	3.3 V			2.5		4	pF
C _{IO(Ax)}	Input-output capacitance	A port		3.3 V	3.3 V			5		6.5	pF
C _{IO(Bx)}		B port		3.3 V	3.3 V			12		16.5	

 (1) V_{CCA} must be less than or equal to V_{CCB}, and V_{CCA} must not exceed 3.6 V.

6.6 Timing Requirements—V_{CCA} = 1.8 V ± 0.15 V

over recommended operating free-air temperature range (unless otherwise noted)

		V _{CCB} = 2.5 V ± 0.2 V		V _{CCB} = 3.3 V ± 0.3 V		V _{CCB} = 5 V ± 0.5 V		UNIT
		MIN	MAX	MIN	MAX	MIN	MAX	
Data rate	Push-pull driving	18		21		23		Mbps
	Open-drain driving	2		2		2		
t _w	Pulse duration	55		47		43		ns
	See Figure 7	500		500		500		

6.7 Timing Requirements—V_{CCA} = 2.5 V ± 0.2 V

over recommended operating free-air temperature range (unless otherwise noted)

		V _{CCB} = 2.5 V ± 0.2 V		V _{CCB} = 3.3 V ± 0.3 V		V _{CCB} = 5 V ± 0.5 V		UNIT
		MIN	MAX	MIN	MAX	MIN	MAX	
Data rate	Push-pull driving	20		22		24		Mbps
	Open-drain driving	2		2		2		
t _w	Pulse duration	50		45		41		ns
	See Figure 7	500		500		500		

6.8 Timing Requirements— $V_{CCA} = 3.3\text{ V} \pm 0.3\text{ V}$

over recommended operating free-air temperature range (unless otherwise noted)

			$V_{CCB} = 3.3\text{ V} \pm 0.3\text{ V}$		$V_{CCB} = 5\text{ V} \pm 0.5\text{ V}$		UNIT
			MIN	MAX	MIN	MAX	
Data rate	Push-pull driving		22		24		Mbps
	Open-drain driving		2		2		
t_w	Pulse duration See Figure 7	Push-pull driving	45		41		ns
		Open-drain driving	500		500		

6.9 Switching Characteristics— $V_{CCA} = 1.8\text{ V} \pm 0.15\text{ V}$

over recommended operating free-air temperature range (unless otherwise noted)

PARAMETER			TEST CONDITIONS	$V_{CCB} = 2.5\text{ V} \pm 0.2\text{ V}$		$V_{CCB} = 3.3\text{ V} \pm 0.3\text{ V}$		$V_{CCB} = 5\text{ V} \pm 0.5\text{ V}$		UNIT
				MIN	MAX	MIN	MAX	MIN	MAX	
$t_{PHL(A-B)}$	Propagation delay time (high to low) See Figure 8	From A (input) to B (output)	Push-pull driving	6		5.8		5.8		ns
			Open-drain driving	8.8		9.6		10		
$t_{PHL(B-A)}$	Propagation delay time (high to low) See Figure 8	From B (input) to A (output)	Push-pull driving	4.4		4.5		4.7		ns
			Open-drain driving	5.3		4.4		4		
$t_{PLH(A-B)}$	Propagation delay time (low to high) See Figure 8	From A (input) to B (output)	Push-pull driving	7.7		6.8		7		ns
			Open-drain driving	50		26		33		
$t_{PLH(B-A)}$	Propagation delay time (low to high) See Figure 8	From B (input) to A (output)	Push-pull driving	5.3		4.5		0.5		ns
			Open-drain driving	36		16		20		
$t_{en(OE-A)}$ $t_{en(OE-B)}$	Enable time	From OE (input) to A or B (output)	200		200		200		ns	
$t_{dis(OE-A)}$ $t_{dis(OE-B)}$	Disable time	From OE (input) to A or B (output)	200		200		200		ns	
$t_{r(Ax)}$	Rise time, A port		Push-pull driving	9.5		9.3		15		ns
			Open-drain driving	38	199	30	150	22	109	
$t_{r(Bx)}$	Rise time, B port		Push-pull driving	10.8		9.1		7.6		ns
			Open-drain driving	34	186	23	112	10	58	
$t_{f(Ax)}$	Fall time, A port		Push-pull driving	5.9		6		13.3		ns
			Open-drain driving	6.9		6.4		6.1		
$t_{f(Bx)}$	Fall time, B port		Push-pull driving	7.6		7.5		8.8		ns
			Open-drain driving	13.8		16.2		16.2		
t_{sk}	Channel-to-channel skew		1		1		1		ns	
Maximum data rate			Push-pull driving	18		21		23		Mbps
			Open-drain driving	2		2		2		

6.10 Switching Characteristics— $V_{CCA} = 2.5 V \pm 0.2 V$

over recommended operating free-air temperature range (unless otherwise noted)

PARAMETER		TEST CONDITIONS	$V_{CCB} = 2.5 V \pm 0.2 V$		$V_{CCB} = 3.3 V \pm 0.3 V$		$V_{CCB} = 5 V \pm 0.5 V$		UNIT
			MIN	MAX	MIN	MAX	MIN	MAX	
$t_{PHL(A-B)}$	Propagation delay time (high to low) See Figure 8	From A (input) to B (output)	Push-pull driving		3.2		3.3		ns
			Open-drain driving		6.3		6		
$t_{PHL(B-A)}$	Propagation delay time (high to low) See Figure 8	From B (input) to A (output)	Push-pull driving		3		3.6		ns
			Open-drain driving		4.7		4.2		
$t_{PLH(A-B)}$	Propagation delay time (low to high) See Figure 8	From A (input) to B (output)	Push-pull driving		3.5		4.1		ns
			Open-drain driving		3.5		4.1		
$t_{PLH(B-A)}$	Propagation delay time (low to high) See Figure 8	From B (input) to A (output)	Push-pull driving		2.5		1.6		ns
			Open-drain driving		2.5		1.6		
$t_{en(OE-A)}$ $t_{en(OE-B)}$	Enable time	From OE (input) to A or B (output)	200		200		200		ns
$t_{dis(OE-A)}$ $t_{dis(OE-B)}$	Disable time	From OE (input) to A or B (output)	200		200		200		ns
$t_{r(Ax)}$	Rise time, A port	Push-pull driving	7.4		6.6		5.6		ns
		Open-drain driving	34	180	28	150	24	105	
$t_{r(Bx)}$	Rise time, B port	Push-pull driving	8.3		7.2		6.1		ns
		Open-drain driving	35	170	24	120	12	64	
$t_{f(Ax)}$	Fall time, A port	Push-pull driving	5.7		5.5		5.3		ns
		Open-drain driving	6.9		6.2		5.8		
$t_{f(Bx)}$	Fall time, B port	Push-pull driving	7.8		6.7		6.6		ns
		Open-drain driving	8.8		9.4		10.4		
t_{sk}	Channel-to-channel skew		1		1		1		ns
Maximum data rate		Push-pull driving	20		22		24		Mbps
		Open-drain driving	2		2		2		

6.11 Switching Characteristics— $V_{CCA} = 3.3\text{ V} \pm 0.3\text{ V}$

over recommended operating free-air temperature range (unless otherwise noted)

PARAMETER		TEST CONDITIONS	$V_{CCB} = 3.3\text{ V} \pm 0.3\text{ V}$		$V_{CCB} = 5\text{ V} \pm 0.5\text{ V}$		UNIT
			MIN	MAX	MIN	MAX	
$t_{PHL(A-B)}$	Propagation delay time (high to low) See Figure 8	From A (input) to B (output)	Push-pull driving		2.4	3.1	ns
			Open-drain driving		4.2	4.6	
$t_{PHL(B-A)}$	Propagation delay time (high to low) See Figure 8	From B (input) to A (output)	Push-pull driving		2.5	3.3	
			Open-drain driving		124	97	
$t_{PLH(A-B)}$	Propagation delay time (low to high) See Figure 8	From A (input) to B (output)	Push-pull driving		4.2	4.4	ns
			Open-drain driving		4.2	4.4	
$t_{PLH(B-A)}$	Propagation delay time (low to high) See Figure 8	From B (input) to A (output)	Push-pull driving		2.5	2.6	
			Open-drain driving		2.5	3.3	
$t_{en(OE-A)}$ $t_{en(OE-B)}$	Enable time	From OE (input) to A or B (output)			200	200	ns
$t_{dis(OE-A)}$ $t_{dis(OE-B)}$	Disable time	From OE (input) to A or B (output)			200	200	ns
$t_{r(Ax)}$	Rise time, A port		Push-pull driving		5.6	5	ns
			Open-drain driving		25	140	
$t_{r(Bx)}$	Rise time, B port		Push-pull driving		6.4	7.4	ns
			Open-drain driving		26	130	
$t_{f(Ax)}$	Fall time, A port		Push-pull driving		5.4	5	ns
			Open-drain driving		6.1	5.7	
$t_{f(Bx)}$	Fall time, B port		Push-pull driving		7.4	7.6	ns
			Open-drain driving		7.6	8.3	
t_{sk}	Channel-to-channel skew				1	1	ns
	Maximum data rate		Push-pull driving		22	24	Mbps
			Open-drain driving		2	2	

6.12 Typical Characteristics

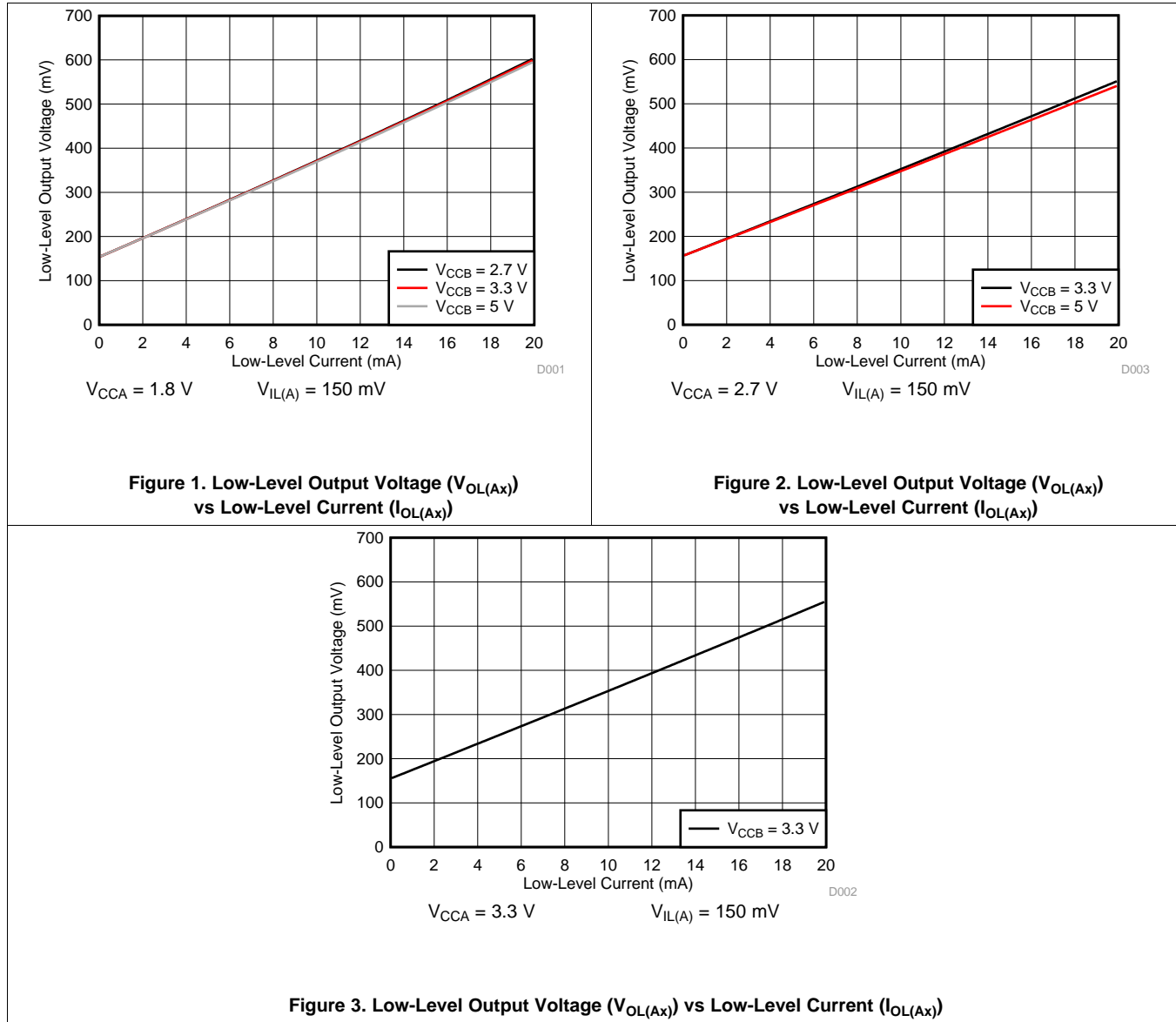

Figure 1. Low-Level Output Voltage ($V_{OL(Ax)}$) vs Low-Level Current ($I_{OL(Ax)}$)

Figure 2. Low-Level Output Voltage ($V_{OL(Ax)}$) vs Low-Level Current ($I_{OL(Ax)}$)

Figure 3. Low-Level Output Voltage ($V_{OL(Ax)}$) vs Low-Level Current ($I_{OL(Ax)}$)

7 Parameter Measurement Information

7.1 Load Circuits

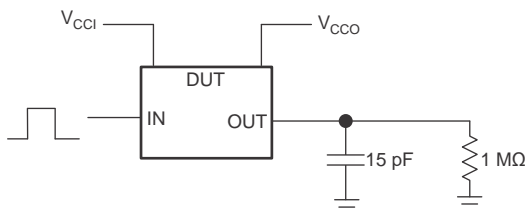

Figure 4. Data Rate, Pulse Duration, Propagation Delay, Output Rise-Time and Fall-Time Measurement Using a Push-Pull Driver

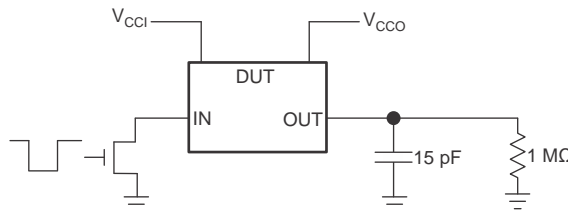
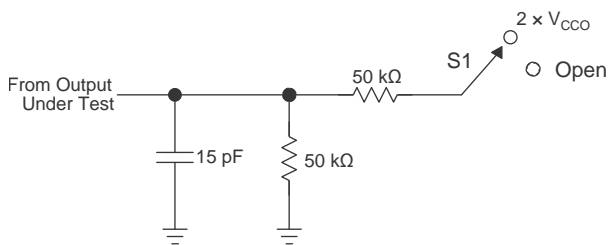

Figure 5. Data Rate, Pulse Duration, Propagation Delay, Output Rise-Time and Fall-Time Measurement Using an Open-Drain Driver



TEST	S1
t_{PZL} / t_{PLZ} (t_{dis})	$2 \times V_{CCO}$
t_{PHZ} / t_{PZH} (t_{en})	Open

Figure 6. Load Circuit for Enable-Time and Disable-Time Measurement

1. t_{PLZ} and t_{PHZ} are the same as t_{dis} .
2. t_{PZL} and t_{PZH} are the same as t_{en} .
3. V_{CCI} is the V_{CC} associated with the input port.
4. V_{CCO} is the V_{CC} associated with the output port.

7.2 Voltage Waveforms

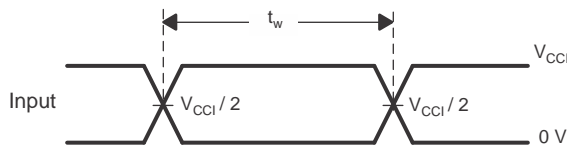

Figure 7. Pulse Duration

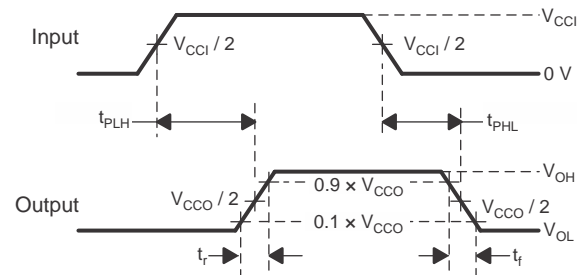

Figure 8. Propagation Delay Times

1. C_L includes probe and jig capacitance.
2. Waveform 1 in Figure 9 is for an output with internal such that the output is high, except when OE is high (see Figure 6). Waveform 2 in Figure 9 is for an output with conditions such that the output is low, except when OE is high.
3. All input pulses are supplied by generators having the following characteristics: $PRR \leq 10$ MHz, $Z_O = 50 \Omega$, $dv/dt \geq 1$ V/ns.
4. The outputs are measured one at a time, with one transition per measurement.
5. t_{PLZ} and t_{PHZ} are the same as t_{dis} .
6. t_{PZL} and t_{PZH} are the same as t_{en} .
7. t_{PLH} and t_{PHL} are the same as t_{pd} .
8. V_{CCI} is the V_{CC} associated with the input port.
9. V_{CCO} is the V_{CC} associated with the output port.

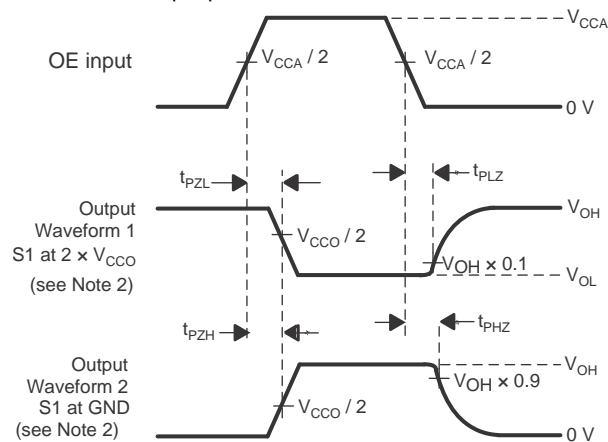

Figure 9. Enable and Disable Times

8 Detailed Description

8.1 Overview

The TXS0104E-Q1 device is a directionless voltage-level translator specifically designed for translating logic voltage levels. The A port is able to accept I/O voltages ranging from 1.65 V to 3.6 V, while the B port can accept I/O voltages from 2.3 V to 5.5 V. The device is a pass gate architecture with edge rate accelerators (one shots) to improve the overall data rate. 10-kΩ pullup resistors, commonly used in open drain applications, have been conveniently integrated so that an external resistor is not needed. While this device is designed for open drain applications, the device can also translate push-pull CMOS logic outputs.

8.2 Functional Block Diagram

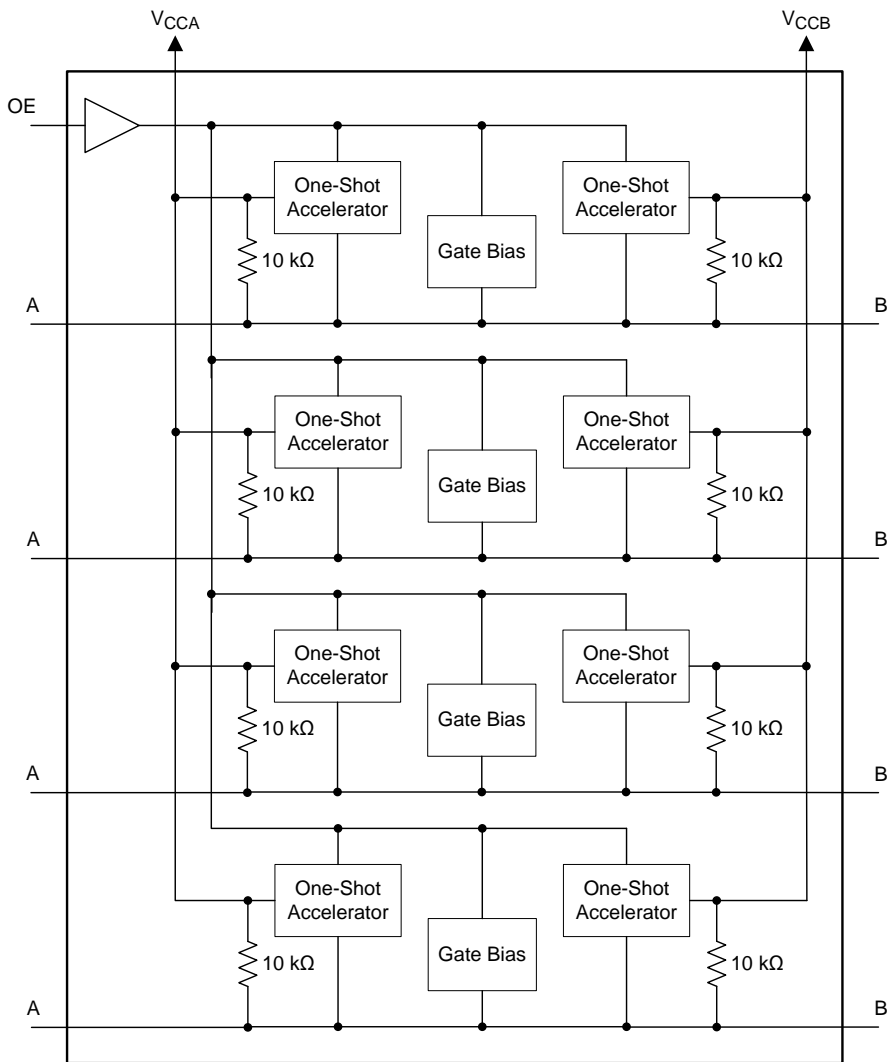

8.3 Feature Description

8.3.1 Architecture

The TXS0104E-Q1 architecture (see [Figure 10](#)) does not require a direction-control signal in order to control the direction of data flow from A to B or from B to A.

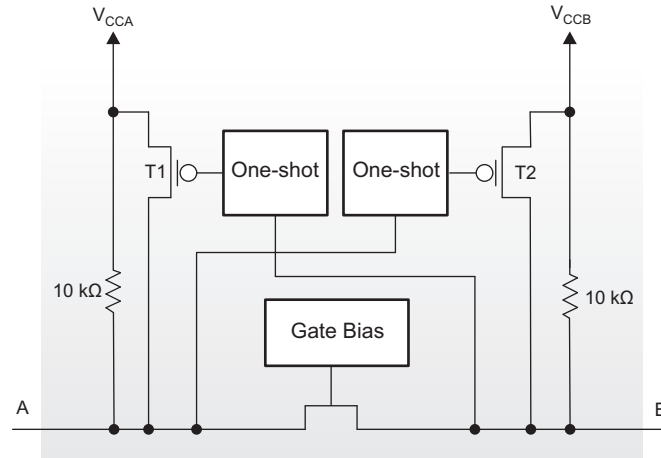

Figure 10. Architecture of a TXS01xx Cell

Each A-port I/O has an internal 10-k Ω pullup resistor to V_{CCA} , and each B-port I/O has an internal 10-k Ω pullup resistor to V_{CCB} . The output one-shots detect rising edges on the A or B ports. During a rising edge, the one-shot turns on the PMOS transistors (T1, T2) for a short duration which speeds up the low-to-high transition.

8.3.2 Input Driver Requirements

The fall time (t_{fA} , t_{fB}) of a signal depends on the output impedance of the external device driving the data I/Os of the TXS0104E-Q1 device. Similarly, the t_{PHL} and maximum data rates also depend on the output impedance of the external driver. The values for t_{fA} , t_{fB} , t_{PHL} , and maximum data rates in the data sheet assume that the output impedance of the external driver is less than 50 Ω .

8.3.3 Power Up

During operation, ensure that $V_{CCA} \leq V_{CCB}$ at all times. During power-up sequencing, $V_{CCA} \geq V_{CCB}$ does not damage the device, so any power supply can be ramped up first.

8.3.4 Enable and Disable

The TXS0104E-Q1 device has an OE input that disables the device by setting OE low, which places all I/Os in the high-impedance state. The disable time (t_{dis}) indicates the delay between the time when the OE pin goes low and when the outputs actually enter the high-impedance state. The enable time (t_{en}) indicates the amount of time the user must allow for the one-shot circuitry to become operational after the OE pin is taken high.

8.3.5 Pullup and Pulldown Resistors on I/O Lines

Each A-port I/O has an internal 10-k Ω pullup resistor to V_{CCA} , and each B-port I/O has an internal 10-k Ω pullup resistor to V_{CCB} . If a smaller value of pullup resistor is required, an external resistor must be added from the I/O to V_{CCA} or V_{CCB} (in parallel with the internal 10-k Ω resistors).

8.4 Device Functional Modes

The TXS0104E-Q1 device has two functional modes, enabled and disabled. To disable the device set the OE input low, which places all I/Os in a high impedance state. Setting the OE input high will enable the device.

9 Application and Implementation

9.1 Application Information

The TXS0104E-Q1 device can be used in level-translation applications for interfacing devices or systems operating at different interface voltages with one another. The TXS0104E-Q1 device is ideal for use in applications where an open-drain driver is connected to the data I/Os. The TXS0104E-Q1 device can also be used in applications where a push-pull driver is connected to the data I/Os, but the TXB0104-Q1 device might be a better option for such push-pull applications.

9.2 Typical Application

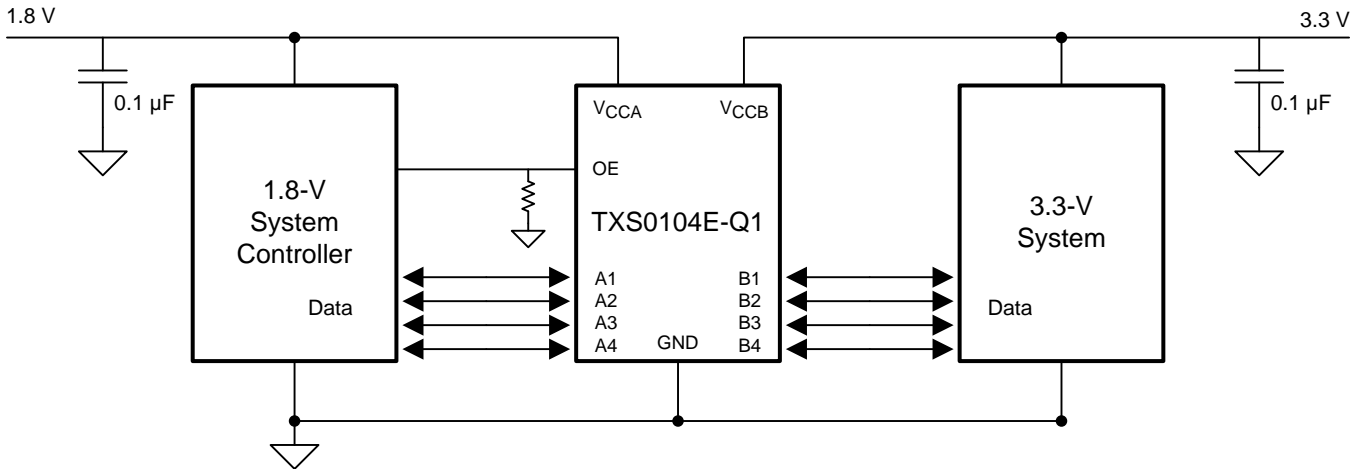

Figure 11. Application Schematic

9.2.1 Design Requirements

For this design example, use the parameters listed in [Table 1](#).

Table 1. Design Parameters

DESIGN PARAMETER	EXAMPLE VALUE
Input voltage range	1.65 to 3.6 V
Output voltage range	2.3 to 5.5 V

9.2.2 Detailed Design Procedure

To begin the design process, determine the following:

- Input voltage range
 - Use the supply voltage of the device that is driving the TXS0104E-Q1 device to determine the input voltage range. For a valid logic high the value must exceed the V_{IH} of the input port. For a valid logic low the value must be less than the V_{IL} of the input port.
- Output voltage range
 - Use the supply voltage of the device that the TXS0104E-Q1 device is driving to determine the output voltage range.
 - The TXS0104E-Q1 device has 10-k Ω internal pullup resistors. External pullup resistors can be added to reduce the total RC of a signal trace if necessary.

- An external pull down resistor decreases the output V_{OH} and V_{OL} . Use Equation 1 to calculate the V_{OH} as a result of an external pull down resistor.

$$V_{OH} = V_{CCx} \times R_{PD} / (R_{PD} + 10 \text{ k}\Omega)$$

where

- V_{CCx} is the supply voltage on either V_{CCA} or V_{CCB}
- R_{PD} is the value of the external pull down resistor

(1)

9.2.3 Application Curve

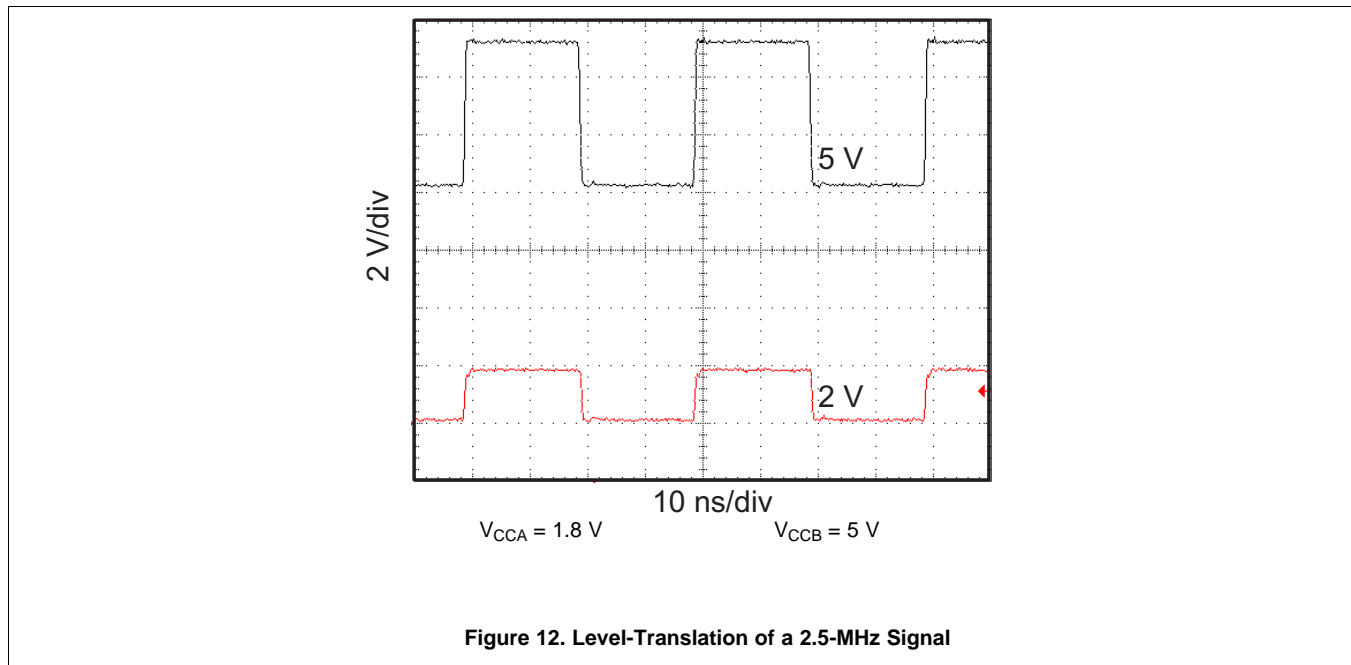

10 Power Supply Recommendations

The TXS0104E-Q1 device uses two separate configurable power-supply rails, V_{CCA} and V_{CCB} . V_{CCB} accepts any supply voltage from 2.3 V to 5.5 V and V_{CCA} accepts any supply voltage from 1.65 V to 3.6 V as long as V_S is less than or equal to V_{CCB} . The A port and B port are designed to track V_{CCA} and V_{CCB} respectively allowing for low-voltage bidirectional translation between any of the 1.8-V, 2.5-V, 3.3-V, and 5-V voltage nodes.

The TXS0104E-Q1 device does not require power sequencing between V_{CCA} and V_{CCB} during power-up so the power-supply rails can be ramped in any order. A V_{CCA} value greater than or equal to V_{CCB} ($V_{CCA} \geq V_{CCB}$) does not damage the device, but during operation, V_{CCA} must be less than or equal to V_{CCB} ($V_{CCA} \leq V_{CCB}$) at all times.

The output-enable (OE) input circuit is designed so that it is supplied by V_{CCA} and when the (OE) input is low, all outputs are placed in the high-impedance state. To ensure the high-impedance state of the outputs during power up or power down, the OE input pin must be tied to GND through a pulldown resistor and must not be enabled until V_{CCA} and V_{CCB} are fully ramped and stable. The minimum value of the pulldown resistor to ground is determined by the current-sourcing capability of the driver.

11 Layout

11.1 Layout Guidelines

To ensure reliability of the device, following common printed-circuit board layout guidelines is recommended.

- Bypass capacitors should be used on power supplies.
- Short trace lengths should be used to avoid excessive loading.
- PCB signal trace-lengths must be kept short enough so that the round-trip delay of any reflection is less than the one shot duration, approximately 30 ns, ensuring that any reflection encounters low impedance at the source driver.
- Placing pads on the signal paths for loading capacitors or pullup resistors to help adjust rise and fall times of signals depending on the system requirements

11.2 Layout Example

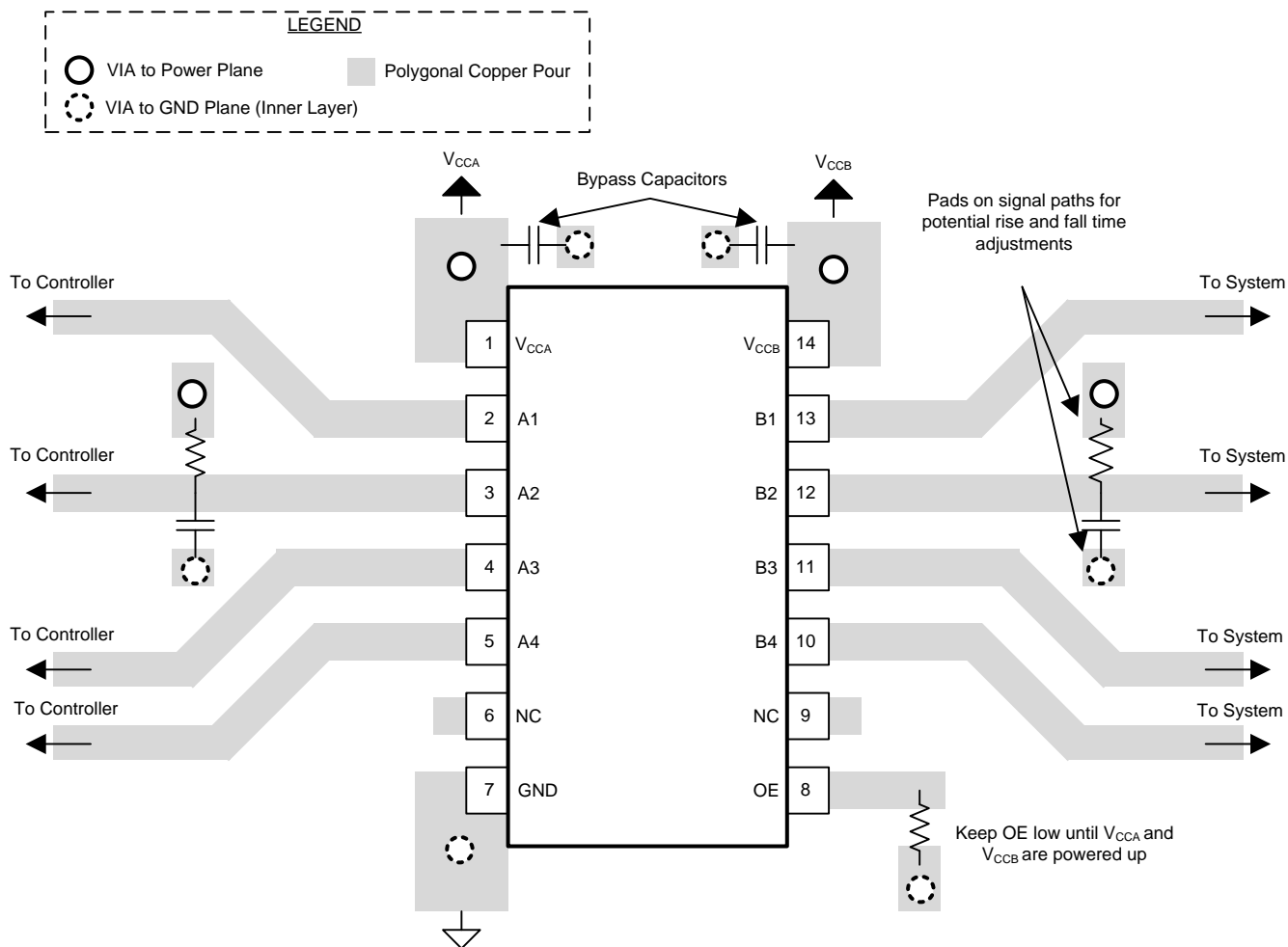

12 Device and Documentation Support

12.1 Trademarks

All trademarks are the property of their respective owners.

12.2 Electrostatic Discharge Caution



This integrated circuit can be damaged by ESD. Texas Instruments recommends that all integrated circuits be handled with appropriate precautions. Failure to observe proper handling and installation procedures can cause damage.

ESD damage can range from subtle performance degradation to complete device failure. Precision integrated circuits may be more susceptible to damage because very small parametric changes could cause the device not to meet its published specifications.

12.3 Glossary

[SLYZ022](#) — *TI Glossary*.

This glossary lists and explains terms, acronyms and definitions.

13 Mechanical, Packaging, and Orderable Information

The following pages include mechanical packaging and orderable information. This information is the most current data available for the designated devices. This data is subject to change without notice and revision of this document. For browser-based versions of this data sheet, refer to the left-hand navigation.

PACKAGING INFORMATION

Orderable Device	Status (1)	Package Type	Package Drawing	Pins	Package Qty	Eco Plan (2)	Lead/Ball Finish (6)	MSL Peak Temp (3)	Op Temp (°C)	Device Marking (4/5)	Samples
TXS0104EQPWRQ1	ACTIVE	TSSOP	PW	14	2000	Green (RoHS & no Sb/Br)	CU NIPDAU	Level-3-260C-168 HR	-40 to 125	04EQ1	Samples

(1) The marketing status values are defined as follows:

ACTIVE: Product device recommended for new designs.

LIFEBUY: TI has announced that the device will be discontinued, and a lifetime-buy period is in effect.

NRND: Not recommended for new designs. Device is in production to support existing customers, but TI does not recommend using this part in a new design.

PREVIEW: Device has been announced but is not in production. Samples may or may not be available.

OBSELETE: TI has discontinued the production of the device.

(2) Eco Plan - The planned eco-friendly classification: Pb-Free (RoHS), Pb-Free (RoHS Exempt), or Green (RoHS & no Sb/Br) - please check <http://www.ti.com/productcontent> for the latest availability information and additional product content details.

TBD: The Pb-Free/Green conversion plan has not been defined.

Pb-Free (RoHS): TI's terms "Lead-Free" or "Pb-Free" mean semiconductor products that are compatible with the current RoHS requirements for all 6 substances, including the requirement that lead not exceed 0.1% by weight in homogeneous materials. Where designed to be soldered at high temperatures, TI Pb-Free products are suitable for use in specified lead-free processes.

Pb-Free (RoHS Exempt): This component has a RoHS exemption for either 1) lead-based flip-chip solder bumps used between the die and package, or 2) lead-based die adhesive used between the die and leadframe. The component is otherwise considered Pb-Free (RoHS compatible) as defined above.

Green (RoHS & no Sb/Br): TI defines "Green" to mean Pb-Free (RoHS compatible), and free of Bromine (Br) and Antimony (Sb) based flame retardants (Br or Sb do not exceed 0.1% by weight in homogeneous material)

(3) MSL, Peak Temp. - The Moisture Sensitivity Level rating according to the JEDEC industry standard classifications, and peak solder temperature.

(4) There may be additional marking, which relates to the logo, the lot trace code information, or the environmental category on the device.

(5) Multiple Device Markings will be inside parentheses. Only one Device Marking contained in parentheses and separated by a "~" will appear on a device. If a line is indented then it is a continuation of the previous line and the two combined represent the entire Device Marking for that device.

(6) Lead/Ball Finish - Orderable Devices may have multiple material finish options. Finish options are separated by a vertical ruled line. Lead/Ball Finish values may wrap to two lines if the finish value exceeds the maximum column width.

Important Information and Disclaimer: The information provided on this page represents TI's knowledge and belief as of the date that it is provided. TI bases its knowledge and belief on information provided by third parties, and makes no representation or warranty as to the accuracy of such information. Efforts are underway to better integrate information from third parties. TI has taken and continues to take reasonable steps to provide representative and accurate information but may not have conducted destructive testing or chemical analysis on incoming materials and chemicals. TI and TI suppliers consider certain information to be proprietary, and thus CAS numbers and other limited information may not be available for release.

In no event shall TI's liability arising out of such information exceed the total purchase price of the TI part(s) at issue in this document sold by TI to Customer on an annual basis.

OTHER QUALIFIED VERSIONS OF TXS0104E-Q1 :

- Catalog: [TXS0104E](#)

NOTE: Qualified Version Definitions:

- Catalog - TI's standard catalog product

TAPE AND REEL INFORMATION



QUADRANT ASSIGNMENTS FOR PIN 1 ORIENTATION IN TAPE



*All dimensions are nominal

Device	Package Type	Package Drawing	Pins	SPQ	Reel Diameter (mm)	Reel Width W1 (mm)	A0 (mm)	B0 (mm)	K0 (mm)	P1 (mm)	W (mm)	Pin1 Quadrant
TXS0104EQPWRQ1	TSSOP	PW	14	2000	330.0	12.4	6.9	5.6	1.6	8.0	12.0	Q1

TAPE AND REEL BOX DIMENSIONS

*All dimensions are nominal

Device	Package Type	Package Drawing	Pins	SPQ	Length (mm)	Width (mm)	Height (mm)
TXS0104EQPWRQ1	TSSOP	PW	14	2000	367.0	367.0	35.0

PW (R-PDSO-G14)

PLASTIC SMALL OUTLINE

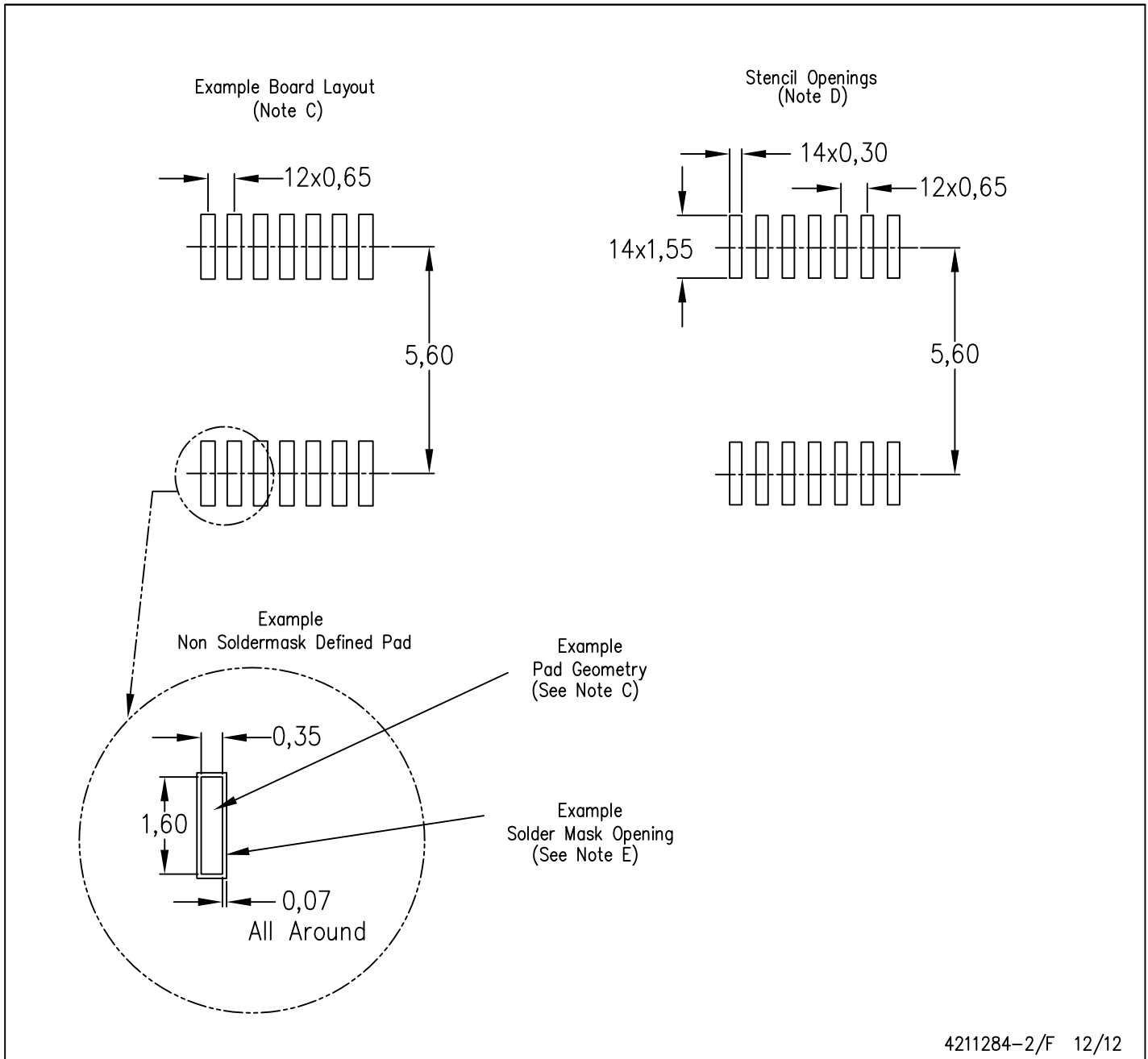

- NOTES:
- All linear dimensions are in millimeters.
 - This drawing is subject to change without notice.
 - Publication IPC-7351 is recommended for alternate designs.
 - Laser cutting apertures with trapezoidal walls and also rounding corners will offer better paste release. Customers should contact their board assembly site for stencil design recommendations. Refer to IPC-7525 for other stencil recommendations.
 - Customers should contact their board fabrication site for solder mask tolerances between and around signal pads.

IMPORTANT NOTICE

Texas Instruments Incorporated and its subsidiaries (TI) reserve the right to make corrections, enhancements, improvements and other changes to its semiconductor products and services per JESD46, latest issue, and to discontinue any product or service per JESD48, latest issue. Buyers should obtain the latest relevant information before placing orders and should verify that such information is current and complete. All semiconductor products (also referred to herein as "components") are sold subject to TI's terms and conditions of sale supplied at the time of order acknowledgment.

TI warrants performance of its components to the specifications applicable at the time of sale, in accordance with the warranty in TI's terms and conditions of sale of semiconductor products. Testing and other quality control techniques are used to the extent TI deems necessary to support this warranty. Except where mandated by applicable law, testing of all parameters of each component is not necessarily performed.

TI assumes no liability for applications assistance or the design of Buyers' products. Buyers are responsible for their products and applications using TI components. To minimize the risks associated with Buyers' products and applications, Buyers should provide adequate design and operating safeguards.

TI does not warrant or represent that any license, either express or implied, is granted under any patent right, copyright, mask work right, or other intellectual property right relating to any combination, machine, or process in which TI components or services are used. Information published by TI regarding third-party products or services does not constitute a license to use such products or services or a warranty or endorsement thereof. Use of such information may require a license from a third party under the patents or other intellectual property of the third party, or a license from TI under the patents or other intellectual property of TI.

Reproduction of significant portions of TI information in TI data books or data sheets is permissible only if reproduction is without alteration and is accompanied by all associated warranties, conditions, limitations, and notices. TI is not responsible or liable for such altered documentation. Information of third parties may be subject to additional restrictions.

Resale of TI components or services with statements different from or beyond the parameters stated by TI for that component or service voids all express and any implied warranties for the associated TI component or service and is an unfair and deceptive business practice. TI is not responsible or liable for any such statements.

Buyer acknowledges and agrees that it is solely responsible for compliance with all legal, regulatory and safety-related requirements concerning its products, and any use of TI components in its applications, notwithstanding any applications-related information or support that may be provided by TI. Buyer represents and agrees that it has all the necessary expertise to create and implement safeguards which anticipate dangerous consequences of failures, monitor failures and their consequences, lessen the likelihood of failures that might cause harm and take appropriate remedial actions. Buyer will fully indemnify TI and its representatives against any damages arising out of the use of any TI components in safety-critical applications.

In some cases, TI components may be promoted specifically to facilitate safety-related applications. With such components, TI's goal is to help enable customers to design and create their own end-product solutions that meet applicable functional safety standards and requirements. Nonetheless, such components are subject to these terms.

No TI components are authorized for use in FDA Class III (or similar life-critical medical equipment) unless authorized officers of the parties have executed a special agreement specifically governing such use.

Only those TI components which TI has specifically designated as military grade or "enhanced plastic" are designed and intended for use in military/aerospace applications or environments. Buyer acknowledges and agrees that any military or aerospace use of TI components which have **not** been so designated is solely at the Buyer's risk, and that Buyer is solely responsible for compliance with all legal and regulatory requirements in connection with such use.

TI has specifically designated certain components as meeting ISO/TS16949 requirements, mainly for automotive use. In any case of use of non-designated products, TI will not be responsible for any failure to meet ISO/TS16949.

Products

Audio	www.ti.com/audio
Amplifiers	amplifier.ti.com
Data Converters	dataconverter.ti.com
DLP® Products	www.dlp.com
DSP	dsp.ti.com
Clocks and Timers	www.ti.com/clocks
Interface	interface.ti.com
Logic	logic.ti.com
Power Mgmt	power.ti.com
Microcontrollers	microcontroller.ti.com
RFID	www.ti-rfid.com
OMAP Applications Processors	www.ti.com/omap
Wireless Connectivity	www.ti.com/wirelessconnectivity

Applications

Automotive and Transportation	www.ti.com/automotive
Communications and Telecom	www.ti.com/communications
Computers and Peripherals	www.ti.com/computers
Consumer Electronics	www.ti.com/consumer-apps
Energy and Lighting	www.ti.com/energy
Industrial	www.ti.com/industrial
Medical	www.ti.com/medical
Security	www.ti.com/security
Space, Avionics and Defense	www.ti.com/space-avionics-defense
Video and Imaging	www.ti.com/video

TI E2E Community

e2e.ti.com