

IEEE 1394b THREE-PORT CABLE TRANSCEIVER/ARBITER

FEATURES

- Fully Supports Provisions of IEEE 1394b-2002 at S100, S100B, S200, S200B, S400, and S400B Signaling Rates (B Signifies IEEE 1394b Signaling)
- Fully Supports Provisions of IEEE 1394a-2000 and 1394-1995 Standards for High-Performance Serial Bus
- Fully Interoperable With Firewire™, DTVLink, SB1394, DishWire, and i.LINK™ Implementation of IEEE Std 1394
- Provides Three Fully Backward-Compatible, (1394a-2000 Fully Compliant) Bilingual 1394b Cable Ports at 400 Megabits per Second (Mbps)
- Same Three Fully Backward-Compatible Ports Are 1394a-2000 Fully Compliant Cable Ports at 100/200/400 Mbps
- Full 1394a-2000 Support Includes:
 - Connection Debounce
 - Arbitrated Short Reset
 - Multispeed Concatenation
 - Arbitration Acceleration
 - Fly-By Concatenation
 - Port Disable/Suspend/Resume
 - Extended Resume Signaling for Compatibility With Legacy DV Devices
- Power-Down Features to Conserve Energy in Battery-Powered Applications
- Low-Power Automotive Sleep Mode Support
- Fully Compliant With Open Host Controller Interface (OHCI) Requirements
- Cable Power Presence Monitoring
- Cable Ports Monitor Line Conditions for Active Connection to Remote Node
- Register Bits Give Software Control of Contender Bit, Power Class Bits, Link Active Control Bit, and 1394a-2000 Features
- Interface to Link-Layer Controller Supports Low-Cost TI Bus-Holder Isolation
- Data Interface to Link-Layer Controller Terminal-Selectable From 1394a-2000 Mode (2/4/8 Parallel Bits at 49.152 MHz) or 1394b Mode (Eight Parallel Bits at 98.304 MHz)
- Interoperable With Link-Layer Controllers Using 3.3-V Supplies
- Interoperable With Other 1394 Physical Layers (PHYs) Using 1.8-V, 3.3-V, and 5-V Supplies
- Low-Cost 49.152-MHz Crystal Provides Transmit and Receive Data at 100/200/400 Mbps and Link-Layer Controller Clock at 49.152 MHz and 98.304 MHz
- Separate Bias (TPBIAS) for Each Port
- Low-Cost, High-Performance 80-Terminal TQFP (PFP) Thermally Enhanced Package
- Software Device Reset (SWR)
- Fail-Safe Circuitry Senses Sudden Loss of Power to the Device and Disables the Ports to Ensure That the TSB41BA3D Does Not Load the TPBIAS of Any Connected Device and Blocks Any Leakage From the Port Back to Power Plane
- 1394a-2000-Compliant, Common-Mode Noise Filter on the Incoming Bias Detect Circuit to Filter Out Crosstalk Noise
- Cable/Transceiver Hardware Speed and Port Mode Are Selectable by Terminal States
- Supports Connection to CAT5 Cable Transceiver by Allowing Ports to be Forced to Beta-Only, 400-Mbps-Only, 200-Mbps-Only or 100-Mbps-Only
- Supports Connection to S200 Plastic Optical Fiber Transceivers by Allowing Ports to be Forced to 1394b Beta-Only, S200-Mbps-Only, and S100-Mbps-Only
- Optical Signal Detect Input for All Ports in Beta Mode Enables Connection to Optical Transceivers
- Supports Use of 1394a Connectors by Allowing Ports 1 and 2 to Be Forced to 1394a-Only Mode



Please be aware that an important notice concerning availability, standard warranty, and use in critical applications of Texas Instruments semiconductor products and disclaimers thereto appears at the end of this data sheet.

PowerPAD is a trademark of Texas Instruments.

Firewire is a trademark of Apple Computer, Inc.

i.LINK is a trademark of Sony Kabushiki Kaisha TA Sony Corporation.

All other trademarks are the property of their respective owners.

DESCRIPTION/ORDERING INFORMATION

The TSB41BA3D provides the digital and analog transceiver functions needed to implement a three-port node in a cable-based IEEE 1394 network. Each cable port incorporates two differential line transceivers. The transceivers include circuitry to monitor the line conditions as needed for determining connection status, for initialization and arbitration, and for packet reception and transmission. The TSB41BA3D interfaces with a link-layer controller (LLC), such as the TSB82AA2, TSB12LV21, TSB12LV26, TSB12LV32, TSB42AA4, TSB42AB4, TSB12LV01B, or TSB12LV01C. It can also be connected via cable port to an integrated 1394 Link + PHY layer such as the TSB43AB2.

The TSB41BA3D is powered by a single 3.3-V supply. The core voltage supply is supplied by an internal voltage regulator to the PLLVDD-CORE and DVDD-CORE terminals. To protect the phase-locked loop (PLL) from noise, the PLLVDD-CORE terminals must be separately decoupled from the DVDD-CORE terminals. The PLLVDD-CORE terminals are decoupled with 1-μF and smaller decoupling capacitors and the DVDD-CORE terminals are separately decoupled with 1-μF and smaller decoupling capacitors. The separation between DVDD-CORE and PLLVDD-CORE must be implemented by separate power supply rails or planes.

The TSB41BA3D can be powered by dual supplies, a 3.3-V supply for I/O and a core voltage supply. The core voltage supply is supplied to the PLLVDD-CORE and DVDD-CORE terminals to the requirements in the *recommended operating conditions* section of this data sheet. The PLLVDD-CORE terminals must be separated from the DVDD-CORE terminals, the PLLVDD-CORE terminals are decoupled with 1-μF and smaller decoupling capacitors and the DVDD-CORE terminals separately decoupled with 1-μF and smaller decoupling capacitors. The separation between DVDD-CORE and PLLVDD-CORE can be implemented by separate power supply rails, or by a single power supply rail, where the DVDD-CORE and PLLVDD-CORE are separated by a filter network to keep noise from the PLLVDD-CORE supply.

The TSB41BA3D requires an external 49.152-MHz crystal to generate a reference clock. The external clock drives an internal PLL, which generates the required reference signal. This reference signal provides the clock signals that control transmission of the outbound encoded information. A 49.152-MHz clock signal is supplied by the PHY to the associated LLC for synchronization of the two devices and is used for resynchronization of the received data when operating the PHY-link interface in compliance with the IEEE 1394a-2000 standard. A 98.304-MHz clock signal is supplied by the PHY to the associated LLC for synchronization of the two devices when operating the PHY-link interface in compliance with the IEEE 1394b-2002 standard. The power-down (PD) function, when enabled by asserting the PD terminal high, stops operation of the PLL.

Data bits to be transmitted through the cable ports are received from the LLC on 2, 4, or 8 parallel paths (depending on the requested transmission speed and PHY-link interface mode of operation). They are latched internally, combined serially, encoded, and transmitted at 98.304, 122.78, 196.608, 245.76, 393.216, or 491.52 Mbps (referred to as S100, S100B, S200, S200B, S400, or S400B speed, respectively) as the outbound information stream.

The PHY-link interface can follow either the IEEE 1394a-2000 protocol or the IEEE 1394b-2002 protocol. When using a 1394a-2000 LLC such as the TSB12LV26, the BMODE terminal must be deasserted. The PHY-link interface then operates in accordance with the legacy 1394a-2000 standard. When using a 1394b LLC such as the TSB82AA2, the BMODE terminal must be asserted. The PHY-link interface then conforms to the 1394b-2002 standard.

The cable interface can follow either the IEEE 1394a-2000 protocol or the 1394b protocol on all ports. The mode of operation is determined by the interface capabilities of the ports being connected. When any of the three ports is connected to a 1394a-2000-compliant device, the cable interface on that port operates in the 1394a-2000 data-strobe mode at a compatible S100, S200, or S400 speed. When a bilingual port is connected to a 1394b-compliant node, the cable interface on that port operates per the 1394b-2002 standard at S100B, S200B, or S400B speed. The TSB41BA3D automatically determines the correct cable interface connection method for the bilingual ports.

ORDERING INFORMATION

T _A	PACKAGE ⁽¹⁾	ORDERABLE PART NUMBER	TOP-SIDE MARKING
0°C to 70°C	HTQFP – PFP	TSB41BA3DPFP	TSB41BA3D
–40°C to 85°C	HTQFP – PFP	TSB41BA3DIPFP	TSB41BA3DI

(1) Package drawings, standard packing quantities, thermal data, symbolization, and PCB design guidelines are available at www.ti.com/sc/package.

NOTE:

The BMODE terminal does not select the cable interface mode of operation. The BMODE terminal selects the PHY-link interface mode of operation and affects the arbitration modes on the cable. When the BMODE terminal is deasserted, the PHY-link interface is placed in 1394a-2000 mode and BOSS arbitration is disabled. When the BMODE terminal is asserted, the PHY-link interface is placed in 1394b-2002 mode and BOSS arbitration is enabled.

During packet reception, the serial data bits are split into 2-, 4-, or 8-bit parallel streams (depending on the indicated receive speed and the PHY-link interface mode of operation), resynchronized to the local system clock, and sent to the associated LLC. The received data is also transmitted (repeated) on the other connected and active cable ports.

Both the twisted pair A (TPA) and the twisted pair B (TPB) cable interfaces incorporate differential comparators to monitor the line states during initialization and arbitration when connected to a 1394a-2000-compliant device. The outputs of these comparators are used by the internal logic to determine the arbitration status. The TPA channel monitors the incoming cable common-mode voltage. The value of this common-mode voltage is used during 1394a-mode arbitration and sets the speed of the next packet transmission. In addition, the TPB channel monitors the incoming cable common-mode voltage on the TPB pair for the presence of the remotely supplied twisted pair bias (TPBIAS) voltage.

When connected to a 1394a-2000-compliant node, the TSB41BA3D provides a 1.86-V nominal bias voltage at the TPBIAS terminal for port termination. The PHY contains three independent TPBIAS circuits (one for each port). This bias voltage, when seen through a cable by a remote receiver, indicates the presence of an active connection. This bias voltage source must be stabilized by an external filter capacitor of 1 μ F.

The line drivers in the TSB41BA3D are designed to work with external 112- Ω termination resistor networks in order to match the 110- Ω cable impedance. One termination network is required at each end of a twisted-pair cable. Each network is composed of a pair of series-connected \sim 56- Ω resistors. The midpoint of the pair of resistors that is connected to the TPA terminals is connected to its corresponding TPBIAS voltage terminal. The midpoint of the pair of resistors that is directly connected to the TPB terminals is coupled to ground through a parallel RC network with recommended values of 5 k Ω and 270 pF. The values of the external line-termination resistors are designed to meet the standard specifications when connected in parallel with the internal receiver circuits. A precision external resistor connected between the R0 and R1 terminals sets the driver output current, along with other internal operating currents.

When the power supply of the TSB41BA3D is off while the twisted-pair cables are connected, the TSB41BA3D transmitter and receiver circuitry present a high-impedance signal to the cable that does not load the device at the other end of the cable.

When the TSB41BA3D is used without one or more of the ports brought out to a connector, the twisted-pair terminals of the unused ports must be terminated for reliable operation. For each unused port, the preferred method is for the port to be forced to the 1394a-only mode (data-strobe-only mode, DS), then the TPB+ and TPB– terminals can be tied together and then pulled to ground; or the TPB+ and TPB– terminals can be connected to the suggested normal termination network. The TPA+ and TPA– terminals of an unused port can be left unconnected. The TPBIAS#_SD# terminal can be left unconnected.

If the port is left in bilingual (Bi) mode, then the TPB+ and TPB– terminals can be left unconnected or the TPB+ and TPB– terminals can be connected to the suggested normal termination network. The TPA+ and TPA– terminals of an unused port can be left unconnected. The TPBIAS#_SD# terminal can be left unconnected.

If the port is left in a forced 1394b Beta-only (B1, B2, or B4) mode, then the TPB+ and TPB– terminals can be left unconnected or the TPB+ and TPB– terminals can be connected to the suggested normal termination network. The TPA+ and TPA– terminals of an unused port can be left unconnected. The TPBIAS#_SD# terminal must be pulled to ground through a 1.2-k Ω or smaller resistor.

To operate a port as a 1394b bilingual port, the speed/mode selections terminals (S5_LKON, S4, S3, S2_PC0, S1_PC1, and S0_PC2) need to be pulled to V_{CC} or ground through a 1-k Ω resistor. The port must be operated in the 1394b bilingual mode whenever a 1394b bilingual or a 1394b Beta-only connector is connected to the port. To operate the port as a 1394a-only port, the speed/mode selection terminals must be configured correctly to force 1394a-2000-only operation on that port. The only time the port must be forced to the data-strobe-only mode is if the port is connected to a 1394a connector (either 6-pin, which is recommended, or 4-pin). This mode is provided to ensure that 1394b signaling is never sent across a 1394a cable.

NOTE:

A bilingual port can only connect to a 1394b-only port that operates at S400b. It cannot establish a connection to a S200b or S100b port. A port that has been forced to S400b (B4) can connect to a 1394b-only port at S400b (B4) or S200b (B2) or S100b (B1). A port that has been forced to S200b can connect to a 1394b-only port at S200b or S100b. A port that has been forced to S100b can only connect to a 1394b-only port at S100b.

The TESTM, SE, and SM terminals are used to set up various manufacturing test conditions. For normal operation, the TESTM terminal must be connected to V_{DD} through a 1-k Ω resistor. The SE and SM terminals must be tied to ground through a 1-k Ω resistor.

Three package terminals are used as inputs to set the default value for three configuration status bits in the self-ID packet. They can be pulled high through a 1-k Ω resistor or hardwired low as a function of the equipment design. In some speed/mode selections the S2_PC0, S1_PC1, and S0_PC2 terminals indicate the default power-class status for the node (the need for power from the cable or the ability to supply power to the cable); see [Table 2](#). The contender bit in the PHY register set indicates that the node is a contender either for the isochronous resource manager (IRM) or for the bus manager (BM). On the TSB41BA3D, this bit can only be set by a write to the PHY register set. If a node is a contender for IRM or BM, then the node software must set this bit in the PHY register set.

The LPS (link power status) terminal works with the S5_LKON terminal to manage the power usage in the node. The LPS signal from the LLC is used with the LCtrl bit (see [Table 4](#) and [Table 5](#) in the APPLICATION INFORMATION section) to indicate the active/power status of the LLC. The LPS signal also resets, disables, and initializes the PHY-LLC interface (the state of the PHY-LCC interface is controlled solely by the LPS input regardless of the state of the LCtrl bit).

NOTE:

The TSB41BA3D does not have a cable-not-active (CNA) terminal. To achieve a similar function, the individual PHY ports can be set up to issue interrupts whenever the port changes state. If the LPS terminal is low, then this generates a link-on (LKON) output clock. See register bits PIE, PEI, and WDIE along with the individual interrupt bits.

The LPS input is considered inactive if it remains low for more than the LPS_RESET time (see the LPS terminal definition) and is considered active otherwise. When the TSB41BA3D detects that the LPS input is inactive, the PHY-LLC interface is placed into a low-power reset state in which the CTL and D outputs are held in the logic 0 state and the LREQ input is ignored; however, the PCLK output remains active. If the LPS input remains low for more than the LPS_DISABLE time (see the LPS terminal definition), then the PHY-LLC interface is put into a low-power disabled state in which the PCLK output is also held inactive. The TSB41BA3D continues the necessary repeater functions required for normal network operation regardless of the state of the PHY-LLC interface. When the interface is in the reset or disabled state and the LPS input is again observed active, the PHY initializes the interface and returns to normal operation. The PHY-LLC interface is also held in the disabled state during hardware reset. When the LPS terminal is returned to an active state after being sensed as having entered the LPS_DISABLE time, the TSB41BA3D issues a bus reset. This broadcasts the node self-ID packet, which contains the updated L bit state (the PHY LLC now being accessible).

The PHY uses the S5_LKON terminal to notify the LLC to power up and become active. When activated, the output S5_LKON signal is a square wave. The PHY activates the S5_LKON output when the LLC is inactive and a wake-up event occurs. The LLC is considered inactive when either the LPS input is inactive, as previously described, or the LCtrl bit is cleared to 0. A wake-up event occurs when a link-on PHY packet addressed to this node is received, or conditionally when a PHY interrupt occurs. The PHY deasserts the S5_LKON output when the LLC becomes active (both LPS sensed as active and the LCtrl bit set to 1). The PHY also deasserts the S5_LKON output when a bus reset occurs, unless a PHY interrupt condition exists which would otherwise cause S5_LKON to be active. If the PHY is power-cycled and the power class is 0 through 4, then the PHY asserts S5_LKON for approximately 167 s or until both the LPS is active and the LCtrl bit is 1.

TERMINAL ASSIGNMENTS

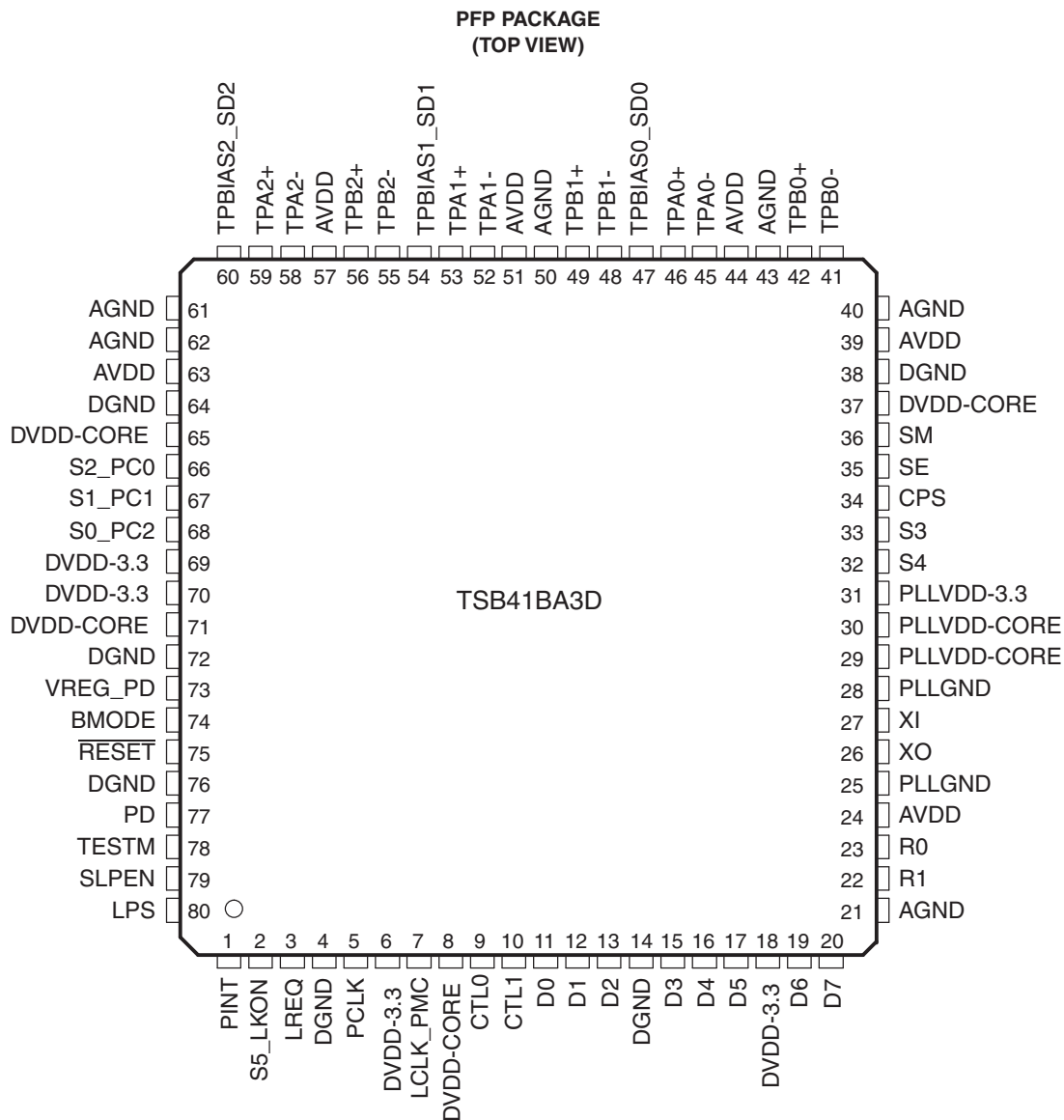

FUNCTIONAL BLOCK DIAGRAM

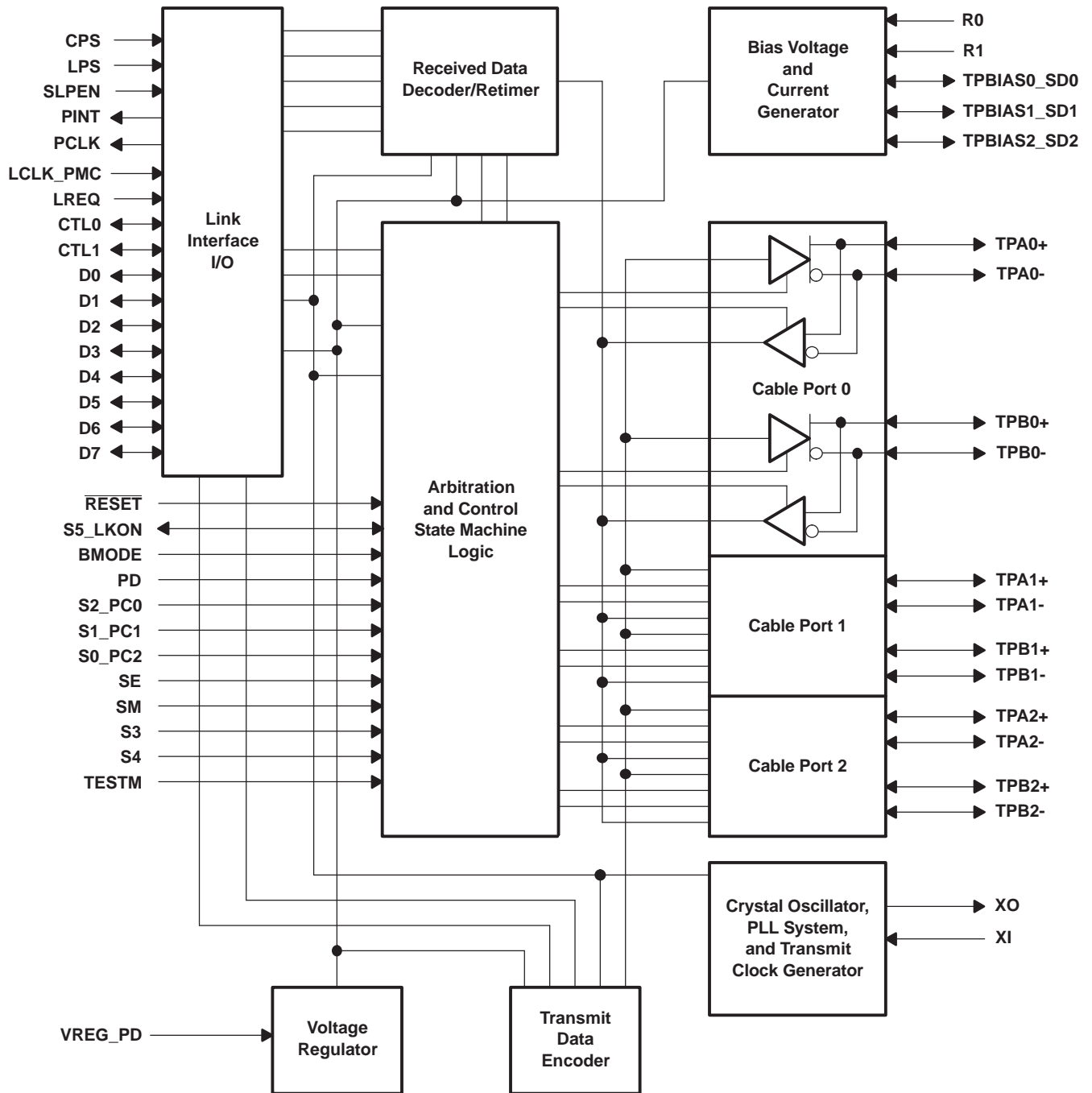

Table 1. Terminal Functions

TERMINAL			I/O	DESCRIPTION
NAME	TYPE	PFP NO.		
AGND	Supply	21, 40, 43, 50, 61, 62	–	Analog circuit ground terminals. These terminals must be tied together to the low-impedance circuit board ground plane.
AVDD	Supply	24, 39, 44, 51, 57, 63	–	Analog circuit power terminals. A combination of high-frequency decoupling capacitors near each terminal is suggested, such as paralleled 0.1 μF and 0.001 μF . Lower frequency 10- μF filtering capacitors are also recommended. These supply terminals are separated from the PLLVDD-CORE, PLLVDD-3.3, DVDD-CORE, and DVDD-3.3 terminals internal to the device to provide noise isolation. The PLLVDD-3.3, AVDD, and DVDD-3.3 terminals must be tied together with a low dc impedance connection on the circuit board.
BMODE	CMOS	74	I	Beta-mode input. This terminal determines the PHY-link interface connection protocol. When logic-high (asserted), the PHY-link interface complies with the 1394b-2002 B PHY-link interface. When logic-low (deasserted), the PHY-link interface complies with the legacy 1394a-2000 standard. When using an LLC such as the 1394b-2002 TSB82AA2, this terminal must be pulled high. When using an LLC such as the 1394a-2000 TSB12LV26, this terminal must be tied low. NOTE: The PHY-link interface cannot be changed between the different protocols during operation.
CPS	CMOS	34	I	Cable-power status input. This terminal is normally connected to cable power through a 400-k Ω resistor. This circuit drives an internal comparator that detects the presence of cable power. This transition from cable power sensed to cable power not sensed can be used to generate an interrupt to the LLC.
CTL0 CTL1	CMOS	9 10	I/O	Control I/Os. These bidirectional signals control communication between the TSB41BA3D and the LLC. Bus holders are built into these terminals.
D0–D7	CMOS	11, 12, 13, 15, 16, 17, 19, 20	I/O	Data I/Os. These are bidirectional data signals between the TSB82BA3 and the LLC. Bus holders are built into these terminals. If power management control (PMC) is selected using LCLK_PMC, then some of these terminals can be used for PMC. See the LCLK_PMC terminal description for more information.
DGND	Supply	4, 14, 38, 64, 72, 76		Digital circuit ground terminals. These terminals must be tied together to the low-impedance circuit board ground plane.
DVDD-CORE	Supply	8, 37, 65, 71	–	Digital core circuit power terminals. A combination of high-frequency decoupling capacitors near each terminal is suggested, such as paralleled 0.1 μF and 0.001 μF . An additional 1- μF capacitor is required for voltage regulation. These supply terminals are separated from the DVDD-3.3, PLLVDD-CORE, PLLVDD-3.3, and AVDD terminals internal to the device to provide noise isolation.
DVDD-3.3	Supply	6, 18, 69, 70	–	Digital 3.3-V circuit power terminals. A combination of high-frequency decoupling capacitors near each terminal is suggested, such as paralleled 0.1 μF and 0.001 μF . Lower-frequency 10- μF filtering capacitors are also recommended. The DVDD-3.3 terminals must be tied together at a low-impedance point on the circuit board. These supply terminals are separated from the PLLVDD-CORE, PLLVDD-3.3, DVDD-CORE, and AVDD terminals internal to the device to provide noise isolation. The PLLVDD-3.3, AVDD, and DVDD-3.3 terminals must be tied together with a low dc impedance connection on the circuit board.

Table 1. Terminal Functions (continued)

TERMINAL			I/O	DESCRIPTION																
NAME	TYPE	PFP NO.																		
LCLK_PMC	CMOS	7	I	<p>Link clock. Link-provided 98.304-MHz clock signal to synchronize data transfers from link to the PHY. On hardware reset, this terminal is sampled to determine the power management control (PMC) mode.</p> <table border="1"> <thead> <tr> <th>LCLK_PMC</th> <th>LPS</th> <th>BMODE</th> <th>Mode</th> </tr> </thead> <tbody> <tr> <td>H</td> <td>L</td> <td>H</td> <td>No LLC (PMC mode)</td> </tr> <tr> <td>n/c⁽¹⁾</td> <td>lps</td> <td>L</td> <td>Legacy LLC</td> </tr> <tr> <td>LCLK_PMC⁽²⁾</td> <td>lps</td> <td>H</td> <td>Beta LLC</td> </tr> </tbody> </table> <p>In PMC mode, because no LLC is attached, the data lines (D7–D0) are available to indicate power states. In PMC mode, the following signals are output:</p> <ul style="list-style-type: none"> D0—port 0 cable-power disable (see Note) D1—port 1 cable-power disable (port in sleep or disabled) D2—port 2 cable-power disable (port in sleep or disabled) D6—All ports cable-power disable (all ports in sleep/disabled) logical AND of bits D0–D2 D3–D5 and D7 are reserved for future use. <p>NOTE: The cable-power disable is asserted when the port is either:</p> <ul style="list-style-type: none"> Hard-disabled (both the disabled and hard-disabled bits are set) Sleep-disabled (both the disabled and sleep_enable bits are set) Disconnected Asleep Connected in DS mode, but nonactive (that is, suspended or disabled) <p>Otherwise, the cable-power disable output is deasserted (that is, cable power is enabled) when the port is dc-connected or active. A bus holder is built into this terminal.</p>	LCLK_PMC	LPS	BMODE	Mode	H	L	H	No LLC (PMC mode)	n/c ⁽¹⁾	lps	L	Legacy LLC	LCLK_PMC ⁽²⁾	lps	H	Beta LLC
LCLK_PMC	LPS	BMODE	Mode																	
H	L	H	No LLC (PMC mode)																	
n/c ⁽¹⁾	lps	L	Legacy LLC																	
LCLK_PMC ⁽²⁾	lps	H	Beta LLC																	
LPS	CMOS	80	I	<p>Link power status input. This terminal monitors the active/power status of the link-layer controller (LLC) and controls the state of the PHY-LLC interface. This terminal must be connected to either the V_{DD} supplying the LLC through an approximately 1-kΩ resistor or to a pulsed output which is active when the LLC is powered. A pulsed signal must be used when an isolation barrier exists between the LLC and PHY (see Figure 8).</p> <p>The LPS input is considered inactive if it is sampled low by the PHY for more than an LPS_RESET time (~2.6 μs), and is considered active otherwise (that is, asserted steady high or an oscillating signal with a low time less than 2.6 μs). The LPS input must be high for at least 22 ns to be observed as high by the PHY.</p> <p>When the TSB41BA3D detects that the LPS input is inactive, it places the PHY-LLC interface into a low-power reset state. In the reset state, the CTL (CTL0 and CTL1) and D (D0 to D7) outputs are held in the logic 0 state and the LREQ input is ignored; however, the PCLK output remains active. If the LPS input remains low for more than an LPS_DISABLE time (~26 μs), then the PHY-LLC interface is put into a low-power disabled state in which the PCLK output is also held inactive.</p> <p>The LLC state that is communicated in the self-ID packet is considered active only if both the LPS input is active and the LCtrl register bit is set to 1. The LLC state that is communicated in the self-ID packet is considered inactive if either the LPS input is inactive or the LCtrl register bit is cleared to 0.</p>																
LREQ	CMOS	3	I	<p>LLC request input. The LLC uses this input to initiate a service request to the TSB41BA3D. A bus holder is built into this terminal.</p>																
PCLK	CMOS	5	O	<p>PHY clock. Provides a 98.304-MHz clock signal, synchronized with data transfers, to the LLC when the PHY-link interface is operating in the 1394b mode (BMODE asserted). PCLK output provides a 49.152-MHz clock signal, synchronized with data transfers, to the LLC when the PHY-link interface is in legacy 1394a-2000 (BMODE input deasserted).</p>																
PD	CMOS	77	I	<p>Power-down input. A high on this terminal turns off all internal circuitry. Asserting the PD input high also activates an internal pulldown on the RESET terminal to force a reset of the internal control logic.</p>																
PINT	CMOS	1	O	<p>PHY interrupt. The PHY uses this output to serially transfer status and interrupt information to the link when PHY-link interface is in the 1394b mode. A bus holder is built into this terminal.</p>																

(1) Internal pulldown on LCLK_PMC
 (2) LCLK_PMC from LLC normally low during reset

Table 1. Terminal Functions (continued)

TERMINAL			I/O	DESCRIPTION
NAME	TYPE	PFP NO.		
PLLGNDD	Supply	25, 28	–	PLL circuit ground terminals. These terminals must be tied together to the low-impedance circuit board ground plane.
PLLVDD-CORE	Supply	29, 30	–	PLL core circuit power terminals. A combination of high-frequency decoupling capacitors near each terminal is suggested, such as paralleled 0.1 μ F and 0.001 μ F. An additional 1- μ F capacitor is required for voltage regulation. The PLLVDD-CORE terminals must be separate from the DVDD-CORE terminals. These supply terminals are separated from the DVDD-CORE, DVDD-3.3, PLLVDD-3.3, and AVDD-3.3 terminals internal to the device to provide noise isolation.
PLLVDD-3.3	Supply	31	–	PLL 3.3-V circuit power terminal. A combination of high-frequency decoupling capacitors near the terminal are suggested, such as paralleled 0.1 μ F and 0.001 μ F. Lower frequency 10- μ F filtering capacitors are also recommended. This supply terminal is separated from the DVDD-CORE, DVDD-3.3, PLLVDD-CORE, and AVDD-3.3 terminals internal to the device to provide noise isolation. The DVDD-3.3 terminals must be tied together at a low-impedance point on the circuit board. The PLLVDD-3.3, AVDD-3.3, and DVDD-3.3 terminals must be tied together with a low dc impedance connection.
RESET	CMOS	75	I	Logic reset input. Asserting this terminal low resets the internal logic. An internal pullup resistor to V_{DD} is provided so only an external delay capacitor is required for proper power-up operation (see <i>power-up reset</i> in the <i>Application Information</i> section). The RESET terminal also incorporates an internal pulldown which is activated when the PD input is asserted high. This input is otherwise a standard logic input, and can also be driven by an open-drain-type driver.
R0 R1	Bias	23 22	–	Current setting resistor terminals. These terminals are connected to a precision external resistance to set the internal operating currents and cable driver output currents. A resistance of 6.34 k Ω \pm 1% is required to meet the IEEE Std 1394-1995 output voltage limits.
SE	CMOS	35	I	Test control input. This input is used in the manufacturing test of the TSB41BA3D. For normal use, this terminal must be pulled low either through a 1-k Ω resistor to GND or directly to GND.
SLPEN	CMOS	79	I	Automotive sleep mode enable input. This terminal enables the automotive sleep mode. When deasserted (logic-low), normal 1394.b functionality is maintained.
SM	CMOS	36	I	Test control input. This input is used in the manufacturing test of the TSB41BA3D. For normal use this terminal must be pulled low either through a 1-k Ω resistor to GND or directly to GND.
S2_PC0 S1_PC1 S0_PC2	CMOS	66 67 68	I	Port sleep/mode selection terminals 2-0 and power-class programming. On hardware reset, this terminal when used with the other five selection terminals allows the user to select the speed and mode of the ports. See Table 2 . Depending on the selection, these inputs can set the default value of the power class indicated during self-ID. Programming is done by tying the terminals high through a 1-k Ω or smaller resistor or by tying directly to ground through a 1-k Ω or smaller resistor. Bus holders are built into these terminals.
S3	CMOS	33	I	Port sleep/mode selection terminal 3. On hardware reset, this terminal when used with the other five selection terminals allows the user to select the speed and mode of the ports. See Table 2 . Programming is done by tying the terminals high through a 1-k Ω or smaller resistor or by tying directly to ground through a 1-k Ω or smaller resistor. A bus holder is built into this terminal.
S4	CMOS	32	I	Port sleep/mode selection terminal 4. On hardware reset, this terminal when used with the other five selection terminals allows the user to select the speed and mode of the ports. See Table 2 . Programming is done by tying the terminals high through a 1-k Ω or smaller resistor or by tying directly to ground through a 1-k Ω or smaller resistor. A bus holder is built into this terminal.

Table 1. Terminal Functions (continued)

TERMINAL			I/O	DESCRIPTION
NAME	TYPE	PFP NO.		
S5_LKON	CMOS	2	I/O	<p>Port sleep/mode selection terminal 5 and link-on output. This terminal can be connected to the link-on input terminal of the LLC through a 1-kΩ resistor if the link-on input is available on the link layer.</p> <p>On hardware reset this terminal, when used with the other Port Speed/Mode Selection terminals, allows the user to select whether ports act like a 1394b bilingual port (terminal at logic 0) or as a 1394a-2000-only port (terminal 1394b bilingual mode or high through a 1-kΩ or less resistor to enable 1394b bilingual mode or high through a 1-kΩ or less resistor to enable 1394a-2000-only mode. A bus holder is built into this terminal. See Table 2. A bus holder is built into this terminal.</p> <p>After hardware reset, this terminal is the link-on output, which notifies the LLC or other power-up logic to power up and become active. The link-on output is a square wave signal with a period of approximately 163 ns (8 PCLK cycles) when active. The link-on output is otherwise driven low, except during hardware reset when it is high-impedance.</p> <p>The link-on output is activated if the LLC is inactive (the LPS input inactive or the LCtrl bit cleared) and when one of the following occurs:</p> <ol style="list-style-type: none"> The PHY receives a link-on PHY packet addressed to this node. The PEI (port-event interrupt) register bit is 1. Any of the CTOI (configuration-timeout interrupt), CPSI (cable-power-status interrupt), or STOI (state-time-out interrupt) register bits is 1 and the RPIE (resuming-port interrupt enable) register bit is also 1. The PHY is power-cycled and the power class is 0 through 4. <p>Once activated, the link-on output is active until the LLC becomes active (both the LPS input active and the LCtrl bit set). The PHY also deasserts the link-on output when a bus-reset occurs unless the link-on output is otherwise active because one of the interrupt bits is set (that is, the link-on output is active due solely to the reception of a link-on PHY packet).</p> <p>In the case of power-cycling the PHY, the LKON signal must stop after 167 s if the preceding conditions have not been met.</p> <p>NOTE: If an interrupt condition exists which otherwise would cause the link-on output to be activated if the LLC were inactive, then the link-on output is activated when the LLC subsequently becomes inactive.</p>
TESTM	CMOS	78	I	<p>Test control input. This input is used in the manufacturing test of the TSB41BA3D. For normal use this terminal must be pulled high through a 1-kΩ resistor to V_{DD}.</p>
TPA0– TPA0+ TPB0– TPB0+	Cable	45 46 41 42	I/O	<p>Port-0 twisted-pair differential-signal terminals. Board traces from each pair of positive and negative differential signal terminals must be kept matched and as short as possible to the external load resistors and to the cable connector. Request the S800 1394b layout recommendations document from your Texas Instruments representative.</p>
TPA1– TPA1+ TPB1– TPB1+	Cable	52 53 48 49	I/O	<p>Port-1 twisted-pair differential-signal terminals. Board traces from each pair of positive and negative differential signal terminals must be kept matched and as short as possible to the external load resistors and to the cable connector. Request the S800 1394b layout recommendations document from your Texas Instruments representative.</p>
TPA2– TPA2+ TPB2– TPB2+	Cable	58 59 55 56	I/O	<p>Port-2 twisted-pair differential-signal terminals. Board traces from each pair of positive and negative differential signal terminals must be kept matched and as short as possible to the external load resistors and to the cable connector. Request the S800 1394b layout recommendations document from your Texas Instruments representative.</p>
TPBIAS0_SD0 TPBIAS1_SD1 TPBIAS2_SD2	Cable In	47 54 60	I/O	<p>Twisted-pair bias output and signal detect input. This provides the 1.86-V nominal bias voltage needed for proper operation of the twisted-pair cable drivers and receivers, and for signaling to the remote nodes that there is an active cable connection in 1394a-2000 mode. Each of these terminals, except for an unused port, must be decoupled with a 1-μF capacitor to ground. For the unused port, this terminal can be left unconnected.</p> <p>When a port is configured as a Beta-mode port (B1, B2, B4) this terminal becomes an input and must be high when a valid signal is present. For optical transceivers, the signal detect of the transceiver must be connected to this terminal. The input is an LVCMOS level input.</p>
VREG_PD	CMOS	73	I	<p>Voltage regulator power-down input. When asserted logic-high, this terminal powers down the internal 3.3-V-to-1.8-V regulator. For single-supply (3.3-V only) operation, this terminal must be tied to GND.</p>

Table 1. Terminal Functions (continued)

TERMINAL			I/O	DESCRIPTION
NAME	TYPE	PFP NO.		
XI XO	Crystal	27 26	I O	Crystal oscillator inputs. These terminals connect to a 49.152-MHz parallel-resonant fundamental-mode crystal. The optimum values for the external shunt capacitors depend on the specifications of the crystal used (see the <i>crystal selection</i> section in the <i>TSB41AB3 IEEE 1394a-2000 Three-Port Cable Transceiver/Arbiter</i> data sheet, SLLS418. XI is a 1.8-V CMOS input.

Table 2. Port Speed/Mode Selection

MOD E NO.	INPUT SELECTION						RESULTING PORT, POWER CLASS, AND SELF-ID							
	S5_LKON	S4	S3	S2_PC0	S1_PC1	S0_PC2	PORT ⁽¹⁾						POWER CLASS	SELF-ID
							2		1		0			
1	0	0	0	PC0	PC1	PC2	Bi	T	Bi	T	Bi	T	PC = (PC0, PC1, PC2)	1394b
2	0	0	1	PC0	PC1	PC2	DS	T	Bi	T	Bi	T	PC = (PC0, PC1, PC2)	1394b
3	0	1	0	PC0	PC1	PC2	DS	T	DS	T	Bi	T	PC = (PC0, PC1, PC2)	1394b
4	0	1	1	0	0	0	B1	S	B1	S	B1	S	PC = 000	1394b
5	0	1	1	0	0	1	B2	S	B2	S	B2	S	PC = 000	1394b
6	0	1	1	0	1	0	B4	S	B4	S	B4	S	PC = 000	1394b
7	0	1	1	0	1	1	B2	S	Bi	T	B4	S	PC = 100	1394b
8	0	1	1	1	0	0	B1	S	DS	T	DS	T	PC = 100	1394a S100 ⁽²⁾
9	0	1	1	1	0	1	DS	T	DS	T	B2	S	PC = 100	1394b
10	0	1	1	1	1	0	DS	T	DS	T	B4	S	PC = 100	1394b
11	0	1	1	1	1	1	B2	S	DS	T	B4	S	PC = 100	1394b
12	1	0	0	PC0	0	0	B1	S	Bi	T	B1	S	PC = PC0,0,0 (100 or 000)	1394b
13	1	0	0	PC0	0	1	B2	S	Bi	T	B2	S	PC = PC0,0,0 (100 or 000)	1394b
14	1	0	0	PC0	1	0	B4	S	Bi	T	B4	S	PC = PC0,0,0 (100 or 000)	1394b
15	1	0	0	PC0	1	1	B1	S	Bi	T	B2	S	PC = PC0,0,0 (100 or 000)	1394b
16	1	0	1	PC0	0	0	Bi	T	Bi	T	B1	S	PC = PC0,0,0 (100 or 000)	1394b
17	1	0	1	PC0	0	1	Bi	T	Bi	T	B2	S	PC = PC0,0,0 (100 or 000)	1394b
18	1	0	1	PC0	1	0	Bi	T	Bi	T	B4	S	PC = PC0,0,0 (100 or 000)	1394b
19	1	0	1	PC0	1	1	B1	S	Bi	T	B4	S	PC = PC0,0,0 (100 or 000)	1394b
20	1	1	0	PC0	0	0	DS	T	Bi	T	B1	S	PC = PC0,0,0 (100 or 000)	1394b
21	1	1	0	PC0	0	1	DS	T	Bi	T	B2	S	PC = PC0,0,0 (100 or 000)	1394b
22	1	1	0	PC0	1	0	DS	T	Bi	T	B4	S	PC = PC0,0,0 (100 or 000)	1394b
23	1	1	0	PC0	1	1	B1	S	DS	T	B2	S	PC = PC0,0,0 (100 or 000)	1394b
24	1	1	1	PC0	0	0	B1	S	DS	T	B1	S	PC = PC0,0,0 (100 or 000)	1394b
25	1	1	1	PC0	0	1	B2	S	DS	T	B2	S	PC = PC0,0,0 (100 or 000)	1394b
26	1	1	1	PC0	1	0	B4	S	DS	T	B4	S	PC = PC0,0,0 (100 or 000)	1394b
27	1	1	1	PC0	1	1	B1	S	DS	T	B4	S	PC = PC0,0,0 (100 or 000)	1394b

- (1) LEGEND:
 Bi = 1394b-2002 bilingual (S400b only Beta operating speed and data strobe: S400, S200, and S100 operating speeds)
 DS = 1394a-2000, data strobe-only, S400, S200, and S100 operating speeds
 B1 = 1394b-2002 Beta-only, S100b operating speed
 B2 = 1394b-2002 Beta-only, S200b and S100b operating speeds
 B4 = 1394b-2002 Beta-only, S400b, S200b, and S100b operating speeds
 S = TPBIAS#_SD# terminal is in signal detect input mode
 T = TPBIAS#_SD# terminal is in TPBIAS output mode
- (2) Mode 8 must only be used to do an S100 home network translation. It must not be used as a nominal end equation mode.

PORT MODE/SPEED SELECTION EXAMPLE CONNECTIONS

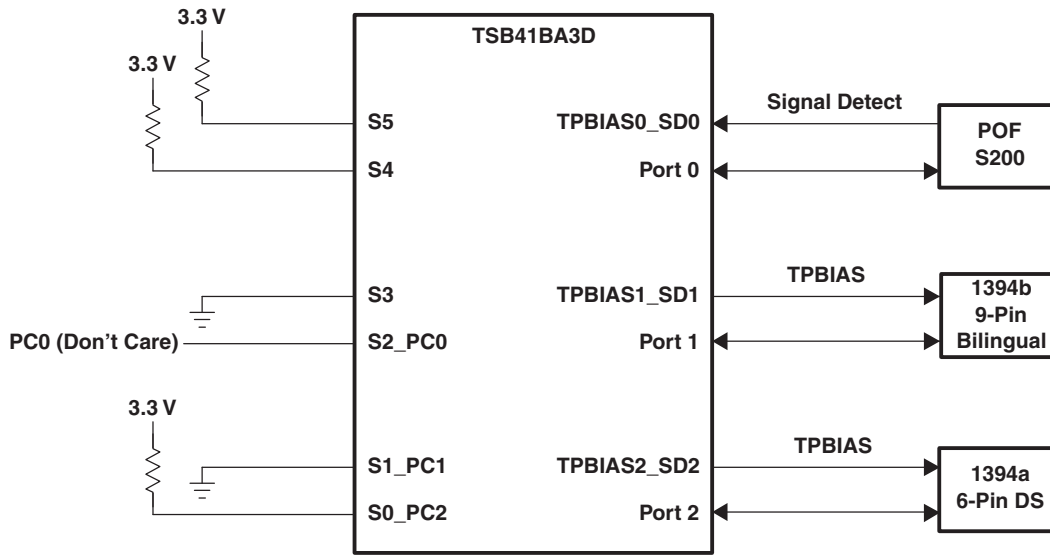

Mode 21, Port/Speed Mode (1, 1, 0, PC0, 0, 1)

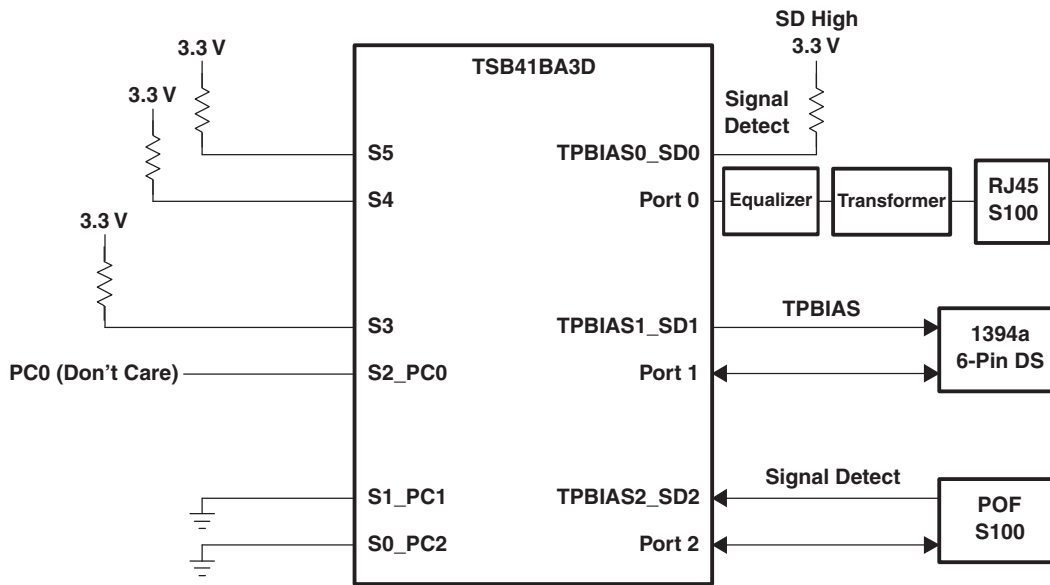

Mode 24, Port/Speed Mode (1, 1, 1, PC0, 0, 0)

ABSOLUTE MAXIMUM RATINGS⁽¹⁾

over operating free-air temperature (unless otherwise noted)

		MIN	MAX	UNIT
V _{DD}	Supply voltage range ⁽²⁾	–0.3	4	V
V _I	Input voltage range ⁽²⁾	–0.5	V _{DD} + 0.5	V
V _O	Output voltage range at any output	–0.5	V _{DD} + 0.5	V
Continuous total power dissipation		See Table 3		
T _A	Operating free-air temperature	TSB41BA3D		°C
		TSB41BA3DI		
T _{stg}	Storage temperature range	–65	150	°C
Lead temperature 1,6 mm (1/16 inch) from case for 10 seconds			260	°C

- (1) Stresses beyond those listed under "absolute maximum ratings" may cause permanent damage to the device. These are stress ratings only, and functional operation of the device at these or any other conditions beyond those indicated under "recommended operating conditions" is not implied. Exposure to absolute-maximum-rated conditions for extended periods may affect device reliability.
- (2) All voltage values, except differential I/O bus voltages, are with respect to network ground.

Table 3. DISSIPATION RATINGS

PACKAGE	T _A ≤ 25°C POWER RATING	DERATING FACTOR ⁽¹⁾ ABOVE T _A = 25°C	T _A = 70°C POWER RATING	T _A = 85°C POWER RATING
PFP ⁽²⁾	5.05 W	52.5 mW/C	2.69 W	1.9 W
PFP ⁽³⁾	3.05 W	31.7 mW/C	1.62 W	1.15 W
PFP ⁽⁴⁾	2.01 W	20.3 mW/C	1.1 W	1.1 W

- (1) This is the inverse of the traditional junction-to-ambient thermal resistance (R_{θJA}).
- (2) 2-oz. trace and copper pad with solder.
- (3) 2-oz. trace and copper pad without solder.
- (4) For more information, see the Texas Instruments application note *PowerPAD™ Thermally Enhanced Package* (SLMA002).

RECOMMENDED OPERATING CONDITIONS

		MIN	TYP ⁽¹⁾	MAX	UNIT
Supply voltage, 3.3 V _{DD}	Source power node	3	3.3	3.6	V
	Nonsource power node	3 ⁽²⁾	3.3	3.6	
Supply voltage, 1.8 V _{DD}	TSB41BA3D	1.7	1.85	2	V
	TSB41BA3DI	1.75	1.85	2	
High-level input voltage, V _{IH}	LREQ, CTL0, CTL1, D0–D7, LCLK_PMC	2.6			V
	S5_LKON, S4, S3, S2_PC0, S1_PC1, S0_PC2, SLPEN, PD, BMODE, TPBIAS0_SD0, TPBIAS1_SD1, TPBIAS2_SD2	0.7 V _{DD}			
	RESET	0.6 V _{DD}			
Low-level input voltage, V _{IL}	LREQ, CTL0, CTL1, D0–D7, LCLK_PMC	1.2			V
	S5_LKON, S4, S3, S2_PC0, S1_PC1, S0_PC2, SLPEN, PD, BMODE, TPBIAS0_SD0, TPBIAS1_SD1, TPBIAS2_SD2	0.2 V _{DD}			
	RESET	0.3 V _{DD}			
Output current, I _{OL/OH}	CTL0, CTL1, D0–D7, S5_LKON, PINT, PCLK	–4		4	mA
Output current, I _O	TPBIAS outputs	–5.6		1.3	mA
Maximum junction temperature, T _J (see R _{θJA} values listed in thermal characteristics table)	R _{θJA} = 19°C/W, T _A = 70°C			84.1	°C
	R _{θJA} = 31.5°C/W, T _A = 70°C			93.3	
	R _{θJA} = 49.2°C/W, T _A = 70°C			106.4	
	R _{θJA} = 19°C/W, T _A = 85°C			99.1	
	R _{θJA} = 31.5°C/W, T _A = 85°C			108.4	
	R _{θJA} = 49.2°C/W, T _A = 85°C			121.5	
1394b Differential input voltage, V _{ID}	Cable inputs, during data reception	200		800	mV
1394a Differential input voltage, V _{ID}	Cable inputs, during data reception	118		260	mV
	Cable inputs, during arbitration	168		265	
1394a Common-mode input voltage, V _{IC}	TPB cable inputs, source power node	0.4706		2.515	V
	TPB cable inputs, nonsource power node	0.4706		2.015 ⁽²⁾	
Power-up reset time, t _{pu}	RESET input	2 ⁽³⁾			ms
1394a receive input jitter	TPA, TPB cable inputs, S100 operation	±1.08			ns
	TPA, TPB cable inputs, S200 operation	0.5			
	TPA, TPB cable inputs, S400 operation	±0.315			
1394a receive input skew	Between TPA and TPB cable inputs, S100 operation	±0.8			ns
	Between TPA and TPB cable inputs, S200 operation	±0.55			
	Between TPA and TPB cable inputs, S400 operation	±0.5			

(1) All typical values are at V_{DD} = 3.3 V and T_A = 25°C.

(2) For a node that does not source power, see Section 4.2.2.2 in IEEE 1394a-2000.

(3) Time after valid clock received at PHY XI input terminal.

ELECTRICAL CHARACTERISTICS

Driver

over recommended ranges of operating conditions (unless otherwise noted)

PARAMETER		TEST CONDITION	MIN	TYP	MAX	UNIT
V _{OD}	1394a differential output voltage	56 Ω, See Figure 1	172		265	mV
V _{OD}	1394b differential output voltage		300	700	800	mV
I _{DIFF}	Driver difference current, TPA+, TPA–, TPB+, TPB–	Drivers enabled, speed signaling off	–1.05 ⁽¹⁾		1.05 ⁽¹⁾	mA
I _{SP200}	Common-mode speed signaling current, TPB+, TPB–	S200 speed signaling enabled	–4.84 ⁽²⁾		–2.53 ⁽²⁾	mA
I _{SP400}	Common-mode speed signaling current, TPB+, TPB–	S400 speed signaling enabled	–12.4 ⁽²⁾		–8.1 ⁽²⁾	mA
V _{OFF}	Off-state differential voltage	Drivers disabled, See Figure 1			20	mV

- (1) Limits defined as algebraic sum of TPA+ and TPA– driver currents. Limits also apply to TPB+ and TPB– algebraic sum of driver currents.
 (2) Limits defined as absolute limit of each TPB+ and TPB– driver currents.

Receiver

over recommended ranges of operating conditions (unless otherwise noted)

PARAMETER		TEST CONDITION	MIN	TYP	MAX	UNIT
Z _{ID}	Differential impedance	Drivers disabled	4	7		kΩ
					4	pF
Z _{IC}	Common-mode impedance	Drivers disabled	20			kΩ
					24	pF
V _{TH-R}	Receiver input threshold voltage	Drivers disabled	–30		30	mV
V _{TH-CB}	Cable bias detect threshold, TPBx cable inputs	Drivers disabled	0.6		1	V
V _{TH+}	Positive arbitration comparator threshold voltage	Drivers disabled	89		168	mV
V _{TH–}	Negative arbitration comparator threshold voltage	Drivers disabled	–168		–89	mV
V _{TH-SP200}	Speed signal threshold	TPBIAS–TPA common-mode voltage, drivers disabled	49		131	mV
V _{TH-SP400}	Speed signal threshold		314		396	mV

Device

over recommended ranges of operating conditions (unless otherwise noted)

PARAMETER		TEST CONDITION	MIN	TYP	MAX	UNIT
I _{DD}	Supply current 3.3 V _{DD}	⁽¹⁾		110	150	mA
V _{TH}	Power status threshold, CPS input ⁽²⁾	400-kΩ resistor ⁽²⁾	4.7		7.5	V
V _{OH}	High-level output voltage, CTL0, CTL1, D0–D7, PCLK, S5_LKON outputs	V _{DD} = 3 to 3.6 V, I _{OH} = –4 mA	2.8			V
V _{OL}	Low-level output voltage, CTL0, CTL1, D0–D7, PCLK, S5_LKON outputs	I _{OL} = 4 mA			0.4	V
I _{BH+}	Positive peak bus holder current, D0–D7, CTL0–CTL1, LREQ	V _{DD} = 3.6 V, V _I = 0 V to V _{DD}	0.05		1	mA
I _{BH–}	Negative peak bus holder current, D0–D7, CTL0–CTL1, LREQ	V _{DD} = 3.6 V, V _I = 0 V to V _{DD}	–1.0		–0.05	mA
I _{OZ}	Off-state output current, CTL0, CTL1, D0–D7, S5_LKON I/Os	V _O = V _{DD} or 0 V	TSB41BA3D		±5	μA
			TSB41BA3DI		±20	
I _{IRST}	Pullup current, $\overline{\text{RESET}}$ input	V _I = 1.5 V or 0 V	–90		–20	μA
V _O	TPBIAS output voltage	At rated I _O current	1.665		2.015	V

- (1) Repeat max packet (one port receiving maximum size isochronous packet–4096 bytes, sent on every isochronous interval, data value of 0x00FF 00FFh; two ports repeating; all ports with S400 Beta-mode connection), V_{DD3.3} = 3.3 V, internal regulator, T_A = 25°C
 (2) Measured at cable-power side of resistor

THERMAL CHARACTERISTICS

PARAMETER		TEST CONDITION	MIN	TYP	MAX	UNIT
$R_{\theta JA}$	Junction-to-free-air thermal resistance	Board-mounted, no air flow, high conductivity Texas Instruments-recommended test board, chip soldered or greased to thermal land with 2-oz. copper.	19.04			°C/W
$R_{\theta JC}$	Junction-to-case-thermal resistance		0.17			°C/W
$R_{\theta JA}$	Junction-to-free-air thermal resistance	Board-mounted, no air flow, high-conductivity Texas Instruments recommended test board with thermal land but no solder or grease thermal connection to thermal land with 2-oz. copper.	31.52			°C/W
$R_{\theta JC}$	Junction-to-case-thermal resistance		0.17			°C/W
$R_{\theta JA}$	Junction-to-free-air thermal resistance	Board-mounted, no air flow, high-conductivity JEDEC test board with 1-oz. copper	49.17			°C/W
$R_{\theta JC}$	Junction-to-case-thermal resistance		3.11			°C/W
$R_{\theta JA}$	Junction-to-free-air thermal resistance	Two-sided JEDEC test card, no air flow	52.66			°C/W

SWITCHING CHARACTERISTICS

PARAMETER		TEST CONDITION	MIN	TYP	MAX	UNIT	
t_r	TP differential rise time, transmit	1394a-2000	10% to 90%, At 1394 connector	0.3		0.8	ns
		1394a-2000 S400B		80		800	ps
t_f	TP differential fall time, transmit	1394a-2000	90% to 10%, At 1394 connector	0.3		0.8	ns
		1394a-2000 S400B		80		800	ps
t_{su}	Setup time, CTL0, CTL1, D1–D7, LREQ to PCLK	1394a-2000	50% to 50%, See Figure 2		2.5	ns	
t_h	Hold time, CTL0, CTL1, D1–D7, LREQ after PCLK	1394a-2000	50% to 50%, See Figure 2		0	ns	
t_{su}	Setup time, CTL0, CTL1, D1–D7, LREQ to LCLK_PMC	1394b	50% to 50%, See Figure 2		2.5	ns	
t_h	Hold time, CTL0, CTL1, D1–D7, LREQ after LCLK_PMC	1394b	50% to 50%, See Figure 2		0	ns	
t_d	Delay time, PCLK to CTL0, CTL1, D1–D7, PINT	1394a-2000 and 1394b	50% to 50%, See Figure 3		0.5	7	ns

PARAMETER MEASUREMENT INFORMATION

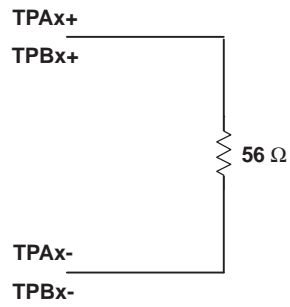

Figure 1. Test Load Diagram

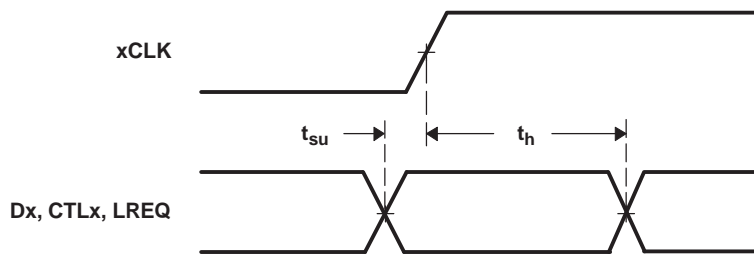

Figure 2. Dx, CTLx, LREQ Input Setup and Hold Time Waveforms

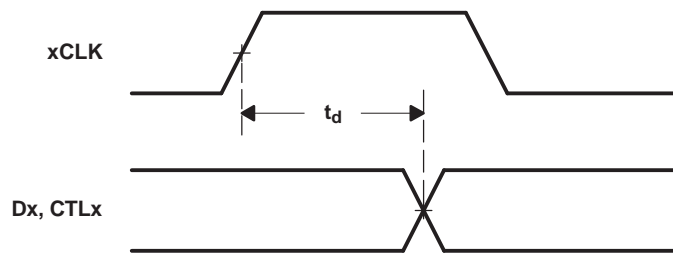

Figure 3. Dx and CTLx Output Delay Relative to xCLK Waveforms

APPLICATION INFORMATION

Obtain reference schematics, reference layouts, debug documents, and software recommendations for the TSB41BA3D from the Texas Instruments website or your local Texas Instruments representative.

Internal Register Configuration

The TSB41BA3D has 16 accessible internal registers. The configuration of the registers at addresses 0h through 7h (the base registers) is fixed, whereas the configuration of the registers at addresses 8h through Fh (the paged registers) depends on which of eight pages, numbered 0h through 7h, is currently selected. The selected page is set in base register 7h. Note that while this register set is compatible with 1394a-2000 register sets, some fields have been redefined, and this register set contains additional fields.

Table 4 shows the configuration of the base registers, and Table 5 gives the corresponding field descriptions. The base register field definitions are unaffected by the selected page number.

A reserved register or register field (marked as Reserved or Rsvd in the following register configuration tables) is read as 0, but is subject to future usage. All registers in address pages 2 through 6 are reserved.

Table 4. Base Register Configuration

Address	BIT POSITION							
	0	1	2	3	4	5	6	7
0000	Physical ID						R	CPS
0001	RHB	IBR	Gap_Count					
0010	Extended (111b)			Num_Ports (0011b)				
0011	PHY_Speed (111b)			SREN	Delay (1111b)			
0100	LCtrl	C	Jitter (000b)			Pwr_Class		
0101	WDIE	ISBR	CTOI	CPSI	STOI	PEI	EAA	EMC
0110	Max Legacy SPD			BLINK	Bridge		Rsvd	
0111	Page_Select			Rsvd	Port_Select			

Table 5. Base Register Field Descriptions

FIELD	SIZE	TYPE	DESCRIPTION
Physical ID	6	Rd	This field contains the physical address ID of this node determined during self-ID. The physical-ID is invalid after a bus reset until the self-ID has completed as indicated by an unsolicited register 0 status transfer from the PHY to the LLC.
R	1	Rd	Root. This bit indicates that this node is the root node. The R bit is reset to 0 by bus reset, and is set to 1 during tree-ID if this node becomes root.
CPS	1	Rd	Cable-power status. This bit indicates the state of the CPS input terminal. The CPS terminal is normally tied to serial bus cable power through a 400-kΩ resistor. A 0 in this bit indicates that the cable-power voltage has dropped below its threshold for ensured reliable operation.
RHB	1	Rd/Wr	Root-holdoff bit. This bit instructs the PHY to attempt to become root after the next bus reset. The RHB bit is reset to 0 by a hardware reset and is unaffected by a bus reset. If two nodes on a single bus have their root holdoff bit set, then the result is not defined. To prevent two nodes from having their root-holdoff bit set, this bit must only be written using a PHY configuration packet.
IBR	1	Rd/Wr	Initiate bus reset. This bit instructs the PHY to initiate a long (166-μs) bus reset at the next opportunity. Any receive or transmit operation in progress when this bit is set completes before the bus reset is initiated. The IBR bit is reset to 0 after a hardware reset or a bus reset. Care must be exercised when writing to this bit to not change the other bits in this register. It is recommended that whenever possible a bus reset be initiated using the ISBR bit and not the IBR bit.
Gap_Count	6	Rd/Wr	Arbitration gap count. This value sets the subaction (fair) gap, arb-reset gap, and arb-delay times. The gap count can be set either by a write to the register, or by reception or transmission of a PHY_CONFIG packet. The gap count is reset to 3Fh by hardware reset or after two consecutive bus resets without an intervening write to the gap count register (either by a write to the PHY register or by a PHY_CONFIG packet). It is strongly recommended that this field only be changed using PHY configuration packets.
Extended	3	Rd	Extended register definition. For the TSB41BA3D, this field is 111b, indicating that the extended register set is implemented.

Table 5. Base Register Field Descriptions (continued)

FIELD	SIZE	TYPE	DESCRIPTION
Num_Ports	4	Rd	Number of ports. This field indicates the number of ports implemented in the PHY. For the TSB41BA3D, this field is 3.
PHY_Speed	3	Rd	PHY speed capability. This field is no longer used. For the TSB41BA3D PHY, this field is 111b. Speeds for 1394b PHYs must be checked on a port-by-port basis.
SREN	1	Rd/Wr	Standby/restore enable. This bit when set to 1 enables the port to go into the standby reduced power state when commanded by a Standby PHY command packet. This enable works for all ports of the local device. Note the 1394b standard only allows leaf (one port connected) nodes to be placed into standby mode.
Delay	4	Rd	PHY repeater data delay. This field indicates the worst-case repeater data delay of the PHY, expressed as $144+(\text{delay} \times 20)$ ns. For the TSB41BA3D, this field is Fh. The worst-case repeater delay for S100B is 538 ns.
LCtrl	1	Rd/Wr	<p>Link-active status control. This bit controls the indicated active status of the LLC reported in the self-ID packet. The logical AND of this bit and the LPS active status is replicated in the L field (bit 9) of the self-ID packet. The LLC bit in the node self-ID packet is set active only if both the LPS input is active and the LCtrl bit is set.</p> <p>The LCtrl bit provides a software-controllable means to indicate the LLC self-ID active status in lieu of using the LPS input terminal.</p> <p>The LCtrl bit is set to 1 by hardware reset and is unaffected by bus reset.</p> <p>NOTE: The state of the PHY-LLC interface is controlled solely by the LPS input, regardless of the state of the LCtrl bit. If the PHY-LLC interface is operational as determined by the LPS input being active, then received packets and status information continue to be presented on the interface, and any requests indicated on the LREQ input are processed, even if the LCtrl bit is cleared to 0.</p>
C	1	Rd/Wr	Contender status. This bit indicates that this node is a contender for the bus or isochronous resource manager. This bit is replicated in the c field (bit 20) of the self-ID packet. This bit is set to 0 on hardware reset. After hardware reset, this bit can only be set via a software register write. This bit is unaffected by a bus reset.
Jitter	3	Rd	PHY repeater jitter. This field indicates the worst-case difference between the fastest and slowest repeater data delay, expressed as $(\text{jitter}+1) \times 20$ ns. For the TSB41BA3D, this field is 0.
Pwr_Class	3	Rd/Wr	Node power class. This field indicates this node power consumption and source characteristics and is replicated in the pwr field (bits 21–23) of the self-ID packet. This field is reset to the state specified by the S5–S0 input terminals on a hardware reset and is unaffected by a bus reset. See Table 2 and Table 12 .
WDIE	1	Rd/Wr	Watchdog interrupt enable. This bit, if set to 1, enables the port event interrupt (PIE) bit to be set whenever resume operations begin on any port, or when any of the CTOI, CPSI, or STOI interrupt bits are set and the link interface is nonoperational. This bit is reset to 0 by hardware reset and is unaffected by bus reset.
ISBR	1	Rd/Wr	<p>Initiate short arbitrated bus reset. This bit, if set to 1, instructs the PHY to initiate a short (1.3 μs) arbitrated bus reset at the next opportunity. This bit is reset to 0 by a bus reset. It is recommended that short bus reset is the only reset type initiated by software. IEC 61883-6 requires that a node initiate short bus resets to minimize any disturbance to an audio stream.</p> <p>NOTE: Legacy IEEE Std 1394-1995-compliant PHYs are not capable of performing short bus resets. Therefore, initiation of a short bus reset in a network that contains such a legacy device results in a long bus reset being performed.</p>
CTOI	1	Rd/Wr	<p>Configuration time-out interrupt. This bit is set to 1 when the arbitration controller times out during tree-ID start and might indicate that the bus is configured in a loop. This bit is reset to 0 by hardware reset or by writing a 1 to this register bit.</p> <p>If the CTOI and WDIE bits are both set and the LLC is or becomes inactive, then the PHY activates the S5_LKON output to notify the LLC to service the interrupt.</p> <p>NOTE: If the network is configured in a loop, then only those nodes which are part of the loop generate a configuration time-out interrupt. All other nodes instead time out waiting for the tree-ID and/or self-ID process to complete and then generate a state time-out interrupt and bus reset. This bit is only set when the bus topology includes 1394a nodes; otherwise, 1394b loop healing prevents loops from being formed in the topology.</p>
CPSI	1	Rd/Wr	<p>Cable power status interrupt. This bit is set to 1 whenever the CPS input transitions from high to low, indicating that cable power might be too low for reliable operation. This bit is reset to 1 by hardware reset. It can be cleared by writing a 1 to this register bit.</p> <p>If the CPSI and WDIE bits are both set and the LLC is or becomes inactive, then the PHY activates the S5_LKON output to notify the LLC to service the interrupt.</p>

Table 5. Base Register Field Descriptions (continued)

FIELD	SIZE	TYPE	DESCRIPTION
STOI	1	Rd/Wr	State time-out interrupt. This bit indicates that a state time-out has occurred (which also causes a bus reset to occur). This bit is reset to 0 by hardware reset or by writing a 1 to this register bit. If the STOI and WDIE bits are both set and the LLC is or becomes inactive, then the PHY activates the S5_LKON output to notify the LLC to service the interrupt.
PEI	1	Rd/Wr	Port event interrupt. This bit is set to 1 on any change in the connected, bias, disabled, or fault bits for any port for which the port interrupt enable (PIE) bit is set. Additionally, if the resuming port interrupt enable (WDIE) bit is set, then the PEI bit is set to 1 at the start of resume operations on any port. This bit is reset to 0 by hardware reset, or by writing a 1 to this register bit.
EAA	1	Rd/Wr	Enable accelerated arbitration. This bit enables the PHY to perform the various arbitration acceleration enhancements defined in 1394a-2000 (ACK-accelerated arbitration, asynchronous fly-by concatenation, and isochronous fly-by concatenation). This bit is reset to 0 by hardware reset and is unaffected by bus reset. This bit has no effect when the device is operating in 1394b mode. NOTE: The use of accelerated arbitration is completely compatible with networks containing legacy IEEE Std 1394-1995 PHYs. The EAA bit is set only if the attached LLC is 1394a-2000-compliant. If the LLC is not 1394a-2000 or 1394b-2002-compliant, then the use of the arbitration acceleration enhancements can interfere with isochronous traffic by excessively delaying the transmission of cycle-start packets.
EMC	1	Rd/Wr	Enable multispeed concatenated packets. This bit enables the PHY to transmit concatenated packets of differing speeds in accordance with the protocols defined in 1394a-2000. This bit is reset to 0 by hardware reset and is unaffected by bus reset. This bit has no effect when the device is operating in 1394b mode. NOTE: The use of multispeed concatenation is completely compatible with networks containing legacy IEEE Std 1394-1995 PHYs. However, use of multispeed concatenation requires that the attached LLC be 1394a-2000 or 1394b-2002-compliant.
Max Legacy SPD	3	Rd	Maximum legacy-path speed. This field holds the maximum speed capability of any legacy node (1394a-2000 or 1394-1995-compliant) as indicated in the self-ID packets received during bus initialization. Encoding is the same as for the PHY_SPEED field (but limited to S400 maximum).
BLINK	1	Rd	Beta-mode link. This bit indicates that a Beta-mode-capable link is attached to the PHY. This bit is set by the BMODE input terminal on the TSB41BA3D.
Bridge	2	Rd/Wr	This field controls the value of the bridge (brdg) field in self-ID packet. The power reset value is 0. Details for when to set these bits are specified in the IEEE 1394.1 bridging specification.
Page_Select	3	Rd/Wr	Page_Select. This field selects the register page to use when accessing register addresses 8 through 15. This field is reset to 0 by a hardware reset and is unaffected by bus reset.
Port_Select	4	Rd/Wr	Port_Select. This field selects the port when accessing per-port status or control (for example, when one of the port status/control registers is accessed in page 0). Ports are numbered starting at 0. This field is reset to 0 by hardware reset and is unaffected by bus reset.

The port status page provides access to configuration and status information for each of the ports. The port is selected by writing 0 to the Page_Select field and the desired port number to the Port_Select field in base register 7. [Table 6](#) shows the configuration of the port status page registers, and [Table 7](#) gives the corresponding field descriptions. If the selected port is unimplemented, then all registers in the port status page are read as 0.

Table 6. Page 0 (Port Status) Register Configuration

Address	BIT POSITION							
	0	1	2	3	4	5	6	7
1000	Astat		Bstat		Ch	Con	RxOK	Dis
1001	Negotiated_speed			PIE	Fault	Standby_fault	Disscrm	B_Only
1010	DC_connected	Max_port_speed			LPP	Cable_speed		
1011	Connection_unreliable	Reserved			Beta_mode	Reserved		
1100	Port_error							
1101	Reserved			Sleep_Flag	Sleep_enable	Loop_disable	In_standby	Hard_disable
1110	Reserved							
1111	Reserved							

Table 7. Page 0 (Port Status) Register Field Descriptions

FIELD	SIZE	TYPE	DESCRIPTION										
Astat	2	Rd	TPA line state. This field indicates the instantaneous TPA line state of the selected port, encoded as follows: <table border="0" style="margin-left: auto; margin-right: auto;"> <tr> <td style="padding-right: 20px;">Code</td> <td>Arb Value</td> </tr> <tr> <td>11</td> <td>Z</td> </tr> <tr> <td>01</td> <td>1</td> </tr> <tr> <td>10</td> <td>0</td> </tr> <tr> <td>00</td> <td>invalid</td> </tr> </table>	Code	Arb Value	11	Z	01	1	10	0	00	invalid
Code	Arb Value												
11	Z												
01	1												
10	0												
00	invalid												
Bstat	2	Rd	TPB line state. This field indicates the TPB line state of the selected port. This field has the same encoding as the Astat field.										
Ch	1	Rd	Child/parent status. A 1 indicates that the selected port is a child port. A 0 indicates that the selected port is the parent port. A disconnected, disabled, or suspended port is reported as a child port. The Ch bit is invalid after a bus reset until tree-ID has completed.										
Con	1	Rd	Debounced port connection status. This bit indicates that the selected port is connected. The connection must be stable for the debounce time of approximately 341 ms for the Con bit to be set to 1. The Con bit is reset to 0 by hardware reset and is unaffected by bus reset. NOTE: The Con bit indicates that the port is physically connected to a peer PHY, but this does not mean that the port is necessarily active. For 1394b-coupled connections, the Con bit is set when a port detects connection tones from the peer PHY and operating-speed negotiation is completed.										
RxOK	1	Rd	Receive OK. In 1394a-2000 mode this bit indicates the reception of a debounced TPBias signal. In Beta mode, this bit indicates the reception of a continuous electrically valid signal. NOTE: RxOK is set to false during the time that only connection <i>tones</i> are detected in Beta mode.										
Dis	1	Rd/Wr	Port disabled control. If this bit is 1, then the selected port is disabled. The Dis bit is reset to 0 by hardware reset (all ports are enabled for normal operation following hardware reset). The Dis bit is not affected by bus reset. When this bit is set, the port cannot become active; however, the port still tones, but does not establish an active connection.										
Negotiated_speed	3	Rd	Indicates the maximum speed negotiated between this PHY port and its immediately connected port. The encoding is as for Max_port_speed. It is set during connection when in Beta mode or to a value established during self-ID when in 1394a-2000 mode.										
PIE	1	Rd/Wr	Port-event-interrupt enable. When this bit is 1, a port event on the selected port sets the port-event-interrupt (PEI) bit and notifies the link. This bit is reset to 0 by a hardware reset and is unaffected by bus reset.										
Fault	1	Rd/Wr	Fault. This bit indicates that a resume fault or suspend fault has occurred on the selected port, and that the port is in the suspended state. A resume-fault occurs when a resuming port fails to detect incoming cable bias from its attached peer. A suspend fault occurs when a suspending port continues to detect incoming cable bias from its attached peer. Writing 1 to this bit clears the Fault bit to 0. This bit is reset to 0 by hardware reset and is unaffected by bus reset.										
Standby_fault	1	Rd/Wr	This bit is set to 1 if an error is detected during a standby operation and cleared on exit from the standby state. A write of 1 to this bit or receipt of the appropriate remote command packet clears it to 0. When this bit is cleared, standby errors are cleared.										
Disscrm	1	Rd/Wr	Disable scrambler. If this bit is set to 1, then the data sent during packet transmission is not scrambled.										
B_Only	1	Rd	Beta-mode operation only. For the TSB41BA3D, this bit is set to 0 for all ports when all ports are programmed as bilingual or a combination of bilingual and data-strobe (1394a) only. If a port has been programmed to be Beta-only at a selected speed (for example B1 is Beta-only S100), then this bit is set to 1.										
DC_connected	1	Rd	If this bit is set to 1, the port has detected a dc connection to the peer port by means of a 1394a-style connect-detect circuit.										

Table 7. Page 0 (Port Status) Register Field Descriptions (continued)

FIELD	SIZE	TYPE	DESCRIPTION
Max_port_speed	3	Rd/Wr	<p>Max_port_speed</p> <p>The maximum speed at which a port is allowed to operate in Beta mode. The encoding is:</p> <p>000 = S100 001 = S200 010 = S400 011 = S800 100 = S1600 101 = S3200 110 = reserved 111 = reserved</p> <p>An attempt to write to the register with a value greater than the hardware capability of the port results in the maximum value that the port is capable of being stored in the register. The port uses this register only when a new connection is established in the Beta mode or when a port is programmed as a Beta-only port. When a port is programmed as a bilingual port, it is fixed at S400 for the Beta speed and is not updated by a write to this register. The power reset value is the maximum speed capable of the port. Software can modify this value to force a port to train at a lower-than-maximum speed (when in a Beta-only mode), but no lower than the minimum speed.</p>
LPP (Local_plug_present)	1	Rd	This flag is set permanently to 1.
Cable_speed	3	Rd	This variable is set to the maximum speed that the port is capable of in Beta mode. The encoding is the same as for Max_port_speed.
Connection_unreliable	1	Rd/Wr	If this bit is set to 1, then a Beta-mode speed negotiation has failed or synchronization has failed. A write of 1 to this field resets the value to 0.
Beta_mode	1	Rd	Operating in Beta mode. If this bit is 1, the port is operating in Beta mode; it is equal to 0 otherwise (that is, when operating in 1394a-2000 mode, or when disconnected). If Con is 1, RxOK is 1, and Beta_mode is 0, then the port is active and operating in the 1394a-2000 mode.
Port_error	8	Rd/Wr	Incremented whenever the port receives an invalid codeword, unless the value is already 255. Cleared when read (including being read by means of a remote access packet). Intended for use by a single bus-wide diagnostic program.
Sleep_Flag	1	Rd	This bit is set to 1 if the port is in the sleep state. The transition to the sleep state occurs only if the port has been enabled for the sleep mode.
Sleep_enable	1	Rd/Wr	This bit is set to 1 if the port has been enabled for sleep mode. If the SLPEN terminal is sampled high during reset, then this bit is set high for all ports. If sampled low, then it is 0. Software can individually enable or disable sleep mode for a port by writing to this bit. Sleep mode operation is described in the IDB-1394 specification. In PMC mode when no link is present, the sleep state of each port can be monitored on the data lines as described in the Terminal Functions table entry for LCLK_PMC.
Loop_disable	1	Rd	This bit is set to 1 if the port has been placed in the loop-disable state as part of the loop-free build process (the PHYs at either end of the connection are active, but if the connection itself were activated, then a loop would exist). Cleared on bus reset and on disconnection.
In_standby	1	Rd	This bit is set to 1 if the port is in standby power-management state.
Hard_disable	1	Rd/Wr	No effect unless the port is disabled. If this bit is set to 1, the port does not maintain connectivity status on an ac connection when disabled. The values of the Con and RxOK bits are forced to 0. This flag can be used to force renegotiation of the speed of a connection. It can also be used to place the device into a lower-power state because when hard-disabled, a port no longer tones to maintain 1394b ac-connectivity status.

The vendor identification page identifies the vendor/manufacturer and compliance level. The page is selected by writing 1 to the Page_Select field in base register 7. [Table 8](#) shows the configuration of the vendor identification page, and [Table 9](#) shows the corresponding field descriptions.

Table 8. Page 1 (Vendor ID) Register Configuration

Address	BIT POSITION							
	0	1	2	3	4	5	6	7
1000	Compliance							
1001	Reserved							
1010	Vendor_ID0							
1011	Vendor_ID1							
1100	Vendor_ID2							
1101	Product_ID0							
1110	Product_ID1							
1111	Product_ID2							

Table 9. Page 1 (Vendor ID) Register Field Descriptions

FIELD	SIZE	TYPE	DESCRIPTION
Compliance	8	Rd	Compliance level. For the TSB41BA3D, this field is 02h, indicating compliance with the 1394b-2002 specification.
Vendor_ID	24	Rd	Manufacturer's organizationally unique identifier (OUI). For the TSB41BA3D, this field is 08_00_28h (Texas Instruments) (the MSB is at register address 1010b).
Product_ID	24	Rd	Product identifier. For the TSB41BA3D, this field is 83_30_03h (the MSB is at register address 1101b).

The vendor-dependent page provides access to the special control features of the TSB41BA3D, as well as configuration and status information used in manufacturing test and debug. This page is selected by writing 7 to the Page_Select field in base register 7. [Table 10](#) shows the configuration of the vendor-dependent page and [Table 11](#) shows the corresponding field descriptions.

Table 10. Page 7 (Vendor-Dependent) Register Configuration

Address	BIT POSITION							
	0	1	2	3	4	5	6	7
1000	Reserved						Reserved	
1001	Reserved for test							
1010	Reserved for test							
1011	Reserved for test							
1100	Reserved for test							
1101	Reserved for test							
1110	SWR	Reserved for test						
1111	Reserved for test							

Table 11. Page 7 (Vendor-Dependent) Register Field Descriptions

FIELD	SIZE	TYPE	DESCRIPTION
SWR	1	Rd/Wr	Software hard reset. Writing a 1 to this bit forces a hard reset of the PHY (same effect as momentarily asserting the $\overline{\text{RESET}}$ terminal low). This bit is always read as a 0.

Power-Class Programming

The S2_PC0, S1_PC1, and S0_PC2 terminals can be used in some port speed/mode selections to set the default value of the power-class indicated in the pwr field (bits 21–23) of the transmitted self-ID packet. Descriptions of the various power-classes are given in [Table 12](#). The default power-class value is loaded following a hardware reset, but is overridden by any value subsequently loaded into the Pwr_Class field in register 4.

Table 12. Power-Class Descriptions

PC0–PC2	DESCRIPTION
000	Node does not need power and does not repeat power.
001	Node is self-powered and provides a minimum of 15 W to the bus.
010	Node is self-powered and provides a minimum of 30 W to the bus.
011	Node is self-powered and provides a minimum of 45 W to the bus.
100	Node can be powered from the bus and is using up to 3 W; no additional power is needed to enable the link. The node can also provide power to the bus. The amount of bus power that it provides can be found in the configuration ROM.
101	Reserved for future standardization.
110	Node is powered from the bus and uses up to 3 W. An additional 3 W is needed to enable the link.
111	Node is powered from the bus and uses up to 3 W. An additional 7 W is needed to enable the link.

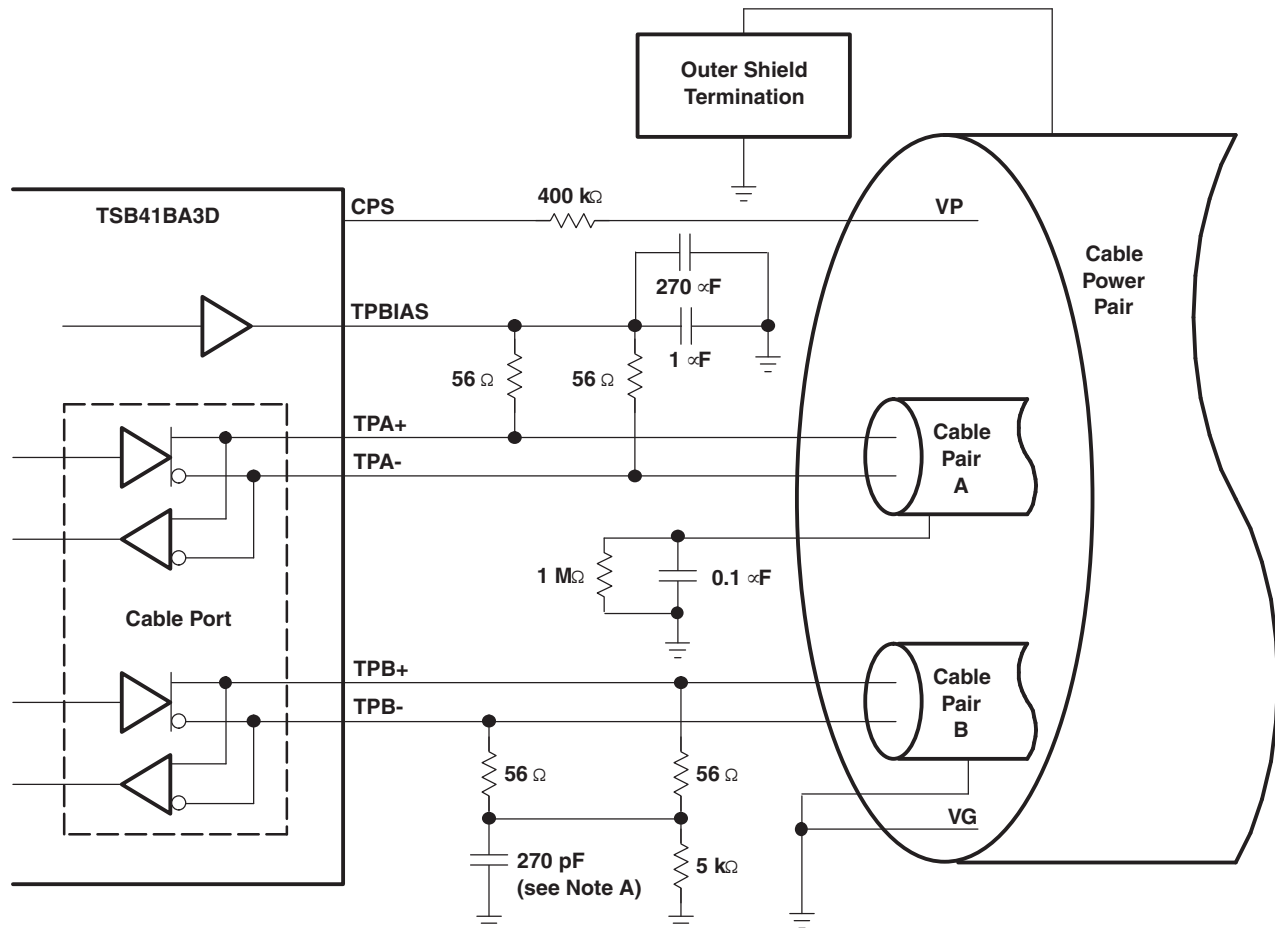

A. The IEEE Std 1394-1995 calls for a 250-pF capacitor, which is a nonstandard component value. A 270-pF capacitor is recommended.

Figure 4. Typical TP Cable Connections

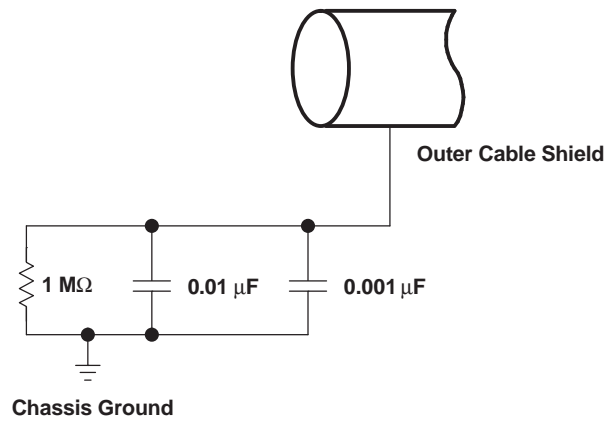

Figure 5. Typical DC-Isolated Outer Shield Termination

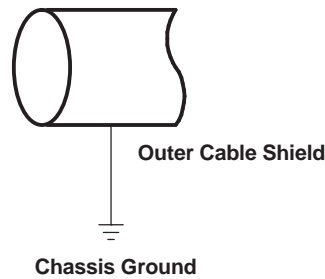

Figure 6. Non-DC-Isolated Outer Shield Termination

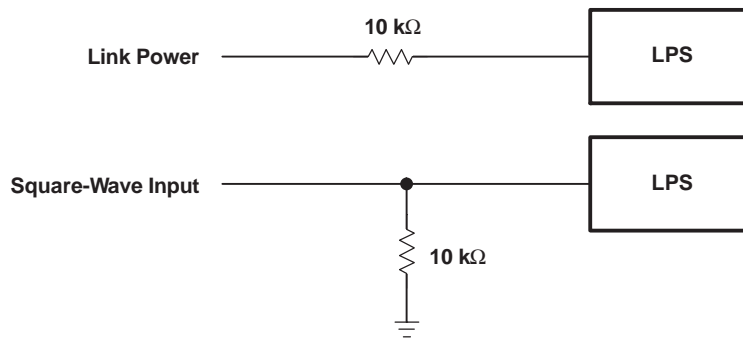

Figure 7. Nonisolated Connection Variations for LPS

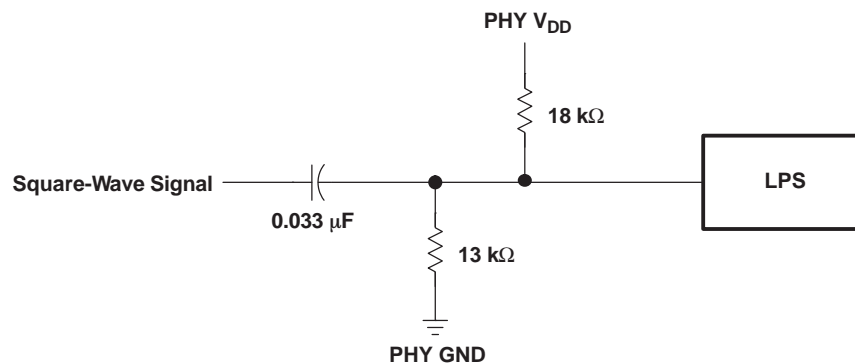

Figure 8. Isolated Circuit Connection for LPS

Designing With PowerPAD™ Devices

The TSB41BA3D is housed in a high-performance, thermally enhanced, 80-terminal PFP PowerPAD package. Use of the PowerPAD package does not require any special considerations except to note that the thermal pad, which is an exposed die pad on the bottom of the device, is a metallic thermal and electrical conductor. Therefore, if not implementing PowerPAD PCB features, the use of solder masks (or other assembly techniques) might be required to prevent any inadvertent shorting by the exposed thermal pad of connection etches or vias under the package. The recommended option, however, is to not run any etches or signal vias under the device, but to have only a grounded thermal land as explained in the following paragraphs. Although the actual size of the exposed die pad can vary, the maximum size required for the keepout area for the 80-terminal PFP PowerPAD package is 10 mm \times 10 mm. The actual thermal pad size for the TSB41BA3D is 6 mm \times 6 mm.

It is required that there be a thermal land, which is an area of solder-tinned-copper, underneath the PowerPAD package. The thermal land varies in size, depending on the PowerPAD package being used, the PCB construction, and the amount of heat that needs to be removed. In addition, the thermal land might or might not contain numerous thermal vias depending on PCB construction.

Other requirements for thermal lands and thermal vias are detailed in the Texas Instruments *PowerPAD™ Thermally Enhanced Package* application report (SLMA002) available via the Texas Instruments Web pages at URL <http://www.ti.com>.

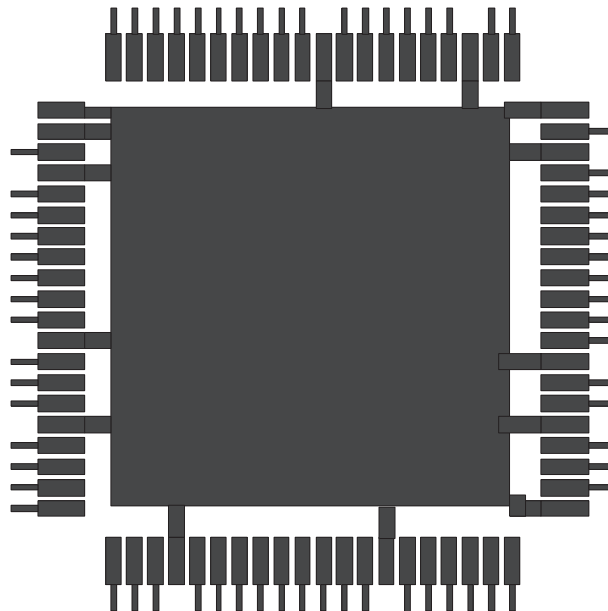

Figure 9. Example of a Thermal Land for the TSB41BA3D PHY

For the TSB41BA3D, this thermal land must be grounded to the low-impedance ground plane of the device. This improves not only thermal performance but also the electrical grounding of the device. It is also recommended that the device ground terminal landing pads be connected directly to the grounded thermal land. The land size ought to be as large as possible without shorting the device signal terminals. The thermal land can be soldered to the exposed thermal pad using standard reflow soldering techniques.

Although the thermal land can be electrically floated and configured to remove heat to an external heat sink, it is recommended that the thermal land be connected to the low-impedance ground plane for the device. More information can be obtained from the Texas Instruments application report *PHY Layout* (SLLA020).

Using the TSB41BA3D With a 1394-1995 or 1394a-2000 Link Layer

The TSB41BA3D implements the PHY-LLC interface specified in the 1394b Supplement. This interface is based on the interface described in Section 17 of IEEE 1394b-2002. When using an LLC that is compliant with the IEEE 1394b-2002 interface, the BMODE input must be tied high.

The TSB41BA3D also functions with an LLC that is compliant with the older 1394 standards. This interface is compatible with both the older Annex J interface specified in the IEEE Std 1394-1995 (with the exception of the Annex J isolation interfacing method) and the PHY-LLC interface specified in 1394a-2000. When using an LLC that is compliant with the IEEE 1394b-2002 interface, the BMODE input must be tied low.

When the BMODE input is tied low, the TSB41BA3D implements the PHY-LLC interface specified in the 1394a-2000 Supplement. This interface is based on the interface described in informative Annex J of IEEE Std 1394-1995, which is the interface used in the oldest Texas Instruments PHY devices. The PHY-LLC interface specified in 1394a-2000 is compatible with the older Annex J. However, the TSB41BA3D does not support the Annex J isolation interfacing method. When implementing the 1394a-2000 interface, certain signals are not used:

- The PINT output (terminal 1) can be left open.
- The LCLK_PMC input (terminal 7) must be tied directly to ground or through a pulldown resistor of ~1 kΩ or less, unless the PMC mode is desired (see LCLK_PMC terminal description).

All other signals are connected to their counterparts on the 1394a link-layer controller. The PCLK output corresponds to the SCLK input signal on most LLCs.

The 1394a-2000 Supplement includes enhancements to the Annex J interface that should be comprehended when using the TSB41BA3D with a 1394-1995 LLC device.

- A new LLC service request was added which allows the LLC to temporarily enable and disable asynchronous arbitration accelerations. If the LLC does not implement this new service request, then the arbitration enhancements must not be enabled (see the EAA bit in PHY register 5).
- The capability to perform multispeed concatenation (the concatenation of packets of differing speeds) was added in order to improve bus efficiency (primarily during isochronous transmission). If the LLC does not support multispeed concatenation, then multispeed concatenation must not be enabled in the PHY (see the EMC bit in PHY register 5).
- In order to accommodate the higher transmission speeds expected in future revisions of the standard, 1394a-2000 extended the speed code in bus requests from 2 bits to 3 bits, increasing the length of the bus request from 7 bits to 8 bits. The new speed codes were carefully selected so that new 1394a-2000 PHY and LLC devices would be compatible, for speeds from S100 to S400, with legacy PHY and LLC devices that use the 2-bit speed codes. The TSB41BA3D correctly interprets both 7-bit bus requests (with 2-bit speed code) and 8-bit bus requests (with 3-bit speed codes). Moreover, if a 7-bit bus request is immediately followed by another request (for example, a register read or write request), then the TSB41BA3D correctly interprets both requests. Although the TSB41BA3D correctly interprets 8-bit bus requests, a request with a speed code exceeding S400 while in 1394a-2000 PHY-link interface mode results in the TSB41BA3D transmitting a null packet (data prefix followed by data end, with no data in the packet).

Power-Up Reset

To ensure proper operation of the TSB41BA3D, the $\overline{\text{RESET}}$ terminal must be asserted low for a minimum of 2 ms from the time that PHY power reaches the minimum required supply voltage and the input clock to the PHY is valid. When using a passive capacitor on the $\overline{\text{RESET}}$ terminal to generate a power-on-reset signal, the minimum reset time is ensured if the value of the capacitor satisfies the following equation (the value must be no smaller than approximately 0.1 μF):

$$C_{\min} = 0.0077 \times T + 0.085 + (\text{external_oscillator_start-up_time} \times 0.05)$$

Where C_{\min} is the minimum capacitance on the $\overline{\text{RESET}}$ terminal in μF, T is the V_{DD} ramp time, 10%–90%, in ms, external_oscillator_start-up_time is the time in ms from application of power to the external oscillator until the oscillator outputs a valid clock. If a crystal is used rather than an oscillator, then the external_oscillator_start-up_time can be set to 0.

For example with a 2-ms power ramp time and a 2-ms oscillator start-up time:

$$C_{\min} = 0.0077 \times 2 + 0.085 + (2 \times 0.05) = 0.2 \mu\text{F}$$

It is appropriate to select the nearest standard value capacitor that exceeds this value, for example 0.22 μF.

Or with a 2-ms power ramp time and a 49.152-MHz fundamental crystal:

$$C_{\min} = 0.0077 \times 2 + 0.085 + (0 \times 0.05) = 0.1 \mu\text{F}$$

Crystal Selection

The TSB41BA3D and other Texas Instruments PHY devices are designed to use an external 49.152-MHz crystal connected between the XI and XO terminals to provide the reference for an internal oscillator circuit. This oscillator in turn drives a PLL circuit that generates the various clocks required for transmission and resynchronization of data at the S100 through S400 media data rates.

A variation of less than ± 100 ppm from nominal for the media data rates is required by IEEE Std 1394. Adjacent PHYs can therefore have a difference of up to 200 ppm from each other in their internal clocks, and PHYs must be able to compensate for this difference over the maximum packet length. Larger clock variations can cause resynchronization overflows or underflows, resulting in corrupted packet data or even PHY lockup.

For the TSB41BA3D, the PCLK output can be used to measure the frequency accuracy and stability of the internal oscillator and PLL from which it is derived. When operating the PHY-LLC interface with a non-1394b LLC, the frequency of the PCLK output must be within ± 100 ppm of the nominal frequency of 49.152 MHz. When operating the PHY-LLC interface with a 1394b LLC, the frequency of the PCLK output must be within ± 100 ppm of the nominal frequency of 98.304 MHz.

The following are some typical specifications for crystals used with the physical layers from Texas Instruments in order to achieve the required frequency accuracy and stability:

- Crystal mode of operation: Fundamental
- Frequency tolerance at 25°C: Total frequency variation for the complete circuit is ± 100 ppm. A crystal with ± 30 ppm frequency tolerance is recommended for adequate margin.
- Frequency stability (over temperature and age): A crystal with ± 30 ppm frequency stability is recommended for adequate margin.

NOTE:

The total frequency variation must be kept below ± 100 ppm from nominal with some allowance for error introduced by board and device variations. Trade-offs between frequency tolerance and stability can be made as long as the total frequency variation is less than ± 100 ppm. For example, the frequency tolerance of the crystal can be specified at 50 ppm, and the temperature tolerance can be specified at 30 ppm to give a total of 80 ppm possible variation due to the oscillator alone. Aging also contributes to the frequency variation.

- Load capacitance: For parallel resonant mode crystal circuits, the frequency of oscillation depends on the load capacitance specified for the crystal. Total load capacitance (C_L) is a function of not only the discrete load capacitors, but also board layout and circuit. It might be necessary to select discrete load capacitors iteratively until the PCLK output is within specification. It is recommended that load capacitors with a maximum of $\pm 5\%$ tolerance be used.

As an example, for the OHCI + 41LV03 evaluation module (EVM), which uses a crystal specified for 12-pF loading, load capacitors (C9 and C10 in [Figure 10](#)) of 16 pF each were appropriate for the layout of that particular board. The load specified for the crystal includes the load capacitors (C9, C10), the loading of the PHY terminals (C_{PHY}), and the loading of the board itself (C_{BD}). The value of C_{PHY} is typically about 1 pF and C_{BD} is typically 0.8 pF per centimeter of board etch; a typical board can have 3 pF to 6 pF or more. The load capacitors C9 and C10 combine as capacitors in series so that the total load capacitance is:

$$C_L = \frac{C9 \times C10}{C9 + C10} + C_{PHY} + C_{BD}$$

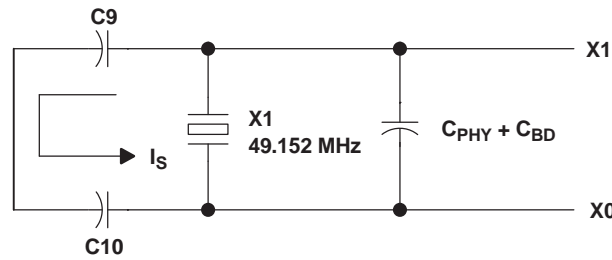

Figure 10. Load Capacitance for the TSB41BA3D PHY

NOTE:

The layout of the crystal portion of the PHY circuit is important for obtaining the correct frequency, minimizing noise introduced into the PHY's phase-locked loop, and minimizing any emissions from the circuit. The crystal and two load capacitors must be considered as a unit during layout. The crystal and load capacitors must be placed as close as possible to one another while minimizing the loop area created by the combination of the three components. Varying the size of the capacitors can help in this. Minimizing the loop area minimizes the effect of the resonant current (I_s) that flows in this resonant circuit. This layout unit (crystal and load capacitors) must then be placed as close as possible to the PHY XI and XO terminals to minimize trace lengths.

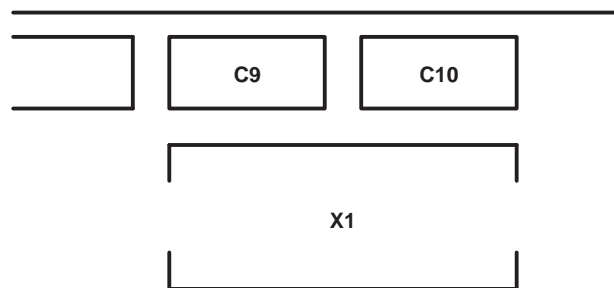

Figure 11. Recommended Crystal and Capacitor Layout

It is strongly recommended that part of the verification process for the design be to measure the frequency of the PCLK output of the PHY. This should be done using a frequency counter with an accuracy of six digits or better. If the PCLK frequency is more than the crystal's tolerance from 49.152 MHz or 98.304 MHz, then the load capacitance of the crystal can be varied to improve frequency accuracy. If the frequency is too high, add more load capacitance; if the frequency is too low, decrease the load capacitance. Typically, changes must be done to both load capacitors (C9 and C10 in Figure 11) at the same time, and both must be of the same value. Additional design details and requirements can be provided by the crystal vendor.

Bus Reset

It is recommended, that whenever the user has a choice, the user should initiate a bus reset by writing to the initiate-short-bus-reset (ISBR) bit (bit 1, PHY register 0101b). Care must be taken to not change the value of any of the other writeable bits in this register when the ISBR bit is written to.

In the TSB41BA3D, the initiate-bus-reset (IBR) bit can be set to 1 in order to initiate a bus reset and initialization sequence; however, it is recommended to use the ISBR bit instead. The IBR bit is located in PHY register 1 along with the root-holdoff bit (RHB) and gap-count register. As required by the 1394b Supplement, this configuration maintains compatibility with older Texas Instruments PHY designs which were based on either the suggested register set defined in Annex J of IEEE Std 1394-1995 or the 1394a-2000 Supplement. Therefore, whenever the IBR bit is written, the RHB and gap-count register are also necessarily written.

It is recommended that the RHB and gap-count register only be updated by PHY configuration packets. The TSB41BA3D is 1394a- and 1394b-compliant, and therefore, both the reception and transmission of PHY configuration packets cause the RHB and gap-count register to be loaded, unlike older IEEE Std 1394-1995-compliant PHYs which decode only received PHY configuration packets.

The gap-count register is set to the maximum value of 63 after two consecutive bus resets without an intervening write to the gap-count register, either by a write to PHY register 1 or by a PHY configuration packet. This mechanism allows a PHY configuration packet to be transmitted and then a bus reset to be initiated so as to verify that all nodes on the bus have updated their RHBs and gap-count register values, without having the gap-count register set back to 63 by the bus reset. The subsequent connection of a new node to the bus, which initiates a bus reset, then causes the gap-count register of each node to be set to 63. Note, however, that if a subsequent bus reset is instead initiated by a write to register 1 to set the IBR bit, then all other nodes on the bus have their gap-count register values set to 63, while this node's gap-count register remains set to the value just loaded by the write to PHY register 1.

Therefore, in order to maintain consistent gap-count registers throughout the bus, the following rules apply to the use of the IBR bit, RHB, and gap-count register in PHY register 1:

- Following the transmission of a PHY configuration packet, a bus reset must be initiated in order to verify that all nodes have correctly updated their RHBs and gap-count register values, and to ensure that a subsequent new connection to the bus causes the gap-count register to be set to 63 on all nodes in the bus. If this bus reset is initiated by setting the IBR bit to 1, then the RHB and gap-count register must also be loaded with the correct values consistent with the just-transmitted PHY configuration packet. In the TSB41BA3D, the RHB and gap-count register have been updated to their correct values on the transmission of the PHY configuration packet and so these values can first be read from register 1 and then rewritten.
- Other than to initiate the bus reset, which must follow the transmission of a PHY configuration packet, whenever the IBR bit is set to 1 in order to initiate a bus reset, the gap-count register value must also be set to 63 so as to be consistent with other nodes on the bus, and the RHB must be maintained with its current value.
- The PHY register 1 must not be written to except to set the IBR bit. The RHB and gap-count register must not be written without also setting the IBR bit to 1.
- To avoid these problems, all bus resets initiated by software must be initiated by writing the ISBR bit (bit 1 PHY register 0101b). Care must be taken to not change the value of any of the other writeable bits in this register when the ISBR bit is written to. Also, the only means to change the gap count of any node must be by means of the PHY configuration packet, which changes all nodes to the same gap count.

PRINCIPLES OF OPERATION (1394a-2000 INTERFACE)

The TSB41BA3D is designed to operate with an LLC such as the Texas Instruments TSB12LV21B, TSB12LV26, TSB12LV32, TSB42AA4, or TSB12LV01B when the BMODE terminal is tied low. Details of operation for the Texas Instruments LLC devices are found in the respective LLC data sheets. The following paragraphs describe the operation of the PHY-LLC interface. This interface is formally defined in IEEE 1394a-2000, Section 5A.

The interface to the LLC consists of the PCLK, CTL0–CTL1, D0–D7, LREQ, LPS, and S5_LKON terminals on the TSB41BA3D, as shown in [Figure 12](#).

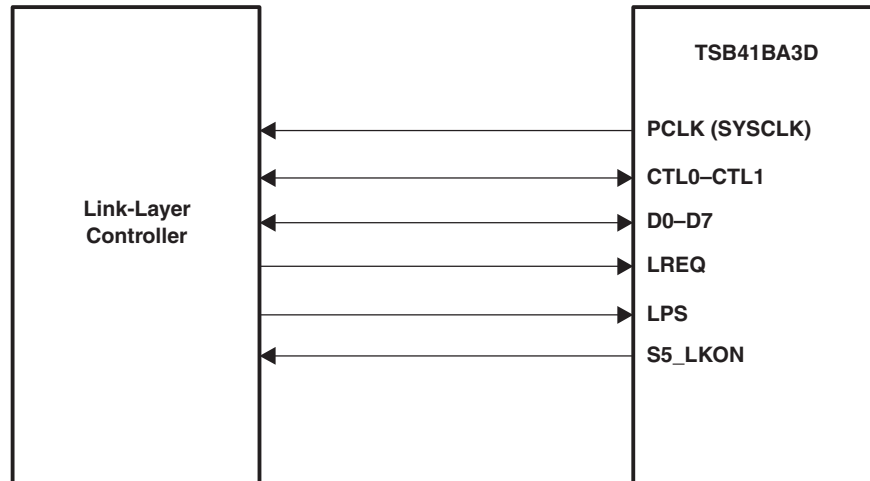

Figure 12. PHY-LLC Interface

The PCLK terminal provides a 49.152-MHz interface system clock. All control and data signals are synchronized to and sampled on the rising edge of PCLK. This terminal serves the same function as the SYSCLK terminal of 1394a-2000-compliant PHY devices.

The CTL0 and CTL1 terminals form a bidirectional control bus, which controls the flow of information and data between the TSB41BA3D and LLC.

The D0–D7 terminals form a bidirectional data bus, which transfers status information, control information, or packet data between the devices. The TSB41BA3D supports S100, S200, and S400 data transfers over the D0–D7 data bus. In S100 operation, only the D0 and D1 terminals are used; in S200 operation, only the D0–D3 terminals are used; and in S400 operation, all D0–D7 terminals are used for data transfer. When the TSB41BA3D is in control of the D0–D7 bus, unused Dn terminals are driven low during S100 and S200 operations. When the LLC is in control of the D0–D7 bus, unused Dn terminals are ignored by the TSB41BA3D.

The LREQ terminal is controlled by the LLC to send serial service requests to the PHY in order to request access to the serial bus for packet transmission, read or write PHY registers, or control arbitration acceleration.

The LPS and S5_LKON terminals are used for power management of the PHY and LLC. The LPS terminal indicates the power status of the LLC and can be used to reset the PHY-LLC interface or to disable PCLK. The S5_LKON terminal sends a wake-up notification to the LLC or external circuitry and indicates an interrupt to the LLC when either LPS is inactive or the PHY register L bit is 0.

The TSB41BA3D normally controls the CTL0–CTL1 and D0–D7 bidirectional buses. The LLC is allowed to drive these buses only after the LLC has been granted permission to do so by the PHY.

Four operations can occur on the PHY-LLC interface: link service request, status transfer, data transmit, and data receive. The LLC issues a service request to read or write a PHY register, to request the PHY to gain control of the serial bus in order to transmit a packet, or to control arbitration acceleration.

The PHY can initiate a status transfer either autonomously or in response to a register read request from the LLC.

The PHY initiates a receive operation whenever a packet is received from the serial bus.

The PHY initiates a transmit operation after winning control of the serial bus following a bus request by the LLC. The transmit operation is initiated when the PHY grants control of the interface to the LLC.

Table 13 and Table 14 show the encoding of the CTL0–CTL1 bus.

Table 13. CTL Encoding When PHY Has Control of the Bus

CTL0	CTL1	NAME	DESCRIPTION
0	0	Idle	No activity (this is the default mode)
0	1	Status	Status information is being sent from the PHY to the LLC.
1	0	Receive	An incoming packet is being sent from the PHY to the LLC.
1	1	Grant	The LLC has been given control of the bus to send an outgoing packet.

Table 14. CTL Encoding When LLC Has Control of the Bus

CTL0	CTL1	NAME	DESCRIPTION
0	0	Idle	The LLC releases the bus (transmission has been completed).
0	1	Hold	The LLC is holding the bus while data is being prepared for transmission or indicating that another packet is to be transmitted (concatenated) without arbitrating.
1	0	Transmit	An outgoing packet is being sent from the LLC to the PHY.
1	1	Reserved	None

LLC Service Request

To request access to the bus, to read or write a PHY register, or to control arbitration acceleration, the LLC sends a serial bit stream on the LREQ terminal as shown in Figure 13.



Each cell represents one clock sample period, and n is the number of bits in the request stream.

Figure 13. LREQ Request Stream

The length of the stream varies depending on the type of request as shown in Table 15.

Table 15. Request Stream Bit Length

REQUEST TYPE	NUMBER OF BITS
Bus request	7 or 8
Read register request	9
Write register request	17
Acceleration control request	6

Regardless of the type of request, a start bit of 1 is required at the beginning of the stream, and a stop bit of 0 is required at the end of the stream. The second through fourth bits of the request stream indicate the type of the request. In the following descriptions, bit 0 is the most significant and is transmitted first in the request bit stream. The LREQ terminal is normally low.

Table 16 shows the encoding for the request type.

Table 16. Request Type Encoding

LR1–LR3	NAME	DESCRIPTION
000	ImmReq	Immediate bus request. On detection of idle, the PHY takes control of the bus immediately without arbitration.
001	IsoReq	Isochronous bus request. On detection of idle, the PHY arbitrates for the bus without waiting for a subaction gap.
010	PriReq	Priority bus request. The PHY arbitrates for the bus after a subaction gap, ignores the fair protocol.
011	FairReq	Fair bus request. The PHY arbitrates for the bus after a subaction gap, follows the fair protocol.
100	RdReg	The PHY returns the specified register contents through a status transfer.
101	WrReg	Write to the specified register
110	AccelCtl	Enable or disable asynchronous arbitration acceleration
111	Reserved	Reserved

For a bus request, the length of the LREQ bit stream is 7 or 8 bits as shown in Table 17.

Table 17. Bus Request

BIT(s)	NAME	DESCRIPTION
0	Start bit	Indicates the beginning of the transfer (always 1)
1–3	Request type	Indicates the type of bus request. See Table 16.
4–6	Request speed	Indicates the speed at which the PHY sends the data for this request. See Table 18 for the encoding of this field.
7	Stop bit	Indicates the end of the transfer (always 0). If bit 6 is 0, then this bit can be omitted.

Table 18 shows the 3-bit request speed field used in bus requests.

Table 18. Bus Request Speed Encoding

LR4–LR6	DATA RATE
000	S100
010	S200
100	S400
All Others	Invalid

NOTE:

The TSB41BA3D accepts a bus request with an invalid speed code and processes the bus request normally. However, during packet transmission for such a request, the TSB41BA3D ignores any data presented by the LLC and transmits a null packet.

For a read register request, the length of the LREQ bit stream is 9 bits as shown in Table 19.

Table 19. Read Register Request

BIT(s)	NAME	DESCRIPTION
0	Start bit	Indicates the beginning of the transfer (always 1)
1–3	Request type	A 100 indicates this is a read register request.
4–7	Address	Identifies the address of the PHY register to be read
8	Stop bit	Indicates the end of the transfer (always 0)

For a write register request, the length of the LREQ bit stream is 17 bits as shown in Table 20.

Table 20. Write Register Request

BIT(s)	NAME	DESCRIPTION
0	Start bit	Indicates the beginning of the transfer (always 1)
1–3	Request type	A 101 indicates this is a write register request.
4–7	Address	Identifies the address of the PHY register to be written to
8–15	Data	Gives the data that is to be written to the specified register address
16	Stop bit	Indicates the end of the transfer (always 0)

For an acceleration control request, the length of the LREQ data stream is 6 bits as shown in [Table 21](#).

Table 21. Acceleration Control Request

BIT(s)	NAME	DESCRIPTION
0	Start bit	Indicates the beginning of the transfer (always 1)
1–3	Request type	A 110 indicates this is an acceleration control request.
4	Control	Asynchronous period arbitration acceleration is enabled if 1 and disabled if 0
5	Stop bit	Indicates the end of the transfer (always 0)

For fair or priority access, the LLC sends the bus request (FairReq or PriReq) at least one clock after the PHY-LLC interface becomes idle. If the CTL terminals are asserted to the receive state (10b) by the PHY, then any pending fair or priority request is lost (cleared). Additionally, the PHY ignores any fair or priority requests if the receive state is asserted while the LLC is sending the request. The LLC can then reissue the request one clock after the next interface idle.

The cycle master node uses a priority bus request (PriReq) to send a cycle start message. After receiving or transmitting a cycle start message, the LLC can issue an isochronous bus request (IsoReq). The PHY clears an isochronous request only when the serial bus has been won.

To send an acknowledge packet, the LLC must issue an immediate bus request (ImmReq) during the reception of the packet addressed to it. This is required in order to minimize the idle gap between the end of the received packet and the start of the transmitted acknowledge packet. As soon as the receive packet ends, the PHY immediately grants control of the bus to the LLC. The LLC sends an acknowledgment to the sender unless the header CRC of the received packet is corrupted. In this case, the LLC does not transmit an acknowledge, but instead cancels the transmit operation and releases the interface immediately; the LLC must not use this grant to send another type of packet. After the interface is released, the LLC can proceed with another request.

The LLC can make only one bus request at a time. Once the LLC issues any request for bus access (ImmReq, IsoReq, FairReq, or PriReq), it cannot issue another bus request until the PHY indicates that the bus request was lost (bus arbitration lost and another packet received), or won (bus arbitration won and the LLC granted control). The PHY ignores new bus requests while a previous bus request is pending. All bus requests are cleared on a bus reset.

For write register requests, the PHY loads the specified data into the addressed register as soon as the request transfer is complete. For read register requests, the PHY returns the contents of the addressed register to the LLC at the next opportunity through a status transfer. If a received packet interrupts the status transfer, then the PHY continues to attempt the transfer of the requested register until it is successful. A write or read register request can be made at any time, including while a bus request is pending. Once a read register request is made, the PHY ignores further read register requests until the register contents are successfully transferred to the LLC. A bus reset does not clear a pending read register request.

The TSB41BA3D includes several arbitration acceleration enhancements, which allow the PHY to improve bus performance and throughput by reducing the number and length of interpacket gaps. These enhancements include autonomous (fly-by) isochronous packet concatenation, autonomous fair and priority packet concatenation onto acknowledge packets, and accelerated fair and priority request arbitration following acknowledge packets. The enhancements are enabled when the EAA bit in PHY register 5 is set.

The arbitration acceleration enhancements can interfere with the ability of the cycle master node to transmit the cycle start message under certain circumstances. The acceleration control request is therefore provided to allow the LLC temporarily to enable or disable the arbitration acceleration enhancements of the TSB41BA3D during the asynchronous period. The LLC typically disables the enhancements when its internal cycle counter rolls over, indicating that a cycle-start message is imminent, and then re-enables the enhancements when it receives a cycle-start message. The acceleration control request can be made at any time and is immediately serviced by the PHY. Additionally, a bus reset or isochronous bus request causes the enhancements to be re-enabled, if the EAA bit is set.

Status Transfer

A status transfer is initiated by the PHY when there is status information to be transferred to the LLC. The PHY waits until the interface is idle before starting the transfer. The transfer is initiated by the PHY asserting status(01b) on the CTL terminals, along with the first two bits of status information on the D[0:1] terminals. The PHY maintains CTL = Status for the duration of the status transfer. The PHY might prematurely end a status transfer by asserting something other than *status* on the CTL terminals. This occurs if a packet is received before the status transfer completes. The PHY continues to attempt to complete the transfer until all status information has been successfully transmitted. At least one idle cycle occurs between consecutive status transfers.

The PHY normally sends just the first 4 bits of status to the LLC. These bits are status flags that are needed by the LLC state machines. The PHY sends an entire 16-bit status packet to the LLC after a read register request, or when the PHY has pertinent information to send to the LLC or transaction layers. The only defined condition where the PHY automatically sends a register to the LLC is after self-ID, where the PHY sends the physical-ID register that contains the new node address. All status transfers are either 4 or 16 bits unless interrupted by a received packet. The status flags are considered to have been successfully transmitted to the LLC immediately on being sent, even if a received packet subsequently interrupts the status transfer. Register contents are considered to have been successfully transmitted only when all 8 bits of the register have been sent. A status transfer is retried after being interrupted only if any status flags remain to be sent, or if a register transfer has not yet completed.

Table 22 shows the definition of the bits in the status transfer, and Figure 14 shows the timing.

Table 22. Status Bits

BIT(s)	NAME	DESCRIPTION
0	Arbitration reset gap	Indicates that the PHY has detected that the bus has been idle for an arbitration reset gap time (as defined in the IEEE 1394a-2000 standard). This bit is used by the LLC in the busy/retry state machine.
1	Subaction gap	Indicates that the PHY has detected that the bus has been idle for a subaction gap time (as defined in the IEEE 1394a-2000 standard). This bit is used by the LLC to detect the completion of an isochronous cycle.
2	Bus reset	Indicates that the PHY has entered the bus reset state
3	Interrupt	Indicates that a PHY interrupt event has occurred. An interrupt event might be a configuration time-out, a cable-power voltage falling too low, a state time-out, or a port status change.
4–7	Address	This field holds the address of the PHY register whose contents are being transferred to the LLC.
8–15	Data	This field holds the register contents.

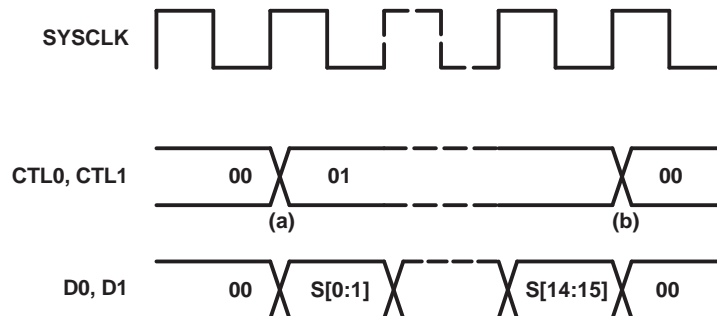

Figure 14. Status Transfer Timing

The sequence of events for a status transfer is as follows:

- a. Status transfer initiated. The PHY indicates a status transfer by asserting status on the CTL lines along with the status data on the D0 and D1 lines (only 2 bits of status are transferred per cycle). Normally (unless interrupted by a receive operation), a status transfer is either 2 or 8 cycles long. A 2-cycle (4-bit) transfer occurs when only status information is to be sent. An 8-cycle (16-bit) transfer occurs when register data is to be sent in addition to any status information.
- b. Status transfer terminated. The PHY normally terminates a status transfer by asserting idle on the CTL lines. The PHY can also interrupt a status transfer at any cycle by asserting receive on the CTL lines to begin a receive operation. The PHY asserts at least one idle cycle between consecutive status transfers.

Receive

Whenever the PHY detects the data-prefix state on the serial bus, it initiates a receive operation by asserting receive on the CTL terminals and a logic 1 on each of the D bus terminals (data-on indication). The PHY indicates the start of a packet by placing the speed code (encoded as shown in [Table 23](#)) on the D terminals, followed by packet data. The PHY holds the CTL terminals in the receive state until the last symbol of the packet has been transferred. The PHY indicates the end of packet data by asserting idle on the CTL terminals. All received packets are transferred to the LLC. Note that the speed code is part of the PHY-LLC protocol and is not included in the calculation of CRC or any other data protection mechanisms.

It is possible for the PHY to receive a null packet, which consists of the data-prefix state on the serial bus followed by the data-end state, without any packet data. A null packet is transmitted whenever the packet speed exceeds the capability of the receiving PHY, or whenever the LLC immediately releases the bus without transmitting any data. In this case, the PHY asserts receive on the CTL terminals with the data-on indication (all 1s) on the D bus terminals, followed by Idle on the CTL terminals, without any speed code or data being transferred. In all cases, in normal operation, the TSB41BA3D sends at least one data-on indication before sending the speed code or terminating the receive operation.

The TSB41BA3D also transfers its own self-ID packet, transmitted during the self-ID phase of bus initialization, to the LLC. This packet is transferred to the LLC just as any other received self-ID packet.

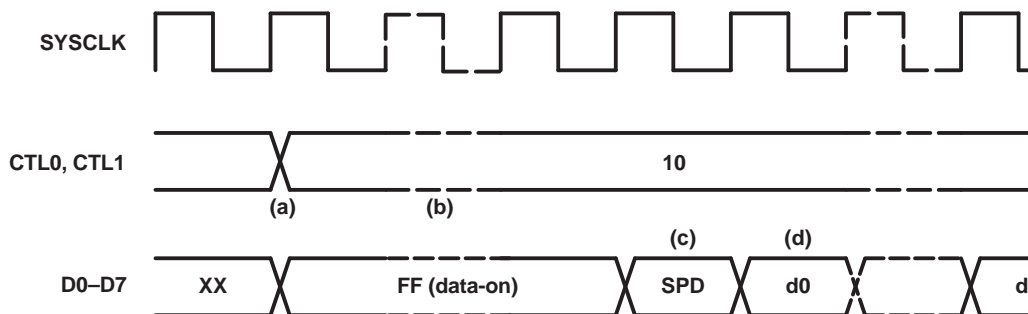

A. SPD = Speed code, see [Table 23](#). d0–dn = Packet data

Figure 15. Normal Packet Reception Timing

The sequence of events for a normal packet reception is as follows:

- a. Receive operation initiated. The PHY indicates a receive operation by asserting receive on the CTL lines. Normally, the interface is idle when receive is asserted. However, the receive operation can interrupt a status transfer operation that is in progress so that the CTL lines can change from status to receive without an intervening idle.
- b. Data-on indication. The PHY can assert the data-on indication code on the D lines for one or more cycles preceding the speed code.
- c. Speed code. The PHY indicates the speed of the received packet by asserting a speed code on the D lines for one cycle immediately preceding packet data. The link decodes the speed code on the first receive cycle for which the D lines are not the data-on code. If the speed code is invalid or indicates a speed higher than which the link is capable of handling, then the link must ignore the subsequent data.
- d. Receive data. Following the data-on indication (if any) and the speed code, the PHY asserts packet data on the D lines with receive on the CTL lines for the remainder of the receive operation.
- e. Receive operation terminated. The PHY terminates the receive operation by asserting idle on the CTL lines.

The PHY asserts at least one idle cycle following a receive operation.

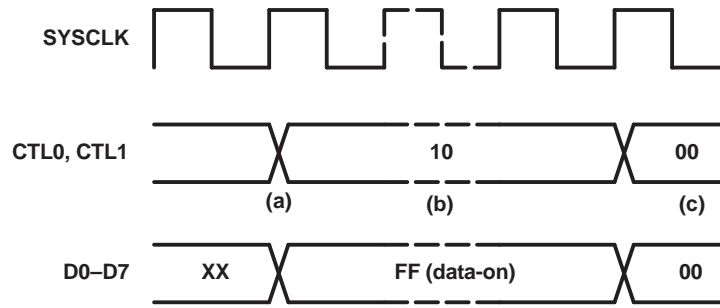

Figure 16. Null Packet Reception Timing

The sequence of events for a null packet reception is as follows:

- a. Receive operation initiated. The PHY indicates a receive operation by asserting receive on the CTL lines. Normally, the interface is idle when receive is asserted. However, the receive operation can interrupt a status transfer operation that is in progress so that the CTL lines can change from status to receive without an intervening idle.
- b. Data-on indication. The PHY asserts the data-on indication code on the D lines for one or more cycles.
- c. Receive operation terminated. The PHY terminates the receive operation by asserting idle on the CTL lines. The PHY asserts at least one idle cycle following a receive operation.

Table 23. Receive Speed Codes

D0–D7 ⁽¹⁾	DATA RATE
00XX XXXX	S100
0100 XXXX	S200
0101 0000	S400
11YY YYYY	data-on indication

(1) X = Output as 0 by PHY, ignored by LLC.
 Y = Output as 1 by PHY, ignored by LLC.

Transmit

When the LLC issues a bus request through the LREQ terminal, the PHY arbitrates to gain control of the bus. If the PHY wins arbitration for the serial bus, then the PHY-LLC interface bus is granted to the LLC by asserting the grant state (11b) on the CTL terminals for one PCLK cycle, followed by idle for one clock cycle. The LLC then takes control of the bus by asserting either idle (00b), hold (01b) or transmit (10b) on the CTL terminals. Unless the LLC is immediately releasing the interface, the LLC can assert the idle state for at most one clock before it must assert either hold or transmit on the CTL terminals. The hold state is used by the LLC to retain control of the bus while it prepares data for transmission. The LLC can assert hold for zero or more clock cycles (that is, the LLC need not assert hold before transmit). The PHY asserts data-prefix on the serial bus during this time.

When the LLC is ready to send data, the LLC asserts transmit on the CTL terminals as well as sending the first bits of packet data on the D lines. The transmit state is held on the CTL terminals until the last bits of data have been sent. The LLC then asserts either hold or idle on the CTL terminals for one clock cycle and then asserts idle for one additional cycle before releasing the interface bus and putting the CTL and D terminals in a high-impedance state. The PHY then regains control of the interface bus.

The hold state asserted at the end-of-packet transmission indicates to the PHY that the LLC requests to send another packet (concatenated packet) without releasing the serial bus. The PHY responds to this concatenation request by waiting the required minimum packet separation time and then asserting grant as before. This function can be used to send a unified response after sending an acknowledge or to send consecutive isochronous packets during a single isochronous period. Unless multispeed concatenation is enabled, all packets transmitted during a single bus ownership must be of the same speed (because the speed of the packet is set before the first packet). If multispeed concatenation is enabled (when the EMSC bit of PHY register 5 is set), then the LLC must specify the speed code of the next concatenated packet on the D terminals when it asserts hold on the CTL terminals at the end of a packet. The encoding for this speed code is the same as the speed code that precedes received packet data as given in [Table 23](#).

After sending the last packet for the current bus ownership, the LLC releases the bus by asserting idle on the CTL terminals for two clock cycles. The PHY begins asserting idle on the CTL terminals one clock after sampling idle from the link. Note that whenever the D and CTL terminals change direction between the PHY and the LLC, an extra clock period is allowed so that both sides of the interface can operate on registered versions of the interface signals.

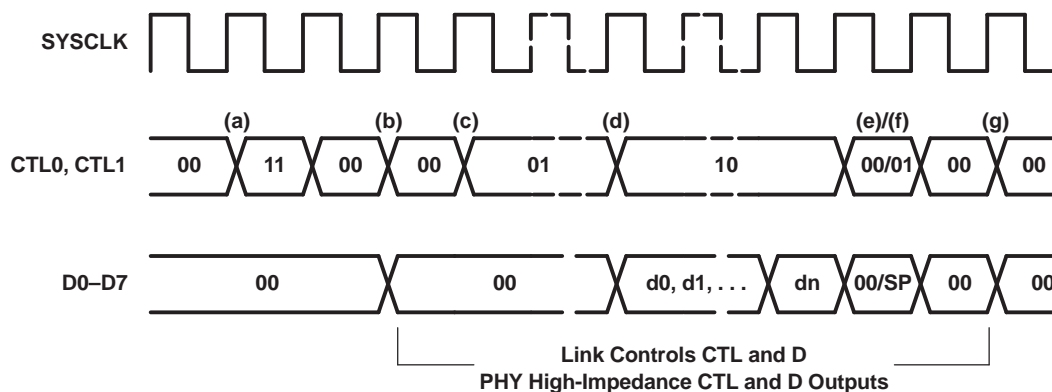

A. SPD = Speed code, see [Table 23](#). d0–dn = Packet data

Figure 17. Normal Packet Transmission Timing

The sequence of events for a normal packet transmission is as follows:

- a. Transmit operation initiated. The PHY asserts grant on the CTL lines followed by idle to hand over control of the interface to the link so that the link can transmit a packet. The PHY releases control of the interface (that is, it places its CTL and D outputs in a high-impedance state) following the idle cycle.
- b. Optional idle cycle. The link can assert at most one idle cycle preceding assertion of either hold or transmit. This idle cycle is optional; the link is not required to assert idle preceding either hold or transmit.
- c. Optional hold cycles. The link can assert hold for up to 47 cycles preceding assertion of transmit. These hold cycle(s) are optional; the link is not required to assert hold preceding transmit.
- d. Transmit data. When data is ready to be transmitted, the link asserts transmit on the CTL lines along with the data on the D lines.
- e. Transmit operation terminated. The transmit operation is terminated by the link asserting hold or idle on the CTL lines. The link asserts hold to indicate that the PHY is to retain control of the serial bus in order to transmit a concatenated packet. The link asserts idle to indicate that packet transmission is complete and the PHY can release the serial bus. The link then asserts idle for one more cycle following this hold or idle cycle before releasing the interface and returning control to the PHY.
- f. Concatenated packet speed code. If multispeed concatenation is enabled in the PHY, then the link asserts a speed code on the D lines when it asserts hold to terminate packet transmission. This speed code indicates the transmission speed for the concatenated packet that is to follow. The encoding for this concatenated

packet speed code is the same as the encoding for the received packet speed code (see Table 23). The link cannot concatenate an S100 packet onto any higher-speed packet.

- g. After regaining control of the interface, the PHY asserts at least one idle cycle before any subsequent status transfer, receive operation, or transmit operation.

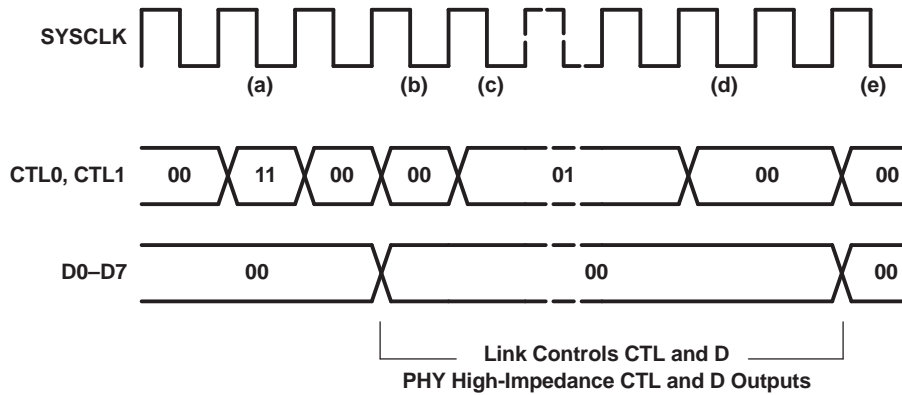

Figure 18. Cancelled/Null Packet Transmission

The sequence of events for a cancelled/null packet transmission is as follows:

- a. Transmit operation initiated. PHY asserts grant on the CTL lines followed by idle to hand over control of the interface to the link.
- b. Optional idle cycle. The link can assert at most one idle cycle preceding assertion of hold. This idle cycle is optional; the link is not required to assert idle preceding hold.
- c. Optional hold cycles. The link can assert hold for up to 47 cycles preceding assertion of idle. These hold cycle(s) are optional; the link is not required to assert hold preceding idle.
- d. Null transmit termination. The null transmit operation is terminated by the link asserting two cycles of idle on the CTL lines and then releasing the interface and returning control to the PHY. Note that the link can assert idle for a total of three consecutive cycles if it asserts the optional first idle cycle but does not assert hold. It is recommended that the link assert three cycles of idle to cancel a packet transmission if no hold cycles are asserted. This ensures that either the link or PHY controls the interface in all cycles.
- e. After regaining control of the interface, the PHY asserts at least one idle cycle before any subsequent status transfer, receive operation, or transmit operation.

Interface Reset and Disable

The LLC controls the state of the PHY-LLC interface using the LPS signal. The interface can be placed into a reset state, a disabled state, or be made to initialize and then return to normal operation. When the interface is not operational (whether reset, disabled, or in the process of initialization), the PHY cancels any outstanding bus request or register read request, and ignores any requests made via the LREQ line. Additionally, any status information generated by the PHY is not queued and does not cause a status transfer on restoration of the interface to normal operation.

The LPS signal can be either a level signal or a pulsed signal, depending on whether the PHY-LLC interface is a direct connection or is made across an isolation barrier. When an isolation barrier exists between the PHY and LLC, the LPS signal must be pulsed. In a direct connection, the LPS signal can be either a pulsed or a level signal. Timing parameters for the LPS signal are given in Table 24.

Table 24. LPS Timing Parameters

SYMBOL	DESCRIPTION	MIN	MAX	UNIT
t_{LPSL}	LPS low time (when pulsed) ⁽¹⁾	0.09	2.6	μ s
t_{LPSH}	LPS high time (when pulsed) ⁽¹⁾	0.021	2.6	μ s
t_{LPS_DUTY}	LPS duty cycle (when pulsed) ⁽²⁾	20%	60%	
t_{LPS_RESET}	Time for PHY to recognize LPS deasserted and reset the interface	2.6	2.68	μ s
$t_{LPS_DISABLE}$	Time for PHY to recognize LPS deasserted and disable the interface	26.03	26.11	μ s
$t_{RESTORE}$	Time to permit optional isolation circuits to restore during an interface reset	15	23 ⁽³⁾	μ s
$t_{CLK_ACTIVATE}$	Time for PCLK to be activated from reassertion of LPS	PHY not in low-power state	60	ns
		PHY in low-power state	5.3	7.3

- (1) The specified t_{LPSL} and t_{LPSH} times are worst-case values appropriate for operation with the TSB41BA3D. These values are broader than those specified for the same parameters in the 1394a-2000 Supplement (that is, an implementation of LPS that meets the requirements of 1394a-2000 operates correctly with the TSB41BA3D).
- (2) A pulsed LPS signal must have a duty cycle (ratio of t_{LPSH} to cycle period) in the specified range to ensure proper operation when using an isolation barrier on the LPS signal (for example, as shown in Figure 8).
- (3) The maximum value for $t_{RESTORE}$ does not apply when the PHY-LLC interface is disabled, in which case an indefinite time can elapse before LPS is reasserted. Otherwise, in order to reset but not disable the interface, it is necessary that the LLC ensure that LPS is deasserted for less than $t_{LPS_DISABLE}$.

The LLC requests that the interface be reset by deasserting the LPS signal and terminating all bus and request activity. When the PHY observes that LPS has been deasserted for t_{LPS_RESET} , it resets the interface. When the interface is in the reset state, the PHY sets its CTL and D outputs in the logic 0 state and ignores any activity on the LREQ signal. Figure 19 shows the timing for interface reset.

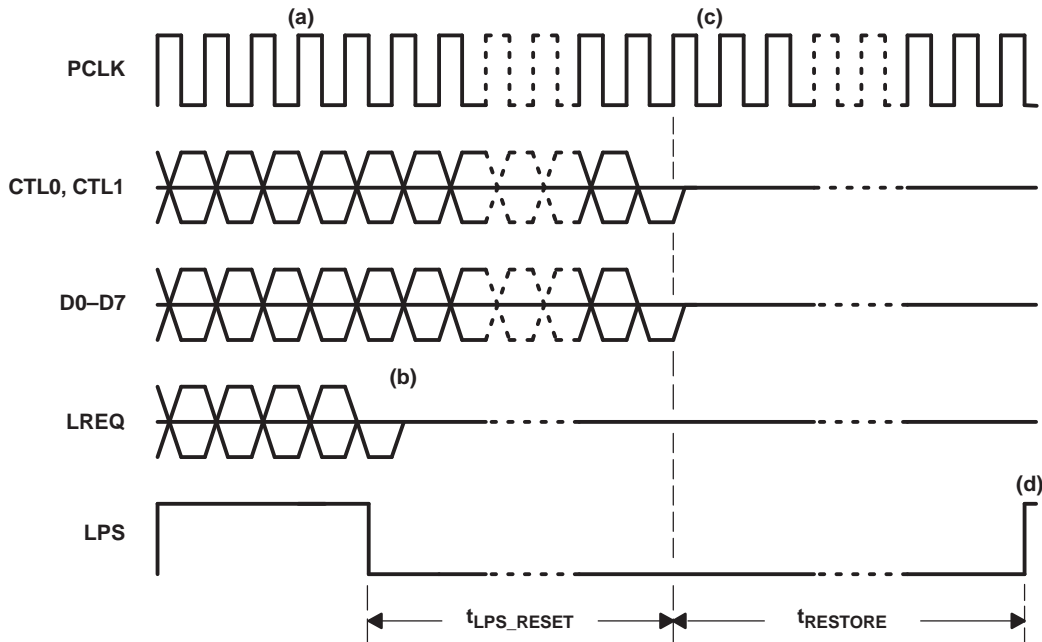

Figure 19. Interface Reset

The sequence of events for resetting the PHY-LLC interface is as follows:

- a. Normal operation. Interface is operating normally, with LPS asserted, PCLK active, status and packet data reception and transmission via the CTL and D lines, and request activity via the LREQ line. In Figure 19, the LPS signal is shown as a nonpulsed level signal. However, it is permissible to use a pulsed signal for LPS in a direct connection between the PHY and LLC; a pulsed signal is required when using an isolation barrier.
- b. LPS deasserted. The LLC deasserts the LPS signal and, within 1 μ s, terminates any request or interface bus activity, places its CTL and D outputs into the high-impedance state, and drives its LREQ output low.
- c. Interface reset. After t_{LPS_RESET} time, the PHY determines that LPS is inactive, terminates any interface bus activity, and drives its CTL and D outputs low. The PHY-LLC interface is now in the reset state.

d. Interface restored. After the minimum $t_{RESTORE}$ time, the LLC can again assert LPS active. When LPS is asserted, the interface is initialized as described in the following paragraph.

If the LLC continues to keep the LPS signal deasserted, it then requests that the interface be disabled. The PHY disables the interface when it observes that LPS has been deasserted for $t_{LPS_DISABLE}$. When the interface is disabled, the PHY sets its CTL and D outputs as previously stated for interface reset, but also stops PCLK activity. The interface is also placed into the disabled condition on a hardware reset of the PHY. Figure 20 shows the timing for the interface disable.

When the interface is disabled, the PHY enters a low-power state if none of its ports are active.

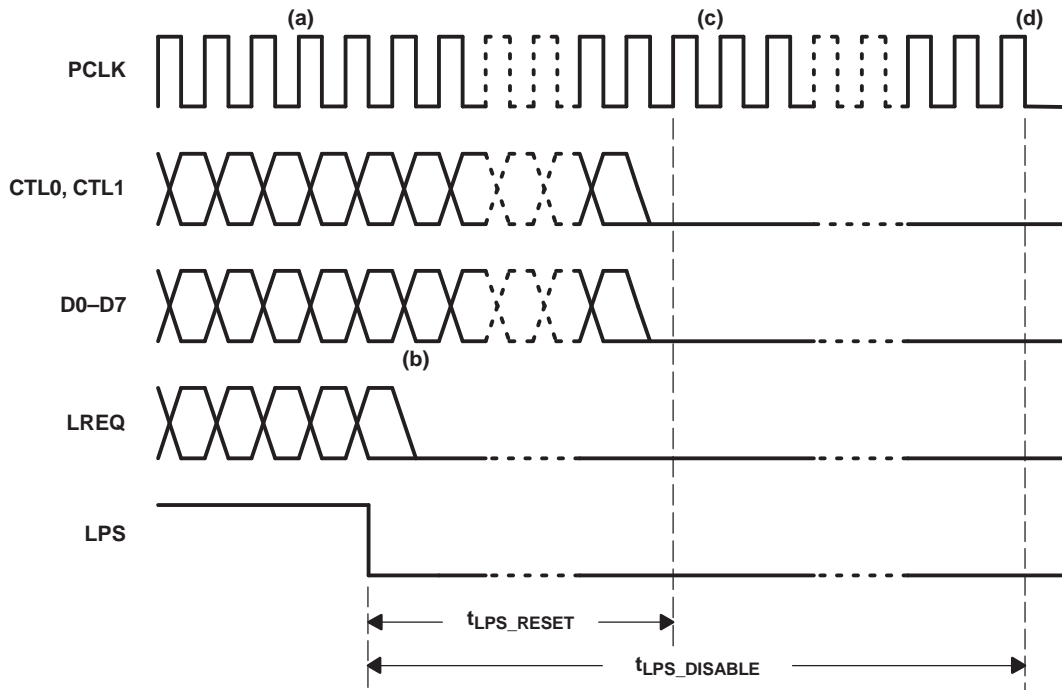

Figure 20. Interface Disable

The sequence of events for disabling the PHY-LLC is as follows:

- a. Normal operation. Interface is operating normally, with LPS active, PCLK active, status and packet data reception and transmission via the CTL and D lines, and request activity via the LREQ line.
- b. LPS deasserted. The LLC deasserts the LPS signal and, within 1 μ s, terminates any request or interface bus activity, places its CTL and D outputs into a high-impedance state, and drives its LREQ output low.
- c. Interface reset. After t_{LPS_RESET} time, the PHY determines that LPS is inactive, terminates any interface bus activity, and drives its CTL and D outputs low. The PHY-LLC interface is now in the reset state.
- d. Interface disabled. If the LPS signal remains inactive for $t_{LPS_DISABLE}$ time, then the PHY terminates PCLK activity by driving the PCLK output low. The PHY-LLC interface is now in the disabled state.

After the interface has been reset, or reset and then disabled, the interface is initialized and restored to normal operation when LPS is reasserted by the LLC. Figure 21 shows the timing for interface initialization.

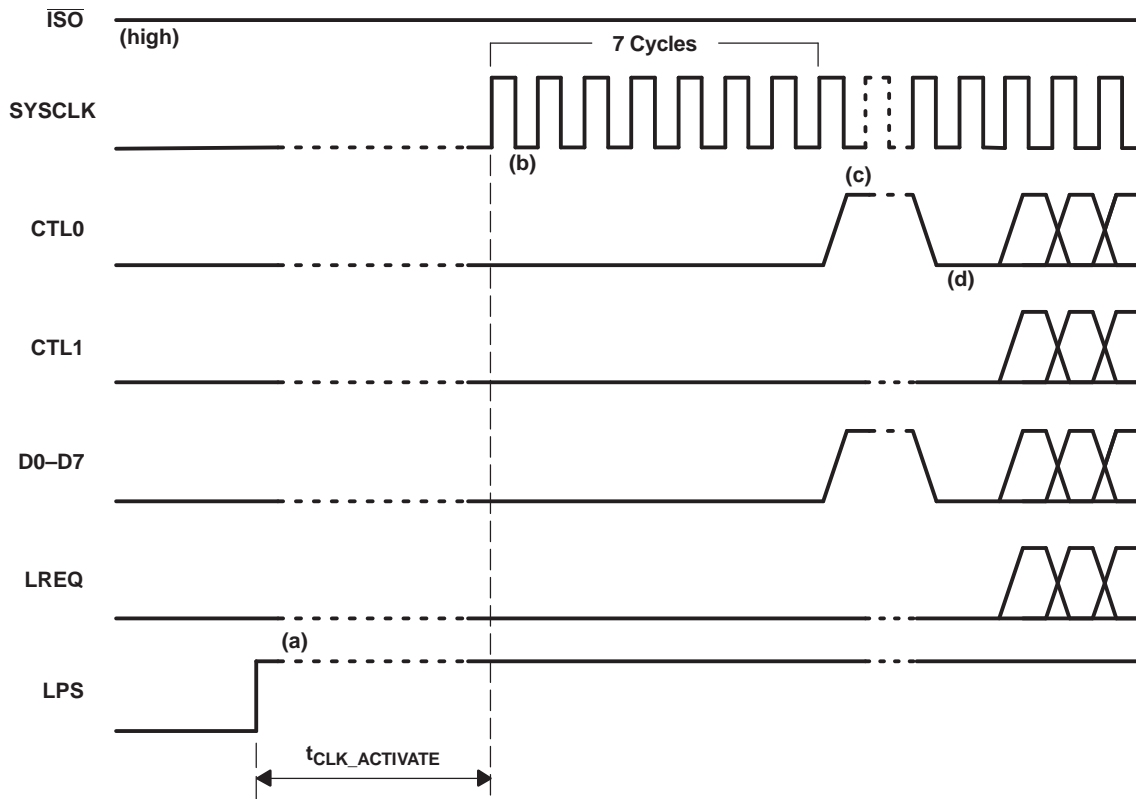

Figure 21. Interface Initialization

The sequence of events for initialization of the PHY-LLC is as follows:

- LPS reasserted. After the interface has been in the reset or disabled state for at least the minimum $t_{RESTORE}$ time, the LLC causes the interface to be initialized and restored to normal operation by reasserting the LPS signal. (In Figure 21, the interface is shown in the disabled state with PCLK inactive. However, the interface initialization sequence described here is also executed if the interface is merely reset but not yet disabled.)
- PCLK activated. If the interface is disabled, then the PHY reactivates its PCLK output when it detects that LPS has been reasserted. If the PHY has entered a low-power state, then it takes between 5.3 ms and 7.3 ms for PCLK to be restored; if the PHY is not in a low-power state, then the PCLK is restored within 60 ns. The PCLK output is a 50% duty cycle square wave with a frequency of 49.152 MHz \pm 100 ppm (period of 20.345 ns). During the first 7 cycles of PCLK, the PHY continues to drive the CTL and D terminals low. The LLC is also required to drive its CTL and D outputs low for one of the first 6 cycles of PCLK but otherwise to place its CTL and D outputs in the high-impedance state. The LLC continues to drive its LREQ output low during this time.
- Receive indicated. On the eighth PCLK cycle following reassertion of LPS, the PHY asserts the receive state on the CTL lines and the data-on indication (all 1s) on the D lines for one or more cycles.
- Initialization complete. The PHY asserts the idle state on the CTL lines and logic 0 on the D lines. This indicates that the PHY-LLC interface initialization is complete and normal operation can commence. The PHY now accepts requests from the LLC via the LREQ line.

PRINCIPLES OF OPERATION (1394b INTERFACE)

The TSB41BA3D is designed to operate with an LLC such as the Texas Instruments TSB82AA2 when the BMODE terminal is tied high. Details of operation for the Texas Instruments LLC devices are found in the respective LLC data sheets. The following paragraphs describe the operation of the PHY-LLC interface. This interface is formally specified in the IEEE 1394b-2002 standard.

The interface to the LLC consists of the PCLK, LCLK_PMC, CTL0–CTL1, D0–D7, LREQ, PINT, LPS, and S5_LKON terminals on the TSB41BA3D, as shown in [Figure 22](#).

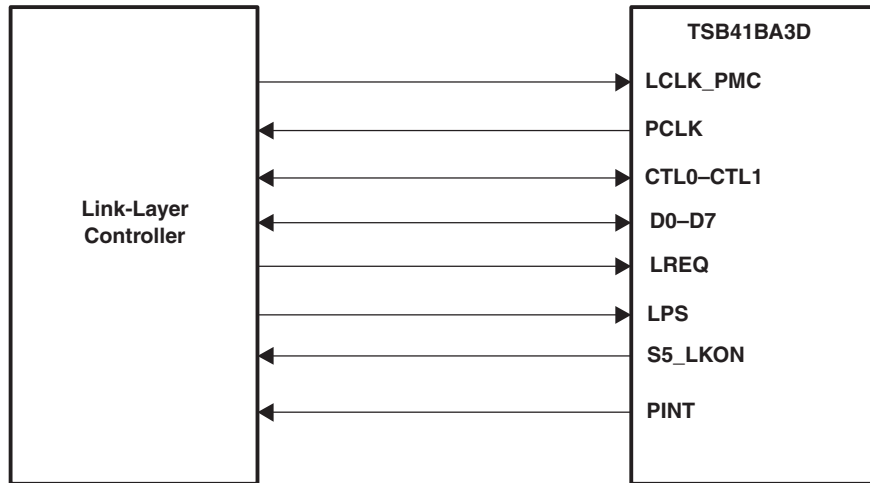

Figure 22. PHY-LLC Interface

The LCLK_PMC terminal provides a clock signal to the PHY. The LLC derives this clock from the PCLK signal and is phase-locked to the PCLK signal. All LLC to PHY transfers are synchronous to LCLK_PMC.

The PCLK terminal provides a 98.304-MHz interface system clock. All control, data, and PHY interrupt signals are synchronized to the rising edge of PCLK.

The CTL0 and CTL1 terminals form a bidirectional control bus, which controls the flow of information and data between the TSB41BA3D and LLC.

The D0–D7 terminals form a bidirectional data bus, which transfers status information, control information, or packet data between the devices. The TSB41BA3D supports S400B, S200B, and S100B data transfers over the D0–D7 data bus. In S400B, S200B, and S100B operation, all Dn terminals are used.

The LREQ terminal is controlled by the LLC to send serial service requests to the PHY in order to request access to the serial bus for packet transmission, read or write PHY registers, or control arbitration acceleration. All data on LREQ is synchronous to LCLK_PMC.

The LPS and S5_LKON terminals are used for power management of the PHY and LLC. The LPS terminal indicates the power status of the LLC, and can be used to reset the PHY-LLC interface or to disable PCLK. The S5_LKON terminal sends a wake-up notification to the LLC and indicates an interrupt to the LLC when either LPS is inactive or the PHY register L bit is 0.

The PINT terminal is used by the PHY for the serial transfer of status, interrupt, and other information to the LLC.

The TSB41BA3D normally controls the CTL0–CTL1 and D0–D7 bidirectional buses. The LLC is allowed to drive these buses only after the LLC has been granted permission to do so by the PHY.

Four operations can occur on the PHY-LLC interface: link service request, status transfer, data transmit, and data receive. The LLC issues a service request to read or write a PHY register or to request the PHY to gain control of the serial bus in order to transmit a packet.

The PHY can initiate a status transfer either autonomously or in response to a register read request from the LLC.

The PHY initiates a receive operation whenever a packet is received from the serial bus.

The PHY initiates a transmit operation after winning control of the serial bus following a bus request by the LLC. The transmit operation is initiated when the PHY grants control of the interface to the LLC.

Table 25 and Table 26 show the encoding of the CTL0–CTL1 bus.

Table 25. CTL Encoding When PHY Has Control of the Bus

CTL0	CTL1	NAME	DESCRIPTION
0	0	Idle	No activity (this is the default mode)
0	1	Status	Status information is being sent from the PHY to the LLC.
1	0	Receive	An incoming packet is being sent from the PHY to the LLC.
1	1	Grant	The LLC has been given control of the bus to send an outgoing packet.

Table 26. CTL Encoding When LLC Has Control of the Bus

CTL0	CTL1	NAME	DESCRIPTION
0	0	Idle	The LLC releases the bus (transmission has been completed).
0	1	Transmit	An outgoing packet is being sent from the LLC to the PHY.
1	0	Reserved	Reserved
1	1	Holation	The LLC is holding the bus while data is being prepared for transmission, or the LLC is sending a request to arbitrate for access to the bus, or the LLC is identifying the end of a subaction gap to the PHY.

LLC Service Request

To request access to the bus, to read or write a PHY register, or to send a link notification to PHY, the LLC sends a serial bit stream on the LREQ terminal as shown in Figure 23.



Each cell represents one clock sample period, and n is the number of bits in the request stream.

Figure 23. LREQ Request Stream

The length of the stream varies depending on the type of request as shown in Table 27.

Table 27. Request Stream Bit Length

REQUEST TYPE	NUMBER OF BITS
Bus request	11
Read register request	10
Write register request	18
Link notification request	6
PHY-link interface reset request	6

Regardless of the type of request, a start bit of 1 is required at the beginning of the stream and a stop bit of 0 is required at the end of the stream. The second through fifth bits of the request stream indicate the type of the request. In the following descriptions, bit LR1 is the most significant and is transmitted first in the request bit stream. The LREQ terminal is normally low.

Table 28 shows the encoding for the request type.

Table 28. Request Type Encoding

LR1–LR4	NAME	DESCRIPTION
0000	Reserved	Reserved
0001	Immed_Req	Immediate request. On detection of idle, the PHY arbitrates for the bus.
0010	Next_Even	Next even request. The PHY arbitrates for the bus to send an asynchronous packet in the even fairness interval phase.
0011	Next_Odd	Next odd request. The PHY arbitrates for the bus to send an asynchronous packet in the odd fairness interval phase.
0100	Current	Current request. The PHY arbitrates for the bus to send an asynchronous packet in the current fairness interval.
0101	Reserved	Reserved
0110	Isoch_Req_Even	Isochronous even request. The PHY arbitrates for the bus to send an isochronous packet in the even isochronous period.
0111	Isoch_Req_Odd	Isochronous odd request. The PHY arbitrates for the bus to send an isochronous packet in the odd isochronous period.
1000	Cyc_Start_Req	Cycle start request. The PHY arbitrates for the bus to send a cycle start packet.
1001	Reserved	Reserved
1010	Reg_Read	Register read request. The PHY returns the specified register contents through a status transfer.
1011	Reg_Write	Register write request. Write to the specified register in the PHY.
1100	Isoch_Phase_Even	Isochronous phase even notification. The link reports to the PHY that: 1) A cycle start packet has been received. 2) The link has set the isochronous phase to even.
1101	Isoch_Phase_Odd	Isochronous phase odd notification. The link reports to the PHY that: 1) A cycle start packet has been received. 2) The link has set the isochronous phase to odd.
1110	Cycle_Start_Due	Cycle start due notification. The link reports to the PHY that a cycle start packet is due for reception.
1111	Reserved	Reserved

For a bus request, the length of the LREQ bit stream is 11 bits as shown in Table 29.

Table 29. Bus Request

BIT(s)	NAME	DESCRIPTION
0	Start bit	Indicates the beginning of the transfer (always 1)
1–4	Request type	Indicates the type of bus request. See Table 28.
5	Request format	Indicates the packet format to be used for packet transmission. See Table 30.
6–9	Request speed	Indicates the speed at which the link sends the data to the PHY. See Table 31 for the encoding of this field.
10	Stop bit	Indicates the end of the transfer (always 0). If bit 6 is 0, then this bit can be omitted.

Table 30 shows the 1-bit request format field used in bus requests.

Table 30. Bus Request Format Encoding

LR5	DATA RATE
0	Link does not request either Beta or legacy packet format for bus transmission
1	Link requests Beta packet format for bus transmission

Table 31 shows the 4-bit request speed field used in bus requests.

Table 31. Bus Request Speed Encoding

LR6–LR9	DATA RATE
0000	S100
0001	Reserved
0010	S200
0011	Reserved
0100	S400
0101	Reserved
0110	S800
All Others	Invalid

NOTE:

The TSB41BA3D accepts a bus request with an invalid speed code and processes the bus request normally. However, during packet transmission for such a request, the TSB41BA3D ignores any data presented by the LLC and transmits a null packet.

For a read register request, the length of the LREQ bit stream is 10 bits as shown in [Table 32](#).

Table 32. Read Register Request

BIT(s)	NAME	DESCRIPTION
0	Start bit	Indicates the beginning of the transfer (always 1)
1–4	Request type	A 1010 indicates this is a read register request.
5–8	Address	Identifies the address of the PHY register to be read
9	Stop bit	Indicates the end of the transfer (always 0)

For a write register request, the length of the LREQ bit stream is 18 bits as shown in [Table 33](#).

Table 33. Write Register Request

BIT(s)	NAME	DESCRIPTION
0	Start bit	Indicates the beginning of the transfer (always 1)
1–4	Request type	A 1011 indicates this is a write register request.
5–8	Address	Identifies the address of the PHY register to be written
9–16	Data	Gives the data that is to be written to the specified register address
17	Stop bit	Indicates the end of the transfer (always 0)

For a link notification request, the length of the LREQ bit stream is 6 bits as shown in [Table 34](#).

Table 34. Link Notification Request

BIT(s)	NAME	DESCRIPTION
0	Start bit	Indicates the beginning of the transfer (always 1)
1–4	Request type	A 1100, 1101, or 1110 indicates this is a link notification request
5	Stop bit	Indicates the end of the transfer (always 0)

For fair or priority access, the LLC sends a bus request at least one clock after the PHY-LLC interface becomes idle. The PHY queues all bus requests and can queue one request of each type. If the LLC issues a different request of the same type, then the new request overwrites any nonserviced request of that type. On the receipt (CTL terminals are asserted to the receive state, 10b) of a packet, queued requests are not cleared by the PHY.

The cycle master node uses a cycle start request (Cyc_Start_Req) to send a cycle start message. After receiving or transmitting a cycle start message, the LLC can issue an isochronous bus request (IsoReq). The PHY clears an isochronous request only when the serial bus has been won.

To send an acknowledge packet, the LLC must issue an immediate bus request (Immed_Req) during the reception of the packet addressed to it. This is required in order to minimize the idle gap between the end of the received packet and the start of the transmitted acknowledge packet. As soon as the received packet ends, the PHY immediately grants control of the bus to the LLC. The LLC sends an acknowledgment to the sender unless the header CRC of the received packet is corrupted. In this case, the LLC does not transmit an acknowledge, but instead cancels the transmit operation and releases the interface immediately; the LLC must not use this grant to send another type of packet. After the interface is released the LLC can proceed with another request.

For write register requests, the PHY loads the specified data into the addressed register as soon as the request transfer is complete. For read register requests, the PHY returns the contents of the addressed register to the LLC at the next opportunity through a PHY status transfer. A write or read register request can be made at any time, including while a bus request is pending. Once a read register request is made, the PHY ignores further read register requests until the register contents are successfully transferred to the LLC. A bus reset does not clear a pending read register request.

Status Transfer

A status transfer is initiated by the PHY when status information is to be transferred to the LLC. Two types of status transfers can occur: bus status transfer and PHY status transfer. Bus status transfers send the following status information: bus reset indications, subaction and arbitration reset gap indications, cycle start indications, and PHY interface reset indications. PHY status transfers send the following information: PHY interrupt indications, unsolicited and solicited PHY register data, bus initialization indications, and PHY-link interface error indications. The PHY uses a different mechanism to send the bus status transfer and the PHY status transfer.

Bus status transfers use the CTL0–CTL1 and D0–D7 terminals to transfer status information. Bus status transfers can occur during idle periods on the PHY-link interface or during packet reception. When the status transfer occurs, a single PCLK cycle of status information is sent to the LLC. The information is sent such that each individual Dn terminal conveys a different bus status transfer event. During any bus status transfer, only one status bit is set. If the PHY-link interface is inactive, then the status information is not sent. When a bus reset on the serial bus occurs, the PHY sends a bus reset indication (via the CTLn and Dn terminals), cancels all packet transfer requests, sets asynchronous and isochronous phases to even, forwards self-ID packets to the link, and sends an unsolicited PHY register 0 status transfer (via the PINT terminal) to the LLC. In the case of a PHY interface reset operation, the PHY-link interface is reset on the following PCLK cycle.

Table 35 shows the definition of the bits during the bus status transfer and Figure 24 shows the timing.

Table 35. Status Bits

STATUS BIT	DESCRIPTION
D0	Bus reset
D1	Arbitration reset gap—odd
D2	Arbitration reset gap—even
D3	Cycle start—odd
D4	Cycle start—even
D5	Subaction gap
D6	PHY interface reset
D7	Reserved

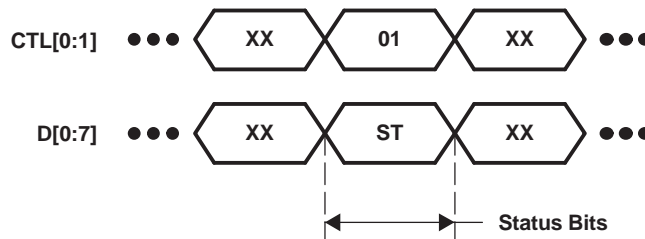

Figure 24. Bus Status Transfer Timing

PHY status transfers use the PINT terminal to send status information serially to the LLC as shown in Figure 25. PHY status transfers (see Table 36) can occur at any time during normal operation. The PHY uses the PHY_INTERRUPT PHY status transfer when required to interrupt the LLC due to a configuration time-out, a cable-power failure, a port interrupt, or an arbitration time-out. When transferring PHY register contents, the PHY uses either the solicited or the unsolicited register read status transfer. The unsolicited register 0 contents are passed to the LLC only during initialization of the serial bus. After any PHY-link interface initialization, the PHY sends a PHY status transfer indicating whether or not a bus reset occurred during the inactive period of the PHY-link interface. If the PHY receives an illegal request from the LLC, then the PHY issues an INTERFACE_ERROR PHY status transfer.



Each cell represents one clock sample period, and n is the number of bits in the request stream.

Figure 25. PINT (PHY Interrupt) Stream

Table 36. PHY Status Transfer Encoding

PI[1:3]	NAME	DESCRIPTION	NUMBER OF BITS
000	NOP	No status indication	5
001	PHY_INTERRUPT	Interrupt indication: configuration time-out, cable-power failure, port event interrupt, or arbitration state machine time-out	5
010	PHY_REGISTER_SOL	Solicited PHY register read	17
011	PHY_REGISTER_UNSol	Unsolicited PHY register read	17
100	PH_RESTORE_NO_RESET	PHY-link interface initialized; no bus resets occurred.	5
101	PH_RESTORE_RESET	PHY-link interface initialized; a bus reset occurred.	5
110	INTERFACE_ERROR	PHY received illegal request.	5
111	Reserved	Reserved	Reserved

Most PHY status transfers are 5 bits long. The transfer consists of a start bit (always 1), followed by a request type (see Table 36), and lastly followed by a stop bit (always 0). The only exception is when the transfer of a register contents occurs. Solicited and unsolicited PHY register read transfers are 17 bits long and include the additional information of the register address and the data contents of the register (see Table 37).

Table 37. Register Read (Solicited and Unsolicited) PHY Status Transfer Encoding

BIT(s)	NAME	DESCRIPTION
0	Start bit	Indicates the beginning of the transfer (always 1)
1–3	Request type	A 010 or a 011 indicates a solicited or unsolicited register contents transfer.
4–7	Address	Identifies the address of the PHY register whose contents are being transferred
8–15	Data	The contents of the register specified in bits 4 through 7
16	Stop bit	Indicates the end of the transfer (always 0)

Receive

When the PHY detects the data-prefix state on the serial bus, it initiates a receive operation by asserting receive on the CTL terminals and a logic 1 on each of the D terminals (data-on indication). The PHY indicates the start of a packet by placing the speed code (encoded as shown in Table 38) on the D terminals, followed by packet data. The PHY holds the CTL terminals in the receive state until the last symbol of the packet has been transferred. The PHY indicates the end of packet data by asserting idle on the CTL terminals. All received packets are transferred to the LLC. Note that the speed code is part of the PHY-LLC protocol and is not included in the calculation of CRC or any other data protection mechanisms.

The PHY can optionally send status information to the LLC at anytime during the data-on indication. Only bus status transfer information can be sent during a data-on indication. The PHY holds the CTL terminals in the status state for 1 PCLK cycle and modifies the D terminals to the correct status state. Note that the status transfer during the data-on indication does not need to be preceded or followed by a data-on indication.

It is possible for the PHY to receive a null packet, which consists of the data-prefix state on the serial bus followed by the data-end state, without any packet data. A null packet is transmitted whenever the packet speed exceeds the capability of the receiving PHY, or whenever the LLC immediately releases the bus without transmitting any data. In this case, the PHY asserts receive on the CTL terminals with the data-on indication (all 1s) on the D terminals, followed by idle on the CTL terminals, without any speed code or data being transferred. In all cases, in normal operation, the TSB41BA3D sends at least one data-on indication before sending the speed code or terminating the receive operation.

The TSB41BA3D also transfers its own self-ID packet, transmitted during the self-ID phase of bus initialization, to the LLC. This packet is transferred to the LLC just as any other received self-ID packet.

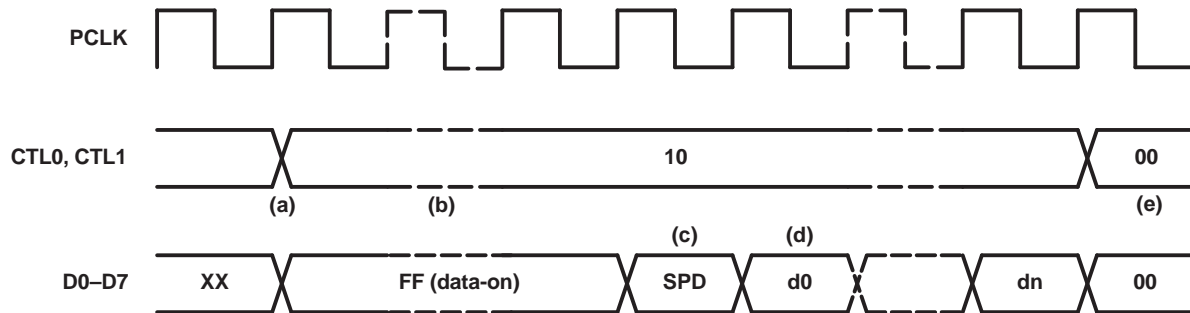

A. SPD = speed code, see Table 38. d0–dn = packet data.

Figure 26. Normal Packet Reception Timing

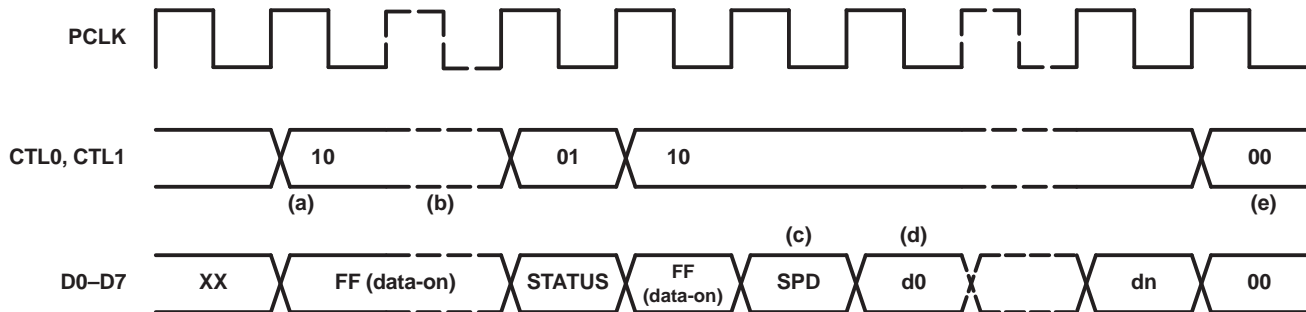

A. SPD = speed code, see Table 38. d0–dn = packet data. STATUS = status bits, see Table 35.

Figure 27. Normal Packet Reception Timing With Optional Bus Status Transfer

The sequence of events for a normal packet reception is as follows:

- a. Receive operation initiated. The PHY indicates a receive operation by asserting receive on the CTL lines. Normally, the interface is idle when receive is asserted. However, the receive operation can interrupt a status transfer operation that is in progress so that the CTL lines can change from status to receive without an intervening idle.
- b. Data-on indication. The PHY can assert the data-on indication code on the D lines for one or more cycles preceding the speed code. The PHY can optionally send a bus status transfer during the data-on indication for one PCLK cycle. During this cycle, the PHY asserts status (01b) on the CTL lines while sending status information on the D lines.
- c. Speed code. The PHY indicates the speed of the received packet by asserting a speed code on the D lines for one cycle immediately preceding packet data. The link decodes the speed code on the first receive cycle for which the D lines are not the data-on code. If the speed code is invalid or indicates a speed higher than that which the link is capable of handling, then the link must ignore the subsequent data.

- d. Receive data. Following the data-on indication (if any) and the speed code, the PHY asserts packet data on the D lines with receive on the CTL lines for the remainder of the receive operation.
- e. Receive operation terminated. The PHY terminates the receive operation by asserting idle on the CTL lines. The PHY asserts at least one idle cycle following a receive operation.

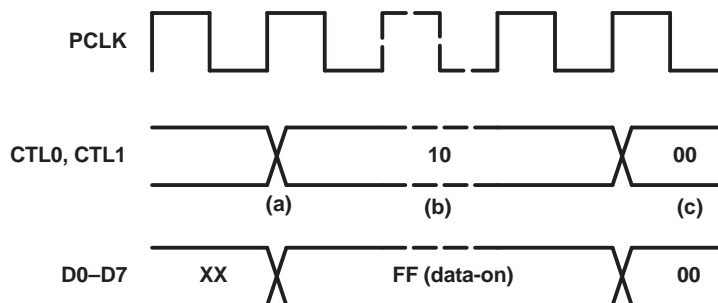

Figure 28. Null Packet Reception Timing

The sequence of events for a null packet reception is as follows:

- a. Receive operation initiated. The PHY indicates a receive operation by asserting receive on the CTL lines. Normally, the interface is idle when receive is asserted. However, the receive operation can interrupt a status transfer operation that is in progress so that the CTL lines can change from status to receive without an intervening idle.
- b. Data-on indication. The PHY asserts the data-on indication code on the D lines for one or more cycles.
- c. Receive operation terminated. The PHY terminates the receive operation by asserting idle on the CTL lines. The PHY asserts at least one idle cycle following a receive operation.

Table 38. Receive Speed Codes and Format

D0–D7 ⁽¹⁾	DATA RATE AND FORMAT
0000 0000	S100 legacy
0000 0001	S100 Beta
0000 0100	S200 legacy
0000 0101	S200 Beta
0000 1000	S400 legacy
0000 1001	S400 Beta
0000 1101	S800 Beta
1111 1111	Data-on indication
All others	Reserved

(1) Y = Output as 1 by PHY, ignored by LLC.
 X = Output as 0 by PHY, ignored by LLC.

Transmit

When the LLC issues a bus request through the LREQ terminal, the PHY arbitrates to gain control of the bus. If the PHY wins arbitration for the serial bus, then the PHY-LLC interface bus is granted to the LLC by asserting the grant state (11b) on the CTL terminals and the grant type on the D terminals for one PCLK cycle, followed by idle for one clock cycle. The LLC then takes control of the bus by asserting either idle (00b), hold (11b), or transmit (01b) on the CTL terminals. If the PHY does not detect a hold or transmit state within eight PCLK cycles, then the PHY takes control of the PHY-link interface. The hold state is used by the LLC to retain control of the bus while it prepares data for transmission. The LLC can assert hold for zero or more clock cycles (that is, the LLC need not assert hold before transmit). During the hold state, the LLC is expected to drive the D lines to 0. The PHY asserts data-prefix on the serial bus during this time.

When the LLC is ready to send data, the LLC asserts transmit on the CTL terminals as well as sending the first

bits of packet data on the D lines. The transmit state is held on the CTL terminals until the last bits of data have been sent. The LLC then asserts either hold or idle on the CTL terminals for one clock cycle. If the hold is asserted, then the hold is immediately followed by one clock cycle of idle. The link then releases the PHY-link interface by putting the CTL and D terminals in a high-impedance state. The PHY then regains control of the PHY-link interface.

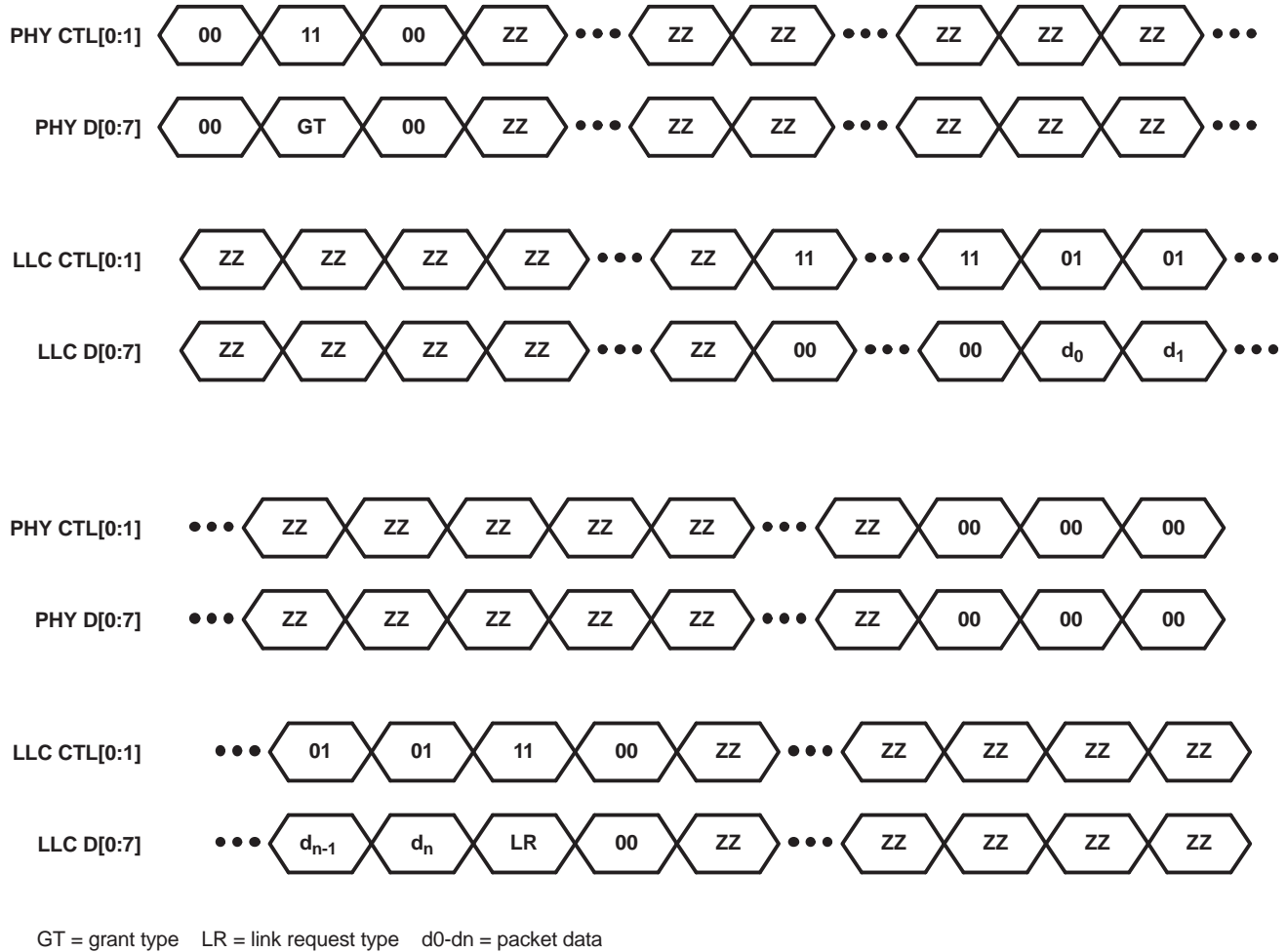

Figure 29. Transmit Packet Timing With Optional Link Request

The hold state asserted at the end of packet transmission allows the LLC to make an additional link request for packet transmission and/or to notify the PHY that the packet marks the end of a subaction. The link requests allowed after packet transmission are listed in [Table 39](#) (note that the link request types allowed during this period are a subset of all of the allowed types of link requests—see [Table 28](#)). The associated speed codes and packet format are listed in [Table 39](#) and [Table 40](#), respectively. If the LLC requests to send an additional packet, then the PHY does not necessarily have to grant the request. If the LLC is notifying the PHY of the end of a subaction, then the LLC sets D4 during the hold state at the end of packet transmission.

Table 39. Link Request Type Encoding During Packet Transmission

D1–D3	Request Type
000	No request
001	Isoch_Req_Odd
010	Isoch_Req_Even
011	Current
100	Next_Even
101	Next_Odd
110	Cyc_Start_Req
111	Reserved

Table 40. Link Request Speed Code Encoding During Packet Transmission

D5–D6	DATA RATE
00	S100
01	S200
10	S400
11	S800

Table 41. Link Request Format Encoding During Packet Transmission

D0	FORMAT
0	Link does not request either Beta or legacy packet format for bus transmission.
1	Link requests Beta packet format for bus transmission.

Table 42. Subaction End Notification Encoding During Packet Transmission

D4	DESCRIPTION
0	Transmitted packet does not represent end of a subaction.
1	Transmitted packet marks the end of a subaction.

The PHY indicates to the link during the GRANT cycle which type of grant is being issued. This indication includes the grant type as well as the grant speed. The link uses the bus grant for transmitting the granted packet type. The link transmits a granted packet type only if its request type exactly matches the granted speed and the granted format.

Table 43. Format Type During Grant Cycle

D0 VALUE DURING GRANT CYCLE	FORMAT
0	Unspecified
1	Beta format

Table 44. Grant Type Values During Grant Cycle

[D1–D3] VALUE DURING GRANT CYCLE	REQUEST TYPE
000	Reserved
001	Reserved
010	Isochronous grant
011	Reserved
100	Reserved
101	Asynchronous grant
110	Cycle start grant
111	Immediate grant

Table 45. Speed Type Values During Grant Cycle

[D5–D6] VALUE DURING GRANT CYCLE	SPEED TYPE
00	S100
01	S200
10	S400
11	S800

PACKAGING INFORMATION

Orderable Device	Status (1)	Package Type	Package Drawing	Pins	Package Qty	Eco Plan (2)	Lead/Ball Finish (6)	MSL Peak Temp (3)	Op Temp (°C)	Device Marking (4/5)	Samples
TSB41BA3DIPFP	ACTIVE	HTQFP	PFP	80	96	Green (RoHS & no Sb/Br)	CU NIPDAU	Level-3-260C-168 HR	-40 to 85	TSB41BA3DI	Samples
TSB41BA3DPFP	ACTIVE	HTQFP	PFP	80	96	Green (RoHS & no Sb/Br)	CU NIPDAU	Level-3-260C-168 HR	0 to 70	TSB41BA3D	Samples

(1) The marketing status values are defined as follows:

ACTIVE: Product device recommended for new designs.

LIFEBUY: TI has announced that the device will be discontinued, and a lifetime-buy period is in effect.

NRND: Not recommended for new designs. Device is in production to support existing customers, but TI does not recommend using this part in a new design.

PREVIEW: Device has been announced but is not in production. Samples may or may not be available.

OBSOLETE: TI has discontinued the production of the device.

(2) Eco Plan - The planned eco-friendly classification: Pb-Free (RoHS), Pb-Free (RoHS Exempt), or Green (RoHS & no Sb/Br) - please check <http://www.ti.com/productcontent> for the latest availability information and additional product content details.

TBD: The Pb-Free/Green conversion plan has not been defined.

Pb-Free (RoHS): TI's terms "Lead-Free" or "Pb-Free" mean semiconductor products that are compatible with the current RoHS requirements for all 6 substances, including the requirement that lead not exceed 0.1% by weight in homogeneous materials. Where designed to be soldered at high temperatures, TI Pb-Free products are suitable for use in specified lead-free processes.

Pb-Free (RoHS Exempt): This component has a RoHS exemption for either 1) lead-based flip-chip solder bumps used between the die and package, or 2) lead-based die adhesive used between the die and leadframe. The component is otherwise considered Pb-Free (RoHS compatible) as defined above.

Green (RoHS & no Sb/Br): TI defines "Green" to mean Pb-Free (RoHS compatible), and free of Bromine (Br) and Antimony (Sb) based flame retardants (Br or Sb do not exceed 0.1% by weight in homogeneous material)

(3) MSL, Peak Temp. - The Moisture Sensitivity Level rating according to the JEDEC industry standard classifications, and peak solder temperature.

(4) There may be additional marking, which relates to the logo, the lot trace code information, or the environmental category on the device.

(5) Multiple Device Markings will be inside parentheses. Only one Device Marking contained in parentheses and separated by a "~" will appear on a device. If a line is indented then it is a continuation of the previous line and the two combined represent the entire Device Marking for that device.

(6) Lead/Ball Finish - Orderable Devices may have multiple material finish options. Finish options are separated by a vertical ruled line. Lead/Ball Finish values may wrap to two lines if the finish value exceeds the maximum column width.

Important Information and Disclaimer: The information provided on this page represents TI's knowledge and belief as of the date that it is provided. TI bases its knowledge and belief on information provided by third parties, and makes no representation or warranty as to the accuracy of such information. Efforts are underway to better integrate information from third parties. TI has taken and continues to take reasonable steps to provide representative and accurate information but may not have conducted destructive testing or chemical analysis on incoming materials and chemicals. TI and TI suppliers consider certain information to be proprietary, and thus CAS numbers and other limited information may not be available for release.

In no event shall TI's liability arising out of such information exceed the total purchase price of the TI part(s) at issue in this document sold by TI to Customer on an annual basis.

MECHANICAL DATA

PFP (S-PQFP-G80)

PowerPAD™ PLASTIC QUAD FLATPACK

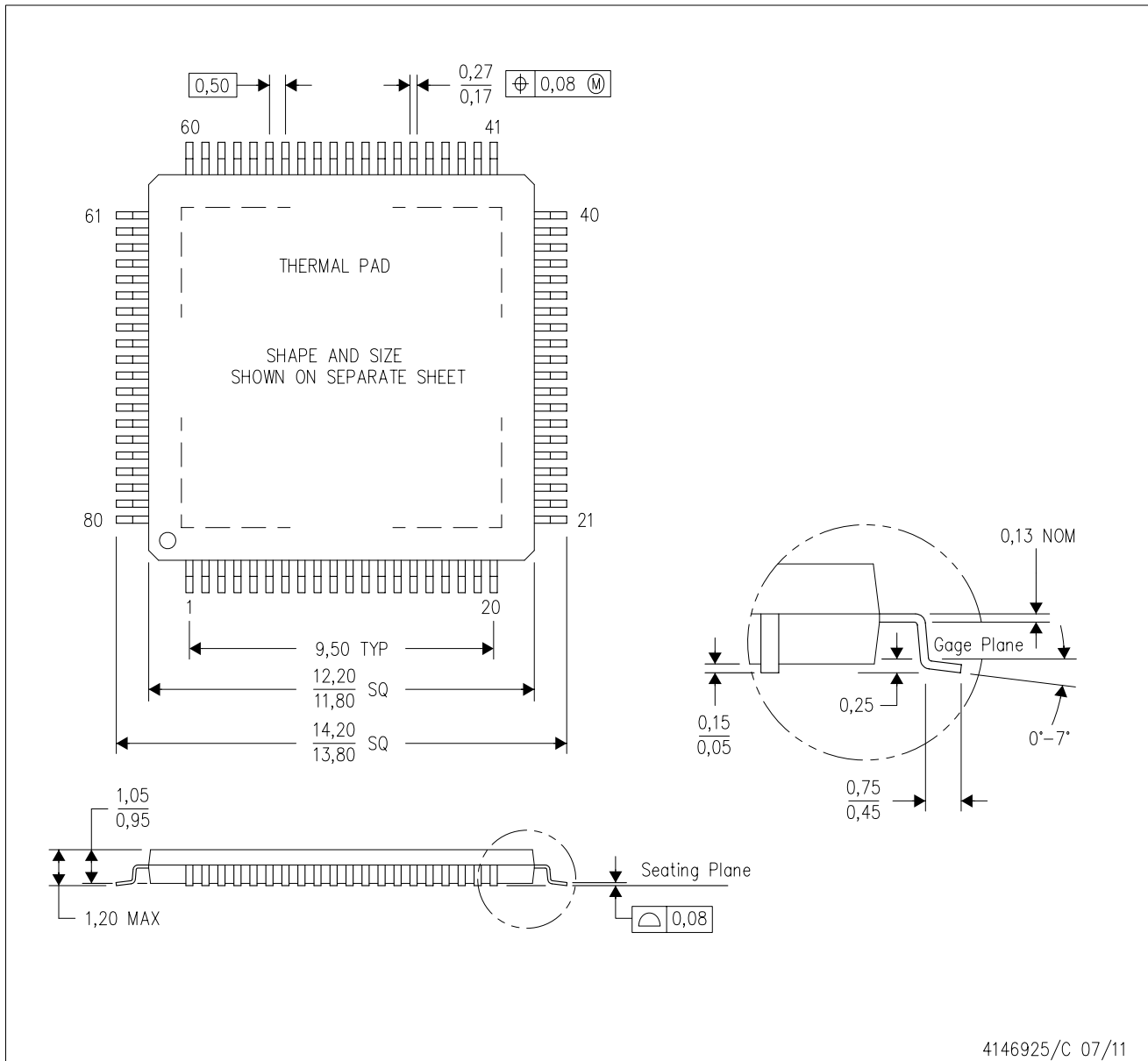

- NOTES:
- A. All linear dimensions are in millimeters.
 - B. This drawing is subject to change without notice.
 - C. Body dimensions do not include mold flash or protrusion
 - D. This package is designed to be soldered to a thermal pad on the board. Refer to Technical Brief, PowerPad Thermally Enhanced Package, Texas Instruments Literature No. SLMA002 for information regarding recommended board layout. This document is available at www.ti.com <<http://www.ti.com>>.
 - E. See the additional figure in the Product Data Sheet for details regarding the exposed thermal pad features and dimensions.
 - F. Falls within JEDEC MS-026

PowerPAD is a trademark of Texas Instruments.

THERMAL PAD MECHANICAL DATA

PFP (S-PQFP-G80)

PowerPAD™ PLASTIC QUAD FLATPACK

THERMAL INFORMATION

This PowerPAD™ package incorporates an exposed thermal pad that is designed to be attached to a printed circuit board (PCB). The thermal pad must be soldered directly to the PCB. After soldering, the PCB can be used as a heatsink. In addition, through the use of thermal vias, the thermal pad can be attached directly to the appropriate copper plane shown in the electrical schematic for the device, or alternatively, can be attached to a special heatsink structure designed into the PCB. This design optimizes the heat transfer from the integrated circuit (IC).

For additional information on the PowerPAD package and how to take advantage of its heat dissipating abilities, refer to Technical Brief, PowerPAD Thermally Enhanced Package, Texas Instruments Literature No. SLMA002 and Application Brief, PowerPAD Made Easy, Texas Instruments Literature No. SLMA004. Both documents are available at www.ti.com.

The exposed thermal pad dimensions for this package are shown in the following illustration.

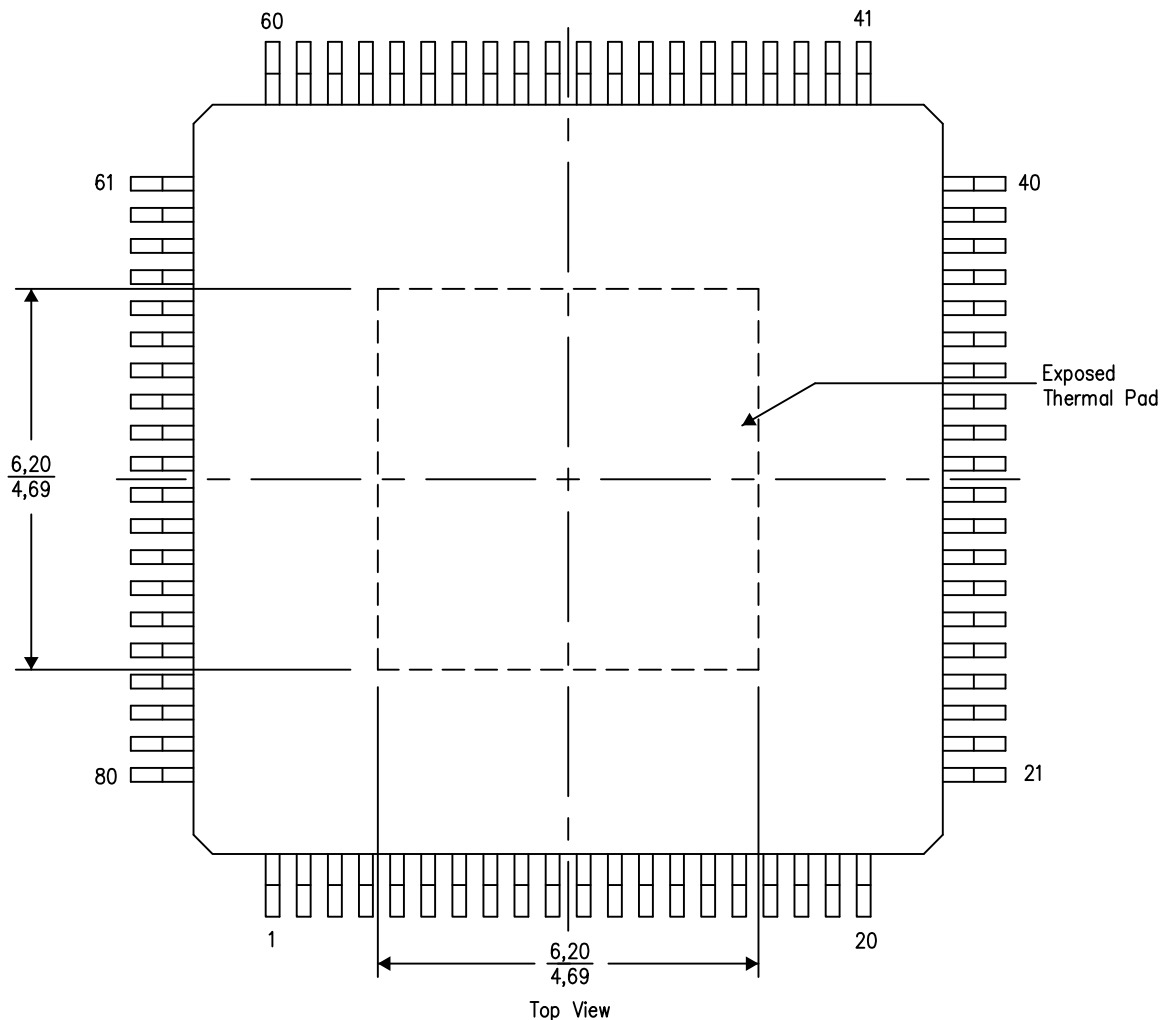

4206327-3/P 05/14

NOTE: A. All linear dimensions are in millimeters

PowerPAD is a trademark of Texas Instruments

PFP (S-PQFP-G80)

PowerPAD™ PLASTIC QUAD FLATPACK

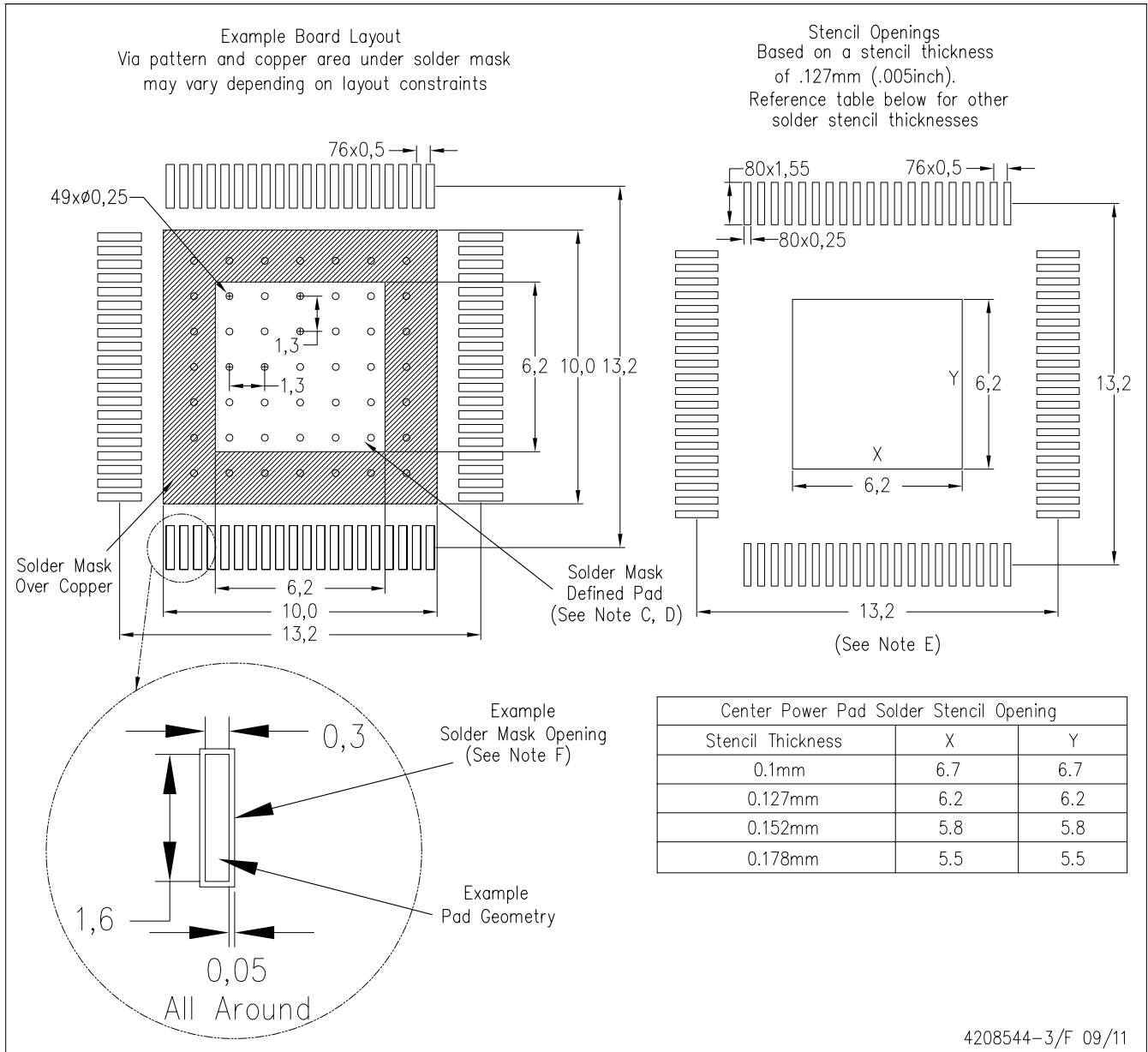

- NOTES:
- All linear dimensions are in millimeters.
 - This drawing is subject to change without notice.
 - Customers should place a note on the circuit board fabrication drawing not to alter the center solder mask defined pad.
 - This package is designed to be soldered to a thermal pad on the board. Refer to Technical Brief, PowerPAD Thermally Enhanced Package, Texas Instruments Literature No. SLMA002, SLMA004, and also the Product Data Sheets for specific thermal information, via requirements, and recommended board layout. These documents are available at www.ti.com <<http://www.ti.com>>. Publication IPC-7351 is recommended for alternate designs.
 - Laser cutting apertures with trapezoidal walls and also rounding corners will offer better paste release. Customers should contact their board assembly site for stencil design recommendations. Example stencil design based on a 50% volumetric metal load solder paste. Refer to IPC-7525 for other stencil recommendations.
 - Customers should contact their board fabrication site for solder mask tolerances between and around signal pads.

PowerPAD is a trademark of Texas Instruments.

IMPORTANT NOTICE

Texas Instruments Incorporated and its subsidiaries (TI) reserve the right to make corrections, enhancements, improvements and other changes to its semiconductor products and services per JESD46, latest issue, and to discontinue any product or service per JESD48, latest issue. Buyers should obtain the latest relevant information before placing orders and should verify that such information is current and complete. All semiconductor products (also referred to herein as "components") are sold subject to TI's terms and conditions of sale supplied at the time of order acknowledgment.

TI warrants performance of its components to the specifications applicable at the time of sale, in accordance with the warranty in TI's terms and conditions of sale of semiconductor products. Testing and other quality control techniques are used to the extent TI deems necessary to support this warranty. Except where mandated by applicable law, testing of all parameters of each component is not necessarily performed.

TI assumes no liability for applications assistance or the design of Buyers' products. Buyers are responsible for their products and applications using TI components. To minimize the risks associated with Buyers' products and applications, Buyers should provide adequate design and operating safeguards.

TI does not warrant or represent that any license, either express or implied, is granted under any patent right, copyright, mask work right, or other intellectual property right relating to any combination, machine, or process in which TI components or services are used. Information published by TI regarding third-party products or services does not constitute a license to use such products or services or a warranty or endorsement thereof. Use of such information may require a license from a third party under the patents or other intellectual property of the third party, or a license from TI under the patents or other intellectual property of TI.

Reproduction of significant portions of TI information in TI data books or data sheets is permissible only if reproduction is without alteration and is accompanied by all associated warranties, conditions, limitations, and notices. TI is not responsible or liable for such altered documentation. Information of third parties may be subject to additional restrictions.

Resale of TI components or services with statements different from or beyond the parameters stated by TI for that component or service voids all express and any implied warranties for the associated TI component or service and is an unfair and deceptive business practice. TI is not responsible or liable for any such statements.

Buyer acknowledges and agrees that it is solely responsible for compliance with all legal, regulatory and safety-related requirements concerning its products, and any use of TI components in its applications, notwithstanding any applications-related information or support that may be provided by TI. Buyer represents and agrees that it has all the necessary expertise to create and implement safeguards which anticipate dangerous consequences of failures, monitor failures and their consequences, lessen the likelihood of failures that might cause harm and take appropriate remedial actions. Buyer will fully indemnify TI and its representatives against any damages arising out of the use of any TI components in safety-critical applications.

In some cases, TI components may be promoted specifically to facilitate safety-related applications. With such components, TI's goal is to help enable customers to design and create their own end-product solutions that meet applicable functional safety standards and requirements. Nonetheless, such components are subject to these terms.

No TI components are authorized for use in FDA Class III (or similar life-critical medical equipment) unless authorized officers of the parties have executed a special agreement specifically governing such use.

Only those TI components which TI has specifically designated as military grade or "enhanced plastic" are designed and intended for use in military/aerospace applications or environments. Buyer acknowledges and agrees that any military or aerospace use of TI components which have **not** been so designated is solely at the Buyer's risk, and that Buyer is solely responsible for compliance with all legal and regulatory requirements in connection with such use.

TI has specifically designated certain components as meeting ISO/TS16949 requirements, mainly for automotive use. In any case of use of non-designated products, TI will not be responsible for any failure to meet ISO/TS16949.

Products

Audio	www.ti.com/audio
Amplifiers	amplifier.ti.com
Data Converters	dataconverter.ti.com
DLP® Products	www.dlp.com
DSP	dsp.ti.com
Clocks and Timers	www.ti.com/clocks
Interface	interface.ti.com
Logic	logic.ti.com
Power Mgmt	power.ti.com
Microcontrollers	microcontroller.ti.com
RFID	www.ti-rfid.com
OMAP Applications Processors	www.ti.com/omap
Wireless Connectivity	www.ti.com/wirelessconnectivity

Applications

Automotive and Transportation	www.ti.com/automotive
Communications and Telecom	www.ti.com/communications
Computers and Peripherals	www.ti.com/computers
Consumer Electronics	www.ti.com/consumer-apps
Energy and Lighting	www.ti.com/energy
Industrial	www.ti.com/industrial
Medical	www.ti.com/medical
Security	www.ti.com/security
Space, Avionics and Defense	www.ti.com/space-avionics-defense
Video and Imaging	www.ti.com/video

TI E2E Community

e2e.ti.com