

## ESD PROTECTED, HIGH-SPEED USB 2.0 (480-Mbps) 1:2 MULTIPLEXER/DEMULTIPLEXER SWITCH WITH SINGLE ENABLE

Check for Samples: [TS3USB221A-Q1](#)

### FEATURES

- Qualified for Automotive Applications
- AEC-Q100 Qualified With the Following Results:
  - Device Temperature Grade 1: –40°C to 125°C Ambient Operating Temperature Range
  - Device HBM ESD Classification Level H2
  - Device CDM ESD Classification Level C5
- $V_{CC}$  Operation at 2.5 V to 3.3 V
- $V_{I/O}$  Accepts Signals Up to 5.5 V
- 1.8-V Compatible Control-Pin Inputs
- Low-Power Mode When  $\overline{OE}$  Is Disabled (1  $\mu$ A)
- $r_{ON} = 16 \Omega$  Maximum

- $\Delta r_{ON} = 0.2 \Omega$  Typical
- $C_{io(on)} = 6$  pF Typical
- Low Power Consumption (30  $\mu$ A Maximum)
- High Bandwidth (900 MHz Typical)
- ESD Performance Tested Per JESD 22
  - 7000-V Human-Body Model (A114-B, Class II)
  - 1000-V Charged-Device Model (C101)
- ESD Performance I/O to GND Per JESD 22
  - 12-kV Human-Body Model

### APPLICATIONS

- Routes Signals for USB 1.0, 1.1, and 2.0

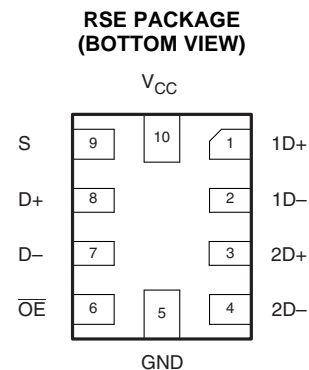
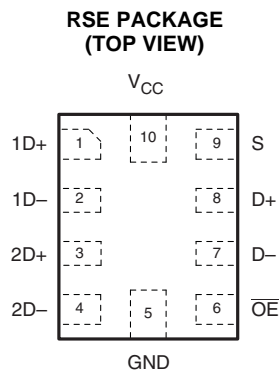

### DESCRIPTION

The TS3USB221A is a high-bandwidth switch specially designed for the switching of high-speed USB 2.0 signals in handset and consumer applications, such as cell phones, digital cameras, and notebooks with hubs or controllers with limited USB I/Os. The wide bandwidth (900 MHz) of this switch allows signals to pass with minimum edge and phase distortion. The device multiplexes differential outputs from a USB host device to one of two corresponding outputs. The switch is bidirectional and offers little or no attenuation of the high-speed signals at the outputs. It is designed for low bit-to-bit skew and high channel-to-channel noise isolation, and is compatible with various standards, such as high-speed USB 2.0 (480 Mbps).

The TS3USB221A integrates ESD protection cells on all pins, is available in a tiny  $\mu$ QFN package (2.0 mm  $\times$  1.5 mm) and is characterized over the free air temperature range from –40°C to 125°C.



Please be aware that an important notice concerning availability, standard warranty, and use in critical applications of Texas Instruments semiconductor products and disclaimers thereto appears at the end of this data sheet.

**ORDERING INFORMATION<sup>(1)(2)</sup>**

T <sub>A</sub>	ORDERABLE PART NUMBER	TOP-SIDE MARKING
-40°C to 125°C	TS3USB221AQRSERQ1	OFW

- (1) For the most current package and ordering information, see the Package Option Addendum at the end of this document, or see the TI web site at [www.ti.com](http://www.ti.com).
- (2) Package drawings, thermal data, and symbolization are available at [www.ti.com/packaging](http://www.ti.com/packaging).

**PIN DESCRIPTION**

NAME	DESCRIPTION
$\overline{OE}$	Bus-switch enable
S	Select input
D	Bus A
nD	Bus B

**TRUTH TABLE**

S	$\overline{OE}$	FUNCTION
X	H	Disconnect
L	L	D = 1D
H	L	D = 2D

**BLOCK DIAGRAM**

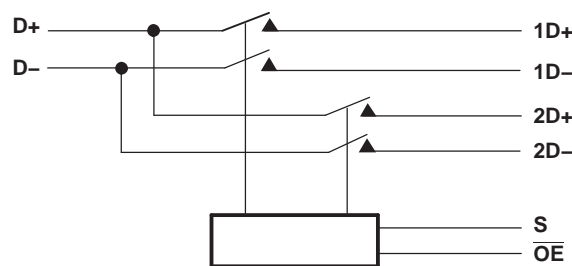
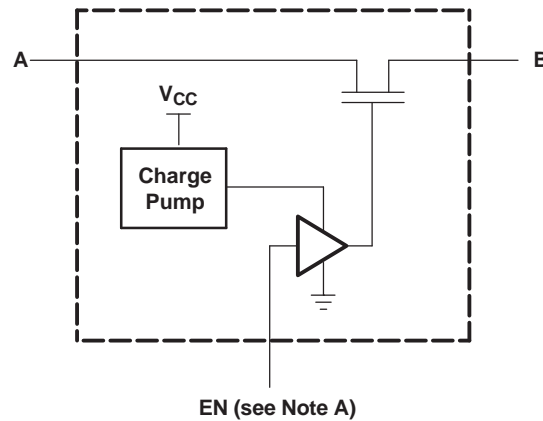

Figure 1. SIMPLIFIED SCHEMATIC, EACH FET SWITCH (SW)



A. EN is the internal enable signal applied to the switch.

**ABSOLUTE MAXIMUM RATINGS<sup>(1)</sup>**

over operating free-air temperature range (unless otherwise noted)

		MIN	MAX	UNIT
V <sub>CC</sub>	Supply voltage range	-0.5	4.6	V
V <sub>IN</sub>	Control input voltage range <sup>(2)</sup> <sup>(3)</sup>	-0.5	7	V
V <sub>I/O</sub>	Switch I/O voltage range <sup>(2)</sup> <sup>(3)</sup> <sup>(4)</sup>	-0.5	7	V
I <sub>IK</sub>	Control input clamp current	V <sub>IN</sub> < 0	-50	mA
I <sub>I/OK</sub>	I/O port clamp current	V <sub>I/O</sub> < 0	-50	mA
I <sub>I/O</sub>	ON-state switch current <sup>(5)</sup>		±120	mA
	Continuous current through V <sub>CC</sub> or GND		±100	mA
T <sub>stg</sub>	Storage temperature range	-65	150	°C
ESD Ratings	Human-body model (HBM) AEC-Q100 Classification Level H2		2	kV
	Charged-device model (CDM) AEC-Q100 Classification C5		2	

(1) Stresses beyond those listed under "absolute maximum ratings" may cause permanent damage to the device. These are stress ratings only, and functional operation of the device at these or any other conditions beyond those indicated under "recommended operating conditions" is not implied. Exposure to absolute-maximum-rated conditions for extended periods may affect device reliability.

(2) All voltages are with respect to ground, unless otherwise specified.

(3) The input and output voltage ratings may be exceeded if the input and output clamp-current ratings are observed.

(4) V<sub>I</sub> and V<sub>O</sub> are used to denote specific conditions for V<sub>I/O</sub>.

(5) I<sub>I</sub> and I<sub>O</sub> are used to denote specific conditions for I<sub>I/O</sub>.

**PACKAGE THERMAL IMPEDANCE**

over operating free-air temperature range (unless otherwise noted)

			UNIT
θ <sub>JA</sub>	Package thermal impedance <sup>(1)</sup>	RSE package	243 °C/W
θ <sub>JC</sub>	Junction-to-case thermal resistance		84 °C/W

(1) The package thermal impedance is calculated in accordance with JESD 51-7.

**RECOMMENDED OPERATING CONDITIONS**

		MIN	MAX	UNIT
V <sub>CC</sub>	Supply voltage	2.3	3.6	V
V <sub>IH</sub>	High-level control input voltage	V <sub>CC</sub> = 2.3 V to 2.7 V	0.46 × V <sub>CC</sub>	V
		V <sub>CC</sub> = 2.7 V to 3.6 V	0.46 × V <sub>CC</sub>	
V <sub>IL</sub>	Low-level control input voltage	V <sub>CC</sub> = 2.3 V to 2.7 V	0.25 × V <sub>CC</sub>	V
		V <sub>CC</sub> = 2.7 V to 3.6 V	0.25 × V <sub>CC</sub>	
V <sub>I/O</sub>	Data input/output voltage	0	5.5	V
T <sub>A</sub>	Operating free-air temperature	-40	125	°C

**ELECTRICAL CHARACTERISTICS<sup>(1)</sup>**

over operating free-air temperature range (unless otherwise noted)

PARAMETER		TEST CONDITIONS		MIN	TYP <sup>(2)</sup>	MAX	UNIT	
$V_{IK}$		$V_{CC} = 3.6\text{ V}, 2.7\text{ V}, I_I = -18\text{ mA}$				-1.8	V	
$I_{IN}$	Control inputs	$V_{CC} = 3.6\text{ V}, 2.7\text{ V}, 0\text{ V}, V_{IN} = 0\text{ V to } 3.6\text{ V}$				±1	µA	
$I_{OZ}$ <sup>(3)</sup>		$V_{CC} = 3.6\text{ V}, 2.7\text{ V}, V_O = 0\text{ V to } 5.25\text{ V}, V_I = 0\text{ V}, V_{IN} = V_{CC}\text{ or GND}, \text{ Switch OFF}$				±1	µA	
$I_{(OFF)}$		$V_{CC} = 0\text{ V}$		$V_{IO} = 0\text{ V to } 5.25\text{ V}$		±2	µA	
				$V_{IO} = 0\text{ V to } 3.6\text{ V}$		±2		
				$V_{IO} = 0\text{ V to } 2.7\text{ V}$		±1		
$I_{CC}$		$V_{CC} = 3.6\text{ V}, 2.7\text{ V}, V_{IN} = V_{CC}\text{ or GND}, I_{IO} = 0\text{ V}, \text{ Switch ON or OFF}$				30	µA	
$I_{CC}$ (low power mode)		$V_{CC} = 3.6\text{ V}, 2.7\text{ V}, V_{IN} = V_{CC}\text{ or GND}, \text{ Switch disabled, } \overline{OE}\text{ in high state}$				1	µA	
$\Delta I_{CC}$ <sup>(4)</sup>	Control inputs	One input at 1.8 V, Other inputs at $V_{CC}$ or GND		$V_{CC} = 3.6\text{ V}$		20	µA	
				$V_{CC} = 2.7\text{ V}$		0.5		
$C_{in}$	Control inputs	$V_{CC} = 3.3\text{ V}, 2.5\text{ V}, V_{IN} = V_{CC}\text{ or } 0\text{ V}$			1.5	2.5	pF	
$C_{io(OFF)}$		$V_{CC} = 3.3\text{ V}, 2.5\text{ V}, V_{IO} = V_{CC}\text{ or } 0\text{ V}, \text{ Switch OFF}$			3.5	5	pF	
$C_{io(ON)}$		$V_{CC} = 3.3\text{ V}, 2.5\text{ V}, V_{IO} = V_{CC}\text{ or } 0\text{ V}, \text{ Switch ON}$			6	7.5	pF	
$r_{ON}$ <sup>(5)</sup>		$V_{CC} = 3\text{ V}, 2.3\text{ V}$		$T_A = 25^\circ\text{C}$		$V_I = 0\text{ V}, I_O = 30\text{ mA}$	3	6
						$V_I = 2.4\text{ V}, I_O = -15\text{ mA}$	3.4	6
				$T_A = 125^\circ\text{C}$		$V_I = 0\text{ V}, I_O = 30\text{ mA}$	6	10
						$V_I = 2.4\text{ V}, I_O = -15\text{ mA}$	10	16
$\Delta r_{ON}$		$V_{CC} = 3\text{ V}, 2.3\text{ V}$				$V_I = 0\text{ V}, I_O = 30\text{ mA}$	0.2	Ω
						$V_I = 1.7\text{ V}, I_O = -15\text{ mA}$	0.2	
$r_{ON(Flat)}$		$V_{CC} = 3\text{ V}, 2.3\text{ V}$				$V_I = 0\text{ V}, I_O = 30\text{ mA}$	1	Ω
						$V_I = 1.7\text{ V}, I_O = -15\text{ mA}$	1	

(1)  $V_{IN}$  and  $I_{IN}$  refer to control inputs.  $V_I$ ,  $V_O$ ,  $I_I$ , and  $I_O$  refer to data pins.

(2) All typical values are at  $V_{CC} = 3.3\text{ V}$  (unless otherwise noted),  $T_A = 25^\circ\text{C}$ .

(3) For I/O ports, the parameter  $I_{OZ}$  includes the input leakage current.

(4) This is the increase in supply current for each input that is at the specified TTL voltage level, rather than  $V_{CC}$  or GND.

(5) Measured by the voltage drop between the A and B terminals at the indicated current through the switch. ON-state resistance is determined by the lower of the voltages of the two (A or B) terminals.

**DYNAMIC ELECTRICAL CHARACTERISTICS**

 over operating range,  $T_A = -40^\circ\text{C to } 125^\circ\text{C}, V_{CC} = 3.3\text{ V } \pm 10\%, \text{ GND} = 0\text{ V}$ 

PARAMETER		TEST CONDITIONS		TYP	UNIT
$X_{TALK}$	Crosstalk	$R_L = 50, f = 250\text{ MHz}$		-40	dB
$O_{IRR}$	OFF isolation	$R_L = 50, f = 250\text{ MHz}$		-41	dB
BW	Bandwidth (-3 dB)	$R_L = 50$		0.9	GHz

## DYNAMIC ELECTRICAL CHARACTERISTICS

over operating range,  $T_A = -40^\circ\text{C}$  to  $125^\circ\text{C}$ ,  $V_{CC} = 2.5\text{ V} \pm 10\%$ ,  $GND = 0\text{ V}$

PARAMETER	TEST CONDITIONS	TYP	UNIT
$X_{TALK}$ Crosstalk	$R_L = 50$ , $f = 250\text{ MHz}$	-39	dB
$O_{IRR}$ OFF isolation	$R_L = 50$ , $f = 250\text{ MHz}$	-40	dB
BW Bandwidth (3 dB)	$R_L = 50$	0.9	GHz

## SWITCHING CHARACTERISTICS

over operating range,  $T_A = -40^\circ\text{C}$  to  $125^\circ\text{C}$ ,  $V_{CC} = 3.3\text{ V} \pm 10\%$ ,  $GND = 0\text{ V}$

PARAMETER	MIN	TYP <sup>(1)</sup>	MAX	UNIT
$t_{pd}$ Propagation delay <sup>(2) (3)</sup>		0.25		ns
$t_{ON}$ Line enable time	S to D, nD		30	ns
	$\overline{OE}$ to D, nD		17	
$t_{OFF}$ Line disable time	S to D, nD		12	ns
	$\overline{OE}$ to D, nD		10	
$t_{SK(O)}$ Output skew between center port to any other port <sup>(2)</sup>		0.1	0.2	ns
$t_{SK(P)}$ Skew between opposite transitions of the same output ( $t_{PHL} - t_{PLH}$ ) <sup>(2)</sup>		0.1	0.2	ns

(1) For Max or Min conditions, use the appropriate value specified under Electrical Characteristics for the applicable device type.

(2) Specified by design

(3) The bus switch contributes no propagational delay other than the RC delay of the on resistance of the switch and the load capacitance. The time constant for the switch alone is of the order of 0.25 ns for 10-pF load. Since this time constant is much smaller than the rise/fall times of typical driving signals, it adds very little propagational delay to the system. Propagational delay of the bus switch, when used in a system, is determined by the driving circuit on the driving side of the switch and its interactions with the load on the driven side.

## SWITCHING CHARACTERISTICS

over operating range,  $T_A = -40^\circ\text{C}$  to  $125^\circ\text{C}$ ,  $V_{CC} = 2.5\text{ V} \pm 10\%$ ,  $GND = 0\text{ V}$

PARAMETER	MIN	TYP <sup>(1)</sup>	MAX	UNIT
$t_{pd}$ Propagation delay <sup>(2) (3)</sup>		0.25		ns
$t_{ON}$ Line enable time	S to D, nD		50	ns
	$\overline{OE}$ to D, nD		32	
$t_{OFF}$ Line disable time	S to D, nD		23	ns
	$\overline{OE}$ to D, nD		12	
$t_{SK(O)}$ Output skew between center port to any other port <sup>(2)</sup>		0.1	0.2	ns
$t_{SK(P)}$ Skew between opposite transitions of the same output ( $t_{PHL} - t_{PLH}$ ) <sup>(2)</sup>		0.1	0.2	ns

(1) For Max or Min conditions, use the appropriate value specified under Electrical Characteristics for the applicable device type.

(2) Specified by design

(3) The bus switch contributes no propagational delay other than the RC delay of the on resistance of the switch and the load capacitance. The time constant for the switch alone is of the order of 0.25 ns for 10-pF load. Since this time constant is much smaller than the rise/fall times of typical driving signals, it adds very little propagational delay to the system. Propagational delay of the bus switch, when used in a system, is determined by the driving circuit on the driving side of the switch and its interactions with the load on the driven side.

APPLICATION INFORMATION

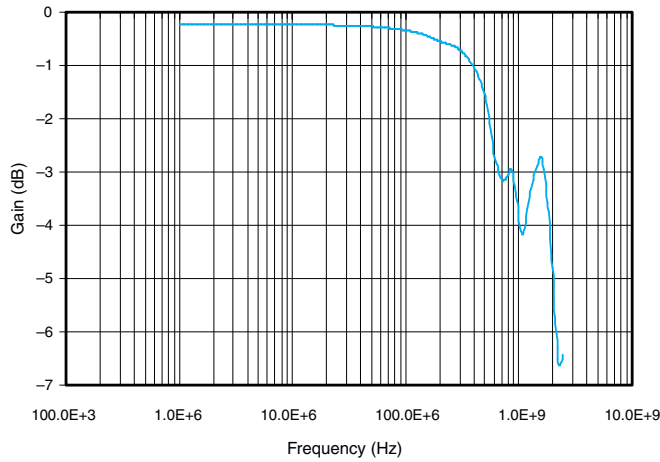

Figure 2. Gain vs Frequency

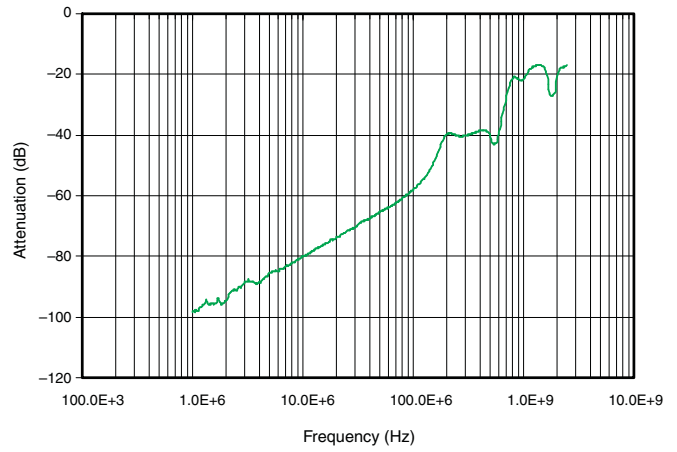

Figure 3. OFF Isolation vs Frequency

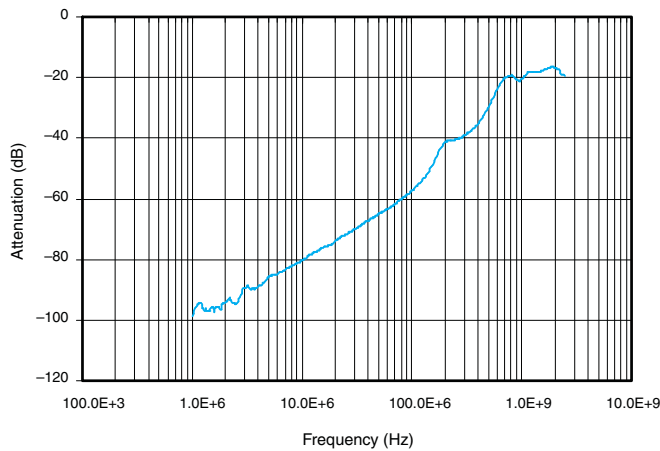

Figure 4. Crosstalk vs Frequency

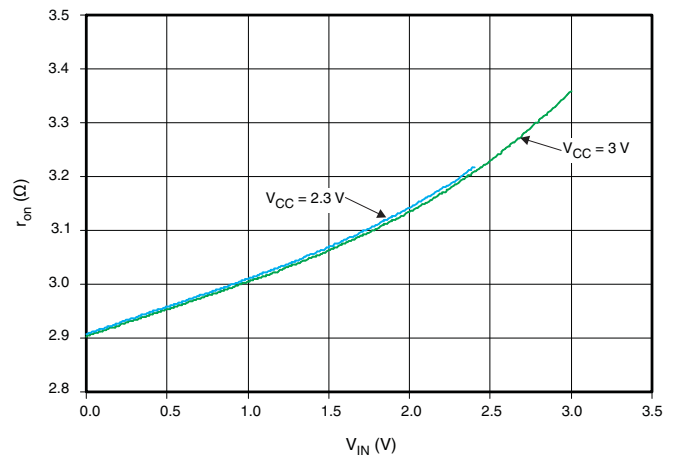

Figure 5.  $r_{on}$  vs  $V_{IN}$  ( $I_{OUT} = -15$  mA)

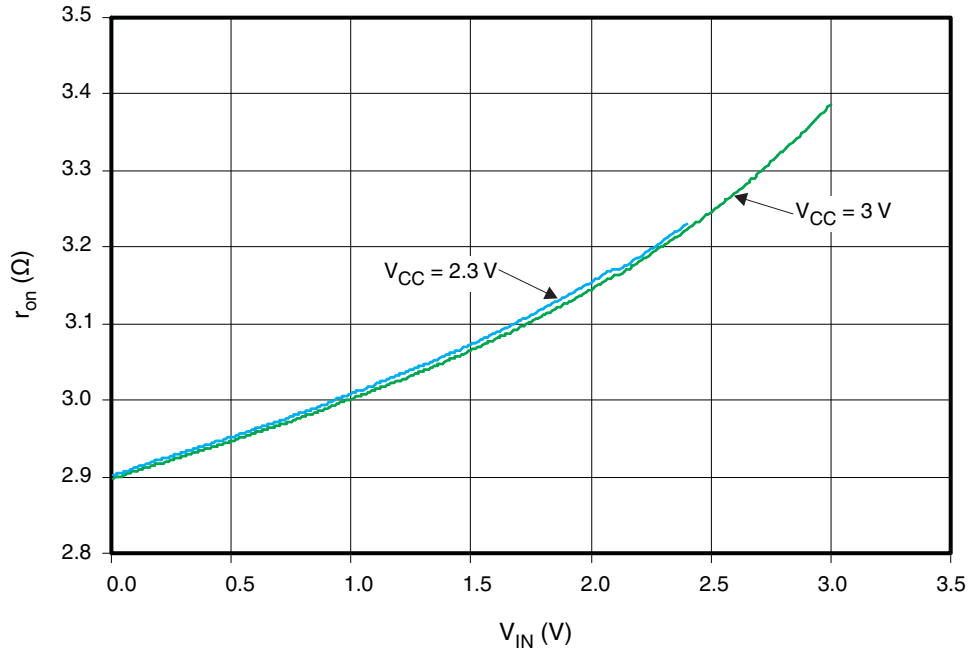

Figure 6. r<sub>ON</sub> vs V<sub>IN</sub> (I<sub>OUT</sub> = 30 mA)

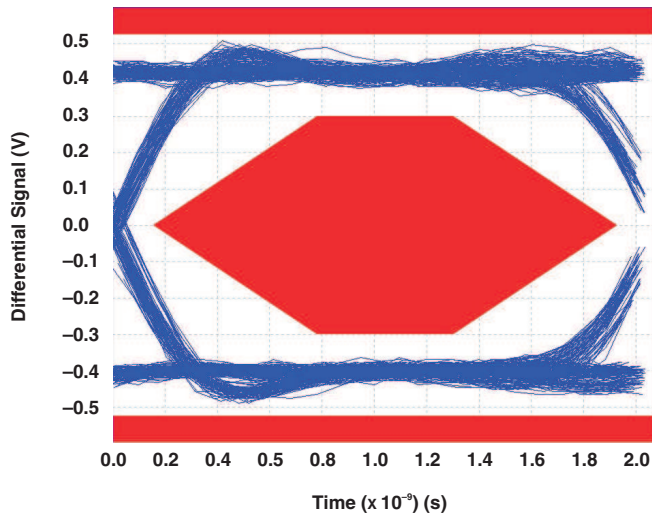

Figure 7. Eye Pattern: 480-Mbps USB Signal With No Switch (Through Path)

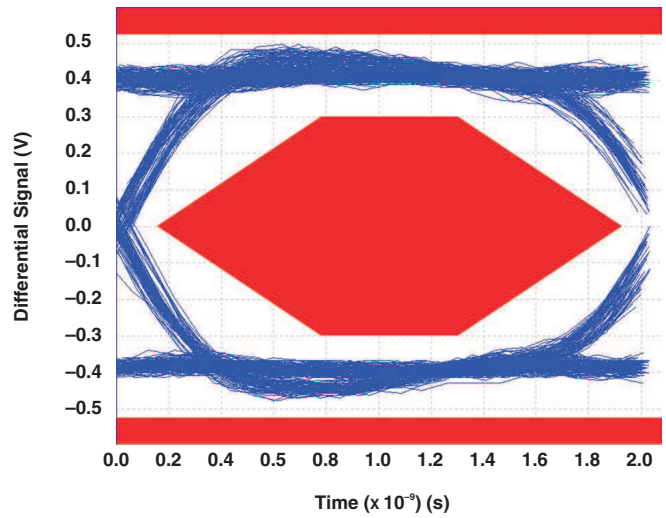

Figure 8. Eye Pattern: 480-Mbps USB Signal With Switch NC Path

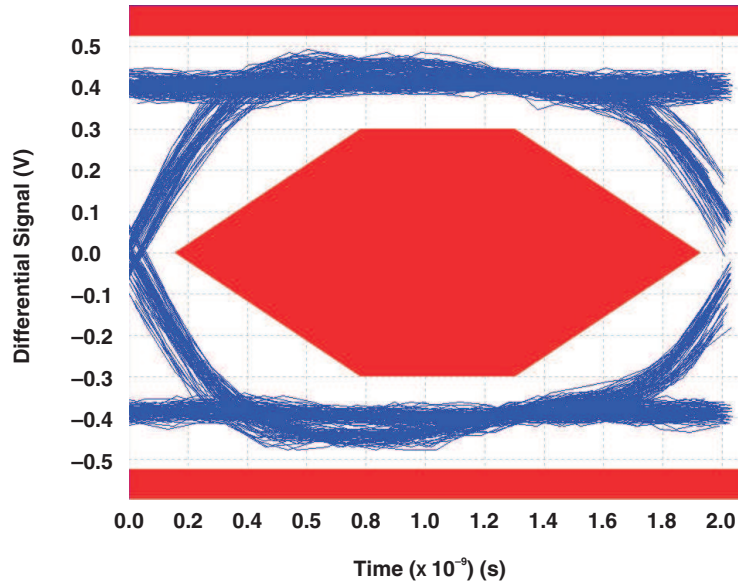
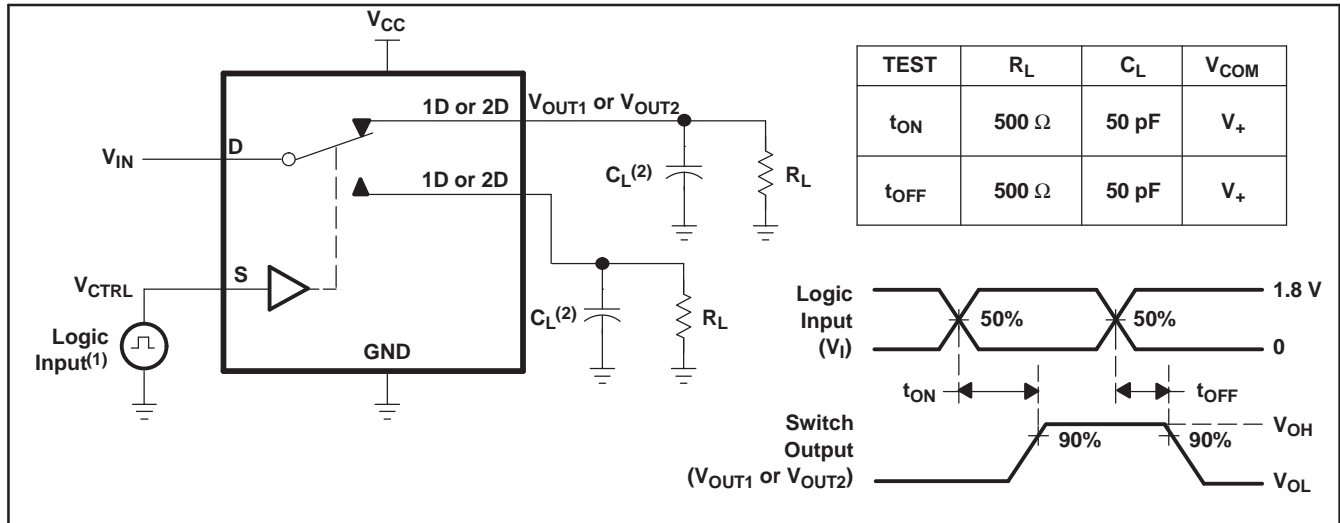

Figure 9. Eye Pattern: 480-Mbps USB Signal With Switch NO Path

PARAMETER MEASUREMENT INFORMATION



- (1) All input pulses are supplied by generators having the following characteristics: PRR ≤ 10 MHz, Z<sub>O</sub> = 50 Ω, t<sub>r</sub> < 5 ns, t<sub>f</sub> < 5 ns.
- (2) C<sub>L</sub> includes probe and jig capacitance.

Figure 10. Turn-On (t<sub>ON</sub>) and Turn-Off Time (t<sub>OFF</sub>)

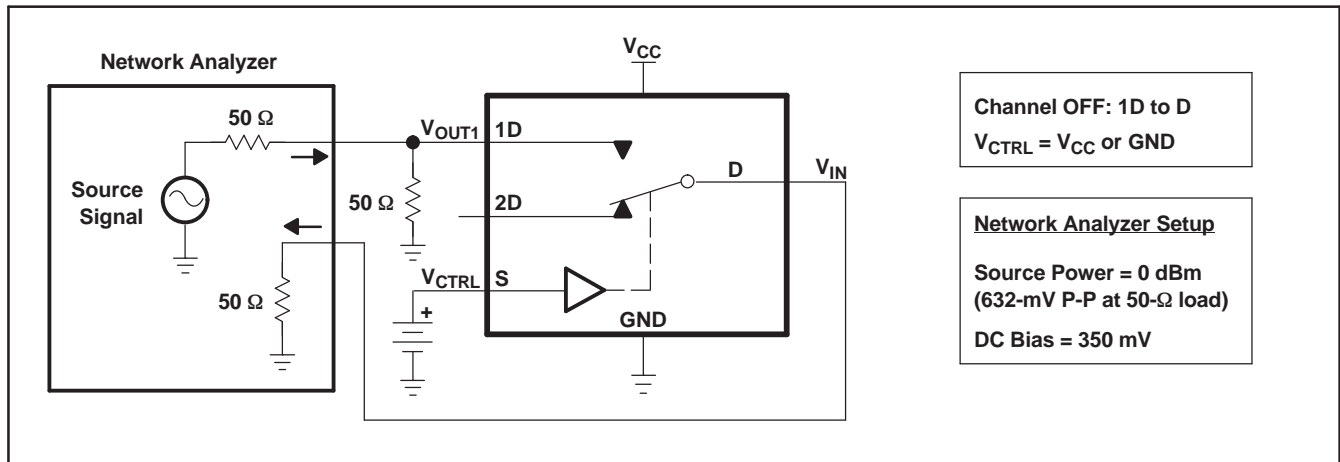

Figure 11. OFF Isolation (O<sub>ISO</sub>)

PARAMETER MEASUREMENT INFORMATION (continued)

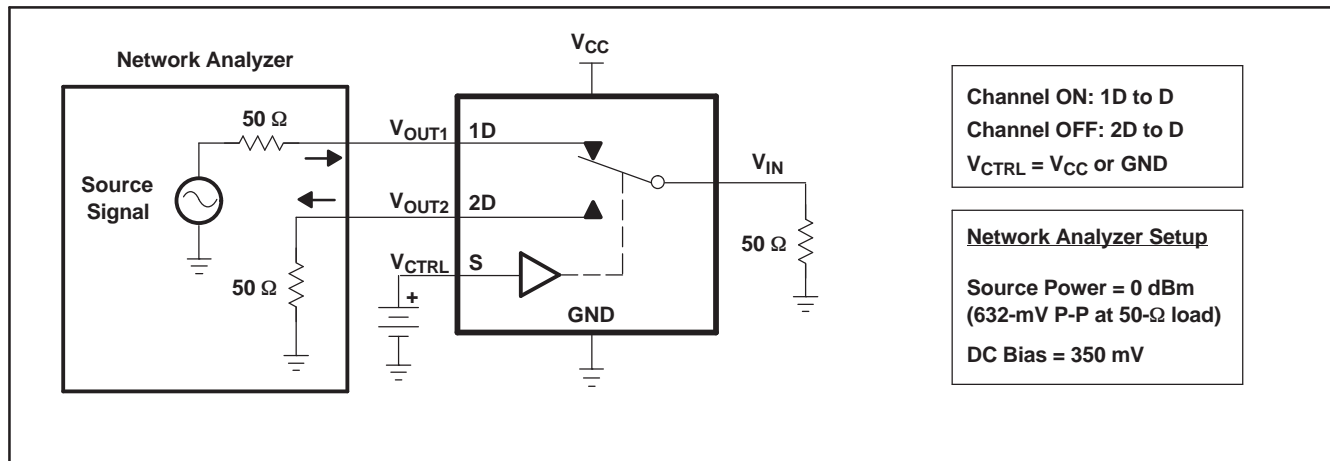

Figure 12. Crosstalk ( $X_{TALK}$ )

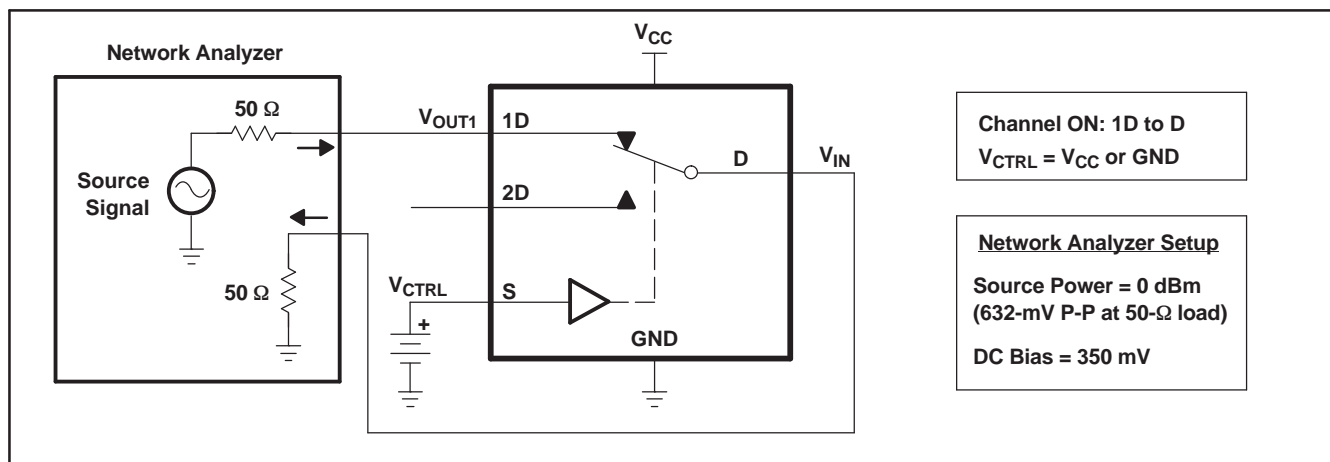

Figure 13. Bandwidth (BW)

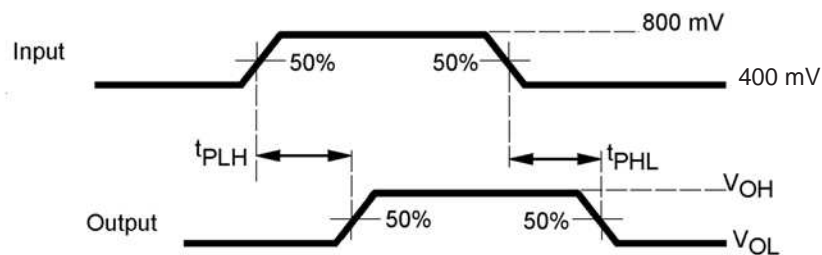

Figure 14. Propagation Delay

PARAMETER MEASUREMENT INFORMATION (continued)

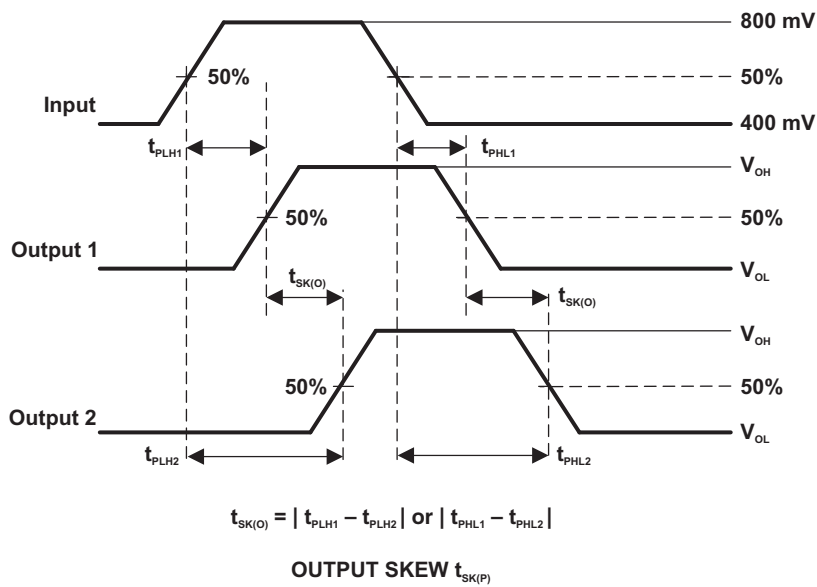
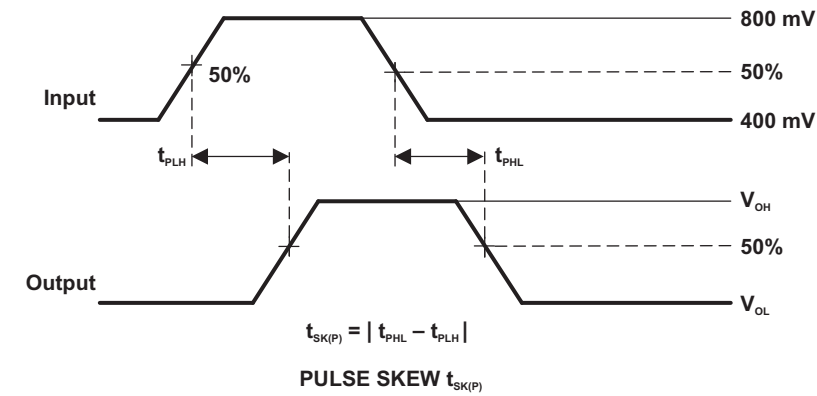

Figure 15. Skew Test

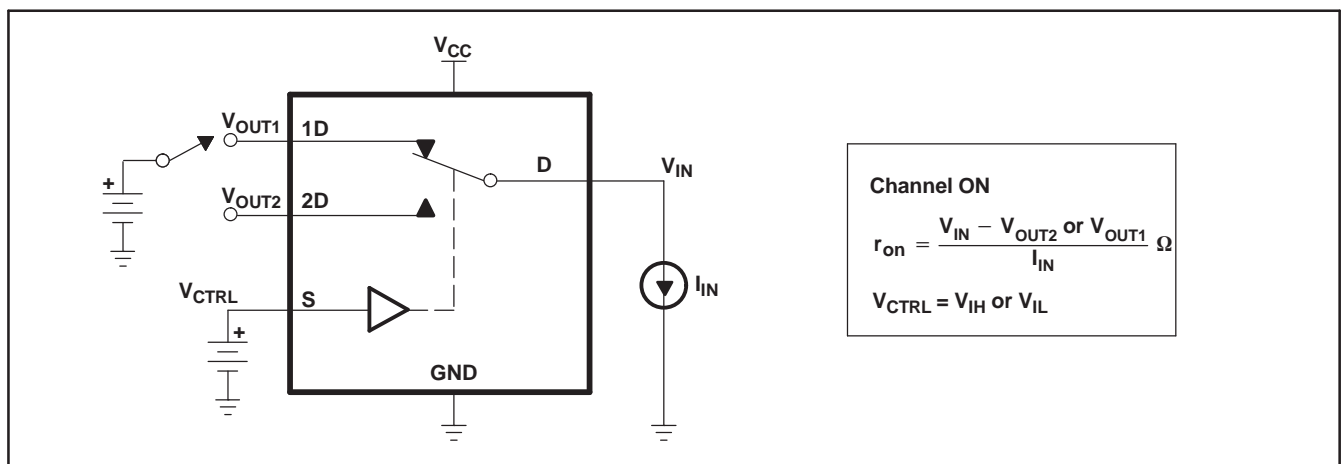

Figure 16. ON-State Resistance ( $r_{on}$ )

PARAMETER MEASUREMENT INFORMATION (continued)

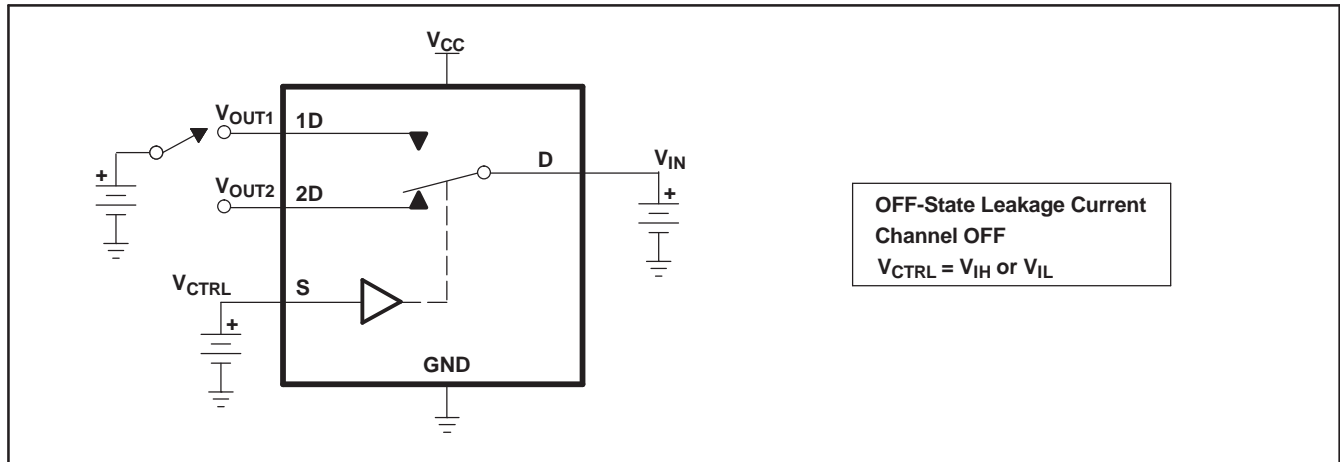

Figure 17. OFF-State Leakage Current

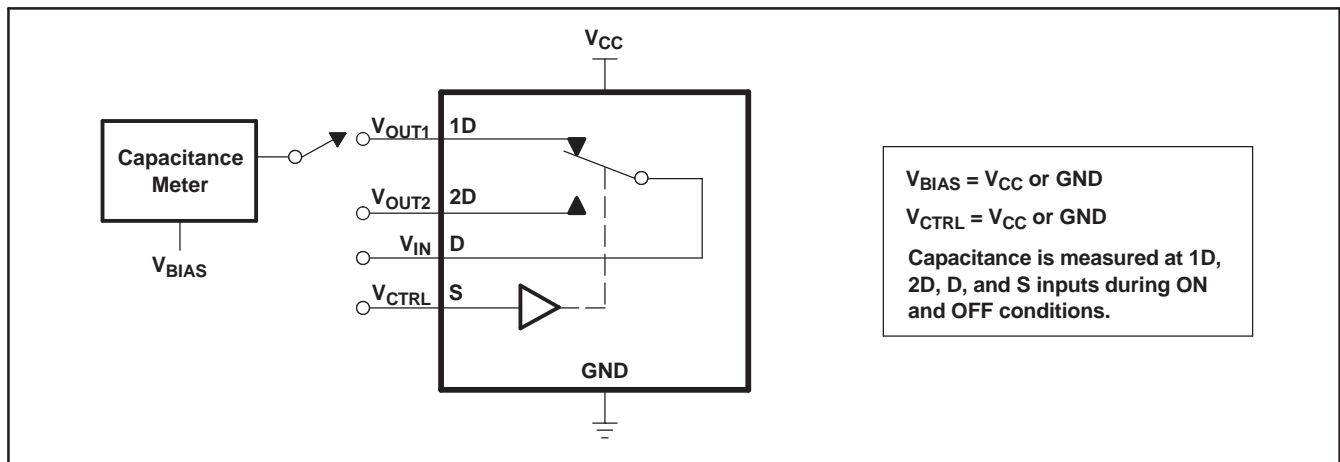

Figure 18. Capacitance

## REVISION HISTORY

Changes from Revision B (July, 2011) to Revision C	Page
• Added AEC-Q100 info to Features. ....	1
• Added "Per JESD 22" to ESD Performance I/O to GND in Features. ....	1
• Removed package column in Ordering Information table. ....	2
• Added ESD ratings to Abs Max table. ....	4

**PACKAGING INFORMATION**

Orderable Device	Status (1)	Package Type	Package Drawing	Pins	Package Qty	Eco Plan (2)	Lead/Ball Finish (6)	MSL Peak Temp (3)	Op Temp (°C)	Device Marking (4/5)	Samples
TS3USB221AQRSERQ1	ACTIVE	UQFN	RSE	10	3000	Green (RoHS & no Sb/Br)	CU NIPDAUAG	Level-3-260C-168 HR	-40 to 125	OFW	Samples

(1) The marketing status values are defined as follows:

**ACTIVE:** Product device recommended for new designs.

**LIFEBUY:** TI has announced that the device will be discontinued, and a lifetime-buy period is in effect.

**NRND:** Not recommended for new designs. Device is in production to support existing customers, but TI does not recommend using this part in a new design.

**PREVIEW:** Device has been announced but is not in production. Samples may or may not be available.

**OBSELETE:** TI has discontinued the production of the device.

(2) Eco Plan - The planned eco-friendly classification: Pb-Free (RoHS), Pb-Free (RoHS Exempt), or Green (RoHS & no Sb/Br) - please check <http://www.ti.com/productcontent> for the latest availability information and additional product content details.

**TBD:** The Pb-Free/Green conversion plan has not been defined.

**Pb-Free (RoHS):** TI's terms "Lead-Free" or "Pb-Free" mean semiconductor products that are compatible with the current RoHS requirements for all 6 substances, including the requirement that lead not exceed 0.1% by weight in homogeneous materials. Where designed to be soldered at high temperatures, TI Pb-Free products are suitable for use in specified lead-free processes.

**Pb-Free (RoHS Exempt):** This component has a RoHS exemption for either 1) lead-based flip-chip solder bumps used between the die and package, or 2) lead-based die adhesive used between the die and leadframe. The component is otherwise considered Pb-Free (RoHS compatible) as defined above.

**Green (RoHS & no Sb/Br):** TI defines "Green" to mean Pb-Free (RoHS compatible), and free of Bromine (Br) and Antimony (Sb) based flame retardants (Br or Sb do not exceed 0.1% by weight in homogeneous material)

(3) MSL, Peak Temp. - The Moisture Sensitivity Level rating according to the JEDEC industry standard classifications, and peak solder temperature.

(4) There may be additional marking, which relates to the logo, the lot trace code information, or the environmental category on the device.

(5) Multiple Device Markings will be inside parentheses. Only one Device Marking contained in parentheses and separated by a "~" will appear on a device. If a line is indented then it is a continuation of the previous line and the two combined represent the entire Device Marking for that device.

(6) Lead/Ball Finish - Orderable Devices may have multiple material finish options. Finish options are separated by a vertical ruled line. Lead/Ball Finish values may wrap to two lines if the finish value exceeds the maximum column width.

**Important Information and Disclaimer:** The information provided on this page represents TI's knowledge and belief as of the date that it is provided. TI bases its knowledge and belief on information provided by third parties, and makes no representation or warranty as to the accuracy of such information. Efforts are underway to better integrate information from third parties. TI has taken and continues to take reasonable steps to provide representative and accurate information but may not have conducted destructive testing or chemical analysis on incoming materials and chemicals. TI and TI suppliers consider certain information to be proprietary, and thus CAS numbers and other limited information may not be available for release.

In no event shall TI's liability arising out of such information exceed the total purchase price of the TI part(s) at issue in this document sold by TI to Customer on an annual basis.

**OTHER QUALIFIED VERSIONS OF TS3USB221A-Q1 :**

- Catalog: [TS3USB221A](#)

## NOTE: Qualified Version Definitions:

- Catalog - TI's standard catalog product

**TAPE AND REEL INFORMATION**

**QUADRANT ASSIGNMENTS FOR PIN 1 ORIENTATION IN TAPE**

\*All dimensions are nominal

Device	Package Type	Package Drawing	Pins	SPQ	Reel Diameter (mm)	Reel Width W1 (mm)	A0 (mm)	B0 (mm)	K0 (mm)	P1 (mm)	W (mm)	Pin1 Quadrant
TS3USB221AQRSERQ1	UQFN	RSE	10	3000	180.0	8.4	1.68	2.13	0.76	4.0	8.0	Q1

TAPE AND REEL BOX DIMENSIONS



\*All dimensions are nominal

Device	Package Type	Package Drawing	Pins	SPQ	Length (mm)	Width (mm)	Height (mm)
TS3USB221AQRSERQ1	UQFN	RSE	10	3000	223.0	270.0	35.0

RSE (R-PUQFN-N10)

PLASTIC QUAD FLATPACK NO-LEAD

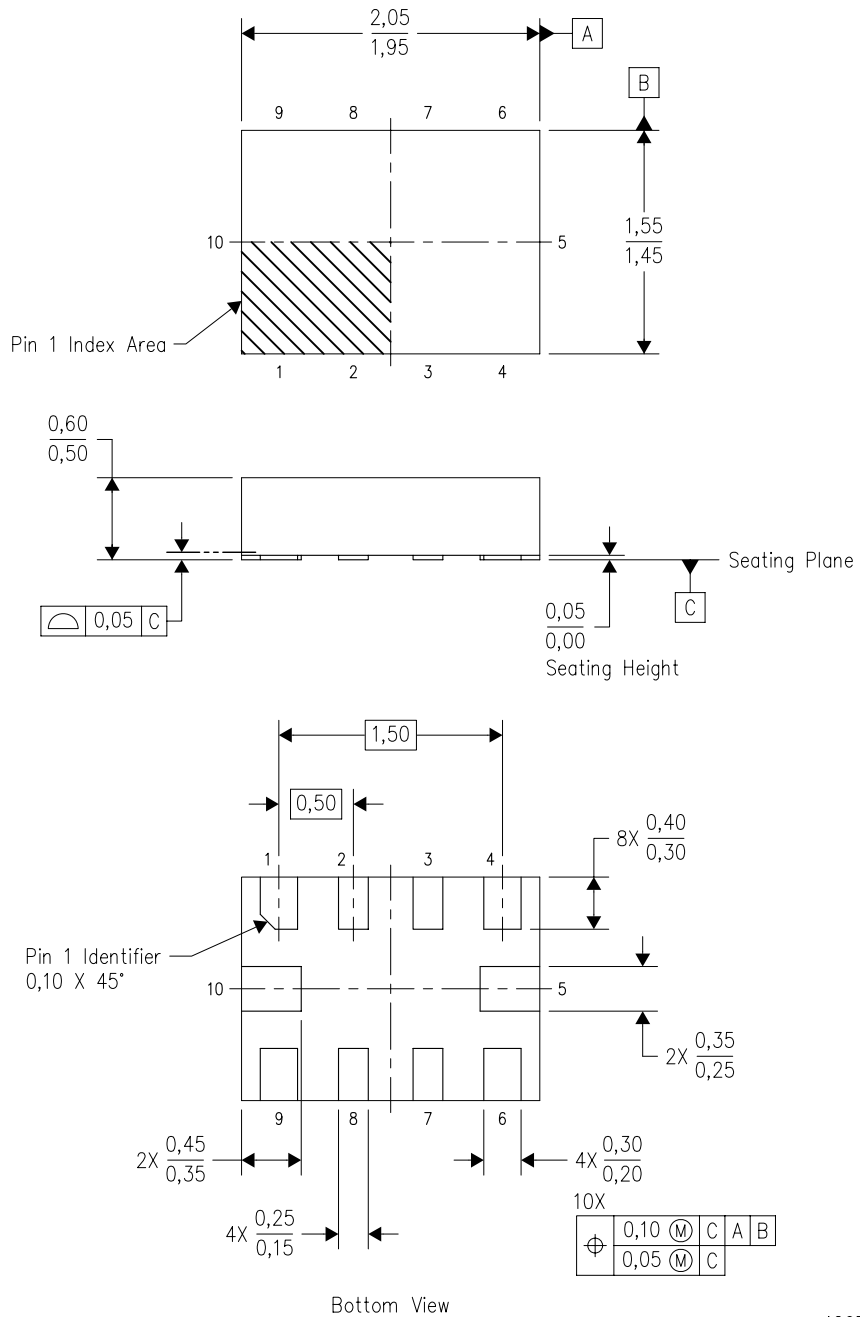

4207268-3/D 01/11

- NOTES:
- A. All linear dimensions are in millimeters. Dimensioning and tolerancing per ASME Y14.5M-1994.
  - B. This drawing is subject to change without notice.
  - C. QFN (Quad Flatpack No-Lead) package configuration.
  - D. This package complies to JEDEC MO-288 variation UDFD.

RSE (R-PUQFN-N10)

PLASTIC QUAD FLATPACK NO-LEAD

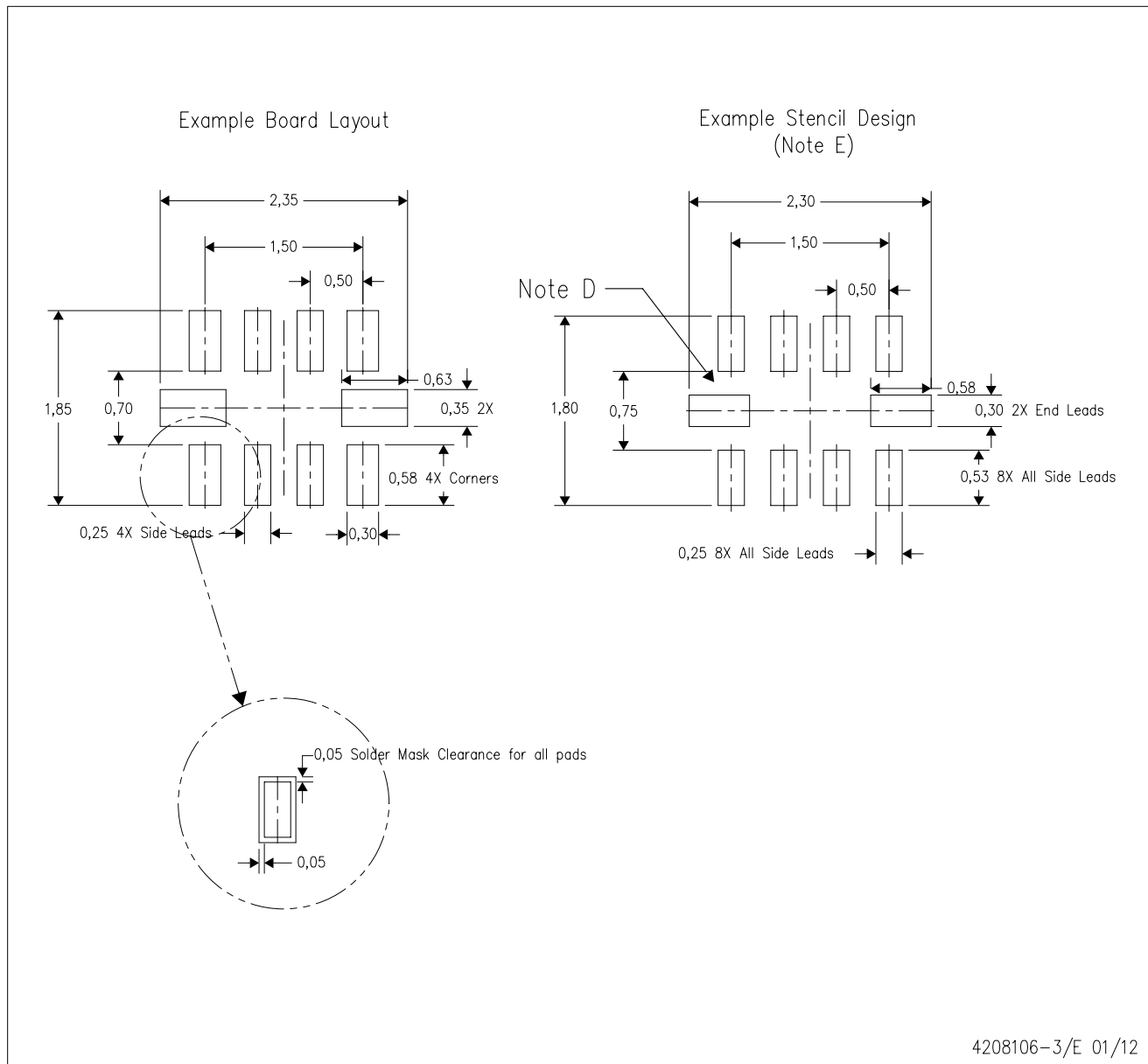

- NOTES:
- A. All linear dimensions are in millimeters.
  - B. This drawing is subject to change without notice.
  - C. Publication IPC-7351 is recommended for alternate designs.
  - D. Customers should contact their board fabrication site for minimum solder mask web tolerances between signal pads.
  - E. Maximum stencil thickness 0,127 mm (5 mils). All linear dimensions are in millimeters.
  - F. Laser cutting apertures with trapezoidal walls and also rounding corners will offer better paste release. Customers should contact their board assembly site for stencil design recommendations. Refer to IPC 7525 for stencil design considerations.
  - G. Side aperture dimensions over-print land for acceptable area ratio > 0.66. Customer may reduce side aperture dimensions if stencil manufacturing process allows for sufficient release at smaller opening.

## IMPORTANT NOTICE

Texas Instruments Incorporated and its subsidiaries (TI) reserve the right to make corrections, enhancements, improvements and other changes to its semiconductor products and services per JESD46, latest issue, and to discontinue any product or service per JESD48, latest issue. Buyers should obtain the latest relevant information before placing orders and should verify that such information is current and complete. All semiconductor products (also referred to herein as "components") are sold subject to TI's terms and conditions of sale supplied at the time of order acknowledgment.

TI warrants performance of its components to the specifications applicable at the time of sale, in accordance with the warranty in TI's terms and conditions of sale of semiconductor products. Testing and other quality control techniques are used to the extent TI deems necessary to support this warranty. Except where mandated by applicable law, testing of all parameters of each component is not necessarily performed.

TI assumes no liability for applications assistance or the design of Buyers' products. Buyers are responsible for their products and applications using TI components. To minimize the risks associated with Buyers' products and applications, Buyers should provide adequate design and operating safeguards.

TI does not warrant or represent that any license, either express or implied, is granted under any patent right, copyright, mask work right, or other intellectual property right relating to any combination, machine, or process in which TI components or services are used. Information published by TI regarding third-party products or services does not constitute a license to use such products or services or a warranty or endorsement thereof. Use of such information may require a license from a third party under the patents or other intellectual property of the third party, or a license from TI under the patents or other intellectual property of TI.

Reproduction of significant portions of TI information in TI data books or data sheets is permissible only if reproduction is without alteration and is accompanied by all associated warranties, conditions, limitations, and notices. TI is not responsible or liable for such altered documentation. Information of third parties may be subject to additional restrictions.

Resale of TI components or services with statements different from or beyond the parameters stated by TI for that component or service voids all express and any implied warranties for the associated TI component or service and is an unfair and deceptive business practice. TI is not responsible or liable for any such statements.

Buyer acknowledges and agrees that it is solely responsible for compliance with all legal, regulatory and safety-related requirements concerning its products, and any use of TI components in its applications, notwithstanding any applications-related information or support that may be provided by TI. Buyer represents and agrees that it has all the necessary expertise to create and implement safeguards which anticipate dangerous consequences of failures, monitor failures and their consequences, lessen the likelihood of failures that might cause harm and take appropriate remedial actions. Buyer will fully indemnify TI and its representatives against any damages arising out of the use of any TI components in safety-critical applications.

In some cases, TI components may be promoted specifically to facilitate safety-related applications. With such components, TI's goal is to help enable customers to design and create their own end-product solutions that meet applicable functional safety standards and requirements. Nonetheless, such components are subject to these terms.

No TI components are authorized for use in FDA Class III (or similar life-critical medical equipment) unless authorized officers of the parties have executed a special agreement specifically governing such use.

Only those TI components which TI has specifically designated as military grade or "enhanced plastic" are designed and intended for use in military/aerospace applications or environments. Buyer acknowledges and agrees that any military or aerospace use of TI components which have **not** been so designated is solely at the Buyer's risk, and that Buyer is solely responsible for compliance with all legal and regulatory requirements in connection with such use.

TI has specifically designated certain components as meeting ISO/TS16949 requirements, mainly for automotive use. In any case of use of non-designated products, TI will not be responsible for any failure to meet ISO/TS16949.

### Products

Audio	<a href="http://www.ti.com/audio">www.ti.com/audio</a>
Amplifiers	<a href="http://amplifier.ti.com">amplifier.ti.com</a>
Data Converters	<a href="http://dataconverter.ti.com">dataconverter.ti.com</a>
DLP® Products	<a href="http://www.dlp.com">www.dlp.com</a>
DSP	<a href="http://dsp.ti.com">dsp.ti.com</a>
Clocks and Timers	<a href="http://www.ti.com/clocks">www.ti.com/clocks</a>
Interface	<a href="http://interface.ti.com">interface.ti.com</a>
Logic	<a href="http://logic.ti.com">logic.ti.com</a>
Power Mgmt	<a href="http://power.ti.com">power.ti.com</a>
Microcontrollers	<a href="http://microcontroller.ti.com">microcontroller.ti.com</a>
RFID	<a href="http://www.ti-rfid.com">www.ti-rfid.com</a>
OMAP Applications Processors	<a href="http://www.ti.com/omap">www.ti.com/omap</a>
Wireless Connectivity	<a href="http://www.ti.com/wirelessconnectivity">www.ti.com/wirelessconnectivity</a>

### Applications

Automotive and Transportation	<a href="http://www.ti.com/automotive">www.ti.com/automotive</a>
Communications and Telecom	<a href="http://www.ti.com/communications">www.ti.com/communications</a>
Computers and Peripherals	<a href="http://www.ti.com/computers">www.ti.com/computers</a>
Consumer Electronics	<a href="http://www.ti.com/consumer-apps">www.ti.com/consumer-apps</a>
Energy and Lighting	<a href="http://www.ti.com/energy">www.ti.com/energy</a>
Industrial	<a href="http://www.ti.com/industrial">www.ti.com/industrial</a>
Medical	<a href="http://www.ti.com/medical">www.ti.com/medical</a>
Security	<a href="http://www.ti.com/security">www.ti.com/security</a>
Space, Avionics and Defense	<a href="http://www.ti.com/space-avionics-defense">www.ti.com/space-avionics-defense</a>
Video and Imaging	<a href="http://www.ti.com/video">www.ti.com/video</a>

### TI E2E Community

[e2e.ti.com](http://e2e.ti.com)