

2-Gbps DIFFERENTIAL SWITCH 8-Bit, 1:2 MULTIPLEXER/DEMULTIPLEXER WITH 3-SIDE BAND SIGNALS

Check for Samples: [TS3DV20812](#)

FEATURES

- Four High-Speed Bidirectional Differential Pair Channel MUX/DEMUX
- Supports up to 2 Gbps Data Rate
- V_{DD} Operating Range 2.5 V or 3.3
 - -0 V to 3.3 V Rail To Rail at 2.5 V
 - -0 V to 5 V Rail To Rail at 3.3V
- I_{OFF} partial Powerdown and Back-Drive Protection.
- 5-V Input Tolerant on Control Pin
- Supports Both AC- and DC-Coupled Signals
- Low Crosstalk: -38 dB at 825 MHz, 2.5 V or 3.3 V
- Insertion Loss: -1.5 dB at 825 MHz, 2.5 V or 3.3 V
- Off Isolation -24.67 dB at 825 MHz
- Low Bit-to-Bit Skew within Pair 5 ps Maximum
- Channel-to-Channel Skew: 30 ps Maximum
- Propagation Delay Times: 250 ps Maximum
- ESD Performance Tested per JESD 22
 - 2000-V Human Body Model (A114-B, Class II)
 - 1000-V Charged-Device Model (C101)

APPLICATIONS

- HDMI/DVI Video MUX
- Panel LVDS Bus MUX
- LVDS, LVPECL, CML
- Analog Signals VGA
- Gigabit LAN Signal MUX
- Serial Backplane Signal MUX
- Optical Module
- Central Office Telecommunication
- Wireless Base Station
- High-Speed Logic Data I/O MUX

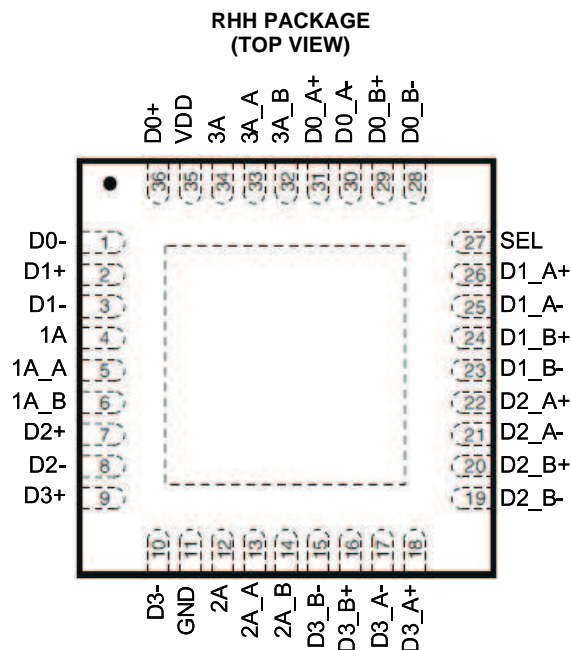

DESCRIPTION/ORDERING INFORMATION

TS3DV20812 is a High Speed Data Rate up to 2Gbps for Differential Signal Passive bi-directional Multiplexer and De-multiplexer for I/O rails up to 5V Level with Low Crosstalk and Insertion Loss.

TS3DV20812 can be used in either HDMI/DVI sink side or source side with 4-differential pair supporting the high speed and control pins.

The I_{off} and back drive protection allowing to connect the external cable and prevent the back flow current when the V_{cc} is into 0V.

The 3 side band signals can be used in DDC (SDAL, SCL) and CEC Signal MUX.

TS3DS20812 is characterized for operation from -40C to 85C.



Please be aware that an important notice concerning availability, standard warranty, and use in critical applications of Texas Instruments semiconductor products and disclaimers thereto appears at the end of this data sheet.

Table 1. ORDERING INFORMATION

T _A	PACKAGE ⁽¹⁾ (2)		ORDERABLE PART NUMBER	TOP-SIDE MARKING
-40°C to 85°C	QFN – RHH	Tape and reel	TS3DV20812RHH	TBD

- (1) Package drawings, thermal data, and symbolization are available at www.ti.com/packaging.
- (2) For the most current package and ordering information, see the Package Option Addendum at the end of this document, or see the TI website at www.ti.com.

LOGIC DIAGRAM

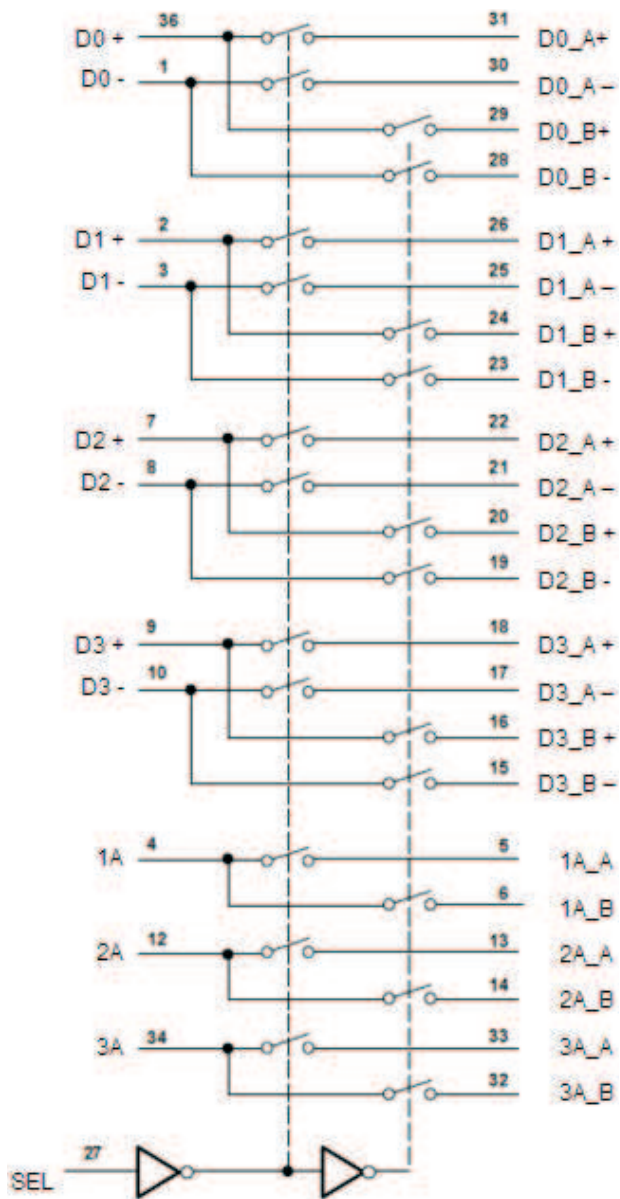

FUNCTION TABLE

INPUT SEL	DIFFERENTIAL SIGNAL I/Os	FUNCTIONS	
		A-PORT	B-PORT
L	Dn (±), nA (AUX (±), HPD, CAD/CEC)	DnA (±), nA_A	High-impedance mode
H		High-impedance mode	DnB (±), nA_B

ABSOLUTE MAXIMUM RATINGS⁽¹⁾

over operating free-air temperature range (unless otherwise noted)

			MIN	MAX	UNIT
V _{DD}	Supply voltage range		-0.5	4.6	V
V _{IN}	Control input voltage range ⁽²⁾⁽³⁾	SEL	-0.5	7	V
		I/O	-0.5	7	V
V _{IO}	Switch I/O voltage range (all three I/O ports) ⁽⁴⁾	D0-D3, Aux, HPD, CAD/CEC	-0.5	V _{CC} + 0.5	V
		A port and B port	-0.5	V _{CC} + 0.5	V
I _{IK}	Control input clamp current	V _{IN} < 0		-50	mA
I _{I/O} K	I/O port clamp current	V _O < 0		-50	mA
I _{IO}	Continuous output current ⁽⁵⁾	ON-state switch		±128	mA
			Continuous current through VDD or GND		±100
Θ _{JA}	Package thermal impedance ⁽⁶⁾	RHH package		31.8	°C/W
T _{stg}	Storage temperature range		-65	150	°C

- (1) Stresses beyond those listed under "absolute maximum ratings" may cause permanent damage to the device. These are stress ratings only, and functional operation of the device at these or any other conditions beyond those indicated under "recommended operating conditions" is not implied. Exposure to absolute-maximum-rated conditions for extended periods may affect device reliability.
- (2) All voltages are with respect to ground, unless otherwise specified.
- (3) The input and output voltage ratings may be exceeded if the input and output clamp-current ratings are observed.
- (4) V_I and V_O are used to denote specific conditions for V_{IO}.
- (5) I_I and I_O are used to denote specific conditions for I_{IO}.
- (6) The package thermal impedance is calculated in accordance with JESD 51-7.

RECOMMENDED OPERATING CONDITIONS

			MIN	MAX	UNIT
V _{DD}	Supply voltage		2.25	3.6	V
V _{IH}	High-level control input voltage	SEL	2	5.5	V
V _{IL}	Low-level control input voltage	SEL	0	0.8	V
V _{I/O}	Input/output voltage	All ports	0	5.5	V
V _{ANALOG}	Analog signal range	Differential signal range	0	V _{DD}	V
V _I	Input tolerant	SEL	0	5.5	V
T _A	Operating free-air temperature		-40	85	°C

ELECTRICAL CHARACTERISTICS

for high-frequency switching over recommended operating free-air temperature range $V_{DD} = 3.3 \text{ V} \pm 0.3 \text{ V}$ (unless otherwise noted)

PARAMETER		TEST CONDITIONS ⁽¹⁾		MIN	TYP ⁽²⁾	MAX	UNIT
V_{IK}	SEL	$V_{DD} = 3.6 \text{ V}$,	$I_{IN} = -18 \text{ mA}$		-0.7	-1.2	V
I_{IH}	SEL	$V_{DD} = 3.6 \text{ V}$,	$V_{IN} = V_{DD}$			± 1	μA
I_{IL}	SEL	$V_{DD} = 3.6 \text{ V}$,	$V_{IN} = \text{GND}$			± 1	μA
I_{OFF}		$V_{DD} = 06 \text{ V}$,	$V_O = 0 \text{ to } 3.6 \text{ V}$, $V_I = 0$, $V_{IN} = 0$			1	μA
I_{CC}		$V_{DD} = 3.6 \text{ V}$,	$I_{IO} = 0$		250	500	μA
C_{IN}	SEL	$f = 10 \text{ MHz}$,	$V_{IN} = 0$		2	2.5	pF
C_{OFF}	3-Port	$f = 10 \text{ MHz}$,	$V_{IN} = 0$, Output is Open, Switch is OFF		2.5	4	pF
C_{ON}	3-Port	$f = 10 \text{ MHz}$,	$V_{IN} = 0$, Output is Open, Switch is ON		8		pF
r_{ON}		$V_{DD} = 3.6 \text{ V}$	$1.5 \text{ V} \leq V_I \leq V_{DD}$, $I_O = -40 \text{ mA}$		4	6	Ω
$r_{ON(\text{flat})}$ ⁽³⁾		$V_{DD} = 3.6 \text{ V}$	$1.5 \text{ V} \leq V_I \leq V_{DD}$, $I_O = -40 \text{ mA}$		0.5		Ω
Δr_{ON} ⁽⁴⁾		$V_{DD} = 3.6 \text{ V}$	$1.5 \text{ V} \leq V_I \leq V_{DD}$, $I_O = -40 \text{ mA}$		0.4	1	Ω

- (1) V_I , V_O , I_I , and I_O refer to I/O pins, V_{IN} refers to the control inputs.
(2) All typical values are at $V_{DD} = 3.3 \text{ V}$ (unless otherwise noted), $T_A = 25^\circ$.
(3) $r_{ON(\text{flat})}$ is the difference of r_{ON} in a given channel at specified voltages.
(4) Δr_{ON} is the difference of r_{ON} from center (D0 to Dn) ports to any other port.

ELECTRICAL CHARACTERISTICS

for high-frequency switching over recommended operating free-air temperature range $V_{DD} = 2.5 \text{ V} \pm 0.25 \text{ V}$ (unless otherwise noted)

PARAMETER		TEST CONDITIONS ⁽¹⁾		MIN	TYP ⁽²⁾	MAX	UNIT
V_{IK}	SEL	$V_{DD} = 2.5 \text{ V}$,	$I_{IN} = -18 \text{ mA}$		-0.7	-1.2	V
I_{IH}	SEL	$V_{DD} = 2.5 \text{ V}$,	$V_{IN} = V_{DD}$			± 1	μA
I_{IL}	SEL	$V_{DD} = 2.5 \text{ V}$,	$V_{IN} = \text{GND}$			± 1	μA
I_{OFF}		$V_{DD} = 06 \text{ V}$,	$V_O = 0 \text{ to } 2.5 \text{ V}$, $V_I = 0$, $V_{IN} = 0$			1	μA
I_{CC}		$V_{DD} = 2.5 \text{ V}$,	$I_{IO} = 0$		250	500	μA
C_{IN}	SEL	$f = 10 \text{ MHz}$,	$V_{IN} = 0$		2	2.5	pF
C_{OFF}	3-Port	$f = 10 \text{ MHz}$,	$V_{IN} = 0$, Output is Open, Switch is OFF		2.5	4	pF
C_{ON}	3-Port	$f = 10 \text{ MHz}$,	$V_{IN} = 0$, Output is Open, Switch is ON		8		pF
r_{ON}		$V_{DD} = 2.5 \text{ V}$	$1.5 \text{ V} \leq V_I \leq V_{DD}$, $I_O = -40 \text{ mA}$		4	6	Ω
$r_{ON(\text{flat})}$ ⁽³⁾		$V_{DD} = 2.5 \text{ V}$	$V_I = 1.5 \text{ V}$ and V_{DD} , $I_O = -40 \text{ mA}$		0.5		Ω
Δr_{ON} ⁽⁴⁾		$V_{DD} = 2.5 \text{ V}$	$1.5 \text{ V} \leq V_I \leq V_{DD}$, $I_O = -40 \text{ mA}$		0.4	1	Ω

- (1) V_I , V_O , I_I , and I_O refer to I/O pins, V_{IN} refers to the control inputs.
(2) All typical values are at $V_{DD} = 2.5 \text{ V}$ (unless otherwise noted), $T_A = 25^\circ$.
(3) $r_{ON(\text{flat})}$ is the difference of r_{ON} in a given channel at specified voltages.
(4) Δr_{ON} is the difference of r_{ON} from center (D0 to Dn) ports to any other port.

SWITCHING CHARACTERISTICS

over recommended operating free-air temperature range, $V_{DD} = 3.3\text{ V} \pm 0.3\text{ V}$, $R_L = 200\ \Omega$, $C_L = 10\text{ pF}$ (unless otherwise noted) (see [Figure 9](#) and [Figure 10](#))

PARAMETER	FROM (INPUT)	TO (OUTPUT)	MIN	TYP ⁽¹⁾	MAX	UNIT
$t_{pd}^{(2)}$	Dn	D _A or D _B		149		ps
t_{pZH} , t_{pZL}	SEL	D _A or D _B	0.5		15	ns
t_{pHZ} , t_{pLZ}	SEL	D _A or D _B	0.9		12	ns
SEL to switch turn on time		D _A or D _B		9	14	ns
SEL to switch turn off time		D _A or D _B		5	11	ns
$t_{sk(o)}^{(3)}$	Dn (+)(-), DA(+)(-), DB(+)(-)			22	28	ps
$t_{sk(o)}$	Dn (all), DnA(all), DnB(All)			19	25	ps
$t_{sk(p)}^{(4)}$				22	31	ps

(1) All typical values are at $V_{DD} = 2.5\text{ V}$ (unless otherwise noted), $T_A = 25^\circ$.

(2) The propagation delay is the calculated RC time constant of the typical ON-State resistance of the switch and the specified load capacitance when driven by an ideal voltage source (zero output impedance).

(3) Output skew between center port to any other port.

(4) Skew between opposite transitions of the same output in a given device $|t_{pHL} - t_{pLH}|$

SWITCHING CHARACTERISTICS

over recommended operating free-air temperature range, $V_{DD} = 2.5\text{ V} \pm 0.25\text{ V}$, $R_L = 200\ \Omega$, $C_L = 10\text{ pF}$ (unless otherwise noted) (see [Figure 9](#) and [Figure 10](#))

PARAMETER	FROM (INPUT)	TO (OUTPUT)	MIN	TYP ⁽¹⁾	MAX	UNIT
$t_{pd}^{(2)}$	Dn	D _A or D _B		149		ps
t_{pZH} , t_{pZL}	SEL	D _A or D _B	0.5		14	ns
t_{pHZ} , t_{pLZ}	SEL	D _A or D _B	0.9		15	ns
SEL to switch turn on time		D _A or D _B		9	17	ns
SEL to switch turn off time	D _A or D _B	D _A or D _B		5	18	ns
$t_{sk(o)}^{(3)}$	Dn (+)(-), DA(+)(-), DB(+)(-)			22	31	ps
$t_{sk(o)}$	Dn (all), DnA(all), DnB(All)			19	23	ps
$t_{sk(p)}^{(4)}$				22	33	ps

(1) All typical values are at $V_{DD} = 2.5\text{ V}$ (unless otherwise noted), $T_A = 25^\circ$.

(2) The propagation delay is the calculated RC time constant of the typical ON-State resistance of the switch and the specified load capacitance when driven by an ideal voltage source (zero output impedance).

(3) Output skew between center port to any other port.

(4) Skew between opposite transitions of the same output in a given device $|t_{pHL} - t_{pLH}|$

DYNAMIC CHARACTERISTICS

over recommended operating free-air temperature range, $V_{DD} = 3.3 \text{ V} \pm 0.3 \text{ V}$, $R_L = 50 \ \Omega$, $C_L = 10 \text{ pF}$ (unless otherwise noted)

PARAMETER		TEST CONDITIONS	TYP	UNIT
X_{TALK}	Differential crosstalk	825 MHz, 1.65Gbps, $R_L = 50 \ \Omega$, $C_L = 10 \text{ pF}$, see Figure 11	-34.67	dB
O_{IRR}	Differential OFF isolation	825 MHz, 1.65Gbps, $R_L = 50 \ \Omega$, $C_L = 10 \text{ pF}$, see Figure 12	-19.09	dB
I_{LOSS}	Differential insertion loss	825 MHz, 1.65Gbps, $R_L = 50 \ \Omega$, $C_L = 10 \text{ pF}$, see Figure 13	-2.84	dB
I_{RETURN}	Differential return loss	825 MHz, 1.65Gbps, $R_L = 50 \ \Omega$, $C_L = 10 \text{ pF}$, see Figure 13	-9.43	dB
DR	Data rate		2.20	Gbps
BW	Differential bandwidth		1.10	Ghz

DYNAMIC CHARACTERISTICS

over recommended operating free-air temperature range, $V_{DD} = 2.5 \text{ V} \pm 0.25 \text{ V}$, $R_L = 50 \ \Omega$, $C_L = 10 \text{ pF}$ (unless otherwise noted)

PARAMETER		TEST CONDITIONS	TYP	UNIT
X_{TALK}	Differential crosstalk	825 MHz, 1.65Gbps, $R_L = 50 \ \Omega$, $C_L = 10 \text{ pF}$, see Figure 7	-34.94	dB
O_{IRR}	Differential OFF isolation	825 MHz, 1.65Gbps, $R_L = 50 \ \Omega$, $C_L = 10 \text{ pF}$, see Figure 8	-18.39	dB
I_{LOSS}	Differential insertion loss	825 MHz, 1.65Gbps, $R_L = 50 \ \Omega$, $C_L = 10 \text{ pF}$, see Figure 9	-3.07	dB
I_{RETURN}	Differential return loss	825 MHz, 1.65Gbps, $R_L = 50 \ \Omega$, $C_L = 10 \text{ pF}$, see Figure 9	-9.56	dB
DR	Data rate		2.20	Gbps
BW	Differential bandwidth		1.10	Ghz

TYPICAL PERFORMANCE

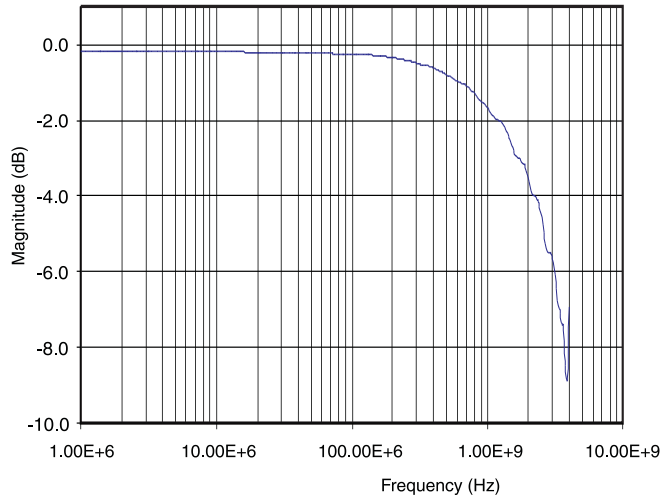

Figure 1. Differential Gain vs Frequency

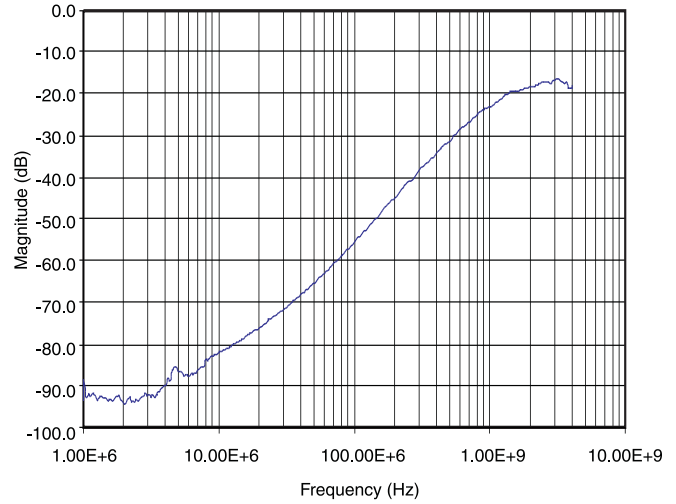

Figure 2. Differential Off Isolation vs Frequency

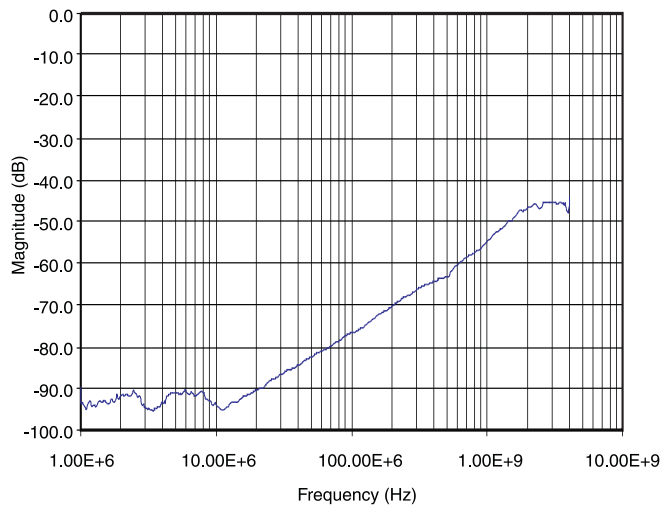

Figure 3. Differential Crosstalk vs Frequency

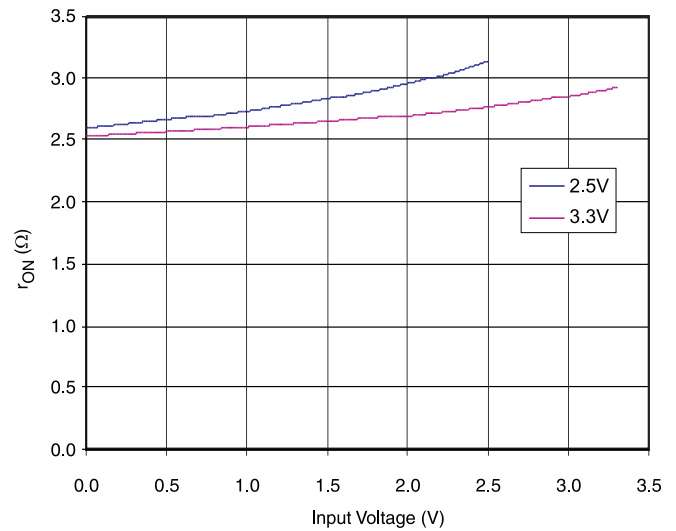

Figure 4. r_{ON} vs V_{COM} (Differential Switch)

APPLICATION INFORMATION

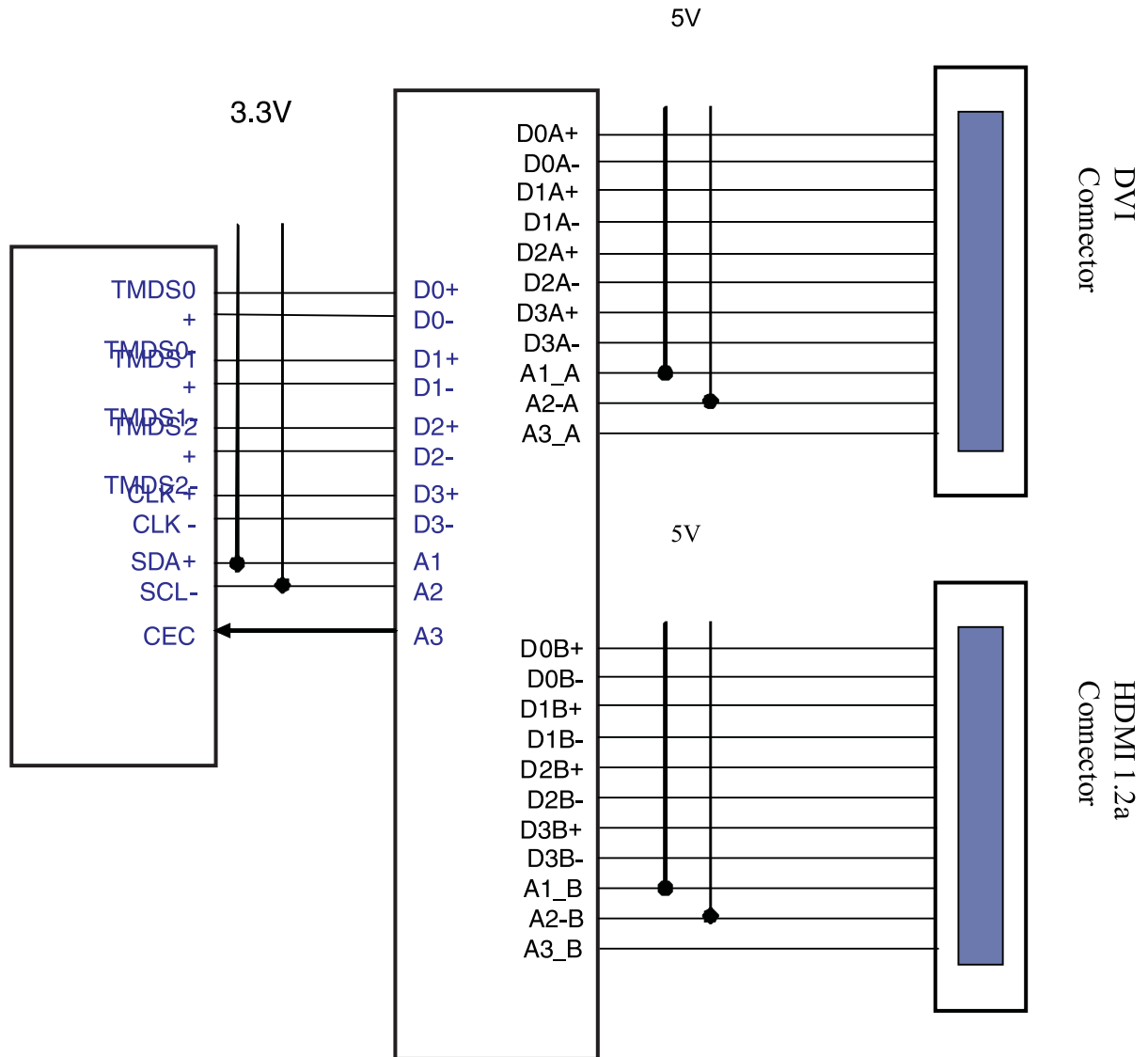

Figure 5. Typical Application Switching HDMI 1.2a and DVI

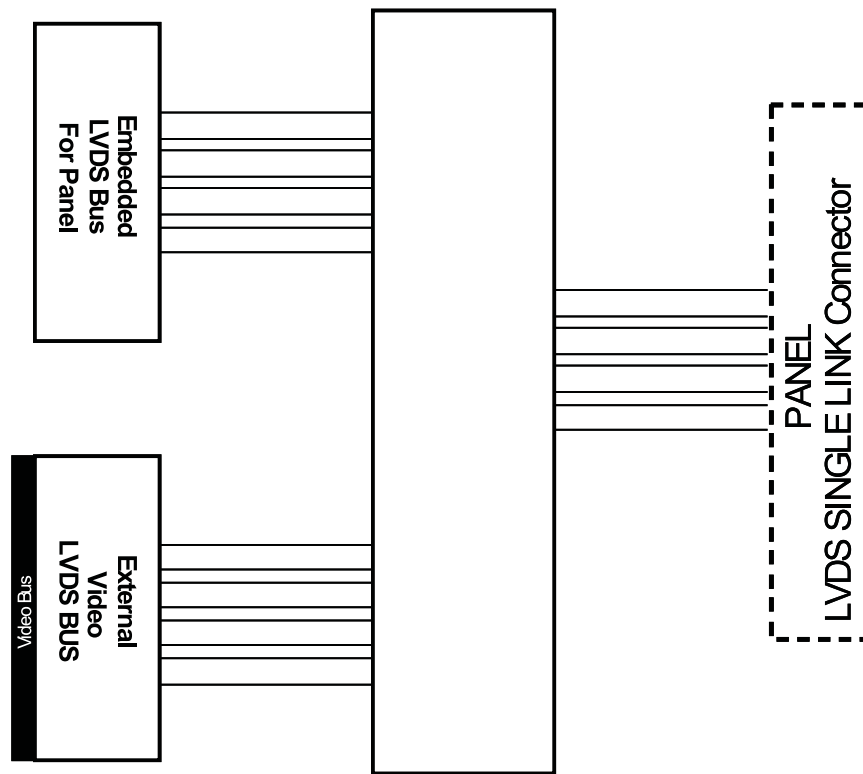
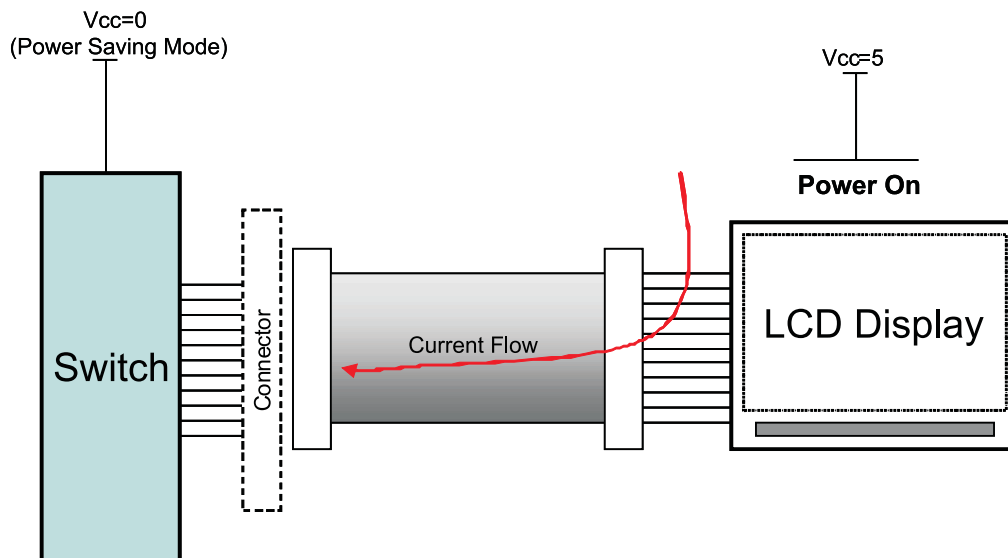

Figure 6. Typical Application for Dual LVDS



- A. The switch already has I_{OFF} circuit and it will reduce the current flow leakage limit to 10 μA maximum and it will prevent the damage from back drive current flow from the power-on circuit.

Figure 7. I_{OFF} (Back Drive Protection)

PARAMETER MEASUREMENT INFORMATION

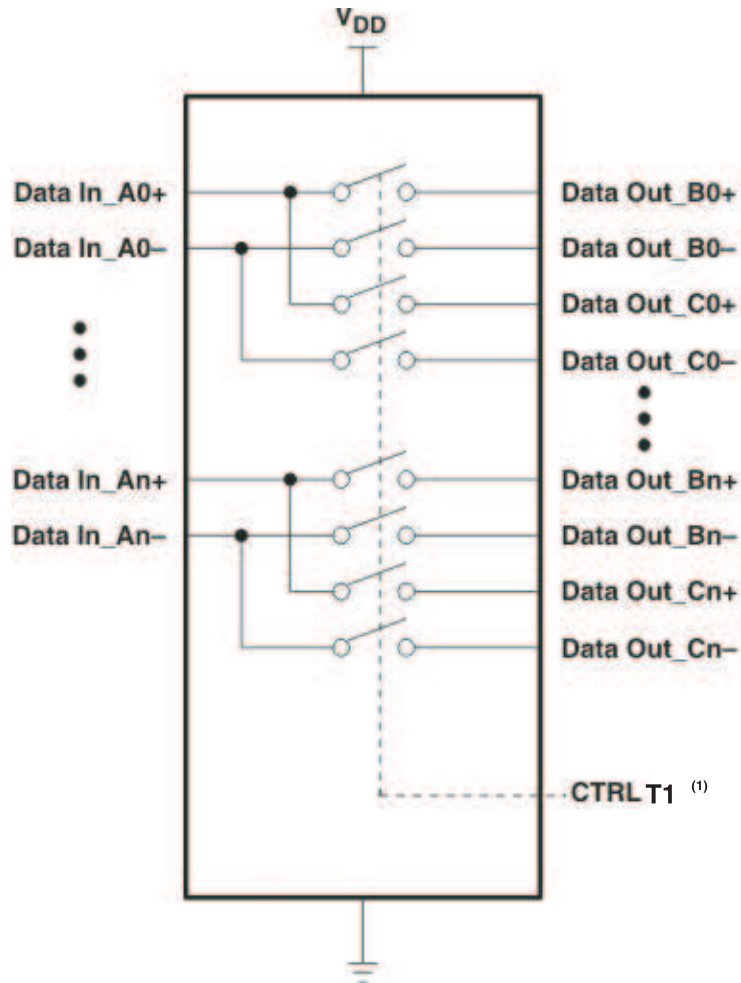

TEST PATH	T1 ⁽¹⁾
Data In_An=Data Out_Bn	GND
Data In_An=Data Out_Cn	V _{DD}

(1) T1 is an external terminal.

Figure 8. Differential Signaling Device

PARAMETER MEASUREMENT INFORMATION (continued)

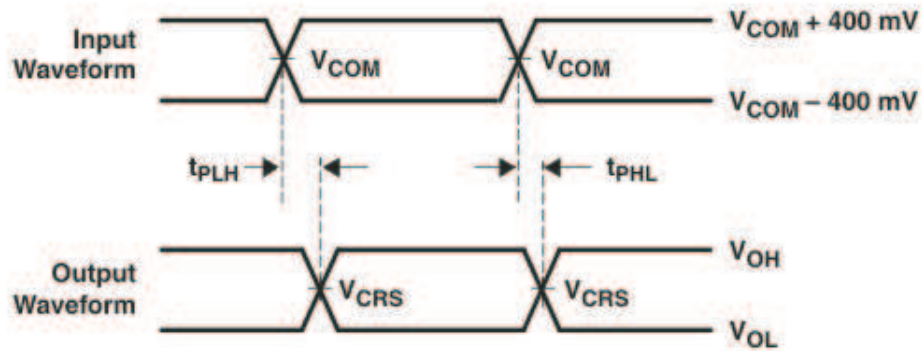
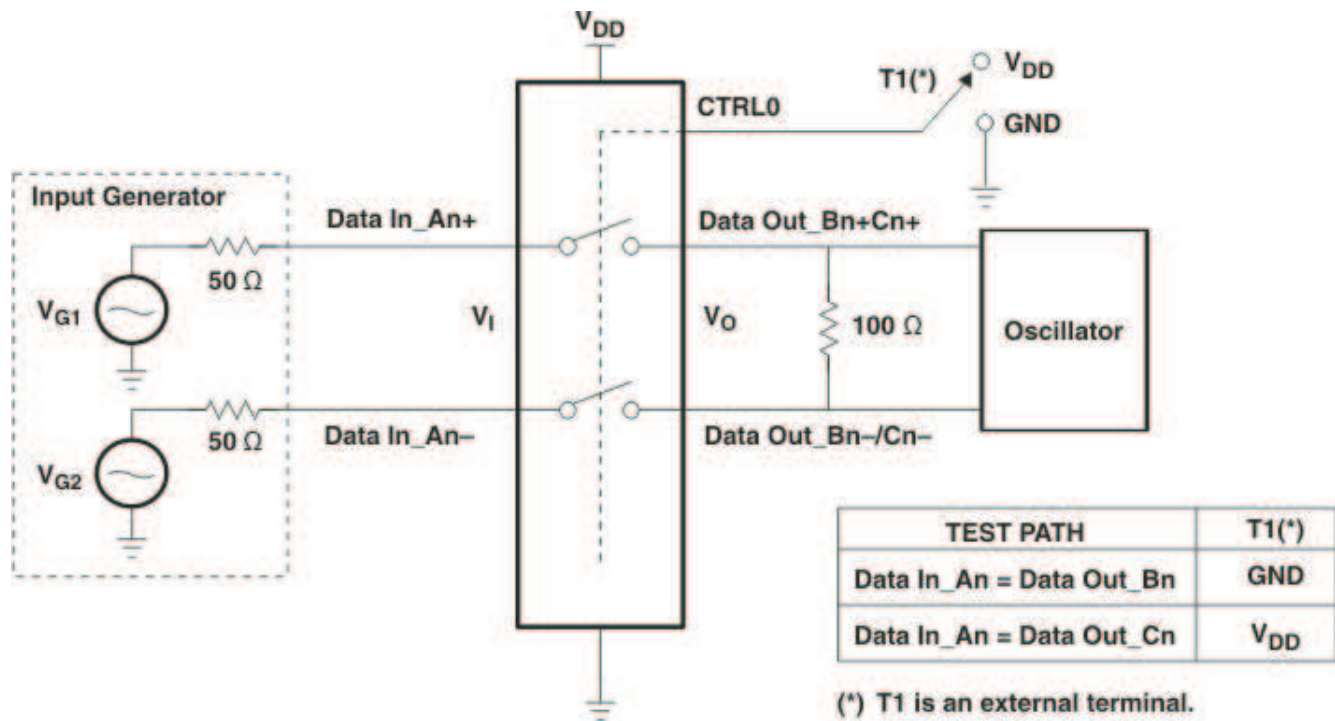

$$V_{COM} = 1.5\text{ V}$$

V_{CRS} is the cross-point of the differential signal.

$$t_{sk} = |t_{PLHn} - t_{PHLn}|$$

Figure 9. Test Circuit for Propagation Delay and Intra-Pair Skew

PARAMETER MEASUREMENT INFORMATION (continued)

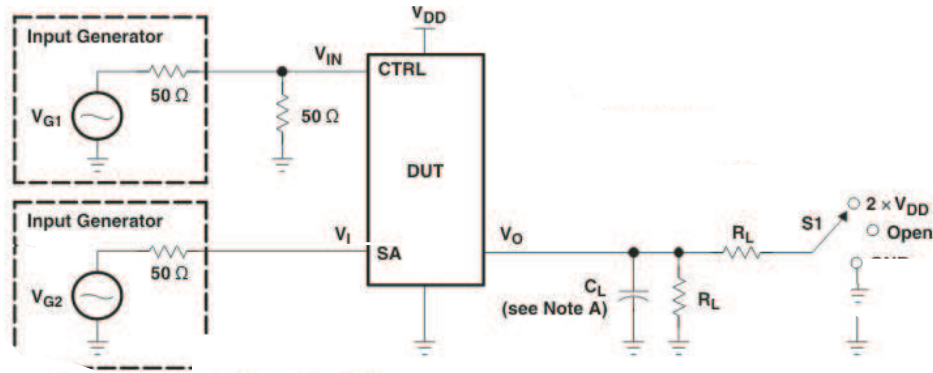

TEST	V _{DD}	S1	R _L	V _I	C _L	V _Δ
t _{PLZ} /t _{PZL}	3.3 V ±300 mV	2 × V _{DD}	100 Ω	GND	No load	0.3 V
t _{PZH} /t _{PZH}	3.3 V ±300 mV	GND	100 Ω	V _{DD}	No load	0.3 V

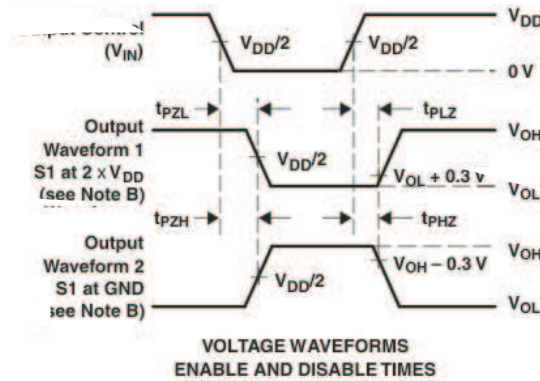

- A. CL includes probe and jig capacitance.
- B. Waveform 1 is for an output with internal conditions such that the output is low, except when disabled by the output control. Waveform 2 is for an output with internal conditions such that the output is high, except when disabled by the output control.
- C. All input pulses are supplied by generators having the following characteristics: PRR ≤ 10 MHz, ZO = 50 ohm, tr ≤ 2.5 ns, tf ≤ 2.5 ns
- D. The outputs are measured one at a time, with one transition per measurement.
- E. t_{PLZ} and t_{PHZ} are the same as t_{dis}.
- F. t_{PZL} and t_{PZH} are the same as t_{en}.

Figure 10. Test Circuit and Voltage Waveforms

PARAMETER MEASUREMENT INFORMATION (continued)

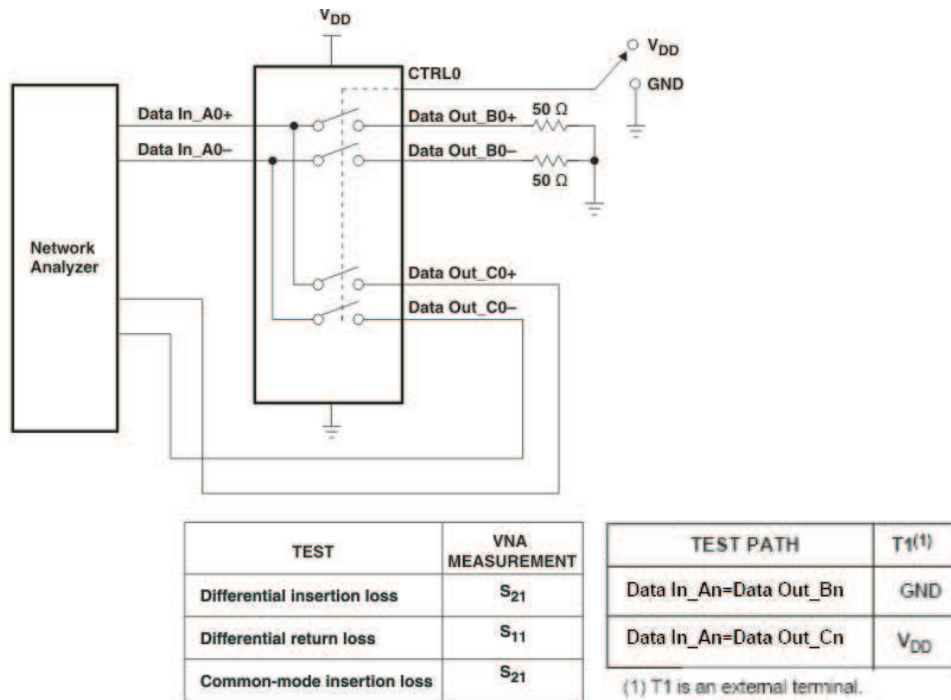
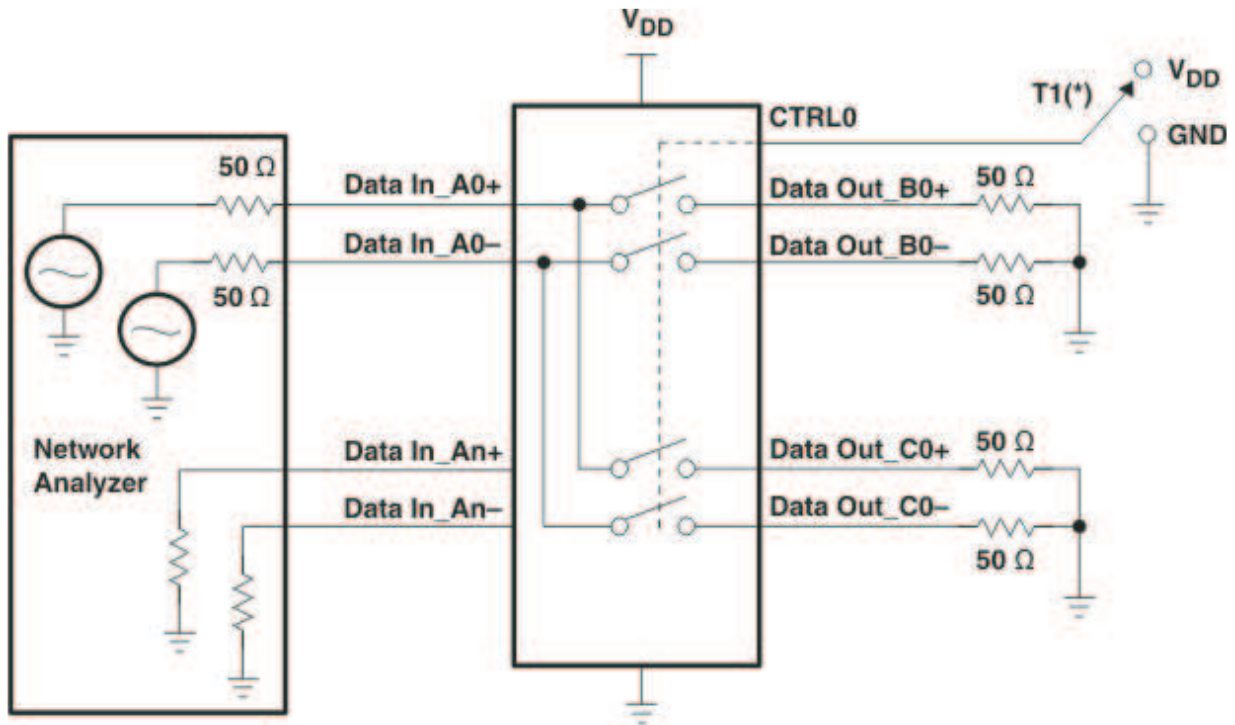

Figure 11. Differential Crosstalk Test Circuit

PARAMETER MEASUREMENT INFORMATION (continued)



(*) T1 is an external terminal.

TEST PATH	T1 ⁽¹⁾
Data In_An=Data Out_Bn	GND
Data In_An=Data Out_Cn	V _{DD}

(1) T1 is an external terminal.

Figure 12. Differential OFF Isolation Test Circuit

PARAMETER MEASUREMENT INFORMATION (continued)

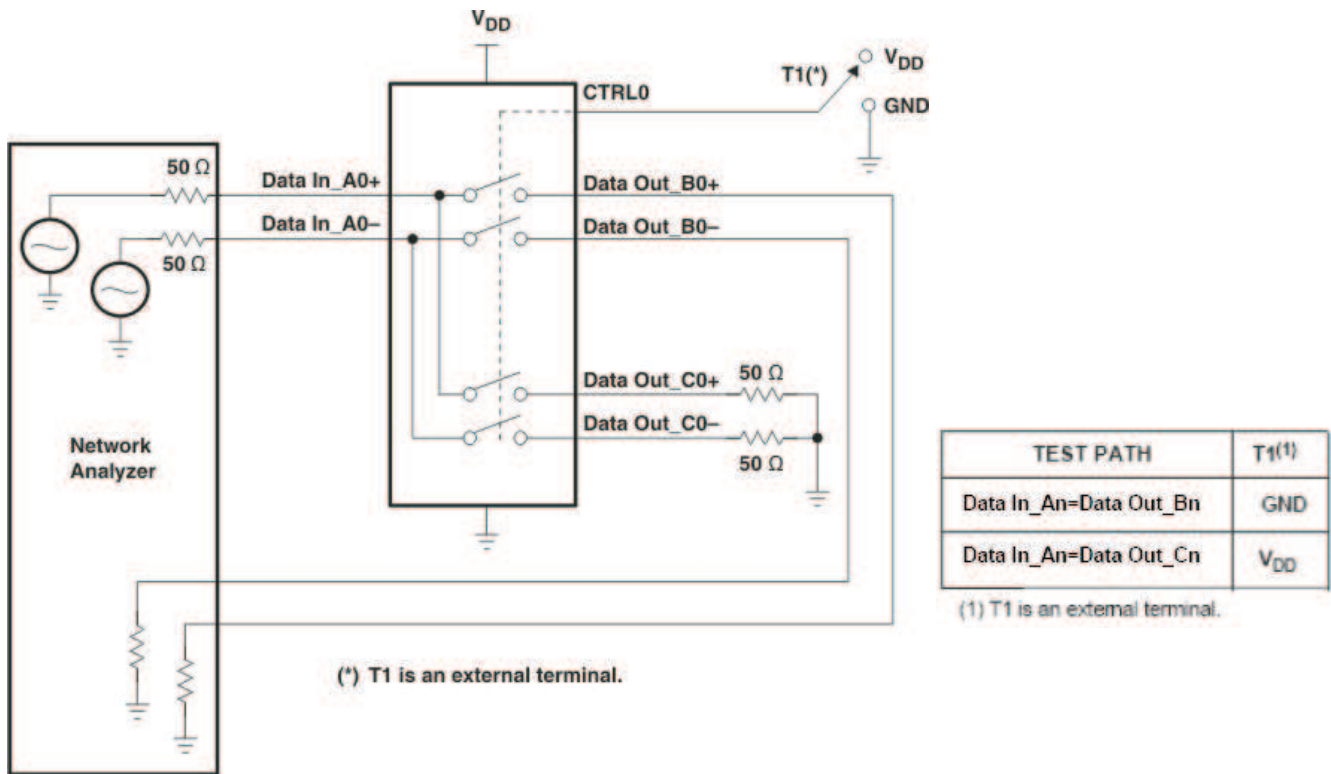

Figure 13. Differential Insertion Loss, Return Loss, and Common-Mode Insertion Loss Test Circuit

PACKAGING INFORMATION

Orderable Device	Status (1)	Package Type	Package Drawing	Pins	Package Qty	Eco Plan (2)	Lead/Ball Finish	MSL Peak Temp (3)	Op Temp (°C)	Device Marking (4/5)	Samples
TS3DV20812RHHR	ACTIVE	VQFN	RHH	36	2500	Green (RoHS & no Sb/Br)	CU NIPDAU	Level-3-260C-168 HR	-40 to 85	SY812	Samples

(1) The marketing status values are defined as follows:

ACTIVE: Product device recommended for new designs.

LIFEBUY: TI has announced that the device will be discontinued, and a lifetime-buy period is in effect.

NRND: Not recommended for new designs. Device is in production to support existing customers, but TI does not recommend using this part in a new design.

PREVIEW: Device has been announced but is not in production. Samples may or may not be available.

OBSOLETE: TI has discontinued the production of the device.

(2) Eco Plan - The planned eco-friendly classification: Pb-Free (RoHS), Pb-Free (RoHS Exempt), or Green (RoHS & no Sb/Br) - please check <http://www.ti.com/productcontent> for the latest availability information and additional product content details.

TBD: The Pb-Free/Green conversion plan has not been defined.

Pb-Free (RoHS): TI's terms "Lead-Free" or "Pb-Free" mean semiconductor products that are compatible with the current RoHS requirements for all 6 substances, including the requirement that lead not exceed 0.1% by weight in homogeneous materials. Where designed to be soldered at high temperatures, TI Pb-Free products are suitable for use in specified lead-free processes.

Pb-Free (RoHS Exempt): This component has a RoHS exemption for either 1) lead-based flip-chip solder bumps used between the die and package, or 2) lead-based die adhesive used between the die and leadframe. The component is otherwise considered Pb-Free (RoHS compatible) as defined above.

Green (RoHS & no Sb/Br): TI defines "Green" to mean Pb-Free (RoHS compatible), and free of Bromine (Br) and Antimony (Sb) based flame retardants (Br or Sb do not exceed 0.1% by weight in homogeneous material)

(3) MSL, Peak Temp. -- The Moisture Sensitivity Level rating according to the JEDEC industry standard classifications, and peak solder temperature.

(4) There may be additional marking, which relates to the logo, the lot trace code information, or the environmental category on the device.

(5) Multiple Device Markings will be inside parentheses. Only one Device Marking contained in parentheses and separated by a "~" will appear on a device. If a line is indented then it is a continuation of the previous line and the two combined represent the entire Device Marking for that device.

Important Information and Disclaimer: The information provided on this page represents TI's knowledge and belief as of the date that it is provided. TI bases its knowledge and belief on information provided by third parties, and makes no representation or warranty as to the accuracy of such information. Efforts are underway to better integrate information from third parties. TI has taken and continues to take reasonable steps to provide representative and accurate information but may not have conducted destructive testing or chemical analysis on incoming materials and chemicals. TI and TI suppliers consider certain information to be proprietary, and thus CAS numbers and other limited information may not be available for release.

In no event shall TI's liability arising out of such information exceed the total purchase price of the TI part(s) at issue in this document sold by TI to Customer on an annual basis.

TAPE AND REEL INFORMATION

QUADRANT ASSIGNMENTS FOR PIN 1 ORIENTATION IN TAPE

*All dimensions are nominal

Device	Package Type	Package Drawing	Pins	SPQ	Reel Diameter (mm)	Reel Width W1 (mm)	A0 (mm)	B0 (mm)	K0 (mm)	P1 (mm)	W (mm)	Pin1 Quadrant
TS3DV20812RHHR	VQFN	RHH	36	2500	330.0	16.4	6.3	6.3	1.1	12.0	16.0	Q2

TAPE AND REEL BOX DIMENSIONS



*All dimensions are nominal

Device	Package Type	Package Drawing	Pins	SPQ	Length (mm)	Width (mm)	Height (mm)
TS3DV20812RHHR	VQFN	RHH	36	2500	367.0	367.0	38.0

MECHANICAL DATA

RHH (S-PVQFN-N36)

PLASTIC QUAD FLATPACK NO-LEAD

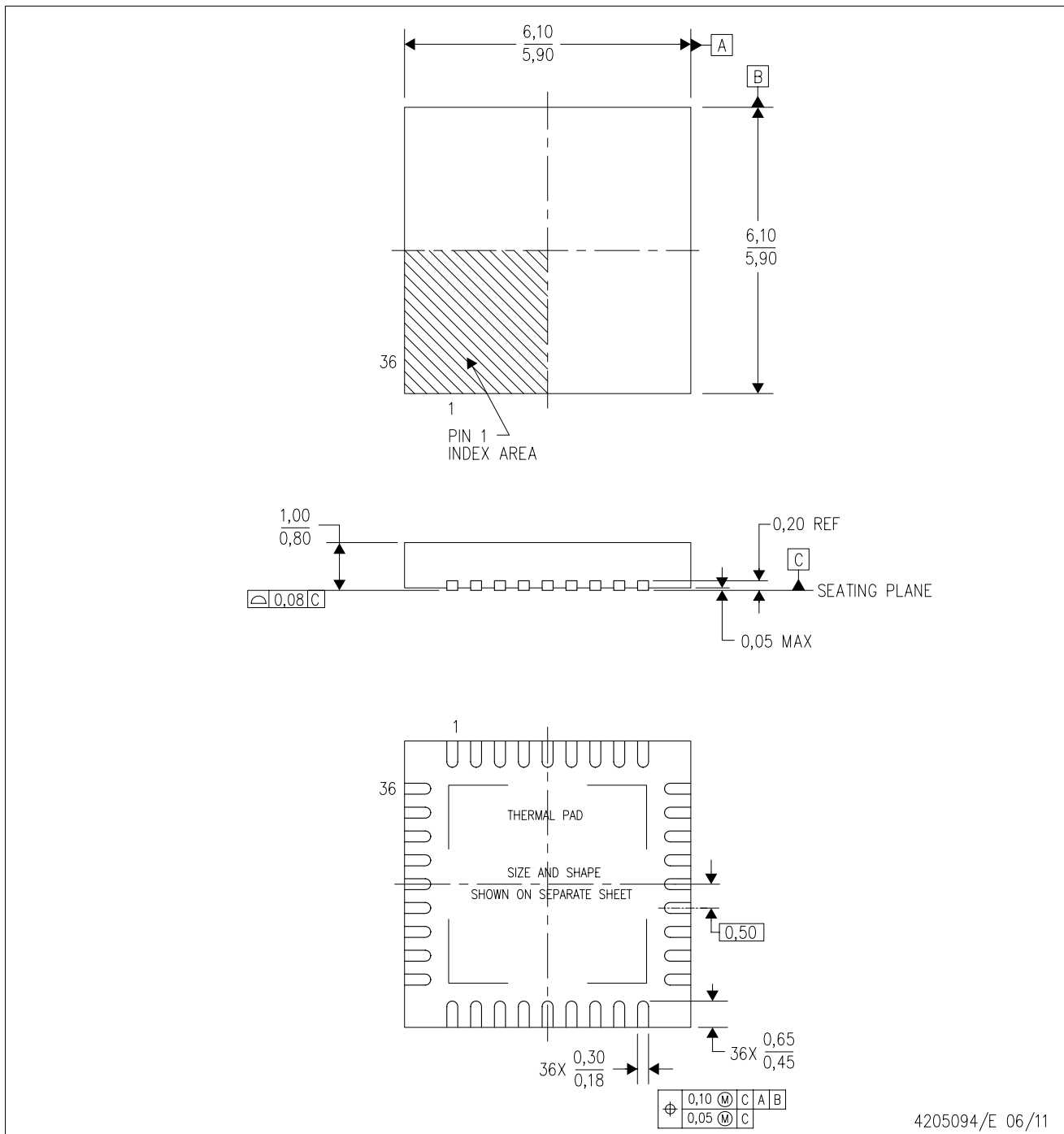

- NOTES:
- A. All linear dimensions are in millimeters. Dimensioning and tolerancing per ASME Y14.5M-1994.
 - B. This drawing is subject to change without notice.
 - C. QFN (Quad Flatpack No-Lead) Package configuration.
 - D. The package thermal pad must be soldered to the board for thermal and mechanical performance.
 - E. See the additional figure in the Product Data Sheet for details regarding the exposed thermal pad features and dimensions.
 - F. Falls within JEDEC MO-220.

THERMAL PAD MECHANICAL DATA

RHH (S-PVQFN-N36)

PLASTIC QUAD FLATPACK NO-LEAD

THERMAL INFORMATION

This package incorporates an exposed thermal pad that is designed to be attached directly to an external heatsink. The thermal pad must be soldered directly to the printed circuit board (PCB). After soldering, the PCB can be used as a heatsink. In addition, through the use of thermal vias, the thermal pad can be attached directly to the appropriate copper plane shown in the electrical schematic for the device, or alternatively, can be attached to a special heatsink structure designed into the PCB. This design optimizes the heat transfer from the integrated circuit (IC).

For information on the Quad Flatpack No-Lead (QFN) package and its advantages, refer to Application Report, QFN/SON PCB Attachment, Texas Instruments Literature No. SLUA271. This document is available at www.ti.com.

The exposed thermal pad dimensions for this package are shown in the following illustration.

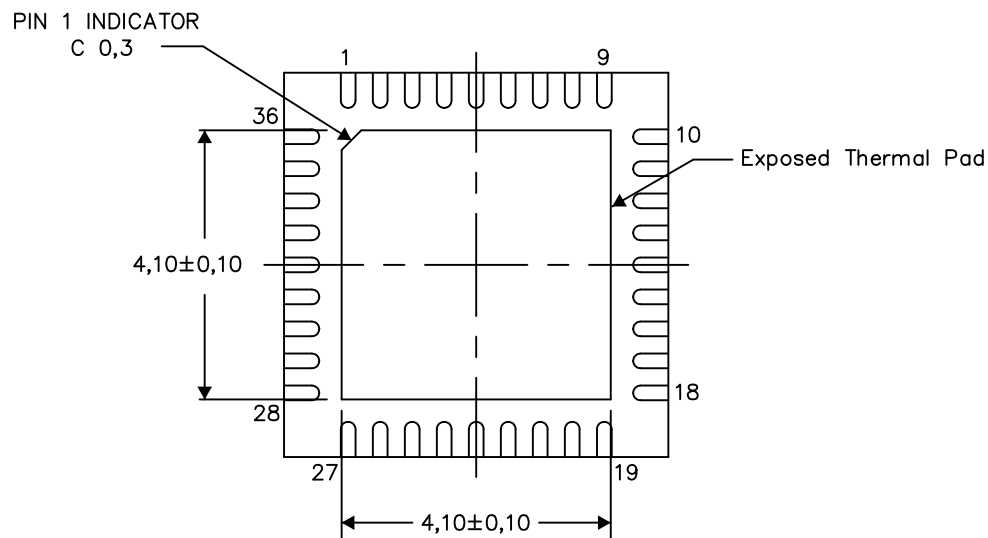

Bottom View

Exposed Thermal Pad Dimensions

4206362-3/M 11/13

NOTE: All linear dimensions are in millimeters

RHH (S-PQFP-N36)

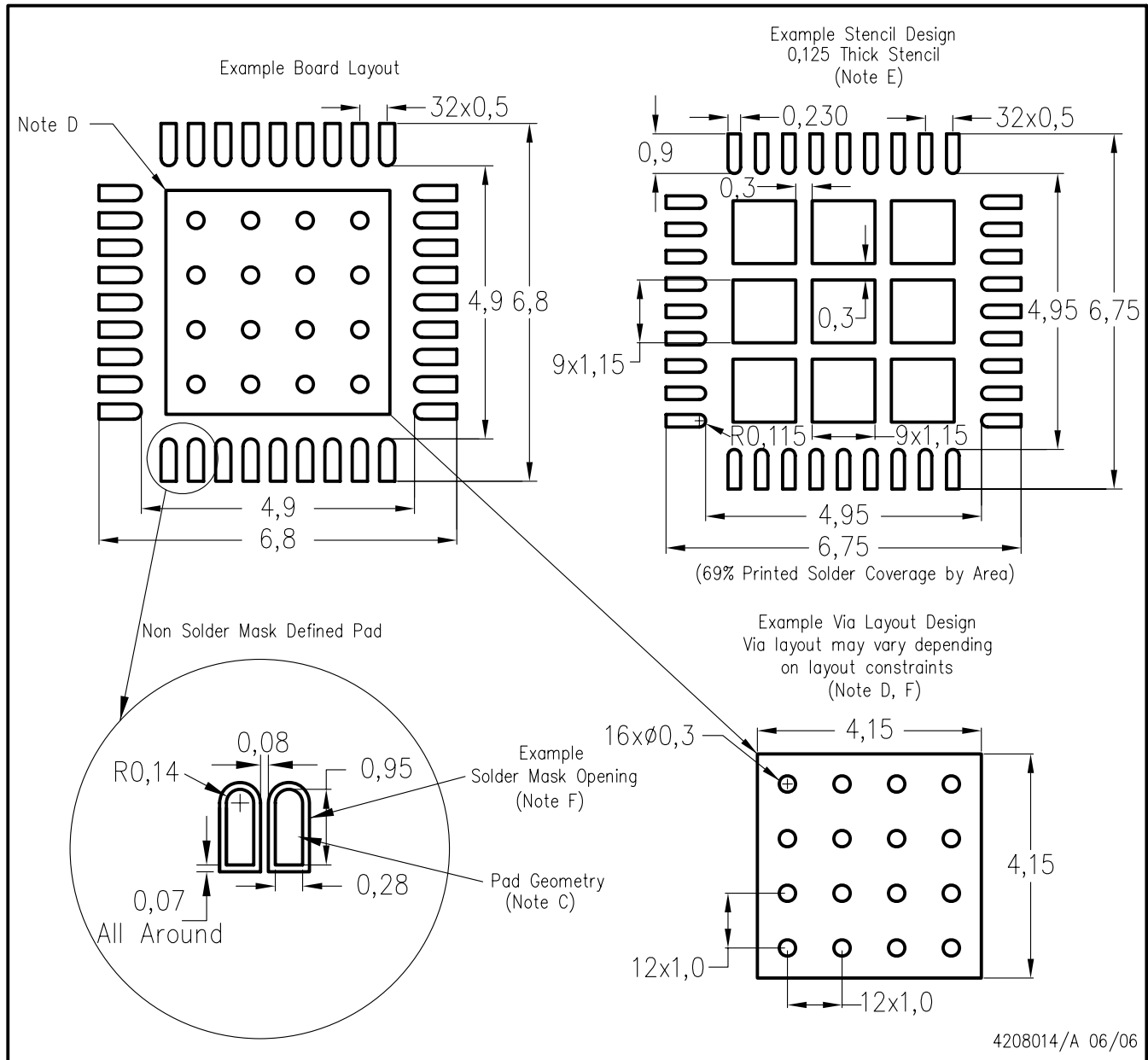

- NOTES:
- A. All linear dimensions are in millimeters.
 - B. This drawing is subject to change without notice.
 - C. Publication IPC-7351 is recommended for alternate designs.
 - D. This package is designed to be soldered to a thermal pad on the board. Refer to Application Note, Quad Flat-Pack Packages, Texas Instruments Literature No. SCBA017, SLUA271, and also the Product Data Sheets for specific thermal information, via requirements, and recommended board layout. These documents are available at www.ti.com <<http://www.ti.com>>.
 - E. Laser cutting apertures with trapezoidal walls and also rounding corners will offer better paste release. Customers should contact their board assembly site for stencil design recommendations. Refer to IPC 7525 for stencil design considerations.
 - F. Customers should contact their board fabrication site for recommended solder mask tolerances and via tenting recommendations for vias placed in the thermal pad.

IMPORTANT NOTICE

Texas Instruments Incorporated and its subsidiaries (TI) reserve the right to make corrections, enhancements, improvements and other changes to its semiconductor products and services per JESD46, latest issue, and to discontinue any product or service per JESD48, latest issue. Buyers should obtain the latest relevant information before placing orders and should verify that such information is current and complete. All semiconductor products (also referred to herein as "components") are sold subject to TI's terms and conditions of sale supplied at the time of order acknowledgment.

TI warrants performance of its components to the specifications applicable at the time of sale, in accordance with the warranty in TI's terms and conditions of sale of semiconductor products. Testing and other quality control techniques are used to the extent TI deems necessary to support this warranty. Except where mandated by applicable law, testing of all parameters of each component is not necessarily performed.

TI assumes no liability for applications assistance or the design of Buyers' products. Buyers are responsible for their products and applications using TI components. To minimize the risks associated with Buyers' products and applications, Buyers should provide adequate design and operating safeguards.

TI does not warrant or represent that any license, either express or implied, is granted under any patent right, copyright, mask work right, or other intellectual property right relating to any combination, machine, or process in which TI components or services are used. Information published by TI regarding third-party products or services does not constitute a license to use such products or services or a warranty or endorsement thereof. Use of such information may require a license from a third party under the patents or other intellectual property of the third party, or a license from TI under the patents or other intellectual property of TI.

Reproduction of significant portions of TI information in TI data books or data sheets is permissible only if reproduction is without alteration and is accompanied by all associated warranties, conditions, limitations, and notices. TI is not responsible or liable for such altered documentation. Information of third parties may be subject to additional restrictions.

Resale of TI components or services with statements different from or beyond the parameters stated by TI for that component or service voids all express and any implied warranties for the associated TI component or service and is an unfair and deceptive business practice. TI is not responsible or liable for any such statements.

Buyer acknowledges and agrees that it is solely responsible for compliance with all legal, regulatory and safety-related requirements concerning its products, and any use of TI components in its applications, notwithstanding any applications-related information or support that may be provided by TI. Buyer represents and agrees that it has all the necessary expertise to create and implement safeguards which anticipate dangerous consequences of failures, monitor failures and their consequences, lessen the likelihood of failures that might cause harm and take appropriate remedial actions. Buyer will fully indemnify TI and its representatives against any damages arising out of the use of any TI components in safety-critical applications.

In some cases, TI components may be promoted specifically to facilitate safety-related applications. With such components, TI's goal is to help enable customers to design and create their own end-product solutions that meet applicable functional safety standards and requirements. Nonetheless, such components are subject to these terms.

No TI components are authorized for use in FDA Class III (or similar life-critical medical equipment) unless authorized officers of the parties have executed a special agreement specifically governing such use.

Only those TI components which TI has specifically designated as military grade or "enhanced plastic" are designed and intended for use in military/aerospace applications or environments. Buyer acknowledges and agrees that any military or aerospace use of TI components which have **not** been so designated is solely at the Buyer's risk, and that Buyer is solely responsible for compliance with all legal and regulatory requirements in connection with such use.

TI has specifically designated certain components as meeting ISO/TS16949 requirements, mainly for automotive use. In any case of use of non-designated products, TI will not be responsible for any failure to meet ISO/TS16949.

Products

Audio	www.ti.com/audio
Amplifiers	amplifier.ti.com
Data Converters	dataconverter.ti.com
DLP® Products	www.dlp.com
DSP	dsp.ti.com
Clocks and Timers	www.ti.com/clocks
Interface	interface.ti.com
Logic	logic.ti.com
Power Mgmt	power.ti.com
Microcontrollers	microcontroller.ti.com
RFID	www.ti-rfid.com
OMAP Applications Processors	www.ti.com/omap
Wireless Connectivity	www.ti.com/wirelessconnectivity

Applications

Automotive and Transportation	www.ti.com/automotive
Communications and Telecom	www.ti.com/communications
Computers and Peripherals	www.ti.com/computers
Consumer Electronics	www.ti.com/consumer-apps
Energy and Lighting	www.ti.com/energy
Industrial	www.ti.com/industrial
Medical	www.ti.com/medical
Security	www.ti.com/security
Space, Avionics and Defense	www.ti.com/space-avionics-defense
Video and Imaging	www.ti.com/video

TI E2E Community

e2e.ti.com