

TS3DDR4000 12-bits 1:2 High Speed DDR2/DDR3/DDR4 Switch/Multiplexer

1 Features

- Wide V_{DD} Range: 2.375 V – 3.6 V
- High Bandwidth: 5.6 GHz Typical (single-ended); 6.0 GHz Typical (differential)
- Low Switch On-Resistance (R_{ON}): 8 Ω Typical
- Low Bit-to-Bit Skew: 3ps Typical; 6ps Max across All Channels
- Low Crosstalk: –34 dB Typical at 1067 MHz
- Low Operating Current: 40 μ A Typical
- Low-Power Mode with Low Current Consumption: 2 μ A Typical
- I_{OFF} Protection Prevents Current Leakage in Powered Down State ($V_{DD} = 0$ V)
- Supports POD_12, SSTL_12, SSTL_15 and SSTL_18 Signaling
- ESD Performance:
 - 3-kV Human Body Model (A114B, Class II)
 - 1-kV Charged Device Model (C101)
- 8 mm x 3 mm 48-balls 0.65-mm Pitch ZBA Package

2 Applications

- NVDIMM Modules
- Enterprise Data Systems and Servers
- Notebook/Desktop PCs
- General DDR3/DDR4 Signal Switching
- General High-Speed Signal Switching

3 Description

The TS3DDR4000 is 1:2 or 2:1 high speed DDR2/DDR3/DDR4 switch that offers 12-bit wide bus switching. The A port can be switched to the B or C port for all bits simultaneously. Designed for operation in DDR2, DDR3 and DDR4 memory bus systems, the TS3DDR4000 uses a proprietary architecture that delivers high bandwidth (single-ended –3dB bandwidth at 5.6 GHz), low insertion loss at low frequency, and very low propagation delay. The TS3DDR4000 is 1.8 V logic compatible, and all switches are bi-directional for added design flexibility. The TS3DDR4000 also offers a low-power mode, in which all channels become high-Z and the device consumes minimal power.

Device Information⁽¹⁾

PART NUMBER	PACKAGE	BODY SIZE (NOM)
TS3DDR4000	NFBGA (48)	8.00 mm x 3.00 mm

(1) For all available packages, see the orderable addendum at the end of the datasheet.

4 Application Diagram

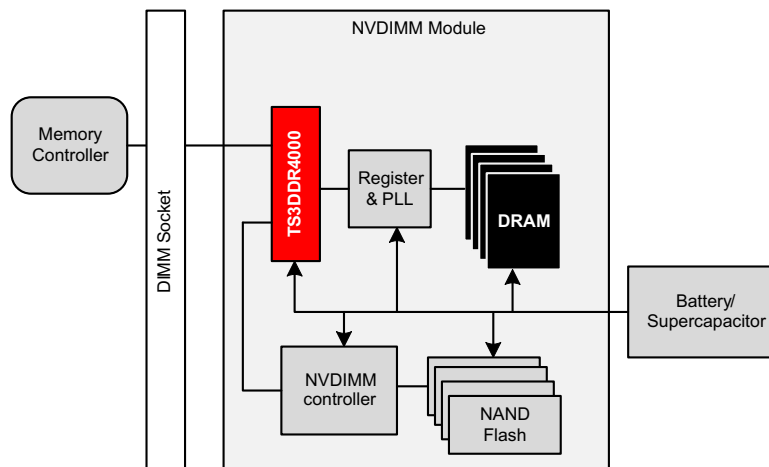

Table of Contents

1 Features	1	9.1 Overview	11
2 Applications	1	9.2 Functional Block Diagram	11
3 Description	1	9.3 Feature Description	12
4 Application Diagram	1	9.4 Device Functional Modes	12
5 Revision History	2	10 Application and Implementation	13
6 Pin Configuration and Functions	3	10.1 Application Information	13
7 Specifications	4	10.2 Typical Application	13
7.1 Absolute Maximum Ratings	4	11 Power Supply Recommendations	14
7.2 ESD Ratings	4	12 Layout	15
7.3 Recommended Operating Conditions	4	12.1 Layout Guidelines	15
7.4 Thermal Information	4	12.2 Layout Example	18
7.5 Static Electrical Characteristics	5	13 Device and Documentation Support	19
7.6 Dynamic Electrical Characteristics	6	13.1 Trademarks	19
7.7 Typical Characteristics	7	13.2 Electrostatic Discharge Caution	19
8 Parameter Measurement Information	9	13.3 Glossary	19
9 Detailed Description	11	14 Mechanical, Packaging, and Orderable Information	19

5 Revision History

Changes from Original (November 2014) to Revision A

Page

• Updated document to full version.	1
--	----------

6 Pin Configuration and Functions

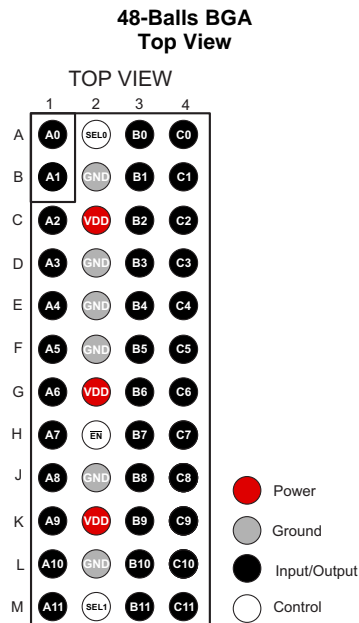

Pin Functions

PINS		TYPE	DESCRIPTION
NAME	NO.		
VDD	C2, G2, K2	Power	Power supply
GND	B2, D2, E2, F2, J2, L2	Ground	Ground
A0-A11	A1-M1	I/O	Port A, signal 0-11
B0-B11	A3-M3	I/O	Port B, signal 0-11
C0-C11	A4-M4	I/O	Port C, signal 0-11
SEL0	A2	I	Select control 0
SEL1	M2	I	Select control 1
/EN	H2	I	Enable

7 Specifications

7.1 Absolute Maximum Ratings

over operating free-air temperature range (unless otherwise noted) ⁽¹⁾

		MIN	MAX	UNIT
V _{DD}	Voltage range on V _{DD}	-0.3	5.5	V
V _{IN}	Control input voltage range: SEL0, SEL1, and /EN	-0.3	5.5	V
V _{IO}	Analog voltage range: A0-A11, B0-B11, and C0-C11	-0.3	3.6	V
T _A	Operating ambient temperature range	-40	85	°C
T _{stg}	Storage temperature range	-65	125	°C

(1) Stresses beyond those listed under *Absolute Maximum Ratings* may cause permanent damage to the device. These are stress ratings only, which do not imply functional operation of the device at these or any other conditions beyond those indicated under *Recommended Operating Conditions*. Exposure to absolute-maximum-rated conditions for extended periods may affect device reliability.

7.2 ESD Ratings

			VALUE	UNIT
V _(ESD)	Electrostatic discharge	Charge device model (CDM) ⁽¹⁾	±1000	V
		Human body model (HBM) on all pins ⁽²⁾	±3000	V

(1) Tested in accordance with JEDEC Standard 22, Test Method C101

(2) Tested in accordance with JEDEC Standard 22, Test Method A114

7.3 Recommended Operating Conditions

over operating free-air temperature range (unless otherwise noted)

		MIN	MAX	UNIT
V _{DD}	Voltage range on V _{DD}	2.375	3.6	V
V _{IO}	Analog voltage range: A0-A11, B0-B11, and C0-C11	0	3.3	V
V _{IH}	High-level control input voltage threshold (/EN, SEL1m and SEL2)	1.4	V _{DD}	V
V _{IL}	Low-level control input voltage threshold (/EN, SEL1m and SEL2)	0	0.5	V
T _A	Operating ambient temperature range	-40	85	°C

7.4 Thermal Information

THERMAL METRIC ⁽¹⁾		TS3DDR4000	UNIT
		BGA (48)	
R _{θJA}	Junction-to-ambient thermal resistance	92.6	°C/W
R _{θJC(top)}	Junction-to-case (top) thermal resistance	33.4	
R _{θJB}	Junction-to-board thermal resistance	56.2	
Ψ _{JT}	Junction-to-top characterization parameter	1.3	
Ψ _{JB}	Junction-to-board characterization parameter	54.9	

(1) For more information about traditional and new thermal metrics, see the *IC Package Thermal Metrics* application report .

7.5 Static Electrical Characteristics

Unless otherwise noted the specification applies over the V_{DD} range and operation junction temp of $-40^{\circ}\text{C} \leq T_J \leq 85^{\circ}\text{C}$.

Typical values are for $V_{DD} = 3.3\text{ V}$ and $T_J = 25^{\circ}\text{C}$.

PARAMETER		TEST CONDITION		MIN	TYP	MAX	UNIT
R_{ON}	On-state resistance	Port A to B	$V_{DD} = 2.375\text{ V}$, $V_{I/O} = 1.2\text{ V}$, $I_{I/O} = 10\text{ mA}$	–	8.3	11.2	Ω
		Port A to C		–	8.3	11.2	Ω
R_{ON} (FLAT)	On-state resistance flatness for all I/Os	Port A to B	$V_{DD} = 2.375\text{ V}$, $V_{I/O} = 1.2\text{ V}$, $I_{I/O} = 10\text{ mA}$	–	0.6	–	Ω
		Port A to C		–	0.6	–	Ω
ΔR_{ON}	On-state resistance match between channels	Port A to B	$V_{DD} = 2.375\text{ V}$, $V_{I/O} = 1.2\text{ V}$, $I_{I/O} = 10\text{ mA}$	–	0.2	1.0	Ω
		Port A to C		–	0.2	1.0	Ω
I_{IH}	Control input high leakage current	EN	$V_{DD} = 3.6\text{ V}$, $V_{/EN} = 1.4\text{ V}$	–	–	± 1	μA
			$V_{DD} = 2.375\text{ V}$, $V_{/EN} = 3.3\text{ V}$	–	–	± 1	μA
		SEL1	$V_{DD} = 3.6\text{ V}$, $V_{SEL1} = 1.4\text{ V}$	–	–	± 1	μA
			$V_{DD} = 2.375\text{ V}$, $V_{SEL1} = 3.3\text{ V}$	–	–	± 1	μA
		SEL2	$V_{DD} = 3.6\text{ V}$, $V_{SEL2} = 1.4\text{ V}$	–	–	± 1	μA
			$V_{DD} = 2.375\text{ V}$, $V_{SEL2} = 3.3\text{ V}$	–	–	± 1	μA
I_{IL}	Control input low leakage current	EN	$V_{DD} = 3.6\text{ V}$, $V_{/EN} = 0\text{ V}$	–	–	± 0.5	μA
		SEL1	$V_{DD} = 3.6\text{ V}$, $V_{SEL1} = 0\text{ V}$	–	–	± 0.5	μA
		SEL2	$V_{DD} = 3.6\text{ V}$, $V_{SEL2} = 0\text{ V}$	–	–	± 0.5	μA
I_{OFF}	Leakage under power off condition for all I/Os	EN	$V_{DD} = 0\text{ V}$, $V_{/EN} = 0\text{ V}$, $V_{I/O} = 0\text{ V}$ to 3.3 V	–	–	± 5	μA
			$V_{DD} = 0\text{ V}$, $V_{/EN} = 3.6\text{ V}$, $V_{I/O} = 0\text{ V}$ to 3.3 V	–	–	± 5	μA
		SEL1	$V_{DD} = 0\text{ V}$, $V_{SEL1} = 0\text{ V}$, $V_{I/O} = 0\text{ V}$ to 3.3 V	–	–	± 5	μA
			$V_{DD} = 0\text{ V}$, $V_{SEL1} = 3.6\text{ V}$, $V_{I/O} = 0\text{ V}$ to 3.3 V	–	–	± 5	μA
		SEL2	$V_{DD} = 0\text{ V}$, $V_{SEL2} = 0\text{ V}$, $V_{I/O} = 0\text{ V}$ to 3.3 V	–	–	± 5	μA
			$V_{DD} = 0\text{ V}$, $V_{SEL2} = 3.6\text{ V}$, $V_{I/O} = 0\text{ V}$ to 3.3 V	–	–	± 5	μA
I_{DD}	V_{DD} supply current		$V_{DD} = 3.6\text{ V}$, $I_{I/O} = 0\text{ A}$, $/EN = 0\text{ V}$, $V_{SEL1} = V_{SEL2} = 0\text{ V}$	–	28	35	μA
			$V_{DD} = 3.6\text{ V}$, $I_{I/O} = 0\text{ A}$, $/EN = 0\text{ V}$, $V_{SEL1} = V_{SEL2} = 1.8\text{ V}$	–	40	48	μA
			$V_{DD} = 3.6\text{ V}$, $I_{I/O} = 0\text{ A}$, $/EN = 0\text{ V}$, $V_{SEL1} = 0\text{ V}$, $V_{SEL2} = 1.8\text{ V}$	–	40	44	μA
			$V_{DD} = 3.6\text{ V}$, $I_{I/O} = 0\text{ A}$, $/EN = 0\text{ V}$, $V_{SEL1} = 1.8\text{ V}$, $V_{SEL2} = 0\text{ V}$	–	40	44	μA
$I_{DD, PD}$	V_{DD} supply current in power-down mode		$V_{DD} = 3.6\text{ V}$, $I_{I/O} = 0\text{ A}$, $/EN = 1.8\text{ V}$	–	2	5	μA

7.6 Dynamic Electrical Characteristics

over operating free-air temperature range (unless otherwise noted)

PARAMETER		TEST CONDITION		MIN	TYP	MAX	UNIT
t _{ON}	Switch turn-on time	EN to B	V _{DD} = 2.375 V, R _L = 50 Ω, V _{An} = 3.3 V, V _{EN} = 1.8 V → 0 V, V _{SEL1} = V _{SEL2} = 0 V (See Figure 12)	–	65	140	μs
		EN to C	V _{DD} = 2.375 V, R _L = 50 Ω, V _{An} = 3.3 V, V _{EN} = 1.8 V → 0 V, V _{SEL1} = V _{SEL2} = 1.8 V (See Figure 12)	–	65	140	μs
t _{SWITCH}	Switching time between channels for all I/Os	SEL to B	V _{DD} = 2.375 V, V _{EN} = 0 V, R _L = 50 Ω, V _{An} = 3.3 V, (See Figure 13)	–	65	–	ns
		SEL to C	V _{DD} = 2.375 V, V _{EN} = 0 V, R _L = 50 Ω, V _{An} = 3.3 V, (See Figure 13)	–	50	–	ns
t _{PD}	Propagation delay	Port A to B	V _{DD} = 2.375 V, (See Figure 14)	–	85	–	ps
		Port A to C	V _{DD} = 2.375 V, (See Figure 14)	–	85	–	ps
t _{SKEW} ⁽¹⁾	Single-ended skew between channels	B0 to B11	V _{DD} = 2.375 V, from any output to any other output	–	3	8	ps
		C0 to C11		–	3	6	ps
C _{IN}	Control input capacitance	EN	f = 1 MHz, V _{IN} = 0 V	–	6	–	pF
		SEL1	f = 1 MHz, V _{IN} = 0 V	–	6	–	pF
		SEL2	f = 1 MHz, V _{IN} = 0 V	–	6	–	pF
C _{OFF}	Switch off capacitance	Port A to B	f = 1067 MHz, V _{I/O} = 0 V, V _{SEL1} = V _{SEL2} = 1.8V	–	0.5	–	pF
		Port A to C	f = 1067 MHz, V _{I/O} = 0 V, V _{SEL1} = V _{SEL2} = 0 V	–	0.5	–	pF
C _{ON}	Switch on capacitance	Port A to B	f = 1067 MHz, V _{I/O} = 1.2 V, V _{SEL1} = V _{SEL2} = 0V	–	1.0	–	pF
		Port A to C	f = 1067 MHz, V _{I/O} = 1.2 V, V _{SEL1} = V _{SEL2} = 1.8V	–	1.0	–	pF
X _{TALK}	Crosstalk between channels	B0 to B11	f = 1067 MHz, V _{SEL1} = V _{SEL2} = 0 V, R _L = 50 Ω	–	-34	–	dB
		C0 to C11	f = 1067 MHz, V _{SEL1} = V _{SEL2} = 1.8 V, R _L = 50 Ω	–	-31	–	dB
O _{ISO}	Off-isolation	Port A to B	f = 1067 MHz, V _{SEL1} = V _{SEL2} = 1.8 V, R _L = 50 Ω	–	-21	–	dB
		Port A to C	f = 1067 MHz, V _{SEL1} = V _{SEL2} = 0 V, R _L = 50 Ω	–	-21	–	dB
I _L	Insertion loss (channel on)	Port A to B	f = DC, R _L = 50 Ω	–	-0.75	-1	dB
		Port A to C	f = DC, R _L = 50 Ω	–	-0.75	-1	dB
BW _{SE}	-3 dB bandwidth (Single-ended)	Port A to B	R _L = 50 Ω	–	5.6	–	GHz
		Port A to C		–	5.6	–	
BW _{DIFF}	-3 dB bandwidth (Differential)	Port A to B	R _L = 100 Ω	–	6	–	GHz
		Port A to C		–	6	–	

(1) Verified by design.

7.7 Typical Characteristics

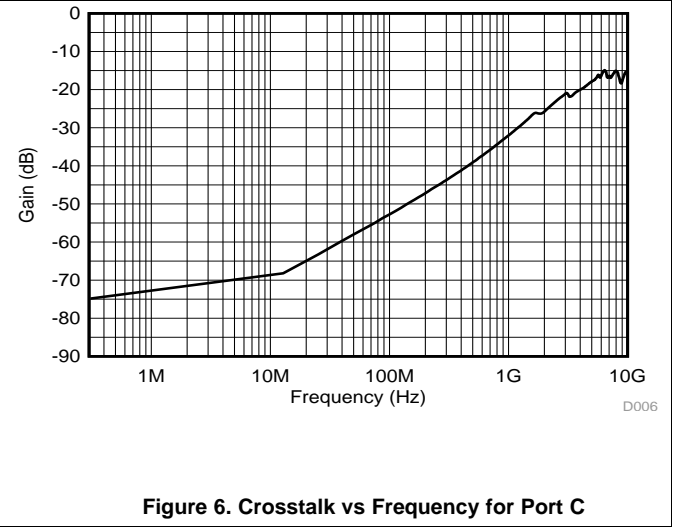
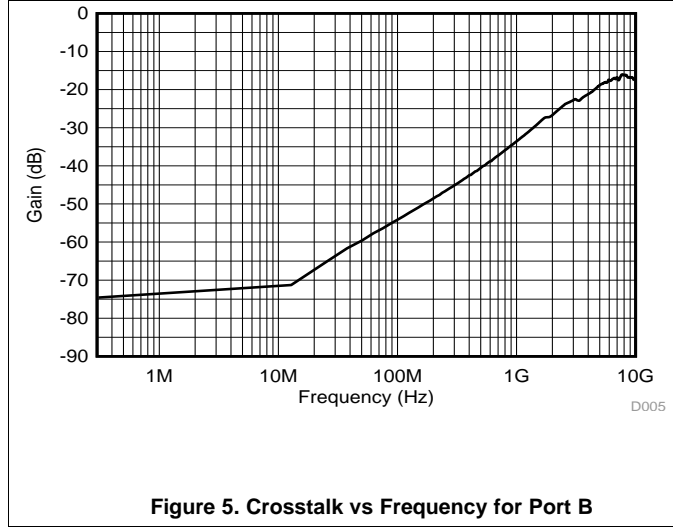
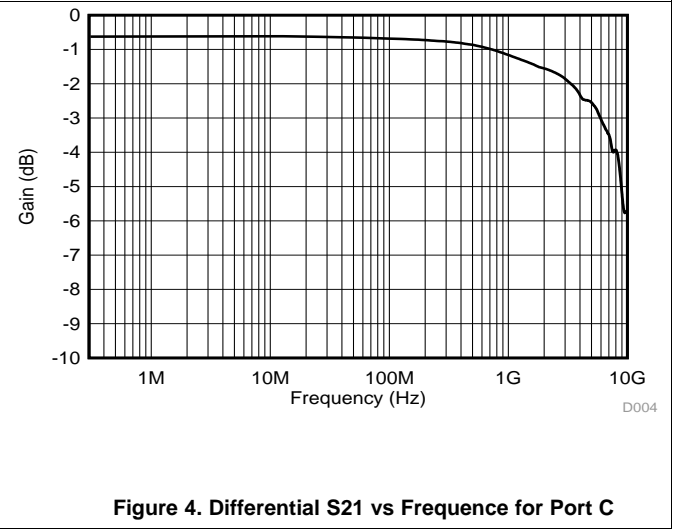
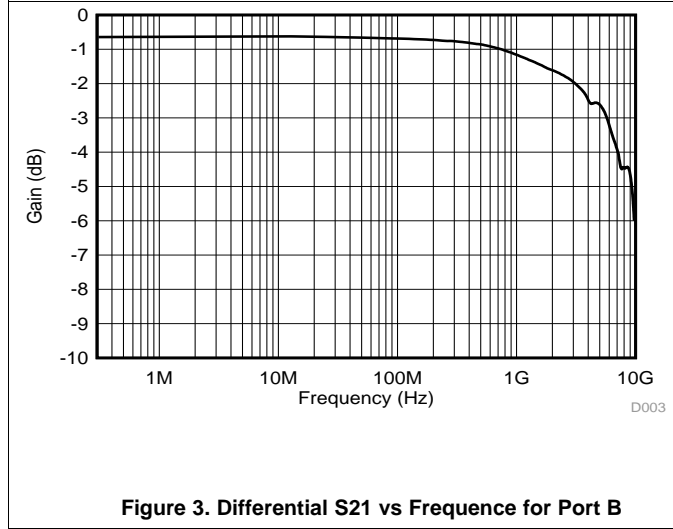
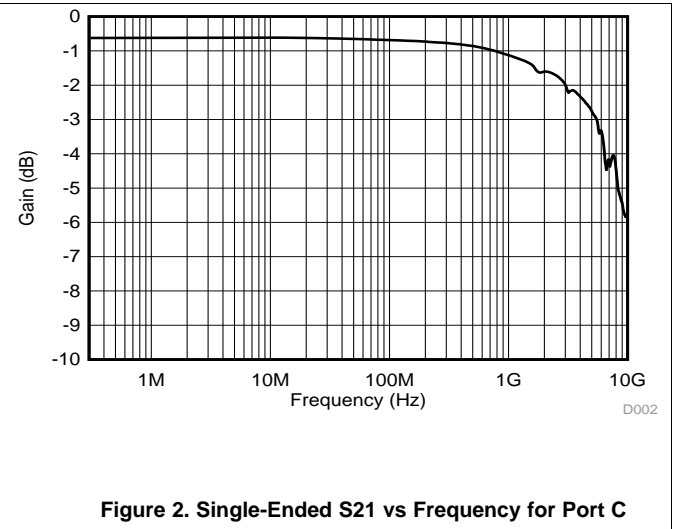
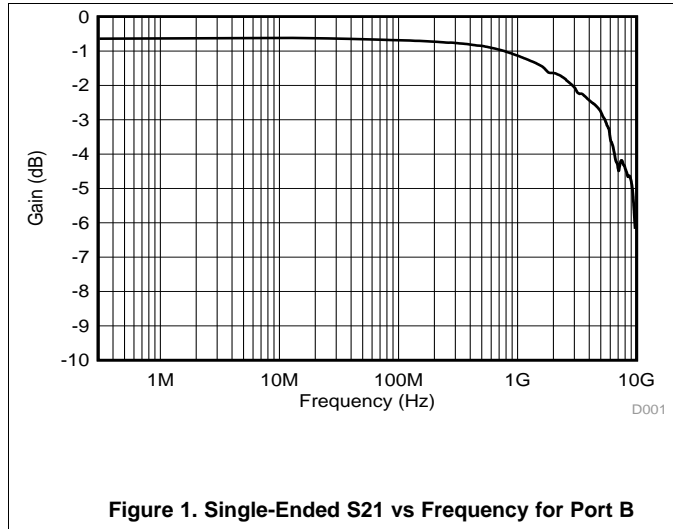

Typical Characteristics (continued)

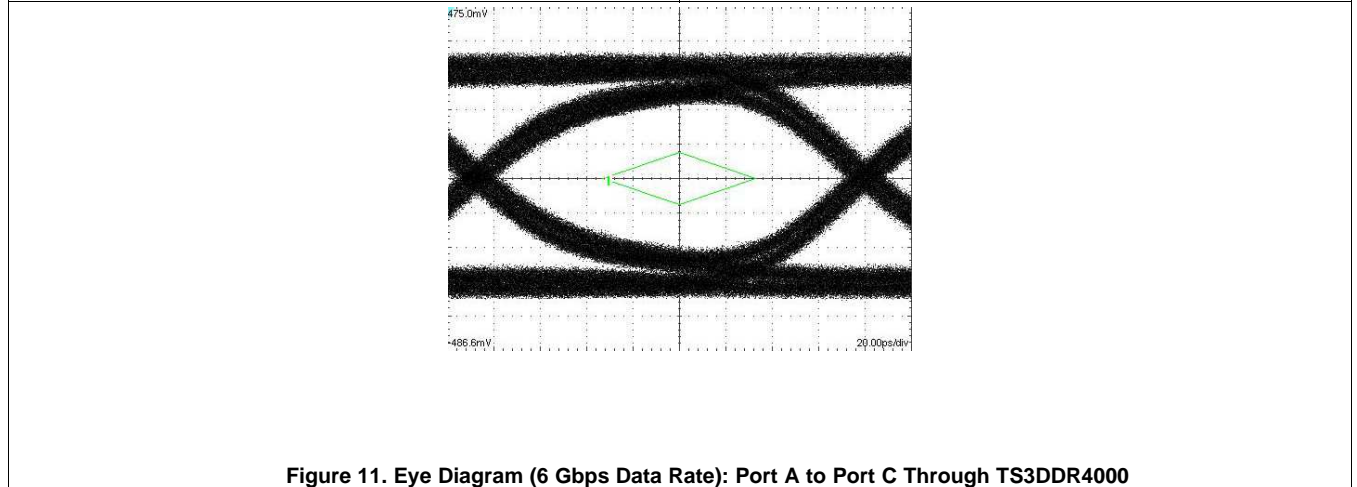
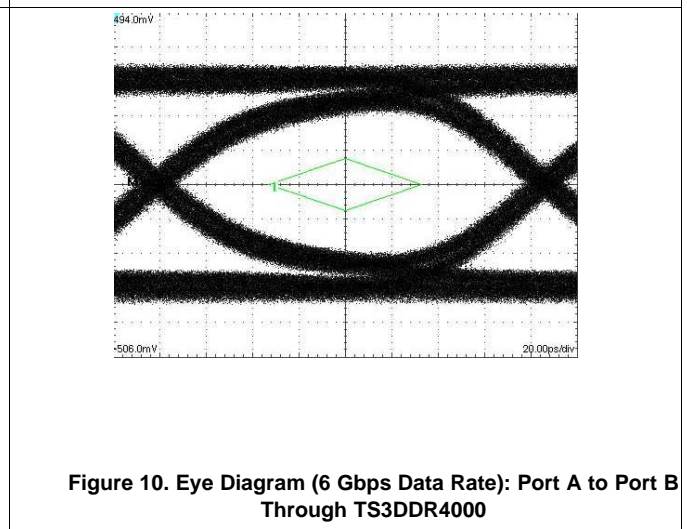
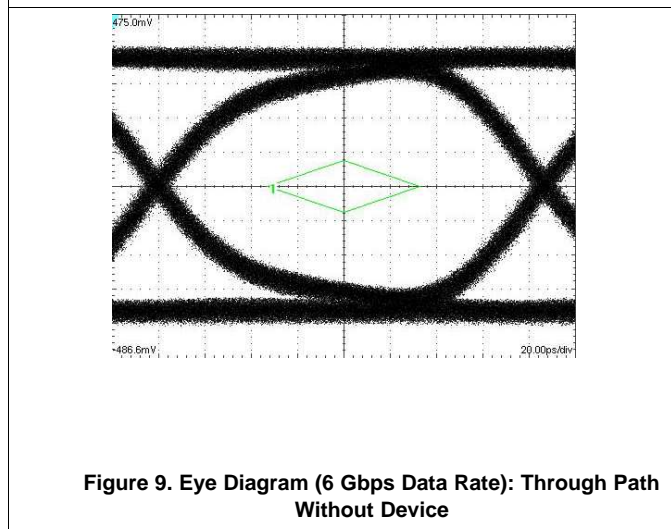
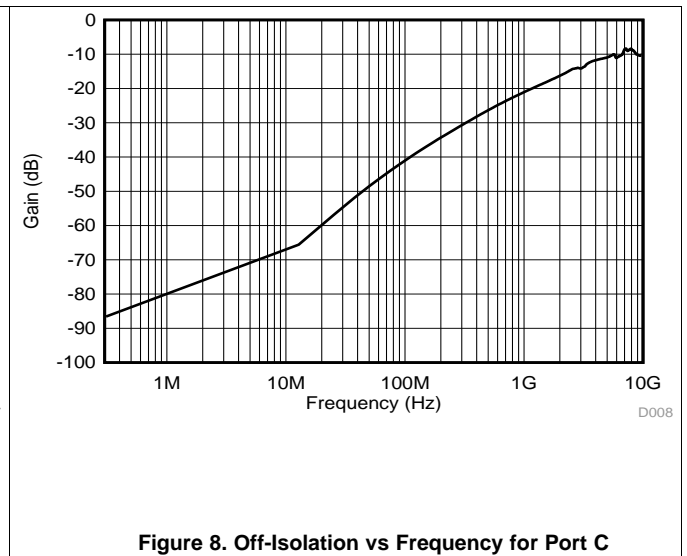
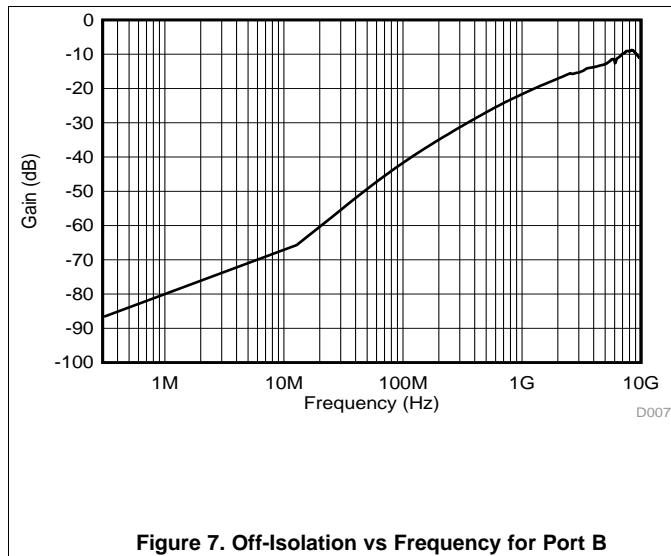

8 Parameter Measurement Information

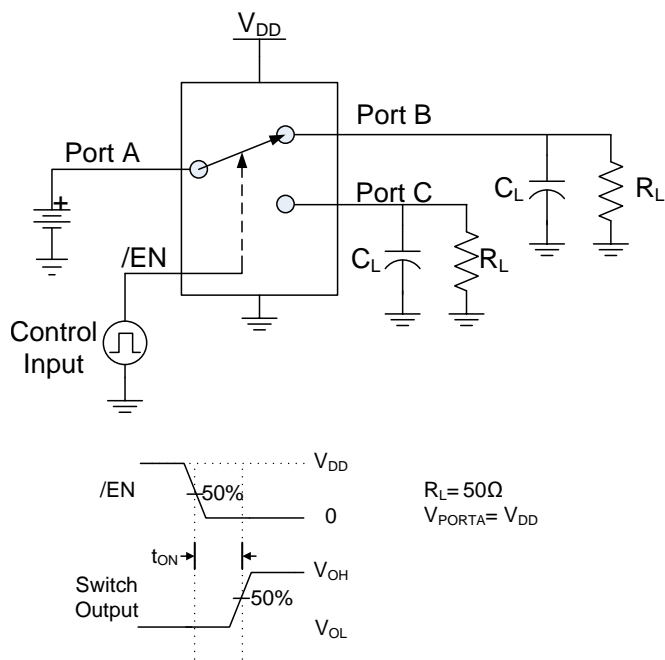

Figure 12. Switch Turn-on Time (t_{ON}) Measurement

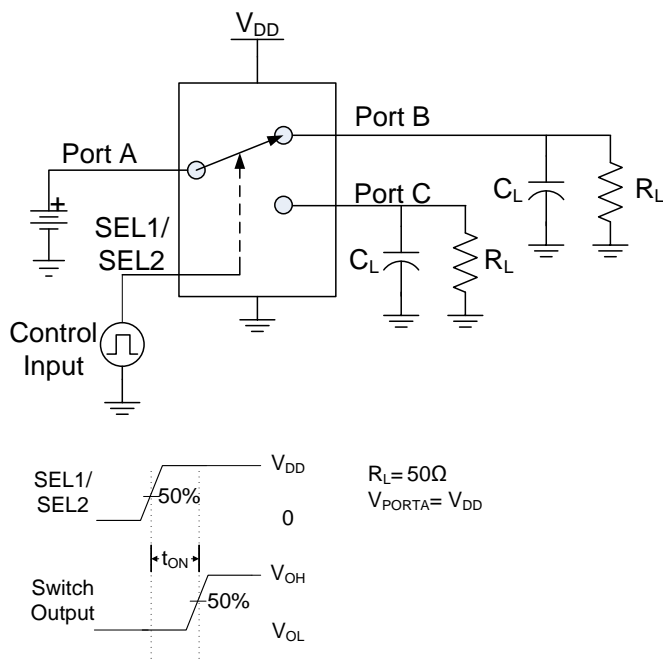

Figure 13. Switch Switching Time (t_{SWITCH}) Measurement

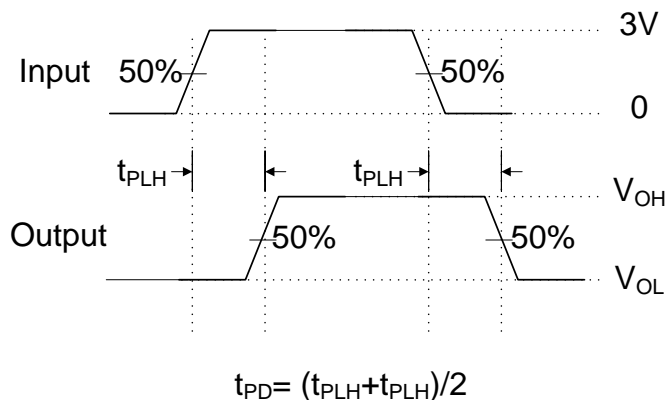

Figure 14. Propagation Delay (t_{PD}) Measurement

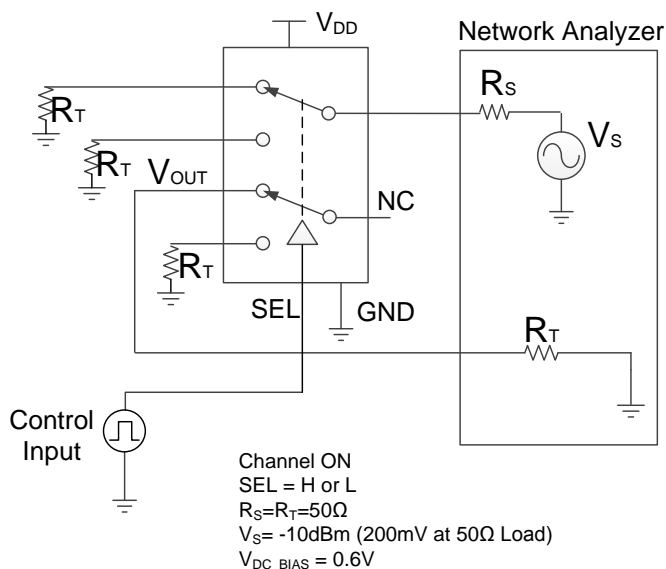

Figure 15. Crosstalk Measurement

Parameter Measurement Information (continued)

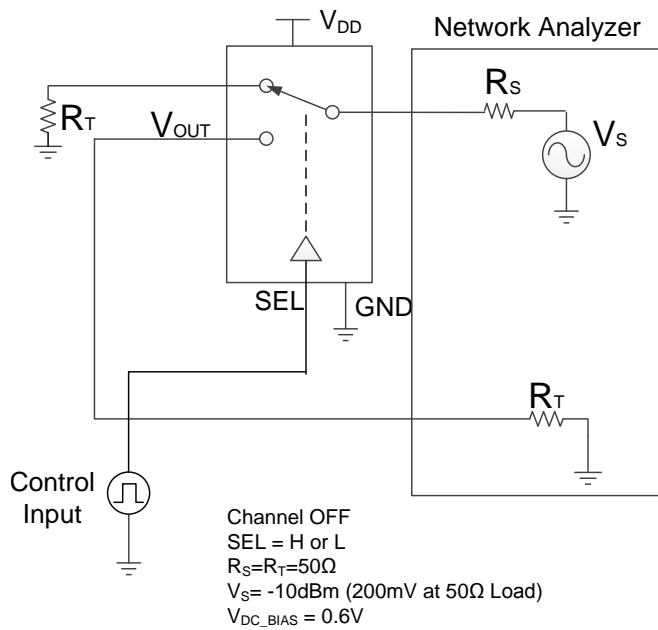

Figure 16. Off Isolation Measurement

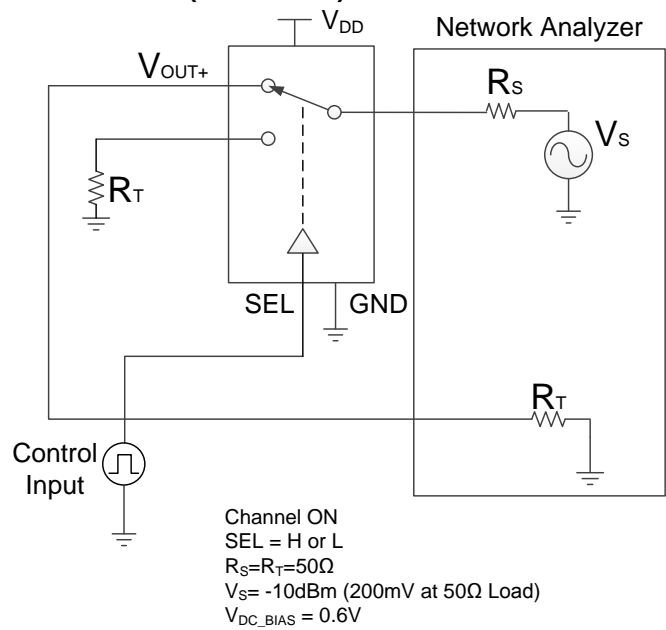

Figure 17. Bandwidth Measurement

9 Detailed Description

9.1 Overview

The TS3DDR4000 is 1:2 or 2:1 high speed DDR2/DDR3/DDR4 switch that offers 12-bit wide bus switching. The A port can be routed to the B or C port for all bits simultaneously. Designed for operation in DDR2, DDR3 and DDR4 memory bus systems that support POD_12, SSTL_12, SSTL_135, SSTL_15, or SSTL_18 signaling, the TS3DDR4000 uses a proprietary architecture that delivers high bandwidth (differential -3dB bandwidth of up to 6.0 GHz), and very low propagation delay and skew across all channels. The TS3DDR4000 is 1.8 V logic compatible, and all switches are bi-directional for added design flexibility. The TS3DDR4000 also offers a low-power mode, in which all channels become high-Z and the device operates with minimal power.

9.2 Functional Block Diagram

The following diagram (Figure 18) represents the switch function block diagram of the TS3DDR4000. Port A (A0-A11) can be routed to either port B (B0-B11) or port C (C0-C11) by configuring the SEL1 and SEL2 pins. The EN pin can be toggled high to put the device into the low-power mode with minimal power consumption.

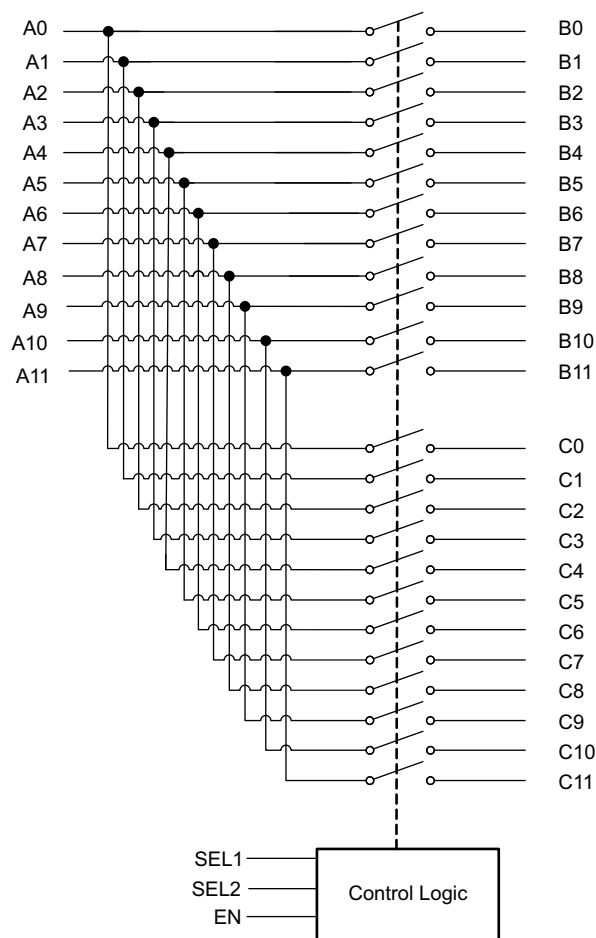

Figure 18. TS3DDR4000 Switch Function Block Diagram

9.3 Feature Description

- I_{OFF} Protection: When no power is provided to the device ($V_{CC} = 0\text{ V}$), the TS3DDR4000 prevents any I/O signals from back-powering the device. The leakage current is tightly controlled under such condition (refer to the I_{OFF} in the [Specifications](#) section) so it does not cause any system issues.
- Low-power mode: The \overline{EN} pin can be driven high to make the TS3DDR4000 enter the low-power mode. When in low power mode, all channels are isolated and the device consumes less than 5 μA of current.

9.4 Device Functional Modes

When \overline{EN} pin is driven high, the TS3DDR4000 enters into the power-down mode, in which all channels are isolated and the device consumes less than 5 μA of current. When EN pin is driven low, the A port is routed to either B port or C port depending on the configuration of SEL0 and SEL1 signals. The B and C port can also be partially turned on when SEL0 and SEL1 are not both high or both low. Refer to [Table 1](#) for the control logic details.

Table 1. Logic Control Table

CONTROL PINS			FUNCTION
\overline{EN}	SEL0	SEL1	
H	X	X	Power –down mode. All channels off (isolated)
L	L	L	Port A to port B ON Port A to port C OFF (isolated)
L	L	H	A [0,1,4,5,8,9] ↔ B [0,1,4,5,8,9] A [2,3,6,7,10,11] ↔ C [2,3,6,7,10,11] All other channels OFF (isolated)
L	H	L	A [2,3,6,7,10,11] ↔ B [2,3,6,7,10,11] A [0,1,4,5,8,9] ↔ C [0,1,4,5,8,9] All other channels OFF (isolated)
L	H	H	Port A to port B OFF (isolated) Port A to port C ON

10 Application and Implementation

10.1 Application Information

The TS3DDR4000 is a high-speed switch targeted for DDR memory applications that require 1:2 or 2:1 switching. The following sections describe two application scenarios that are widely used. In addition to memory applications, the TS3DDR4000 can also be used for generic high-speed switching that requires high bandwidth and minimal signal degradation.

10.2 Typical Application

10.2.1 Non-Volatile Dual In-line Memory Module (NVDIMM) application

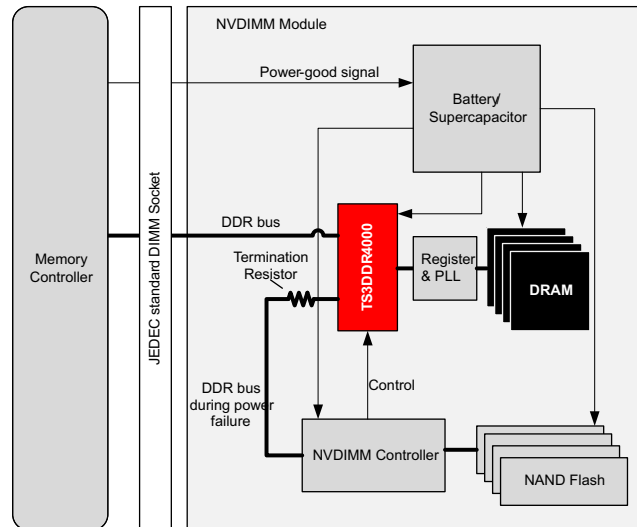

Figure 19. TS3DDR4000 Used In NVDIMM Application

10.2.1.1 Design Requirements

The TS3DDR4000 can be used in the NVDIMM application to provide server systems reliable data backups when the system encounters power-failure conditions. Figure 19 depicts a typical NVDIMM design utilizing the TS3DDR4000.

In normal system operation, the TS3DDR4000 routes the DDR signals between the system and the DRAM for normal data access. When the system encounters power failure, the charge stored in the battery or the super capacitor is used to power the NVDIMM controller, which configures the TS3DDR4000 to save the data from DRAM into the NAND Flash. The NAND Flash is non-volatile in nature, so the data stored internally stays intact even when the power goes away eventually. When the system power comes back on, the NVDIMM controller can re-route the data from the NAND Flash through the TS3DDR4000 back into the DRAM and can subsequently re-start the normal system operation.

10.2.1.2 Detailed Design Procedure

The battery or the super capacitor needs to be designed to have enough capacity to maintain the power long enough for the backup procedure to be completed. At a backup speed of 128 MB/sec, it takes about 10 seconds per 1 GB to either backup or restore the data. Typically a super capacitor is preferred for its longer life of operation. The super capacitor is usually a separate module and is connected to the NVDIMM via a cable.

NVDIMMs require support from the system motherboard. When plugged in, the BIOS must recognize the NVDIMMs. Manufacturers who control the BIOS and MRC (memory reference code) can make the necessary code changes to implement NVDIMMs into their servers.

Typical Application (continued)

10.2.2 Load Isolation Application

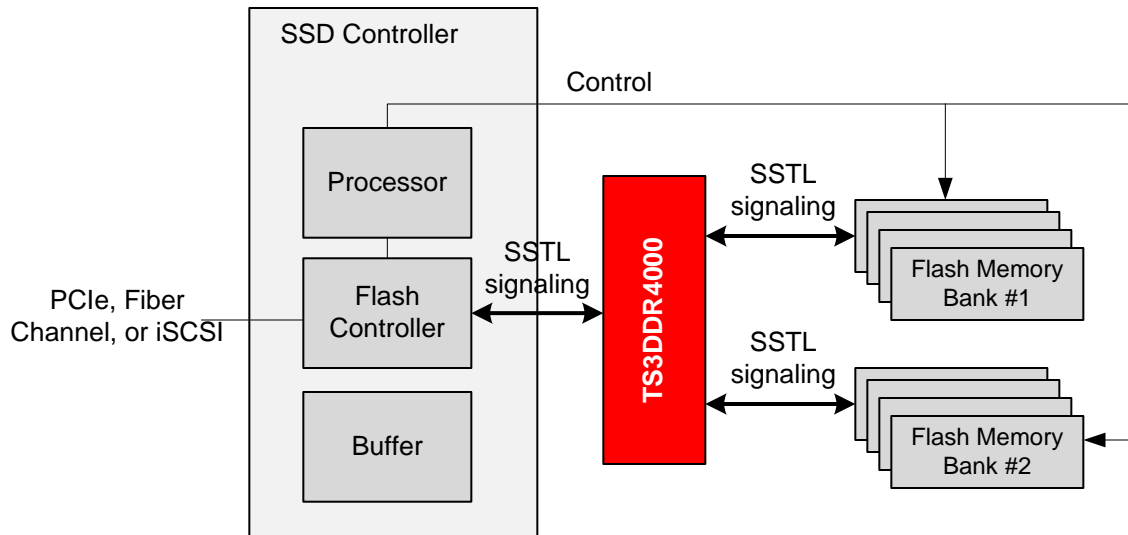

Figure 20. TS3DDR4000 Used In Load Isolation Application

10.2.2.1 Design Requirements

In recent years, the size of Solid-State-Drives (SSDs) has increased rapidly, making it necessary to increase the number of flash memory devices in each drive. The flash memory devices sometimes share the same control and data channel to communicate with the controller. This causes increased loading to each communication channel as the number of flash memory devices increases. To meet the performance requirement of an SSD, the ability to isolate the loading becomes necessary.

10.2.2.2 Detailed Design Procedure

As depicted in [Figure 20](#), the TS3DDR4000 can be used for load isolation purpose. Flash memory bank #1 and #2 can share the same communication channel to the flash controller without increasing the loading to each other. While the TS3DDR4000 is enabled for one channel, the other channel is fully isolated. The off-isolation specification is about -21 dB at 1067 MHz, as described in the [Specifications](#) section.

11 Power Supply Recommendations

V_{DD} should be in the range of 2.375 V to 3.6 V. A 0.1 μ F or higher decoupling capacitors placed as close to the BGA pad as possible is recommended. There are no power sequence requirements for the TS3DDR4000.

12 Layout

12.1 Layout Guidelines

Standard layout technique for 0.5 mm pitch BGA package shall be employed. The following commonly-used printed-circuit-board (PCB) layout guidelines are recommended:

- Use Non-Solder-Mask-Defined (NSMD), rather than Solder-Mask-Defined (SMD) pads for the BGA solder balls to adhere if possible. For most applications, the NSMD pads provide more flexibility, fewer stress.

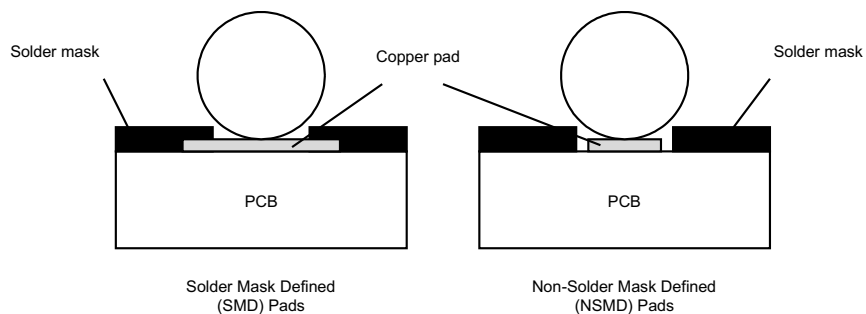
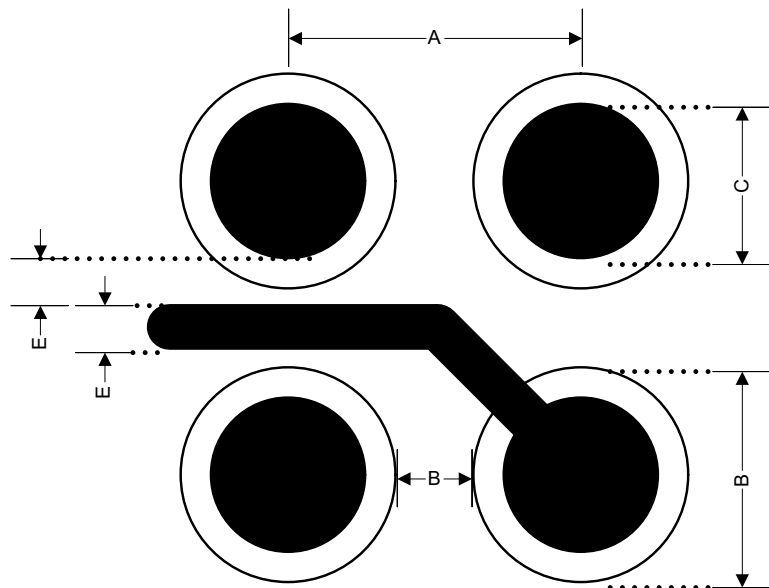

Figure 21. Solder-Mask-Defined (SMD) and Non-Solder-Mask-Defined (NSMD) Pads

- If NSMD pads are used, enough openings should be available for traces to be routed in between the solder pads with enough clearance. The following rules provides a good reference to layout the PCB:
 - Pad Pitch (A): 500 μm (~20 mils)
 - Pad Size (B): 250 μm (~10 mils)
 - Mask Shape: Round
 - Mask Opening (C): 50 μm around pad (350 μm anti-pad for the 250 mm pad)
 - Mask Web (D): 150 μm
 - Trace Allowed Between: Yes 3.2 mil trace maximum
 - Trace Width (E): 82 μm (~3.2 mil)
 - Pad to Trace Clearance (E): 82 μm (~3.2 mil)

Layout Guidelines (continued)

Figure 22. PCB Trace Example 1

- If a via is needed to go down to different layers, the following general rules can be used as a reference:
 - Pad Pitch: 500 μm
 - Pad Size: 250 μm (~10mils)
 - Via pad size (A): 254 μm
 - Pad to Via clearance (B): 72 μm
 - Pad to Via
 - Trace (C): 82 μm wide (~3.2 mil); 354 μm pad center to pad center
 - Via drill size (D): 127 μm (5 mil)

Layout Guidelines (continued)

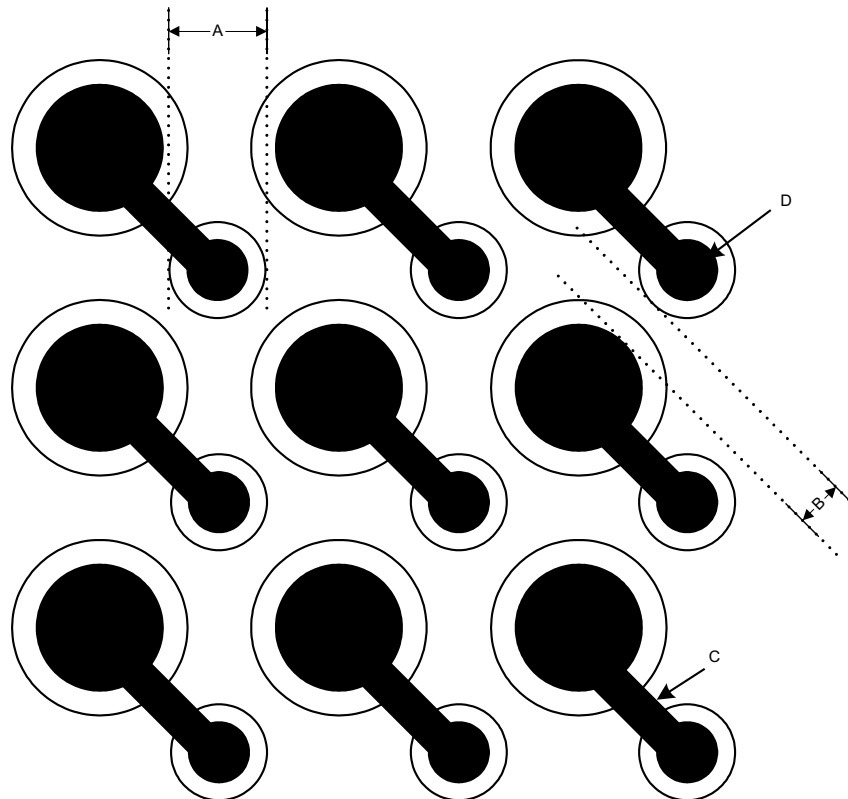

Figure 23. PCB Trace Example 2

- One trace can generally be routed between two solder pads of a 0.5 mm pitch BGA. This allows the outer two rows of solder pads to be routed on the same top/bottom layer. The TS3DDR4000 has 4 rows, and thus no VIAs is generally required to route all the inner balls out.
- Generally high-speed signal layout guidelines:
 - To minimize the effects of crosstalk on adjacent traces, keep the traces at least two times the trace width apart.
 - Separate high-speed signals from low-speed signals and digital from analog signals.
 - Avoid right-angle bends in a trace and try to route them at least with two 45° corners.
 - The high-speed differential signal traces should be routed parallel to each other as much as possible. The traces are recommended to be symmetrical.
 - A solid ground plane should be placed next to the high-speed signal layer. This also provides an excellent low-inductance path for the return current flow.

12.2 Layout Example

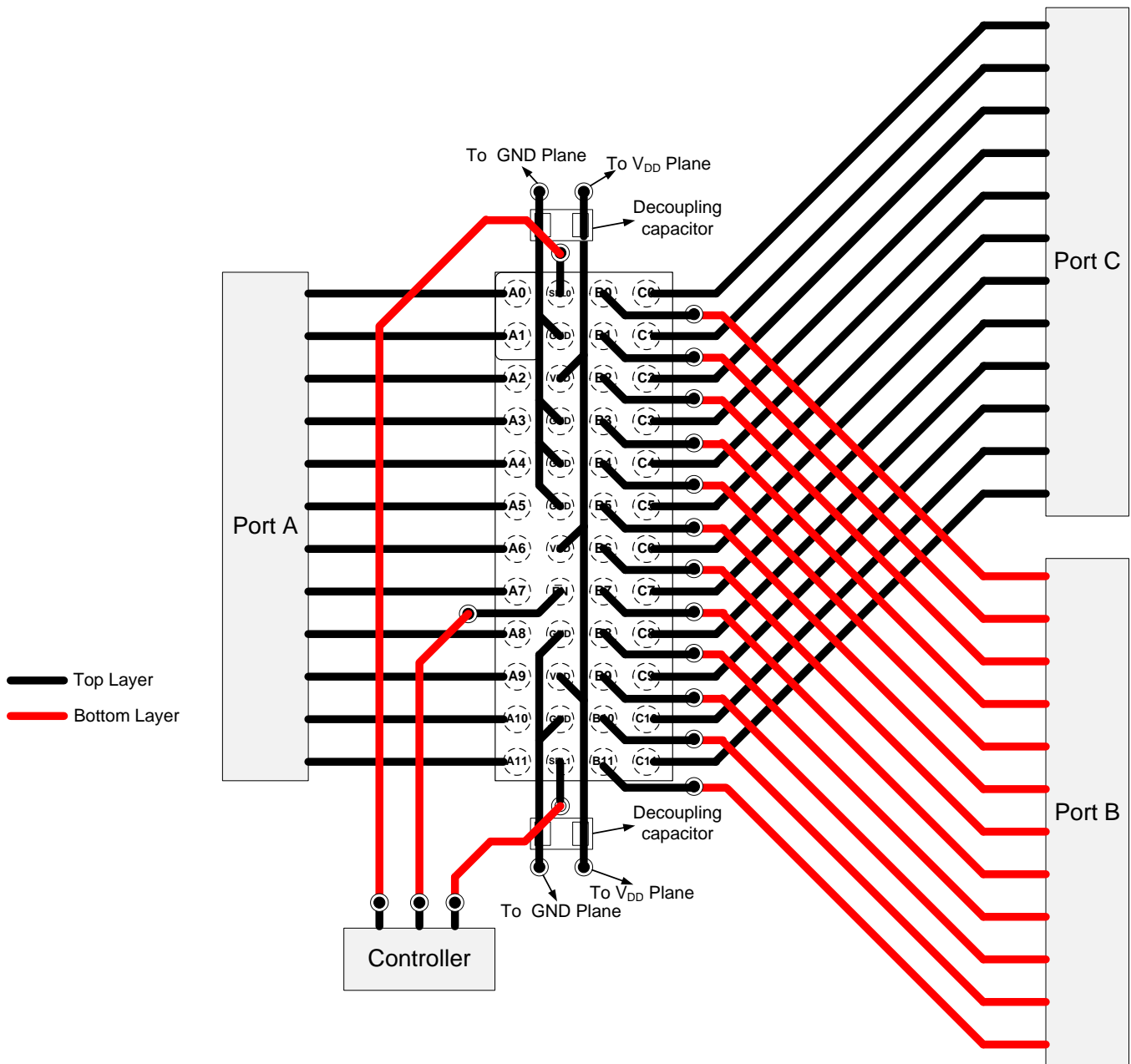

Figure 24. TS3DDR4000 Layout Example

13 Device and Documentation Support

13.1 Trademarks

All trademarks are the property of their respective owners.

13.2 Electrostatic Discharge Caution



These devices have limited built-in ESD protection. The leads should be shorted together or the device placed in conductive foam during storage or handling to prevent electrostatic damage to the MOS gates.

13.3 Glossary

[SLYZ022](#) — *TI Glossary*.

This glossary lists and explains terms, acronyms, and definitions.

14 Mechanical, Packaging, and Orderable Information

The following pages include mechanical, packaging, and orderable information. This information is the most current data available for the designated devices. This data is subject to change without notice and revision of this document. For browser-based versions of this data sheet, refer to the left-hand navigation.

PACKAGING INFORMATION

Orderable Device	Status (1)	Package Type	Package Drawing	Pins	Package Qty	Eco Plan (2)	Lead/Ball Finish (6)	MSL Peak Temp (3)	Op Temp (°C)	Device Marking (4/5)	Samples
TS3DDR4000ZBAR	ACTIVE	NFBGA	ZBA	48	3000	Green (RoHS & no Sb/Br)	SNAGCU	Level-3-260C-168 HR	-40 to 85	DDR4000	Samples

(1) The marketing status values are defined as follows:

ACTIVE: Product device recommended for new designs.

LIFEBUY: TI has announced that the device will be discontinued, and a lifetime-buy period is in effect.

NRND: Not recommended for new designs. Device is in production to support existing customers, but TI does not recommend using this part in a new design.

PREVIEW: Device has been announced but is not in production. Samples may or may not be available.

OBSELETE: TI has discontinued the production of the device.

(2) Eco Plan - The planned eco-friendly classification: Pb-Free (RoHS), Pb-Free (RoHS Exempt), or Green (RoHS & no Sb/Br) - please check <http://www.ti.com/productcontent> for the latest availability information and additional product content details.

TBD: The Pb-Free/Green conversion plan has not been defined.

Pb-Free (RoHS): TI's terms "Lead-Free" or "Pb-Free" mean semiconductor products that are compatible with the current RoHS requirements for all 6 substances, including the requirement that lead not exceed 0.1% by weight in homogeneous materials. Where designed to be soldered at high temperatures, TI Pb-Free products are suitable for use in specified lead-free processes.

Pb-Free (RoHS Exempt): This component has a RoHS exemption for either 1) lead-based flip-chip solder bumps used between the die and package, or 2) lead-based die adhesive used between the die and leadframe. The component is otherwise considered Pb-Free (RoHS compatible) as defined above.

Green (RoHS & no Sb/Br): TI defines "Green" to mean Pb-Free (RoHS compatible), and free of Bromine (Br) and Antimony (Sb) based flame retardants (Br or Sb do not exceed 0.1% by weight in homogeneous material)

(3) MSL, Peak Temp. - The Moisture Sensitivity Level rating according to the JEDEC industry standard classifications, and peak solder temperature.

(4) There may be additional marking, which relates to the logo, the lot trace code information, or the environmental category on the device.

(5) Multiple Device Markings will be inside parentheses. Only one Device Marking contained in parentheses and separated by a "~" will appear on a device. If a line is indented then it is a continuation of the previous line and the two combined represent the entire Device Marking for that device.

(6) Lead/Ball Finish - Orderable Devices may have multiple material finish options. Finish options are separated by a vertical ruled line. Lead/Ball Finish values may wrap to two lines if the finish value exceeds the maximum column width.

Important Information and Disclaimer:The information provided on this page represents TI's knowledge and belief as of the date that it is provided. TI bases its knowledge and belief on information provided by third parties, and makes no representation or warranty as to the accuracy of such information. Efforts are underway to better integrate information from third parties. TI has taken and continues to take reasonable steps to provide representative and accurate information but may not have conducted destructive testing or chemical analysis on incoming materials and chemicals. TI and TI suppliers consider certain information to be proprietary, and thus CAS numbers and other limited information may not be available for release.

In no event shall TI's liability arising out of such information exceed the total purchase price of the TI part(s) at issue in this document sold by TI to Customer on an annual basis.

ZBA0048A

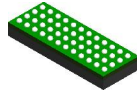

PACKAGE OUTLINE

NFBGA - 1.2 mm max height

BALL GRID ARRAY

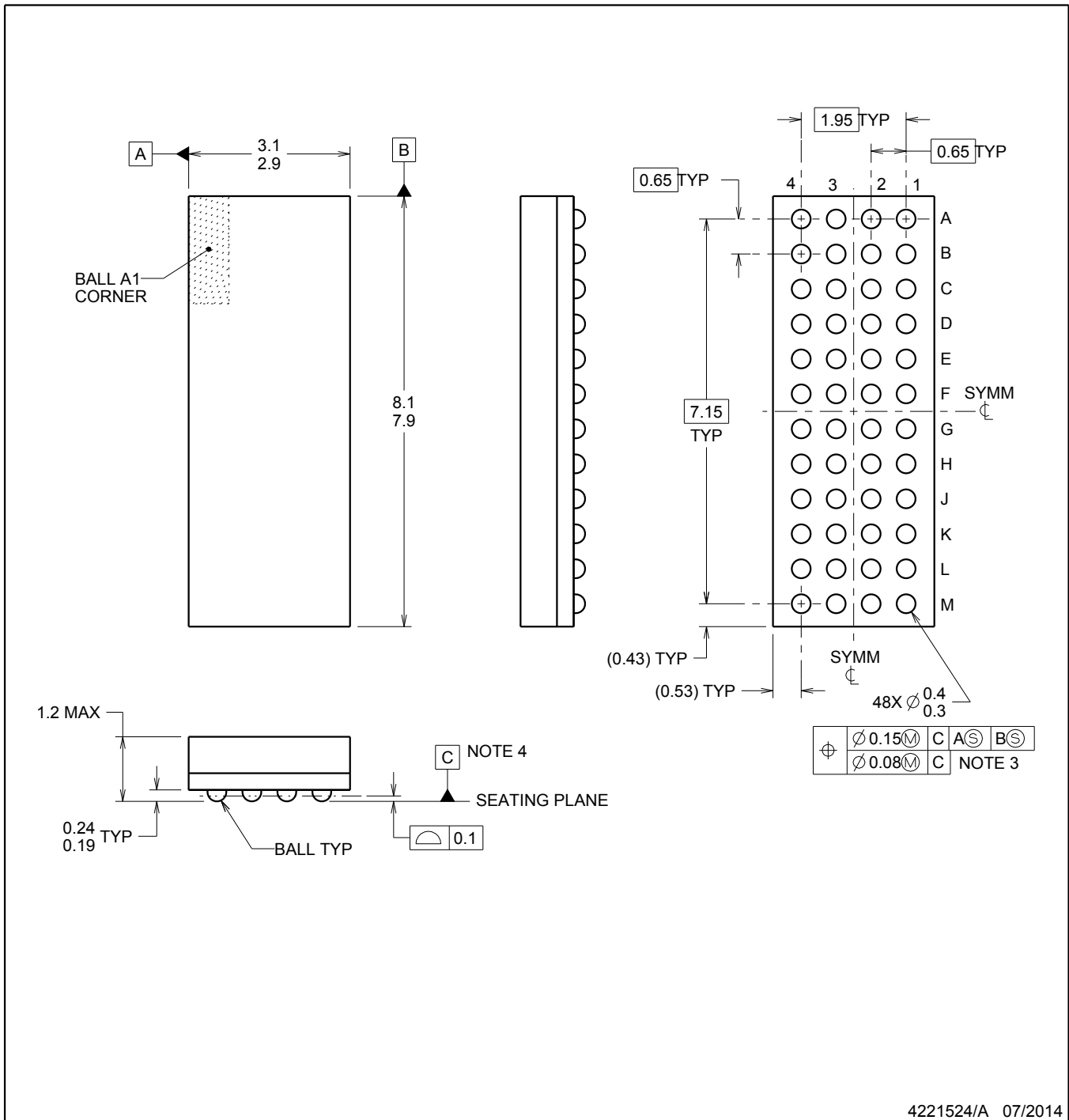

NOTES:

1. All linear dimensions are in millimeters. Any dimensions in parenthesis are for reference only. Dimensioning and tolerancing per ASME Y14.5M.
2. This drawing is subject to change without notice.
3. Dimension is measured at the maximum solder ball diameter, parallel to primary datum C.
4. Primary datum C and seating plane are defined by the spherical crowns of the solder balls.

EXAMPLE BOARD LAYOUT

ZBA0048A

NFBGA - 1.2 mm max height

BALL GRID ARRAY

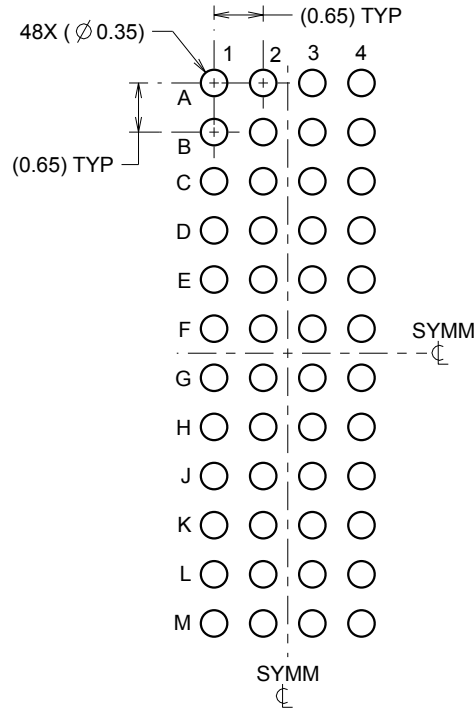

LAND PATTERN EXAMPLE
SCALE:10X

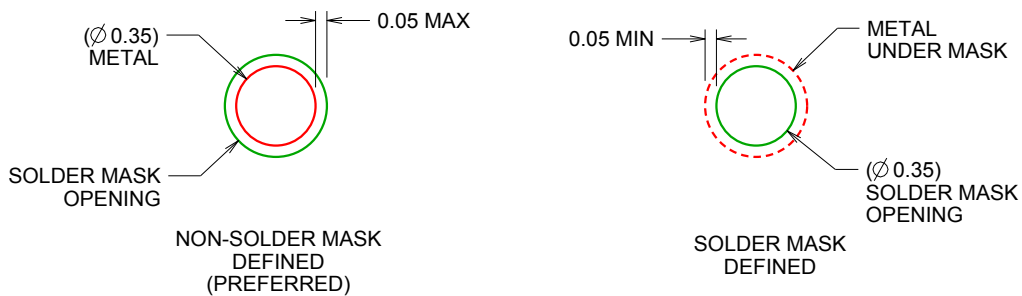

SOLDER MASK DETAILS
NOT TO SCALE

4221524/A 07/2014

NOTES: (continued)

- Final dimensions may vary due to manufacturing tolerance considerations and also routing constraints. For more information, see Texas Instruments Literature number SPRAA99 (www.ti.com/lit/spraa99).

EXAMPLE STENCIL DESIGN

ZBA0048A

NFBGA - 1.2 mm max height

BALL GRID ARRAY

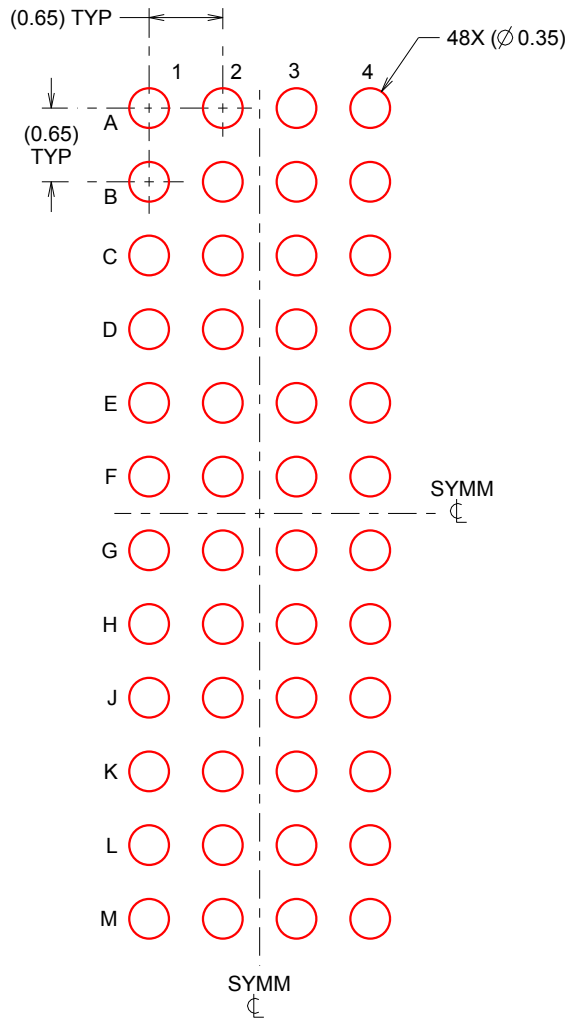

SOLDER PASTE EXAMPLE
BASED ON 0.125 mm THICK STENCIL
SCALE:15X

4221524/A 07/2014

NOTES: (continued)

6. Laser cutting apertures with trapezoidal walls and rounded corners may offer better paste release.

IMPORTANT NOTICE

Texas Instruments Incorporated and its subsidiaries (TI) reserve the right to make corrections, enhancements, improvements and other changes to its semiconductor products and services per JESD46, latest issue, and to discontinue any product or service per JESD48, latest issue. Buyers should obtain the latest relevant information before placing orders and should verify that such information is current and complete. All semiconductor products (also referred to herein as "components") are sold subject to TI's terms and conditions of sale supplied at the time of order acknowledgment.

TI warrants performance of its components to the specifications applicable at the time of sale, in accordance with the warranty in TI's terms and conditions of sale of semiconductor products. Testing and other quality control techniques are used to the extent TI deems necessary to support this warranty. Except where mandated by applicable law, testing of all parameters of each component is not necessarily performed.

TI assumes no liability for applications assistance or the design of Buyers' products. Buyers are responsible for their products and applications using TI components. To minimize the risks associated with Buyers' products and applications, Buyers should provide adequate design and operating safeguards.

TI does not warrant or represent that any license, either express or implied, is granted under any patent right, copyright, mask work right, or other intellectual property right relating to any combination, machine, or process in which TI components or services are used. Information published by TI regarding third-party products or services does not constitute a license to use such products or services or a warranty or endorsement thereof. Use of such information may require a license from a third party under the patents or other intellectual property of the third party, or a license from TI under the patents or other intellectual property of TI.

Reproduction of significant portions of TI information in TI data books or data sheets is permissible only if reproduction is without alteration and is accompanied by all associated warranties, conditions, limitations, and notices. TI is not responsible or liable for such altered documentation. Information of third parties may be subject to additional restrictions.

Resale of TI components or services with statements different from or beyond the parameters stated by TI for that component or service voids all express and any implied warranties for the associated TI component or service and is an unfair and deceptive business practice. TI is not responsible or liable for any such statements.

Buyer acknowledges and agrees that it is solely responsible for compliance with all legal, regulatory and safety-related requirements concerning its products, and any use of TI components in its applications, notwithstanding any applications-related information or support that may be provided by TI. Buyer represents and agrees that it has all the necessary expertise to create and implement safeguards which anticipate dangerous consequences of failures, monitor failures and their consequences, lessen the likelihood of failures that might cause harm and take appropriate remedial actions. Buyer will fully indemnify TI and its representatives against any damages arising out of the use of any TI components in safety-critical applications.

In some cases, TI components may be promoted specifically to facilitate safety-related applications. With such components, TI's goal is to help enable customers to design and create their own end-product solutions that meet applicable functional safety standards and requirements. Nonetheless, such components are subject to these terms.

No TI components are authorized for use in FDA Class III (or similar life-critical medical equipment) unless authorized officers of the parties have executed a special agreement specifically governing such use.

Only those TI components which TI has specifically designated as military grade or "enhanced plastic" are designed and intended for use in military/aerospace applications or environments. Buyer acknowledges and agrees that any military or aerospace use of TI components which have **not** been so designated is solely at the Buyer's risk, and that Buyer is solely responsible for compliance with all legal and regulatory requirements in connection with such use.

TI has specifically designated certain components as meeting ISO/TS16949 requirements, mainly for automotive use. In any case of use of non-designated products, TI will not be responsible for any failure to meet ISO/TS16949.

Products

Audio	www.ti.com/audio
Amplifiers	amplifier.ti.com
Data Converters	dataconverter.ti.com
DLP® Products	www.dlp.com
DSP	dsp.ti.com
Clocks and Timers	www.ti.com/clocks
Interface	interface.ti.com
Logic	logic.ti.com
Power Mgmt	power.ti.com
Microcontrollers	microcontroller.ti.com
RFID	www.ti-rfid.com
OMAP Applications Processors	www.ti.com/omap
Wireless Connectivity	www.ti.com/wirelessconnectivity

Applications

Automotive and Transportation	www.ti.com/automotive
Communications and Telecom	www.ti.com/communications
Computers and Peripherals	www.ti.com/computers
Consumer Electronics	www.ti.com/consumer-apps
Energy and Lighting	www.ti.com/energy
Industrial	www.ti.com/industrial
Medical	www.ti.com/medical
Security	www.ti.com/security
Space, Avionics and Defense	www.ti.com/space-avionics-defense
Video and Imaging	www.ti.com/video

TI E2E Community

e2e.ti.com