

TS321 Low-Power Single Operational Amplifier

1 Features

- Wide Power-Supply Range
 - Single Supply from 3 V to 30 V
 - Dual Supply from ± 1.5 V to ± 15 V
- Large Output Voltage Swing from 0 V to 3.5 V (Minimum) ($V_{CC} = 5$ V)
- Low Supply Current at 500 μ A (Typical)
- Low Input Bias Current at 20 nA (Typical)
- Stable With High Capacitive Loads

2 Applications

- Desktop PCs
- HVAC: Heating, Ventilating, and Air Conditioning
- Portable Media Players
- Refrigerators
- Washing Machines: High-End and Low-End

4 Device Pinouts

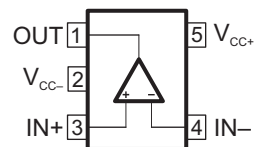
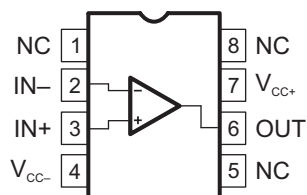

3 Description

The TS321 is a bipolar operational amplifier for cost-sensitive applications in which space savings are important.

Device Information⁽¹⁾

PART NUMBER	PACKAGE	BODY SIZE (NOM)
TS321	SOIC (14)	4.90 mm x 3.90 mm
	SOT-23 (5)	2.90 mm x 1.60 mm

(1) For all available packages, see the orderable addendum at the end of the datasheet.



Table of Contents

1 Features	1	8.2 Functional Block Diagram	7
2 Applications	1	8.3 Feature Description.....	7
3 Description	1	8.4 Device Functional Modes.....	8
4 Device Pinouts	1	9 Application and Implementation	9
5 Revision History	2	9.1 Application Information.....	9
6 Pin Configuration and Functions	3	9.2 Typical Application	9
7 Specifications	4	10 Power Supply Recommendations	10
7.1 Absolute Maximum Ratings	4	11 Layout	10
7.2 ESD Ratings.....	4	11.1 Layout Guidelines	10
7.3 Recommended Operating Conditions	4	11.2 Layout Example	11
7.4 Thermal Information	4	12 Device and Documentation Support	12
7.5 Electrical Characteristics.....	5	12.1 Documentation Support	12
7.6 Typical Characteristics.....	6	12.2 Trademarks	12
8 Detailed Description	7	12.3 Electrostatic Discharge Caution.....	12
8.1 Overview	7	12.4 Glossary	12

5 Revision History

Changes from Revision B (December 2013) to Revision C	Page
<ul style="list-style-type: none"> Added <i>Pin Configuration and Functions</i> section, <i>ESD Ratings</i> table, <i>Feature Description</i> section, <i>Device Functional Modes</i>, <i>Application and Implementation</i> section, <i>Power Supply Recommendations</i> section, <i>Layout</i> section, <i>Device and Documentation Support</i> section, and <i>Mechanical, Packaging, and Orderable Information</i> section 	1
<ul style="list-style-type: none"> Changed V_{OL} units typo from V to mV..... 	5

6 Pin Configuration and Functions

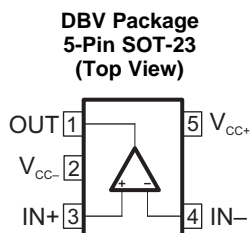
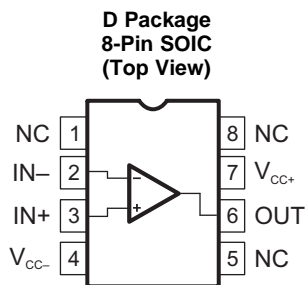

Pin Functions

NAME	PIN		I/O	DESCRIPTION
	SOIC NO.	SOT-23 NO.		
IN-	2	4	I	Negative input
IN+	3	3	I	Positive input
NC ⁽¹⁾	1	—	—	Do not connect
	5			
	8			
OUT	6	1	O	Output
V _{CC-}	4	2	—	Negative supply
V _{CC+}	7	5	—	Positive supply

(1) NC – No internal connection

7 Specifications

7.1 Absolute Maximum Ratings

over operating free-air temperature range (unless otherwise noted)⁽¹⁾

		MIN	MAX	UNIT
V _{CC}	Supply voltage	Single Supply	32	V
		Dual Supplies	±16	
V _{ID}	Differential input voltage ⁽²⁾		±32	V
V _I	Input voltage range ⁽³⁾	-0.3	32	V
I _{IK}	Input current		50	mA
t _{short}	Duration of output short circuit to ground		Unlimited	
T _J	Operating virtual junction temperature		150	°C
T _{stg}	Storage temperature	-65	150	°C

- (1) Stresses beyond those listed under *Absolute Maximum Ratings* may cause permanent damage to the device. These are stress ratings only, and functional operation of the device at these or any other conditions beyond those indicated under *Recommended Operating Conditions* is not implied. Exposure to absolute-maximum-rated conditions for extended periods may affect device reliability.
- (2) Differential voltages are at IN+ with respect to IN-.
- (3) Input voltages are at IN with respect to V_{CC-}.

7.2 ESD Ratings

		VALUE	UNIT
V _(ESD)	Electrostatic discharge	Human-body model (HBM), per ANSI/ESDA/JEDEC JS-001 ⁽¹⁾	±2500
		Charged-device model (CDM), per JEDEC specification JESD22-C101 ⁽²⁾	±1500

- (1) JEDEC document JEP155 states that 500-V HBM allows safe manufacturing with a standard ESD control process.
- (2) JEDEC document JEP157 states that 250-V CDM allows safe manufacturing with a standard ESD control process.

7.3 Recommended Operating Conditions

		MIN	MAX	UNIT
V _{CC}	Supply voltage	Single supply	3	V
		Dual supply	±1.5	
T _A	Operating free-air temperature	-40	125	°C

7.4 Thermal Information

THERMAL METRIC ⁽¹⁾	TS321		UNIT	
	D (SOIC)	DBV (SOT-23)		
	5 PIN	5 PIN		
R _{θJA}	Junction-to-ambient thermal resistance ⁽²⁾⁽³⁾	97	206	°C/W

- (1) For more information about traditional and new thermal metrics, see the *IC Package Thermal Metrics* application report, [SPRA953](#).
- (2) Maximum power dissipation is a function of T_{J(max)}, q_{JA}, and T_A. The maximum allowable power dissipation at any allowable ambient temperature is PD = (T_{J(max)} - T_A)/q_{JA}. Selecting the maximum of 150°C can affect reliability.
- (3) The package thermal impedance is calculated in accordance with JESD 51-7.

7.5 Electrical Characteristics

 $V_{CC+} = 5\text{ V}$, $V_{CC-} = \text{GND}$, $V_O = 1.4\text{ V}$ (unless otherwise noted)

PARAMETER		TEST CONDITIONS		T_A	MIN	TYP	MAX	UNIT
V_{IO}	Input offset voltage	$R_S = 0$, $5\text{ V} < V_{CC+} < 30\text{ V}$, $0 < V_{IC} < (V_{CC+} - 1.5\text{ V})$		25°C		0.5	4	mV
				Full range			5	
I_{IO}	Input offset current			25°C		2	30	nA
				Full range			50	
I_{IB}	Input bias current ⁽¹⁾			25°C		20	150	nA
				Full range			200	
A_{VD}	Large-signal differential voltage amplification	$V_{CC} = 15\text{ V}$, $R_L = 2\text{ k}\Omega$, $V_O = 1.4\text{ V}$ to 11.4 V		25°C	50	100		V/mV
				Full range	25			
V_{ICR}	Common-mode input voltage ⁽²⁾	$V_{CC} = 30\text{ V}$		25°C	0		$V_{CC+} - 1.5$	V
				Full range	0		$V_{CC+} - 2$	
V_{OH}	High-level output voltage	$V_{CC} = 30\text{ V}$	$R_L = 2\text{ k}\Omega$	25°C	26	27		V
				Full range	25.5			
			$R_L = 10\text{ k}\Omega$	25°C	27	28		
				Full range	26.5			
		$V_{CC} = 5\text{ V}$	$R_L = 2\text{ k}\Omega$	25°C	3.5			
				Full range	3			
V_{OL}	Low-level output voltage	$R_L = 10\text{ k}\Omega$		25°C		5	15	mV
				Full range			20	
GBP	Gain bandwidth product	$V_{CC} = 30\text{ V}$, $V_I = 10\text{ mV}$, $R_L = 2\text{ k}\Omega$, $f = 100\text{ kHz}$, $C_L = 100\text{ pF}$		25°C		0.8		MHz
SR	Slew rate	$V_{CC} = 15\text{ V}$, $V_I = 0.5\text{ V}$ to 3 V , $R_L = 2\text{ k}\Omega$, $C_L = 100\text{ pF}$, unity gain		25°C		0.4		V/ μs
Φ_m	Phase margin			25°C		60		°
CMRR	Common-mode rejection ratio	$R_S \leq 10\text{ k}\Omega$		25°C	65	85		dB
I_{SOURCE}	Output source current	$V_{CC} = 15\text{ V}$, $V_O = 2\text{ V}$, $V_{ID} = 1\text{ V}$		25°C	20	40		mA
I_{SINK}	Output sink current	$V_{CC} = 15\text{ V}$, $V_{ID} = 1\text{ V}$		$V_O = 2\text{ V}$	25°C	10	20	mA
				$V_O = 0.2\text{ V}$	25°C	12	50	μA
I_O	Short-circuit to GND	$V_{CC} = 15\text{ V}$		25°C		40	60	mA
SVR	Supply-voltage rejection ratio	$V_{CC} = 5\text{ V}$ to 30 V		25°C	65	110		dB
I_{CC}	Total supply current	No load		25°C	$V_{CC} = 5\text{ V}$	500	800	μA
					$V_{CC} = 30\text{ V}$	600	900	
				Full range	$V_{CC} = 5\text{ V}$	600	900	
					$V_{CC} = 30\text{ V}$		1000	
THD	Total harmonic distortion	$V_{CC} = 30\text{ V}$, $V_O = 2\text{ V}_{pp}$, $A_V = 20\text{ dB}$, $R_L = 2\text{ k}\Omega$, $f = 1\text{ kHz}$, $C_L = 100\text{ pF}$		25°C		0.015%		
e_N	Equivalent input noise voltage	$V_{CC} = 30\text{ V}$, $f = 1\text{ kHz}$, $R_S = 100\ \Omega$		25°C		50		nV/ $\sqrt{\text{Hz}}$

- (1) The direction of the input current is out of the device. This current essentially is constant, independent of the state of the output, so no loading change exists on the input lines.
- (2) The input common-mode voltage of either input signal should not be allowed to go negative by more than 0.3 V. The upper end of the common-mode voltage range is $V_{CC+} - 1.5\text{ V}$, but either or both inputs can go to 32 V without damage.

7.6 Typical Characteristics

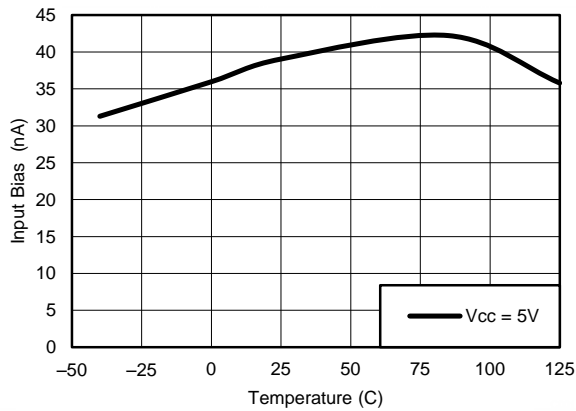

Figure 1. Input Current vs Temperature

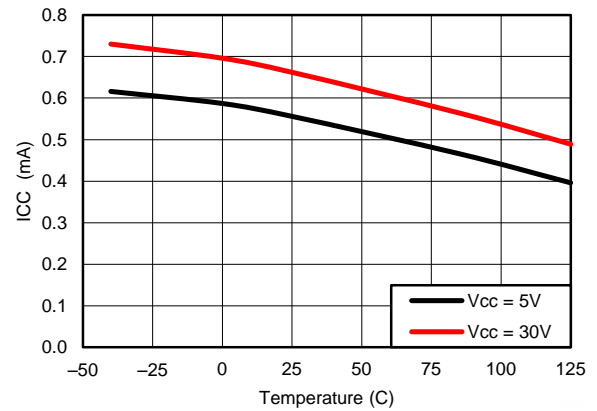

Figure 2. Supply Current vs Temperature

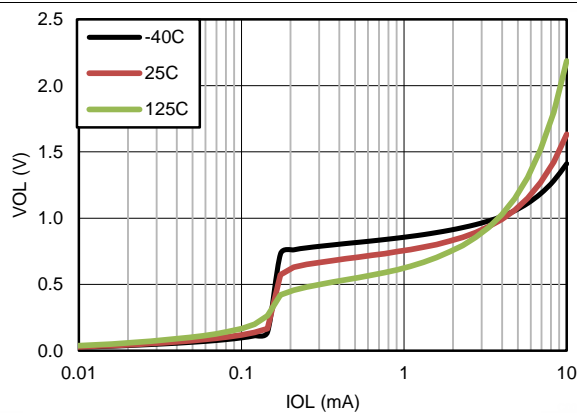

Figure 3. Output Sinking Characteristics

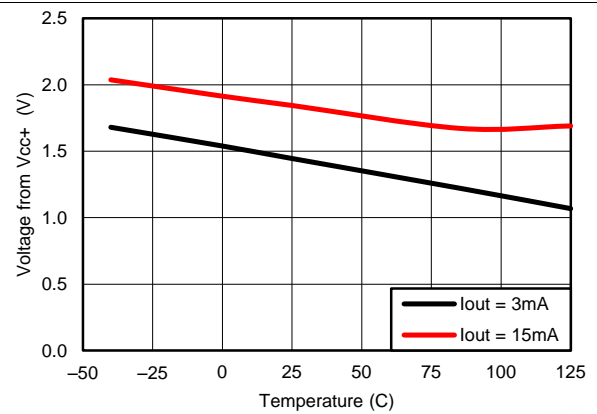

Figure 4. Output Sourcing Characteristics

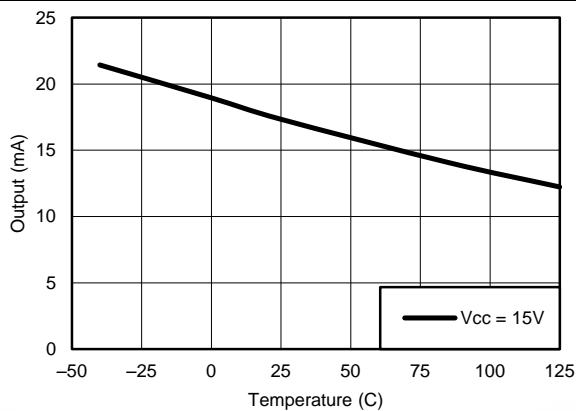

Figure 5. Short Circuit Current to Supply ⁽¹⁾

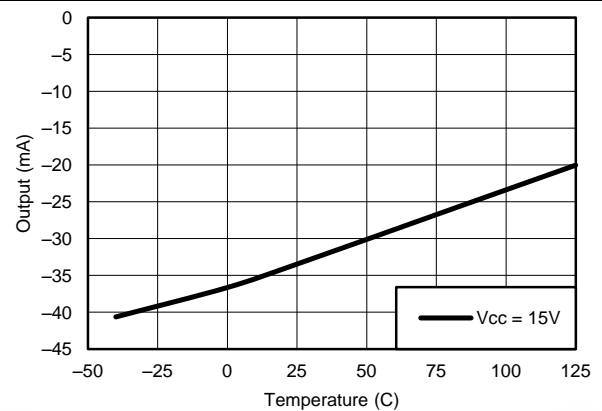

Figure 6. Short Circuit Current to Ground

(1) Short circuits from outputs to VCC can cause excessive heating and eventual destruction.

8 Detailed Description

8.1 Overview

The TS321 is a single-channel operational amplifier. It can handle a single supply between 3 V and 30 V or a dual-supply between ± 1.5 V and ± 15 V. Available in the small SOT-23 package, the TS321 is great for saving space in any application.

8.2 Functional Block Diagram

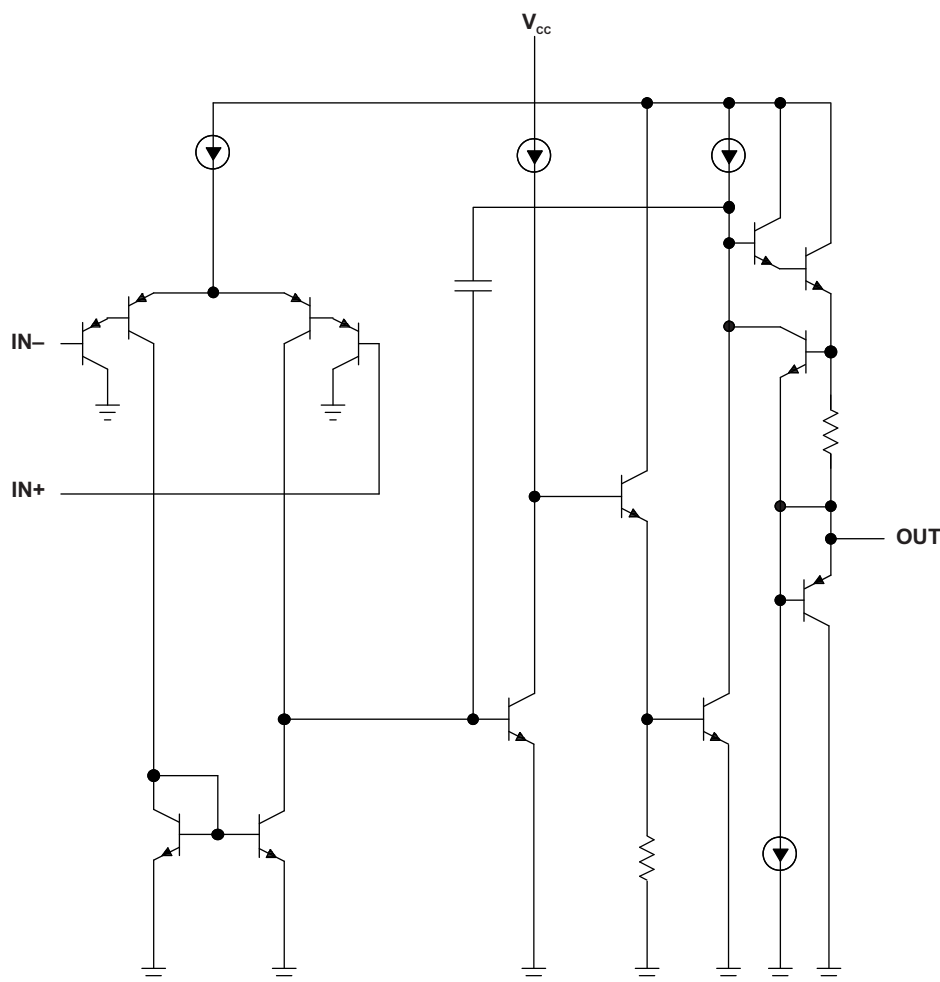

8.3 Feature Description

8.3.1 Operating Voltage

The TS321 can be powered from a single supply between 3 V and 30 V or a dual-supply between ± 1.5 V and ± 15 V.

8.3.2 Gain Bandwidth Product

Gain bandwidth product is found by multiplying an amplifier's measured bandwidth by the gain at which that bandwidth was measured. The TS321 has a gain bandwidth of 0.8 MHz.

8.3.3 Slew Rate

The slew rate is the rate at which an operational amplifier can change its output when there is a change on the input. The TS321 has a 0.4-V/ μ s slew rate.

Feature Description (continued)

8.3.4 Input Common Mode Range

The valid common mode range is from device ground pin to $V_{CC} - 1.5\text{ V}$ ($V_{CC} - 2\text{ V}$ across temperature). Inputs may exceed V_{CC} up to the maximum V_{CC} without device damage. At least one input must be in the valid input common mode range for output to be correct phase. If both inputs exceed valid range then output phase is undefined. If either input is less than -0.3 V then input current should be limited to 1 mA and output phase is undefined.

8.3.5 Stability With High Capacitive Loads

Operational amplifiers have reduced phase margin when there is a direct capacitance on the output. The stability is affected most when the amplifier is set to unity gain. Small signal response to a step input of 100 mV reveals the loop stability with a range of capacitors. See application note [SLVA381](#) to correlate response waveform to phase margin. The responses at 1 nF or less indicate acceptable phase margin. The responses at $1\text{ }\mu\text{F}$ and above indicate good phase margin.

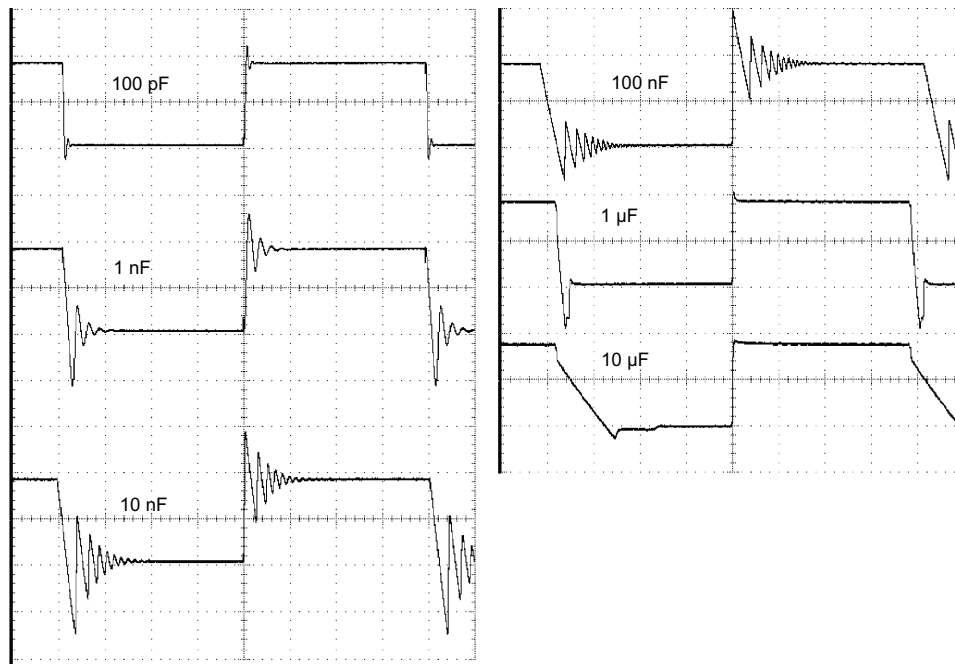

Figure 7. Small Signal Response

8.4 Device Functional Modes

The TS321 is powered on when the supply is connected. This device can be operated as a single supply operational amplifier or dual supply amplifier depending on the application.

9 Application and Implementation

NOTE

Information in the following applications sections is not part of the TI component specification, and TI does not warrant its accuracy or completeness. TI's customers are responsible for determining suitability of components for their purposes. Customers should validate and test their design implementation to confirm system functionality.

9.1 Application Information

The TS321 operational amplifier is useful in a wide range of signal conditioning applications. Inputs can be powered before VCC for flexibility in multiple supply circuits.

9.2 Typical Application

A typical application for an operational amplifier in an inverting amplifier. This amplifier takes a positive voltage on the input, and makes it a negative voltage of the same magnitude. In the same manner, it also makes negative voltages positive.

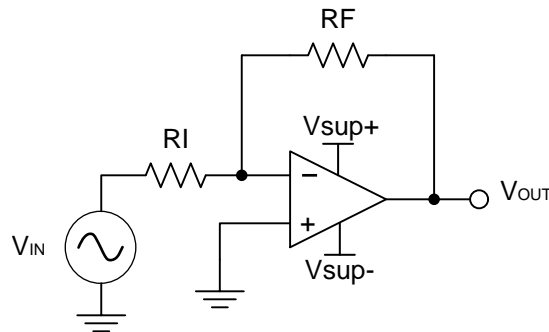

Figure 8. Typical Application Schematic

9.2.1 Design Requirements

The supply voltage must be chosen such that it is larger than the input voltage range and output range. For instance, this application will scale a signal of ± 0.5 V to ± 1.8 V. Setting the supply at ± 12 V is sufficient to accommodate this application.

9.2.2 Detailed Design Procedure

Determine the gain required by the inverting amplifier:

$$A_v = \frac{V_{OUT}}{V_{IN}} \quad (1)$$

$$A_v = \frac{1.8}{-0.5} = -3.6 \quad (2)$$

Once the desired gain is determined, choose a value for R_I or R_F . Choosing a value in the kilohm range is desirable because the amplifier circuit will use currents in the milliamp range. This ensures the part will not draw too much current. This example will choose 10 k Ω for R_I which means 36 k Ω will be used for R_F . This was determined by Equation 3.

$$A_v = -\frac{R_F}{R_I} \quad (3)$$

Typical Application (continued)

9.2.3 Application Curve

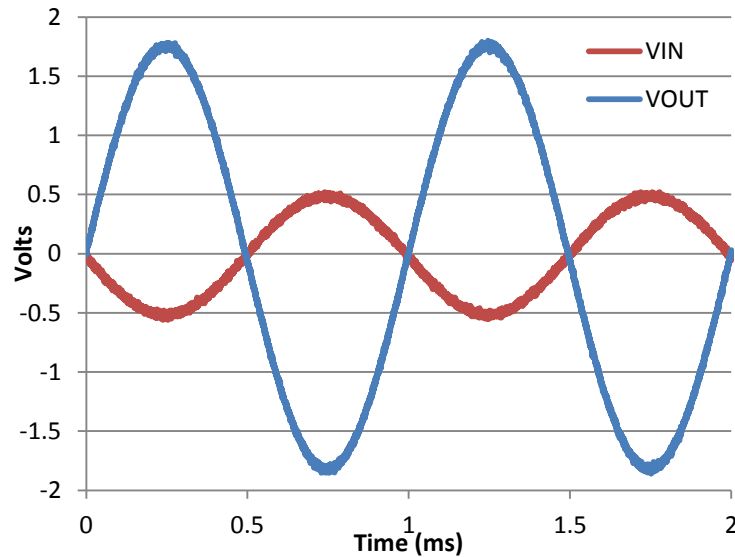

Figure 9. Input and output voltages of the inverting amplifier

10 Power Supply Recommendations

The TS321 is specified to operate between 3 V and 30 V or a dual supply between ± 1.5 V and ± 15 V.

CAUTION

Supply voltages larger than 32 V for a single supply, or outside the range of ± 16 V for a dual supply can permanently damage the device (see the [Absolute Maximum Ratings](#)).

Place 0.1- μ F bypass capacitors close to the power-supply pins to reduce errors coupling in from noisy or high impedance power supplies. For more detailed information on bypass capacitor placement, refer to the [Layout](#).

11 Layout

11.1 Layout Guidelines

For best operational performance of the device, use good PCB layout practices, including:

- Noise can propagate into analog circuitry through the power pins of the circuit as a whole, as well as the operational amplifier. Bypass capacitors are used to reduce the coupled noise by providing low impedance power sources local to the analog circuitry.
 - Connect low-ESR, 0.1- μ F ceramic bypass capacitors between each supply pin and ground, placed as close to the device as possible. A single bypass capacitor from V+ to ground is applicable for single supply applications.
- Separate grounding for analog and digital portions of circuitry is one of the simplest and most-effective methods of noise suppression. One or more layers on multilayer PCBs are usually devoted to ground planes. A ground plane helps distribute heat and reduces EMI noise pickup. Make sure to physically separate digital and analog grounds, paying attention to the flow of the ground current. For more detailed information, refer to application note [SLOA089](#).
- To reduce parasitic coupling, run the input traces as far away from the supply or output traces as possible. If it is not possible to keep them separate, it is much better to cross the sensitive trace perpendicular as

Layout Guidelines (continued)

- opposed to in parallel with the noisy trace.
- Place the external components as close to the device as possible. Keeping R_F and R_G close to the inverting input minimizes parasitic capacitance, as shown in [Layout Example](#).
- Keep the length of input traces as short as possible. Always remember that the input traces are the most sensitive part of the circuit.
- Consider a driven, low-impedance guard ring around the critical traces. A guard ring can significantly reduce leakage currents from nearby traces that are at different potentials.

11.2 Layout Example

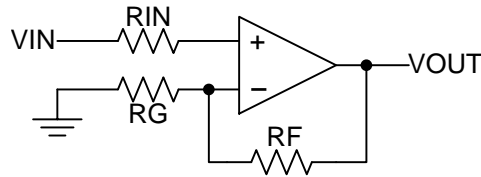

Figure 10. Operational Amplifier Schematic for Noninverting Configuration

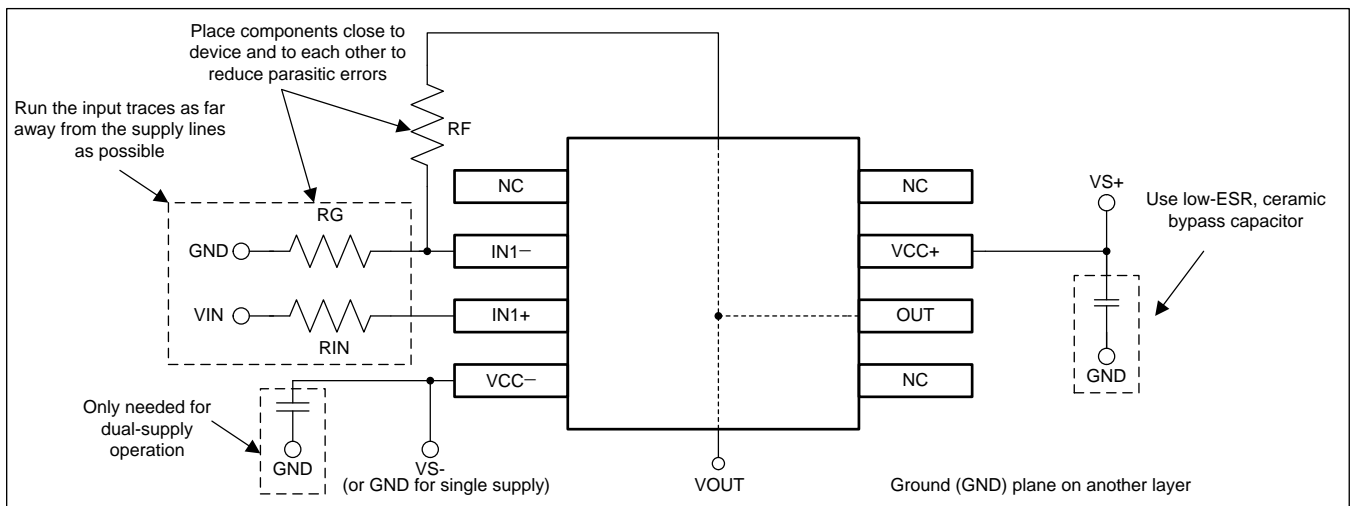

Figure 11. Operational Amplifier Board Layout for Noninverting Configuration

12 Device and Documentation Support

12.1 Documentation Support

12.1.1 Related Documentation

For more information, see the following:

- *Simplifying Stability Checks*, [SLVA381](#)
- *Circuit Board Layout Techniques*, [SLOA089](#)

12.2 Trademarks

All trademarks are the property of their respective owners.

12.3 Electrostatic Discharge Caution



These devices have limited built-in ESD protection. The leads should be shorted together or the device placed in conductive foam during storage or handling to prevent electrostatic damage to the MOS gates.

12.4 Glossary

[SLYZ022](#) — *TI Glossary*.

This glossary lists and explains terms, acronyms, and definitions.

PACKAGING INFORMATION

Orderable Device	Status (1)	Package Type	Package Drawing	Pins	Package Qty	Eco Plan (2)	Lead/Ball Finish (6)	MSL Peak Temp (3)	Op Temp (°C)	Device Marking (4/5)	Samples
TS321ID	ACTIVE	SOIC	D	8	75	Green (RoHS & no Sb/Br)	CU NIPDAU	Level-1-260C-UNLIM	-40 to 125	SR321I	Samples
TS321IDBVR	ACTIVE	SOT-23	DBV	5	3000	Green (RoHS & no Sb/Br)	CU NIPDAU	Level-1-260C-UNLIM	-40 to 125	(9C1G ~ 9C1S)	Samples
TS321IDBvre4	ACTIVE	SOT-23	DBV	5	3000	Green (RoHS & no Sb/Br)	CU NIPDAU	Level-1-260C-UNLIM	-40 to 125	9C1G	Samples
TS321IDBVRG4	ACTIVE	SOT-23	DBV	5	3000	Green (RoHS & no Sb/Br)	CU NIPDAU	Level-1-260C-UNLIM	-40 to 125	9C1G	Samples
TS321IDBVT	ACTIVE	SOT-23	DBV	5	250	Green (RoHS & no Sb/Br)	CU NIPDAU	Level-1-260C-UNLIM	-40 to 125	(9C1G ~ 9C1S)	Samples
TS321IDR	ACTIVE	SOIC	D	8	2500	Green (RoHS & no Sb/Br)	CU NIPDAU	Level-1-260C-UNLIM	-40 to 125	SR321I	Samples

(1) The marketing status values are defined as follows:

ACTIVE: Product device recommended for new designs.

LIFEBUY: TI has announced that the device will be discontinued, and a lifetime-buy period is in effect.

NRND: Not recommended for new designs. Device is in production to support existing customers, but TI does not recommend using this part in a new design.

PREVIEW: Device has been announced but is not in production. Samples may or may not be available.

OBSELETE: TI has discontinued the production of the device.

(2) Eco Plan - The planned eco-friendly classification: Pb-Free (RoHS), Pb-Free (RoHS Exempt), or Green (RoHS & no Sb/Br) - please check <http://www.ti.com/productcontent> for the latest availability information and additional product content details.

TBD: The Pb-Free/Green conversion plan has not been defined.

Pb-Free (RoHS): TI's terms "Lead-Free" or "Pb-Free" mean semiconductor products that are compatible with the current RoHS requirements for all 6 substances, including the requirement that lead not exceed 0.1% by weight in homogeneous materials. Where designed to be soldered at high temperatures, TI Pb-Free products are suitable for use in specified lead-free processes.

Pb-Free (RoHS Exempt): This component has a RoHS exemption for either 1) lead-based flip-chip solder bumps used between the die and package, or 2) lead-based die adhesive used between the die and leadframe. The component is otherwise considered Pb-Free (RoHS compatible) as defined above.

Green (RoHS & no Sb/Br): TI defines "Green" to mean Pb-Free (RoHS compatible), and free of Bromine (Br) and Antimony (Sb) based flame retardants (Br or Sb do not exceed 0.1% by weight in homogeneous material)

(3) MSL, Peak Temp. - The Moisture Sensitivity Level rating according to the JEDEC industry standard classifications, and peak solder temperature.

(4) There may be additional marking, which relates to the logo, the lot trace code information, or the environmental category on the device.

(5) Multiple Device Markings will be inside parentheses. Only one Device Marking contained in parentheses and separated by a "~" will appear on a device. If a line is indented then it is a continuation of the previous line and the two combined represent the entire Device Marking for that device.

⁽⁶⁾ Lead/Ball Finish - Orderable Devices may have multiple material finish options. Finish options are separated by a vertical ruled line. Lead/Ball Finish values may wrap to two lines if the finish value exceeds the maximum column width.

Important Information and Disclaimer:The information provided on this page represents TI's knowledge and belief as of the date that it is provided. TI bases its knowledge and belief on information provided by third parties, and makes no representation or warranty as to the accuracy of such information. Efforts are underway to better integrate information from third parties. TI has taken and continues to take reasonable steps to provide representative and accurate information but may not have conducted destructive testing or chemical analysis on incoming materials and chemicals. TI and TI suppliers consider certain information to be proprietary, and thus CAS numbers and other limited information may not be available for release.

In no event shall TI's liability arising out of such information exceed the total purchase price of the TI part(s) at issue in this document sold by TI to Customer on an annual basis.

OTHER QUALIFIED VERSIONS OF TS321 :

- Automotive: [TS321-Q1](#)

NOTE: Qualified Version Definitions:

- Automotive - Q100 devices qualified for high-reliability automotive applications targeting zero defects

TAPE AND REEL INFORMATION



QUADRANT ASSIGNMENTS FOR PIN 1 ORIENTATION IN TAPE



*All dimensions are nominal

Device	Package Type	Package Drawing	Pins	SPQ	Reel Diameter (mm)	Reel Width W1 (mm)	A0 (mm)	B0 (mm)	K0 (mm)	P1 (mm)	W (mm)	Pin1 Quadrant
TS321IDBVR	SOT-23	DBV	5	3000	178.0	9.0	3.23	3.17	1.37	4.0	8.0	Q3
TS321IDBVRG4	SOT-23	DBV	5	3000	178.0	9.0	3.23	3.17	1.37	4.0	8.0	Q3
TS321IDBVT	SOT-23	DBV	5	250	178.0	9.0	3.23	3.17	1.37	4.0	8.0	Q3
TS321IDR	SOIC	D	8	2500	330.0	12.4	6.4	5.2	2.1	8.0	12.0	Q1

TAPE AND REEL BOX DIMENSIONS

*All dimensions are nominal

Device	Package Type	Package Drawing	Pins	SPQ	Length (mm)	Width (mm)	Height (mm)
TS321IDBVR	SOT-23	DBV	5	3000	180.0	180.0	18.0
TS321IDBVRG4	SOT-23	DBV	5	3000	180.0	180.0	18.0
TS321IDBVT	SOT-23	DBV	5	250	180.0	180.0	18.0
TS321IDR	SOIC	D	8	2500	340.5	338.1	20.6

DBV (R-PDSO-G5)

PLASTIC SMALL-OUTLINE PACKAGE



- NOTES:
- A. All linear dimensions are in millimeters.
 - B. This drawing is subject to change without notice.
 - C. Body dimensions do not include mold flash or protrusion. Mold flash and protrusion shall not exceed 0.15 per side.
 - D. Falls within JEDEC MO-178 Variation AA.

DBV (R-PDSO-G5)

PLASTIC SMALL OUTLINE



- NOTES:
- A. All linear dimensions are in millimeters.
 - B. This drawing is subject to change without notice.
 - C. Customers should place a note on the circuit board fabrication drawing not to alter the center solder mask defined pad.
 - D. Publication IPC-7351 is recommended for alternate designs.
 - E. Laser cutting apertures with trapezoidal walls and also rounding corners will offer better paste release. Customers should contact their board assembly site for stencil design recommendations. Example stencil design based on a 50% volumetric metal load solder paste. Refer to IPC-7525 for other stencil recommendations.

D (R-PDSO-G8)

PLASTIC SMALL OUTLINE

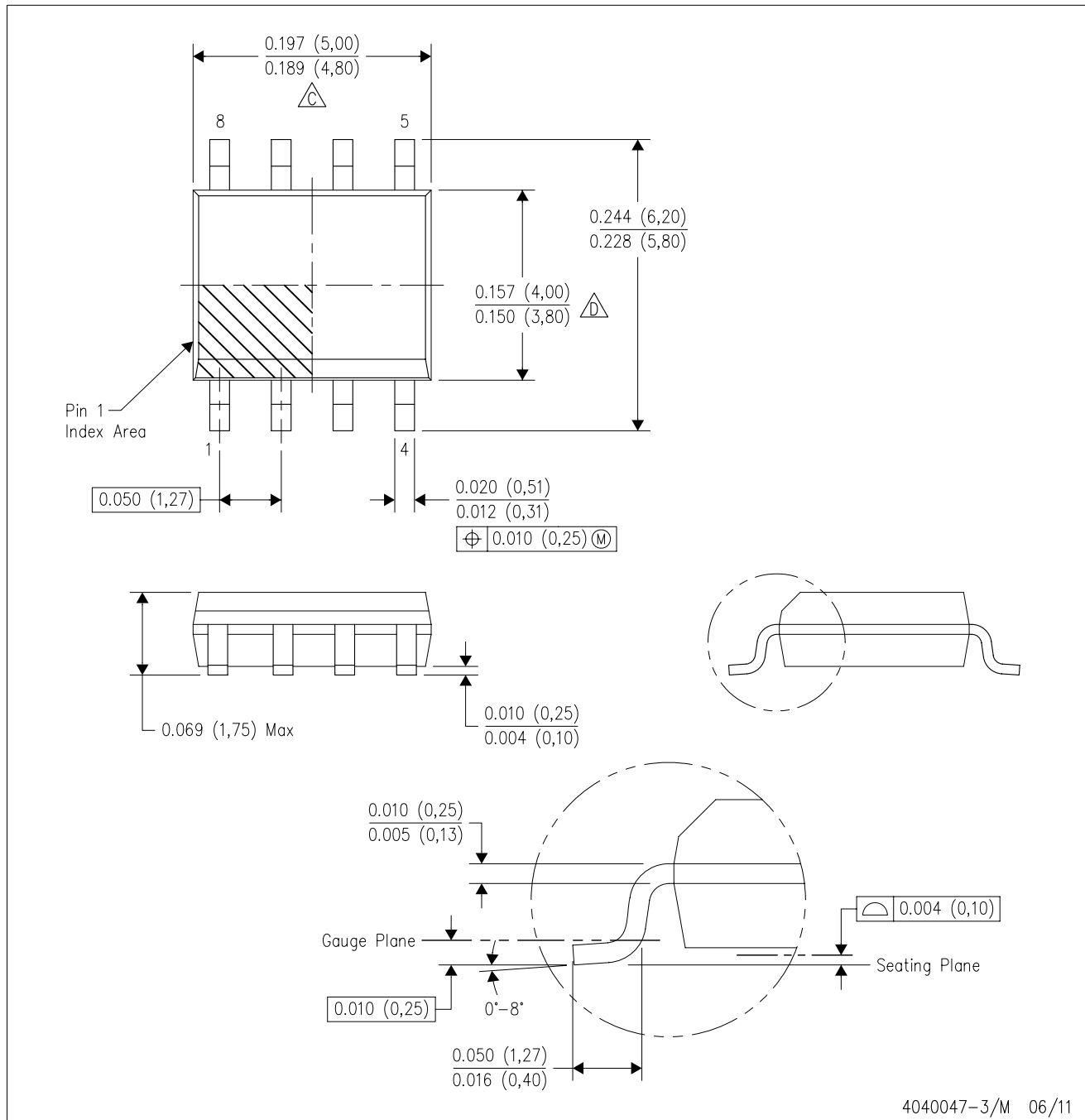

4040047-3/M 06/11

D (R-PDSO-G8)

PLASTIC SMALL OUTLINE

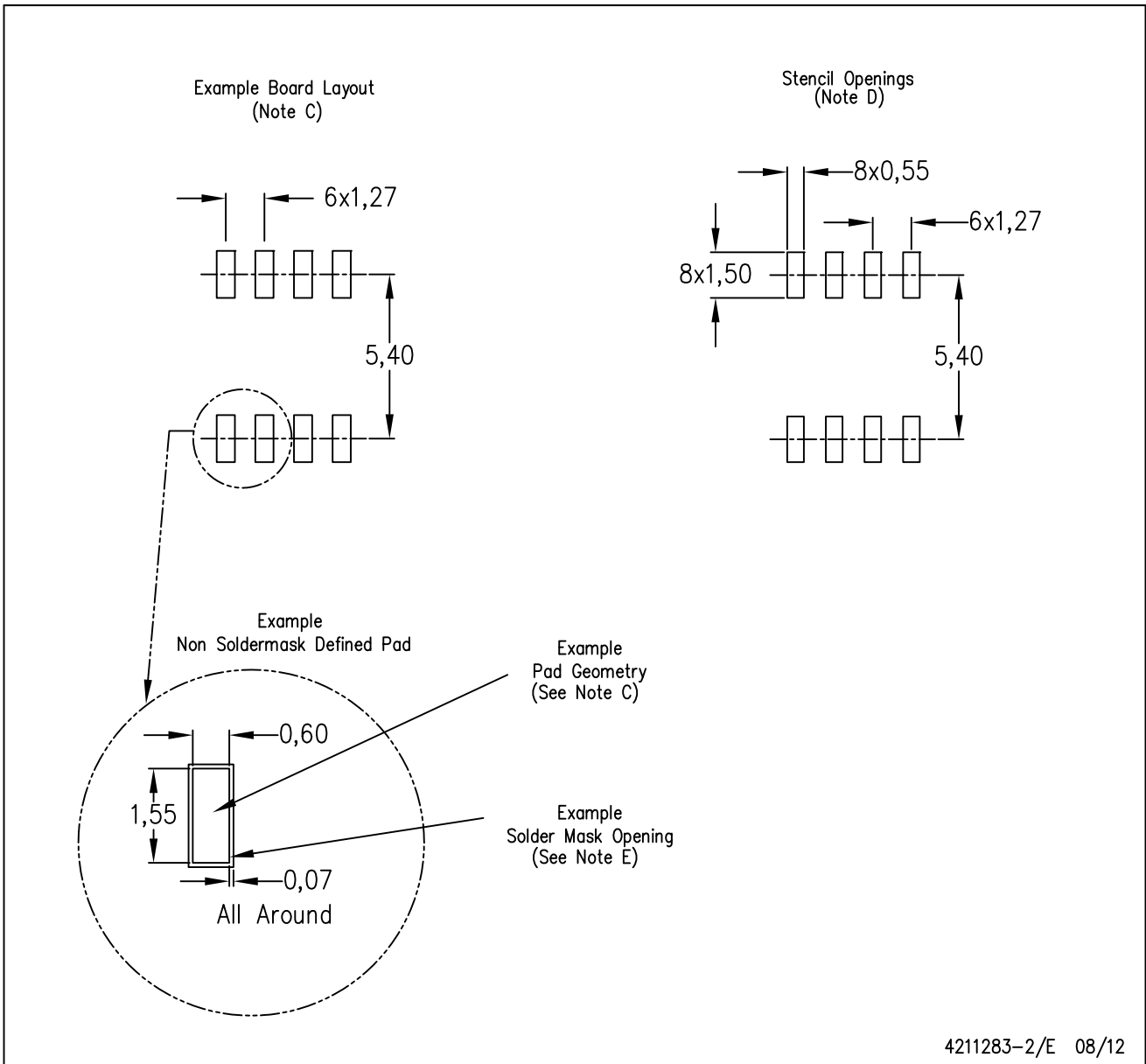

- NOTES:
- All linear dimensions are in millimeters.
 - This drawing is subject to change without notice.
 - Publication IPC-7351 is recommended for alternate designs.
 - Laser cutting apertures with trapezoidal walls and also rounding corners will offer better paste release. Customers should contact their board assembly site for stencil design recommendations. Refer to IPC-7525 for other stencil recommendations.
 - Customers should contact their board fabrication site for solder mask tolerances between and around signal pads.

IMPORTANT NOTICE

Texas Instruments Incorporated and its subsidiaries (TI) reserve the right to make corrections, enhancements, improvements and other changes to its semiconductor products and services per JESD46, latest issue, and to discontinue any product or service per JESD48, latest issue. Buyers should obtain the latest relevant information before placing orders and should verify that such information is current and complete. All semiconductor products (also referred to herein as "components") are sold subject to TI's terms and conditions of sale supplied at the time of order acknowledgment.

TI warrants performance of its components to the specifications applicable at the time of sale, in accordance with the warranty in TI's terms and conditions of sale of semiconductor products. Testing and other quality control techniques are used to the extent TI deems necessary to support this warranty. Except where mandated by applicable law, testing of all parameters of each component is not necessarily performed.

TI assumes no liability for applications assistance or the design of Buyers' products. Buyers are responsible for their products and applications using TI components. To minimize the risks associated with Buyers' products and applications, Buyers should provide adequate design and operating safeguards.

TI does not warrant or represent that any license, either express or implied, is granted under any patent right, copyright, mask work right, or other intellectual property right relating to any combination, machine, or process in which TI components or services are used. Information published by TI regarding third-party products or services does not constitute a license to use such products or services or a warranty or endorsement thereof. Use of such information may require a license from a third party under the patents or other intellectual property of the third party, or a license from TI under the patents or other intellectual property of TI.

Reproduction of significant portions of TI information in TI data books or data sheets is permissible only if reproduction is without alteration and is accompanied by all associated warranties, conditions, limitations, and notices. TI is not responsible or liable for such altered documentation. Information of third parties may be subject to additional restrictions.

Resale of TI components or services with statements different from or beyond the parameters stated by TI for that component or service voids all express and any implied warranties for the associated TI component or service and is an unfair and deceptive business practice. TI is not responsible or liable for any such statements.

Buyer acknowledges and agrees that it is solely responsible for compliance with all legal, regulatory and safety-related requirements concerning its products, and any use of TI components in its applications, notwithstanding any applications-related information or support that may be provided by TI. Buyer represents and agrees that it has all the necessary expertise to create and implement safeguards which anticipate dangerous consequences of failures, monitor failures and their consequences, lessen the likelihood of failures that might cause harm and take appropriate remedial actions. Buyer will fully indemnify TI and its representatives against any damages arising out of the use of any TI components in safety-critical applications.

In some cases, TI components may be promoted specifically to facilitate safety-related applications. With such components, TI's goal is to help enable customers to design and create their own end-product solutions that meet applicable functional safety standards and requirements. Nonetheless, such components are subject to these terms.

No TI components are authorized for use in FDA Class III (or similar life-critical medical equipment) unless authorized officers of the parties have executed a special agreement specifically governing such use.

Only those TI components which TI has specifically designated as military grade or "enhanced plastic" are designed and intended for use in military/aerospace applications or environments. Buyer acknowledges and agrees that any military or aerospace use of TI components which have **not** been so designated is solely at the Buyer's risk, and that Buyer is solely responsible for compliance with all legal and regulatory requirements in connection with such use.

TI has specifically designated certain components as meeting ISO/TS16949 requirements, mainly for automotive use. In any case of use of non-designated products, TI will not be responsible for any failure to meet ISO/TS16949.

Products

Audio	www.ti.com/audio
Amplifiers	amplifier.ti.com
Data Converters	dataconverter.ti.com
DLP® Products	www.dlp.com
DSP	dsp.ti.com
Clocks and Timers	www.ti.com/clocks
Interface	interface.ti.com
Logic	logic.ti.com
Power Mgmt	power.ti.com
Microcontrollers	microcontroller.ti.com
RFID	www.ti-rfid.com
OMAP Applications Processors	www.ti.com/omap
Wireless Connectivity	www.ti.com/wirelessconnectivity

Applications

Automotive and Transportation	www.ti.com/automotive
Communications and Telecom	www.ti.com/communications
Computers and Peripherals	www.ti.com/computers
Consumer Electronics	www.ti.com/consumer-apps
Energy and Lighting	www.ti.com/energy
Industrial	www.ti.com/industrial
Medical	www.ti.com/medical
Security	www.ti.com/security
Space, Avionics and Defense	www.ti.com/space-avionics-defense
Video and Imaging	www.ti.com/video

TI E2E Community

e2e.ti.com