

TPS63020-Q1 High Efficiency Single Inductor Buck-Boost Converter With 4-A Switches

1 Features

- Qualified for Automotive Applications
- AEC-Q100 Qualified with the Following Results:
 - Device Temperature Grade: -40°C to 125°C Operating Junction Temperature Range
 - Device HBM ESD Classification Level H1B
 - Device CDM ESD Classification Level C4B
- Input Voltage Range: 1.8 V to 5.5 V
- Up to 96% Efficiency
- 3 A Output Current at 3.3 V in Step Down Mode ($V_{\text{IN}} > 3.6\text{ V}$)
- More than 2 A Output Current at 3.3 V in Boost Mode ($V_{\text{IN}} > 2.5\text{ V}$)
- Automatic Transition Between Step Down and Boost Mode
- Dynamic Input Current Limit
- Device Quiescent Current less than 50 μA
- Adjustable Output Voltage Range from 1.2 V to 5.5 V
- Power Save Mode for Improved Efficiency at Low Output Power
- Forced Fixed Frequency Operation at 2.4 MHz and Synchronization Possible
- Smart Power Good Output
- Load Disconnect During Shutdown
- Overtemperature Protection
- Overvoltage Protection
- Available in a 3-mm x 4-mm, VSON-14 Package

4 Typical Application Schematic

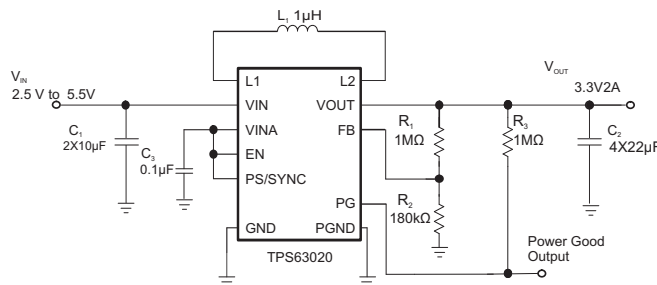

2 Applications

- Infotainment
- Telematics/eCall

3 Description

The TPS63020-Q1 device provides a power supply solution for products powered by either a two-cell or three-cell alkaline, NiCd or NiMH battery, or a one-cell Li-Ion or Li-Polymer battery. Output currents can go as high as 3 A while using a single-cell Li-Ion or Li-Polymer battery, and discharge it down to 2.5 V or lower. The buck-boost converter is based on a fixed frequency, pulse width modulation (PWM) controller using synchronous rectification to obtain maximum efficiency. At low load currents, the converter enters power save mode to maintain high efficiency over a wide load current range. The power save mode can be disabled, forcing the converter to operate at a fixed switching frequency. The maximum average current in the switches is limited to a typical value of 4 A. The output voltage is programmable using an external resistor divider. The converter can be disabled to minimize battery drain. During shutdown, the load is disconnected from the battery. The device is packaged in a 3 mm x 4 mm 14-pin VSON PowerPAD™ package (DSJ).

Device Information⁽¹⁾

PART NUMBER	PACKAGE	BODY SIZE (NOM)
TPS63020-Q1	VSON (14)	3.00 mm x 4.00 mm

(1) For all available packages, see the orderable addendum at the end of the data sheet.

Efficiency vs Output Current

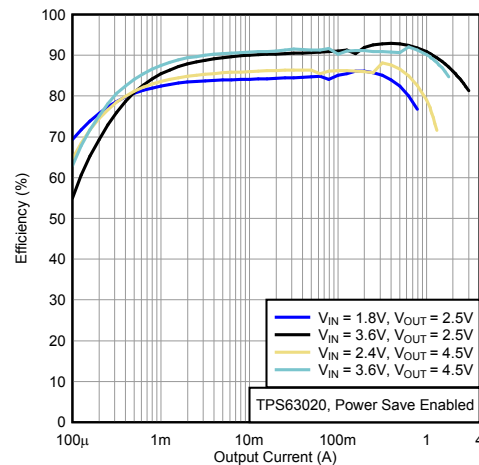

Table of Contents

1 Features	1	9.4 Device Functional Modes.....	9
2 Applications	1	10 Application and Implementation	12
3 Description	1	10.1 Application Information.....	12
4 Typical Application Schematic	1	10.2 Typical Application	12
5 Revision History	2	10.3 System Examples	17
6 Device Comparison Table	3	11 Power Supply Recommendations	18
7 Pin Configuration and Functions	3	12 Layout	18
8 Specifications	4	12.1 Layout Guidelines	18
8.1 Absolute Maximum Ratings	4	12.2 Layout Example	18
8.2 ESD Ratings	4	12.3 Thermal Considerations.....	19
8.3 Recommended Operating Conditions.....	4	13 Device and Documentation Support	20
8.4 Thermal Information	4	13.1 Device Support.....	20
8.5 Electrical Characteristics.....	5	13.2 Documentation Support	20
8.6 Typical Characteristics.....	6	13.3 Community Resources.....	20
9 Detailed Description	7	13.4 Trademarks	20
9.1 Overview	7	13.5 Electrostatic Discharge Caution.....	20
9.2 Functional Block Diagram	7	13.6 Glossary	20
9.3 Feature Description.....	7	14 Mechanical, Packaging, and Orderable Information	20

5 Revision History

DATE	REVISION	NOTES
October 2015	*	Initial release.

6 Device Comparison Table

PART NUMBER	V _{OUT}
TPS63020-Q1	Adjustable

7 Pin Configuration and Functions

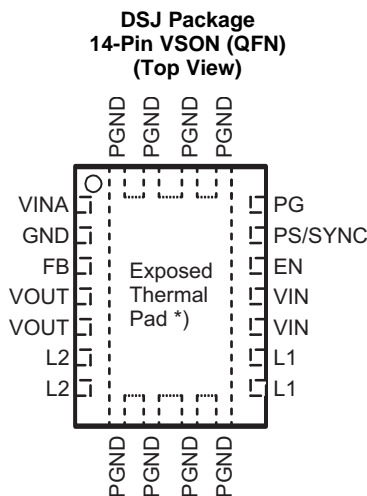

NOTE: *) The exposed thermal pad is connected to PGND.

See *TPS63020-Q1 Pin FMEA* Application Report [SLVA736](#)

Pin Functions

PIN		I/O	DESCRIPTION
NAME	NO.		
EN	12	I	Enable input (1 enabled, 0 disabled), must not be left open
FB	3	I	Voltage feedback of adjustable versions.
GND	2		Control/logic ground
L1	8, 9	I	Connection for inductor
L2	6, 7	I	Connection for inductor
PG	14	O	Output power good (1 good, 0 failure; open drain)
PGND			Power ground
PS/SYNC	13	I	Enable/disable power save mode (1 disabled, 0 enabled, clock signal for synchronization), must not be left open
VIN	10, 11	I	Supply voltage for power stage
VINA	1	I	Supply voltage for control stage
VOUT	4, 5	O	Buck-boost converter output
Exposed Thermal Pad			The exposed thermal pad is connected to PGND.

8 Specifications

8.1 Absolute Maximum Ratings

Over operating junction temperature range (unless otherwise noted)⁽¹⁾

		MIN	MAX	UNIT
Voltage ⁽²⁾	VIN, VINA, L1, L2, VOUT, PS/SYNC, EN, FB, PG	-0.3	7	V
Operating junction temperature, T _J		-40	150	°C
Storage temperature, T _{stg}		-65	150	°C

- (1) Stresses beyond those listed under *Absolute Maximum Ratings* may cause permanent damage to the device. These are stress ratings only, which do not imply functional operation of the device at these or any other conditions beyond those indicated under *Recommended Operating Conditions*. Exposure to absolute-maximum-rated conditions for extended periods may affect device reliability.
- (2) All voltages are with respect to network ground terminal.

8.2 ESD Ratings

			Value	UNIT
V _(ESD)	Electrostatic discharge ⁽¹⁾	Human body model (HBM), per AEC Q100-002 ⁽²⁾	±1000	V
		Charged device model (CDM), per AEC Q100-011	±500	

- (1) Electrostatic discharge (ESD) measures device sensitivity and immunity to damage caused by assembly line electrostatic discharges
- (2) JAEC Q100-002 indicates HBM stressing is done in accordance with the ANSI/ESDA/JEDEC JS-001 specification

8.3 Recommended Operating Conditions

Over operating junction temperature range (unless otherwise noted)

		MIN	NOM	MAX	UNIT
Supply voltage at VIN, VINA		1.8		5.5	V
Operating junction temperature range, T _J		-40		125	°C

8.4 Thermal Information

THERMAL METRIC ⁽¹⁾		TPS63020-Q1	UNIT
		DSJ (VSON)	
		14 PINS	
R _{θJA}	Junction-to-ambient thermal resistance	41.8	°C/W
R _{θJC(top)}	Junction-to-case (top) thermal resistance	47	°C/W
R _{θJB}	Junction-to-board thermal resistance	17	°C/W
Ψ _{JT}	Junction-to-top characterization parameter	0.9	°C/W
Ψ _{JB}	Junction-to-board characterization parameter	16.8	°C/W
R _{θJC(bot)}	Junction-to-case (bottom) thermal resistance	3.6	°C/W

- (1) For more information about traditional and new thermal metrics, see the *Semiconductor and IC Package Thermal Metrics* application report, [SPRA953](#).

8.5 Electrical Characteristics

 $V_{IN} = 1.8\text{ V to }5.5\text{ V}$, $T_J = -40^\circ\text{C to }125^\circ\text{C}$, typical values are at $T_A = 25^\circ\text{C}$ (unless otherwise noted)

PARAMETER		TEST CONDITIONS	MIN	TYP	MAX	UNIT		
DC/DC STAGE								
V_{IN}	Input voltage range		1.8		5.5	V		
	Minimum input voltage for startup		$0^\circ\text{C} \leq T_A \leq 85^\circ\text{C}$		1.5	1.8	1.9	V
	Minimum input voltage for startup			1.5	1.8	2.0	V	
V_{OUT}	TPS63020 output voltage range		1.2		5.5	V		
	Duty cycle in step down conversion		20%					
V_{FB}	TPS63020 feedback voltage		PS/SYNC = V_{IN}		495	500	505	mV
V_{FB}	TPS63020 feedback voltage		PS/SYNC = GND referenced to 500 mV		0.6%		5%	
	Maximum line regulation				0.5%			
	Maximum load regulation				0.5%			
f	Oscillator frequency		2200	2400	2600	kHz		
	Frequency range for synchronization		$2.0\text{ V} \leq V_{IN} \leq 5.5\text{ V}$		2200	2400	2600	kHz
I_{SW}	Average switch current limit		$V_{IN} = V_{INA} = 3.6\text{ V}$, $T_J = 25^\circ\text{C}$		3500	4000	4500	mA
	High side switch on resistance		$V_{IN} = V_{INA} = 3.6\text{ V}$		50		m Ω	
	Low side switch on resistance		$V_{IN} = V_{INA} = 3.6\text{ V}$		50		m Ω	
I_q	Quiescent current	VIN and VINA	$I_O = 0\text{ mA}$, $V_{EN} = V_{IN} = V_{INA} = 3.6\text{ V}$, $V_{OUT} = 3.3\text{ V}$, $-40^\circ\text{C} \leq T_J \leq 85^\circ\text{C}$		25	50	μA	
		VOUT			5	10	μA	
I_S	Shutdown current		$V_{EN} = 0\text{ V}$, $V_{IN} = V_{INA} = 3.6\text{ V}$, $-40^\circ\text{C} \leq T_J \leq 85^\circ\text{C}$		0.1	1	μA	
CONTROL STAGE								
UVLO	Under voltage lockout threshold		V_{INA} voltage decreasing		1.4	1.5	1.6	V
	Under voltage lockout hysteresis				200		mV	
V_{IL}	EN, PS/SYNC input low voltage				0.4		V	
V_{IH}	EN, PS/SYNC input high voltage				1.2		V	
	EN, PS/SYNC input current		Clamped to GND or VINA		0.01	0.2	μA	
	PG output low voltage		$V_{OUT} = 3.3\text{ V}$, $I_{PGL} = 10\text{ }\mu\text{A}$		0.04	0.4	V	
	PG output leakage current				0.01	0.1	μA	
	Output overvoltage protection				5.5	7	V	
	Overtemperature protection				140		$^\circ\text{C}$	
	Overtemperature hysteresis				20		$^\circ\text{C}$	

8.6 Typical Characteristics

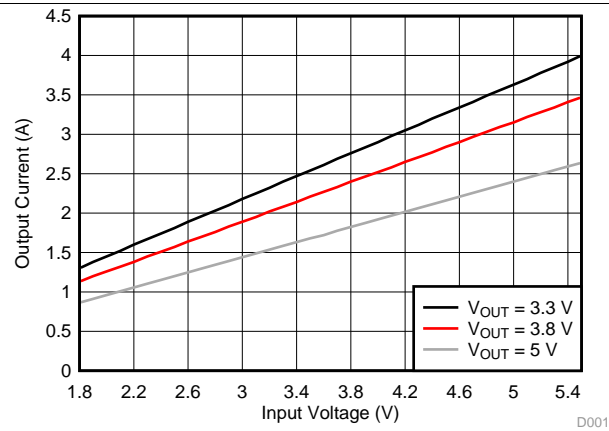

Figure 1. Output Current vs Input Voltage at $T_J = 125^\circ\text{C}$

9 Detailed Description

9.1 Overview

The controller circuit of the device is based on an average current mode topology. The controller also uses input and output voltage feedforward. Changes of input and output voltage are monitored and immediately can change the duty cycle in the modulator to achieve a fast response to those errors. The voltage error amplifier gets its feedback input from the FB pin. At adjustable output voltages, a resistive voltage divider must be connected to that pin. At fixed output voltages, FB must be connected to the output voltage to directly sense the voltage. Fixed output voltage versions use a trimmed internal resistive divider. The feedback voltage will be compared with the internal reference voltage to generate a stable and accurate output voltage.

The device uses 4 internal N-channel MOSFETs to maintain synchronous power conversion at all possible operating conditions. This enables the device to keep high efficiency over a wide input voltage and output power range. To avoid ground shift problems due to the high currents in the switches, two separate ground pins GND and PGND are used. The reference for all control functions is the GND pin. The power switches are connected to PGND. Both grounds must be connected on the PCB at only one point, ideally, close to the GND pin. Due to the 4-switch topology, the load is always disconnected from the input during shutdown of the converter. To protect the device from overheating an internal temperature sensor is implemented.

9.2 Functional Block Diagram

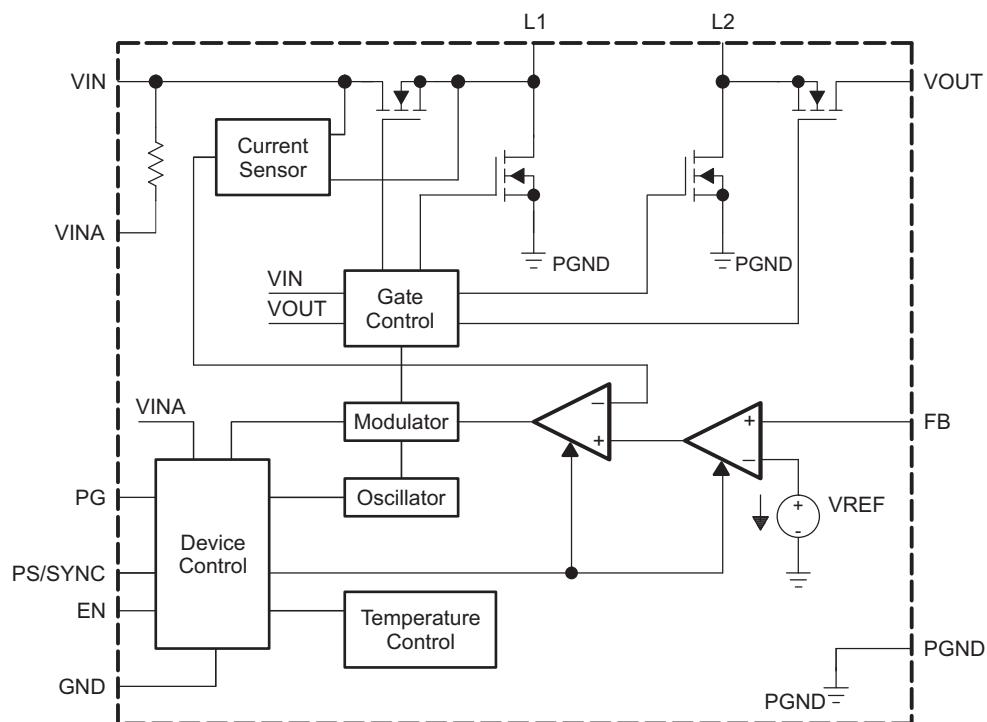

9.3 Feature Description

9.3.1 Dynamic Voltage Positioning

As detailed in [Figure 3](#), the output voltage is typically 3% above the nominal output voltage at light load currents, as the device is in power save mode. This gives additional headroom for the voltage drop during a load transient from light load to full load. This allows the converter to operate with a small output capacitor and still have a low absolute voltage drop during heavy load transient changes. See [Figure 3](#) for detailed operation of the power save mode.

Feature Description (continued)

9.3.2 Dynamic Current Limit

To protect the device and the application, the average inductor current is limited internally on the IC. At nominal operating conditions, this current limit is constant. The current limit value can be found in the electrical characteristics table. If the supply voltage at VIN drops below 2.3 V, the current limit is reduced. This can happen when the input power source becomes weak. Increasing output impedance, when the batteries are almost discharged, or an additional heavy pulse load is connected to the battery can cause the VIN voltage to drop. The dynamic current limit has its lowest value when reaching the minimum recommended supply voltage at VIN. At this voltage, the device is forced into burst mode operation trying to stay active as long as possible even with a weak input power source.

If the die temperature increases above the recommended maximum temperature, the dynamic current limit becomes active. Similar to the behavior when the input voltage at VIN drops, the current limit is reduced with temperature increasing.

9.3.2.1 Device Enable

The device is put into operation when EN is set high. It is put into a shutdown mode when EN is set to GND. In shutdown mode, the regulator stops switching, all internal control circuitry is switched off, and the load is disconnected from the input. This means that the output voltage can drop below the input voltage during shutdown. During start-up of the converter, the duty cycle and the peak current are limited in order to avoid high peak currents flowing from the input.

9.3.2.2 Power Good

The device has a built in power good function to indicate whether the output voltage is regulated properly. As soon as the average inductor current gets limited to a value below the current the voltage regulator demands for maintaining the output voltage the power good output gets low impedance. The output is open drain, so its logic function can be adjusted to any voltage level the connected logic is using, by connecting a pull up resistor to the supply voltage of the logic. By monitoring the status of the current control loop, the power good output provides the earliest indication possible for an output voltage break down and leaves the connected application a maximum time to safely react.

9.3.2.3 Overvoltage Protection

If, for any reason, the output voltage is not fed back properly to the input of the voltage amplifier, control of the output voltage will not work anymore. Therefore overvoltage protection is implemented to avoid the output voltage exceeding critical values for the device and possibly for the system it is supplying. The implemented overvoltage protection circuit monitors the output voltage internally as well. In case it reaches the overvoltage threshold the voltage amplifier regulates the output voltage to this value.

9.3.2.4 Undervoltage Lockout

An undervoltage lockout function prevents device start-up if the supply voltage at VINA is lower than approximately its threshold (see electrical characteristics table). When in operation, the device automatically enters the shutdown mode if the voltage at VINA drops below the undervoltage lockout threshold. The device automatically restarts if the input voltage recovers to the minimum operating input voltage.

9.3.2.5 Overtemperature Protection

The device has a built-in temperature sensor which monitors the internal IC temperature. If the temperature exceeds the programmed threshold (see electrical characteristics table) the device stops operating. As soon as the IC temperature has decreased below the programmed threshold, it starts operating again. There is a built-in hysteresis to avoid unstable operation at IC temperatures at the overtemperature threshold.

9.4 Device Functional Modes

9.4.1 Softstart and Short Circuit Protection

After being enabled, the device starts operating. The average current limit ramps up from an initial 400 mA following the output voltage increasing. At an output voltage of about 1.2 V, the current limit is at its nominal value. If the output voltage does not increase, the current limit will not increase. There is no timer implemented. Thus, the output voltage overshoot at startup, as well as the inrush current, is kept at a minimum. The device ramps up the output voltage in a controlled manner even if a large capacitor is connected at the output. When the output voltage does not increase above 1.2 V, the device assumes a short circuit at the output, and keeps the current limit low to protect itself and the application. At a short on the output during operation, the current limit also is decreased accordingly.

9.4.2 Buck-Boost Operation

To regulate the output voltage at all possible input voltage conditions, the device automatically switches from step down operation to boost operation and back as required by the configuration. It always uses one active switch, one rectifying switch, one switch permanently on, and one switch permanently off. Therefore, it operates as a step down converter (buck) when the input voltage is higher than the output voltage, and as a boost converter when the input voltage is lower than the output voltage. There is no mode of operation in which all 4 switches are permanently switching. Controlling the switches this way allows the converter to maintain high efficiency at the most important point of operation, when input voltage is close to the output voltage. The RMS current through the switches and the inductor is kept at a minimum, to minimize switching and conduction losses. For the remaining 2 switches, one is kept permanently on and the other is kept permanently off, thus causing no switching losses.

9.4.3 Control Loop

The controller circuit of the device is based on an average current mode topology. The average inductor current is regulated by a fast current regulator loop which is controlled by a voltage control loop. [Figure 2](#) shows the control loop.

The non inverting input of the transconductance amplifier, gm_v, is assumed to be constant. The output of gm_v defines the average inductor current. The inductor current is reconstructed by measuring the current through the high side buck MOSFET. This current corresponds exactly to the inductor current in boost mode. In buck mode the current is measured during the on time of the same MOSFET. During the off time, the current is reconstructed internally starting from the peak value at the end of the on time cycle. The average current and the feedback from the error amplifier gm_v forms the correction signal g_mc. This correction signal is compared to the buck and the boost sawtooth ramp giving the PWM signal. Depending on which of the two ramps the g_mc output crosses either the Buck or the Boost stage is initiated. When the input voltage is close to the output voltage, one buck cycle is always followed by a boost cycle. In this condition, no more than three cycles in a row of the same mode are allowed. This control method in the buck-boost region ensures a robust control and the highest efficiency.

The Buck-Boost Overlap Control™ makes sure that the classical buck-boost function, which would cause two switches to be on every half a cycle, is avoided. Thanks to this block whenever all switches becomes active during one clock cycle, the two ramps are shifted away from each other, on the other hand when there is no switching activities because there is a gap between the ramps, the ramps are moved closer together. As a result the number of classical buck-boost cycles or no switching is reduced to a minimum and high efficiency values has been achieved.

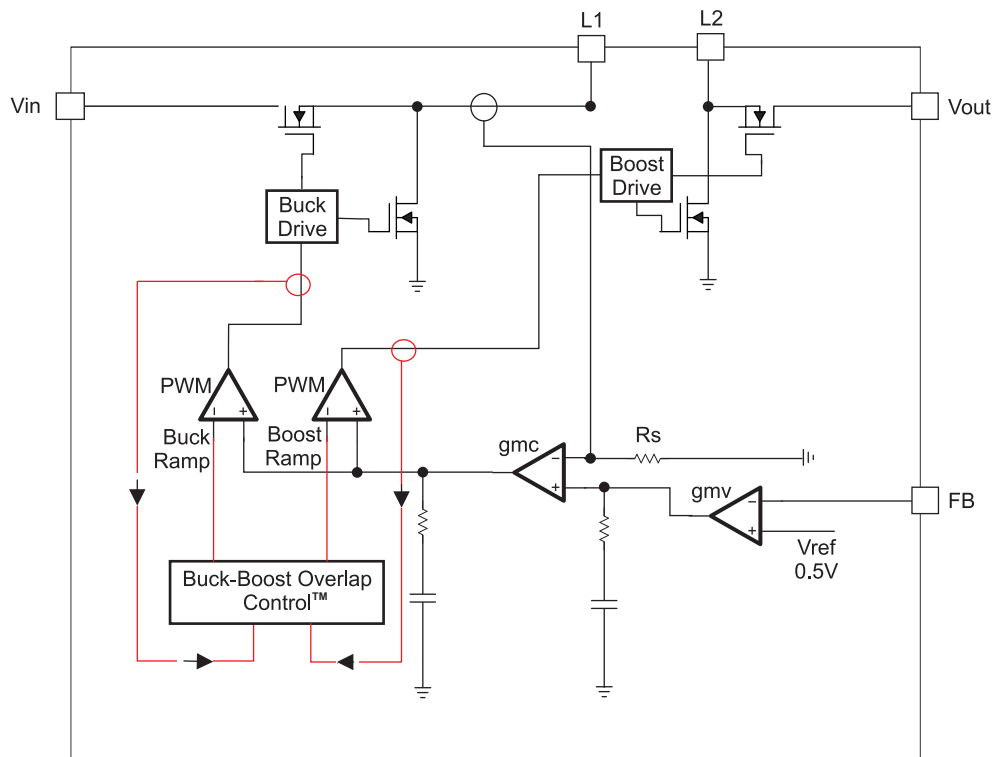
Device Functional Modes (continued)

Figure 2. Average Current Mode Control
9.4.4 Power Save Mode and Synchronization

The PS/SYNC pin can be used to select different operation modes. Power save mode is used to improve efficiency at light load. To enable power-save, PS/SYNC must be set low. If PS/SYNC is set low then power save mode is entered when the average inductor current gets lower than about 100 mA. At this point the converter operates with reduced switching frequency and with a minimum quiescent current to maintain high efficiency.

During the power save mode, the output voltage is monitored with a comparator by the threshold comp low and comp high. When the device enters power save mode, the converter stops operating and the output voltage drops. The slope of the output voltage depends on the load and the value of output capacitance. As the output voltage falls below the comp low threshold set to 2.5% typical above V_{OUT} , the device ramps up the output voltage again, by starting operation using a programmed average inductor current higher than required by the current load condition. Operation can last one or several pulses. The converter continues these pulses until the comp high threshold, set to typically 3.5% above V_{OUT} nominal, is reached and the average inductance current gets lower than about 100 mA. When the load increases above the minimum forced inductor current of about 100 mA, the device will automatically switch to PWM mode.

The power save mode can be disabled by programming high at the PS/SYNC. Connecting a clock signal at PS/SYNC forces the device to synchronize to the connected clock frequency.

Synchronization is done by a PLL, so synchronizing to lower and higher frequencies compared to the internal clock works without any issues. The PLL can also tolerate missing clock pulses without the converter malfunctioning. The PS/SYNC input supports standard logic thresholds.

Device Functional Modes (continued)

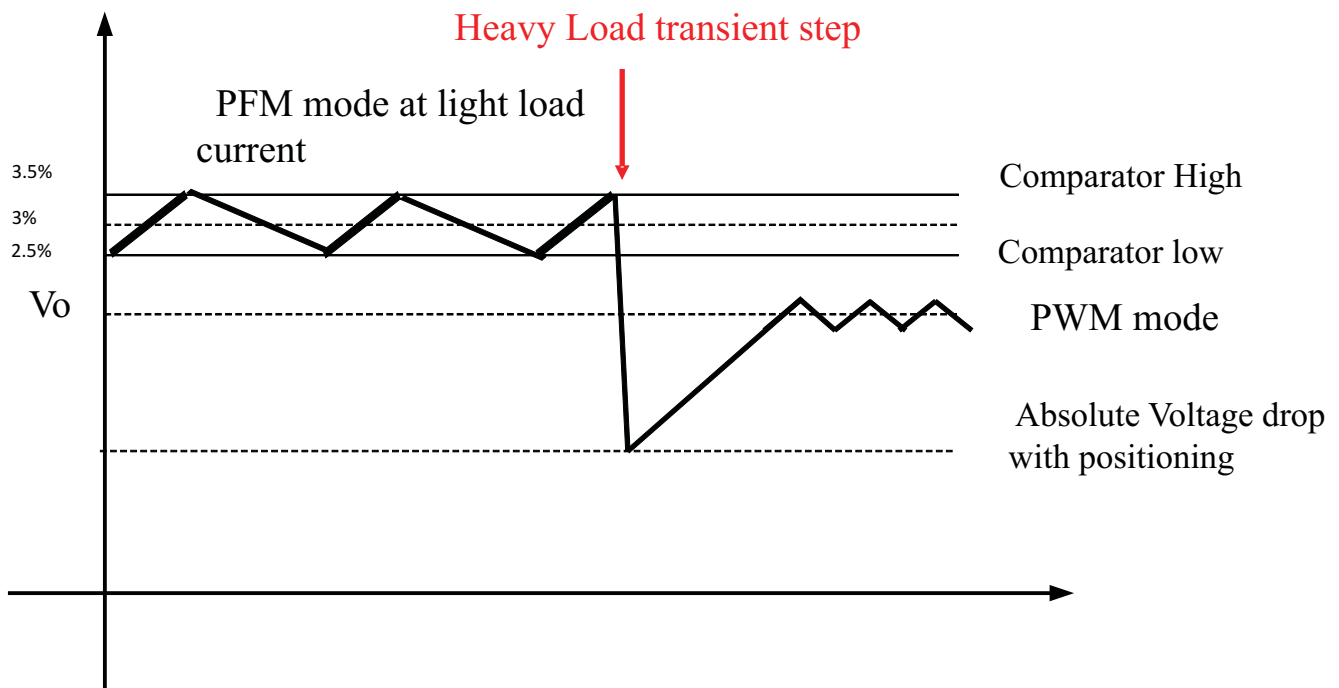

Figure 3. Power Save Mode Thresholds and Dynamic Voltage Positioning

10 Application and Implementation

NOTE

Information in the following applications sections is not part of the TI component specification, and TI does not warrant its accuracy or completeness. TI's customers are responsible for determining suitability of components for their purposes. Customers should validate and test their design implementation to confirm system functionality.

10.1 Application Information

The TPS63020-Q1 is a high efficiency, low quiescent current buck-boost converter suitable for applications where the input voltage is higher or lower than the output voltage. Continuous output current can go as high as 2 A in boost mode and as high as 4 A in buck mode. The maximum average current in the switches is limited to a typical value of 4 A.

10.2 Typical Application

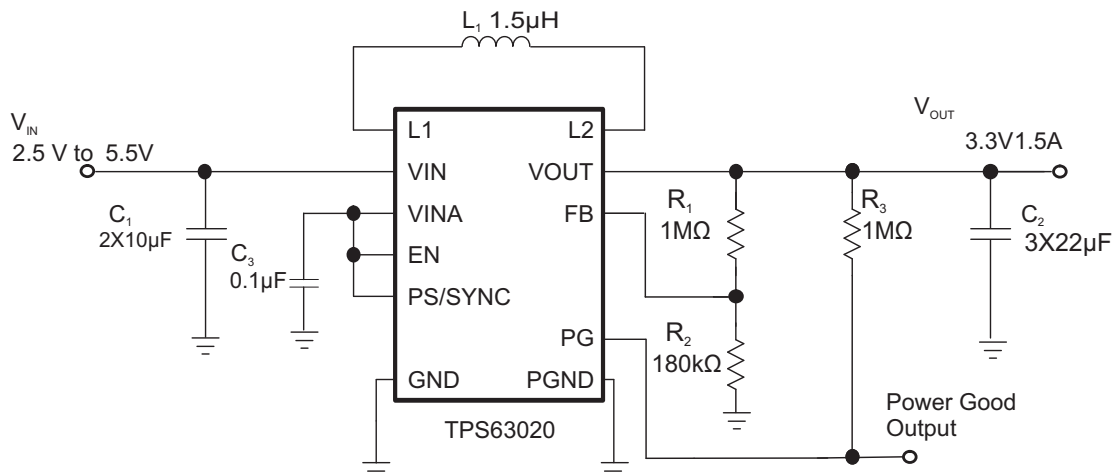

Figure 4. Application Circuit

10.2.1 Design Requirements

The design guidelines provide a component selection to operate the device within the operating conditions specified on the Application Circuit schematic.

Table 1 shows the list of components for the Application Characteristic Curves.

Table 1. List of Components

REFERENCE	DESCRIPTION	MANUFACTURER
	TPS63020	Texas Instruments
L1	1.5 µH, 4 mm x 4 mm x 2 mm	XFL4020-152ML, Coilcraft
C1	2 × 10 µF 6.3V, 0603, X5R ceramic	GRM188R60J106ME84D, Murata
C2	3 × 22 µF 6.3V, 0603, X5R ceramic	GRM188R60J226MEAOL Murata
C3	0.1 µF, X5R or X7R ceramic	
R1	Depending on the output voltage at TPS63020	
R2	Depending on the output voltage at TPS63020	
R3	1 MΩ	

10.2.2 Detailed Design Procedure

The TPS63020-Q1 series of buck-boost converter has internal loop compensation. Therefore, the external L-C filter has to be selected to work with the internal compensation. As a general rule of thumb, the product $L \times C$ should not move over a wide range when selecting a different output filter. However, when selecting the output filter a low limit for the inductor value exists to avoid subharmonic oscillation which could be caused by a far too fast ramp up of the amplified inductor current. For the TPS63020-Q1 series the minimum inductor value should be kept at 1 μH .

In particular either 1 μH or 1.5 μH is recommended working at output current between 1.5 A and 2 A. If operating with lower load current is also possible to use 2.2 μH .

Selecting a larger output capacitor value is less critical because the corner frequency moves to lower frequencies.

10.2.2.1 Inductor Selection

For high efficiencies, the inductor should have a low dc resistance to minimize conduction losses. Especially at high-switching frequencies, the core material has a high impact on efficiency. When using small chip inductors, the efficiency is reduced mainly due to higher inductor core losses. This needs to be considered when selecting the appropriate inductor. The inductor value determines the inductor ripple current. The larger the inductor value, the smaller the inductor ripple current and the lower the conduction losses of the converter. Conversely, larger inductor values cause a slower load transient response. To avoid saturation of the inductor, the peak current for the inductor in steady state operation is calculated using Equation 6. Only the equation which defines the switch current in boost mode is shown, because this provides the highest value of current and represents the critical current value for selecting the right inductor.

$$\text{Duty Cycle Boost} \quad D = \frac{V_{\text{OUT}} - V_{\text{IN}}}{V_{\text{OUT}}} \quad (1)$$

$$I_{\text{PEAK}} = \frac{I_{\text{out}}}{\eta \times (1 - D)} + \frac{V_{\text{in}} \times D}{2 \times f \times L}$$

where

- D = Duty Cycle in Boost mode
- f = Converter switching frequency (typical 2.5MHz)
- L = Inductor value
- η = Estimated converter efficiency (use the number from the efficiency curves or 0.90 as an assumption)
- **Note:** The calculation must be done for the minimum input voltage possible in boost mode

Calculating the maximum inductor current using the actual operating conditions gives the minimum saturation current of the inductor needed. It's recommended to choose an inductor with a saturation current 20% higher than the value calculated using Equation 2. Possible inductors are listed in Table 2.

Table 2. Inductor Selection⁽¹⁾

VENDOR	INDUCTOR SERIES
Coilcraft	XFL4020
Toko	FDV0530S

(1) See [Third-party Products Disclaimer](#)

10.2.2.2 Capacitor Selection

10.2.2.2.1 Input Capacitor

At least a 10 μF input capacitor is recommended to improve transient behavior of the regulator and EMI behavior of the total power supply circuit. A ceramic capacitor placed as close as possible to the VIN and PGND pins of the IC is recommended.

10.2.2.2.2 Output Capacitor

For the output capacitor, use of a small ceramic capacitors placed as close as possible to the VOUT and PGND pins of the IC is recommended. If, for any reason, the application requires the use of large capacitors which can not be placed close to the IC, use a smaller ceramic capacitor in parallel to the large capacitor. The small capacitor should be placed as close as possible to the VOUT and PGND pins of the IC. The recommended typical output capacitor value is 30 μF with a variance that depends on the specific application requirements.

There is also no upper limit for the output capacitance value. Larger capacitors will cause lower output voltage ripple as well as lower output voltage drop during load transients.

When choosing input and output capacitors, it needs to be kept in mind, that the value of capacitance experiences significant losses from their rated value depending on the operating temperature and the operating DC voltage. It is not uncommon for a small surface mount ceramic capacitor to lose 50% and more of its rated capacitance. For this reason it could be important to use a larger value of capacitance or a capacitor with higher voltage rating in order to ensure the required capacitance at the full operating voltage.

10.2.2.2.3 Bypass Capacitor

To make sure that the internal control circuits are supplied with a stable low noise supply voltage, a capacitor can be connected between VINA and GND. Using a ceramic capacitor with a value of 0.1 μF is recommended. The value of this capacitor should not be higher than 0.22 μF .

10.2.2.3 Setting the Output Voltage

The feedback resistor divider must be connected between VOUT, FB and GND. When the output voltage is regulated, the typical value of the voltage at the FB pin is 500 mV. The maximum recommended value for the output voltage is 8 V. The current through the resistive divider should be about 100 times greater than the current into the FB pin. The typical current into the FB pin is 0.01 μA , and the voltage across the resistor between FB and GND, R_2 , is typically 500 mV. Based on these two values, the recommended value for R_2 should be lower than 500 k Ω , in order to set the divider current at 1 μA or higher. It is recommended to keep the value for this resistor in the range of 200 k Ω . From that, the value of the resistor connected between VOUT and FB, R_1 , depending on the needed output voltage (V_{OUT}), can be calculated using [Equation 3](#):

$$R_1 = R_2 \times \left(\frac{V_{\text{OUT}}}{V_{\text{FB}}} - 1 \right) \quad (3)$$

10.2.3 Application Curves

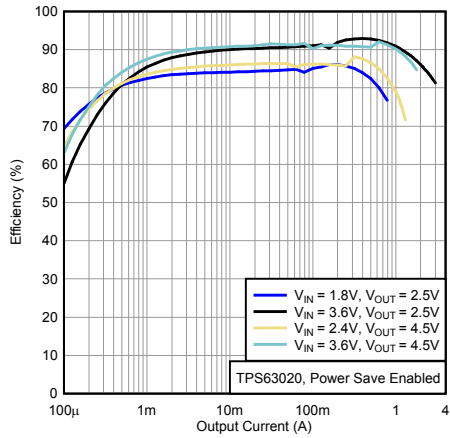

PS/SYNC = Low $V_{OUT} = 2.5\text{ V}, 4.5\text{ V}$

Figure 5. Efficiency vs Output Current, Power Save Enabled

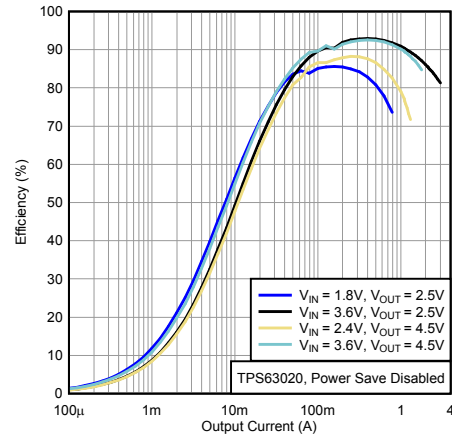

PS/SYNC = High $V_{OUT} = 2.5\text{ V}, 4.5\text{ V}$

Figure 6. Efficiency vs Output Current, Power Save Disabled

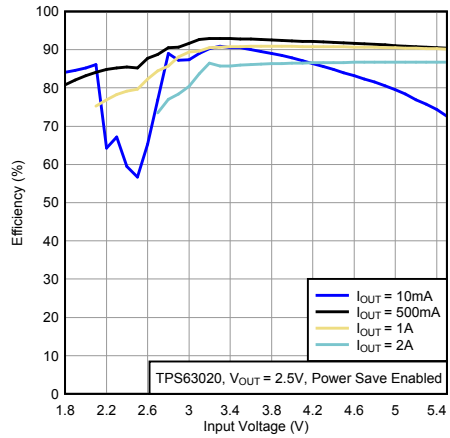

PS/SYNC = Low $V_{OUT} = 2.5\text{ V}$

Figure 7. Efficiency vs Input Voltage, Power Save Enabled

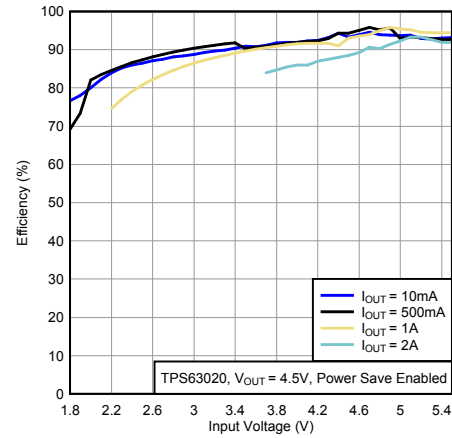

PS/SYNC = Low $V_{OUT} = 4.5\text{ V}$

Figure 8. Efficiency vs Input Voltage, Power Save Enabled

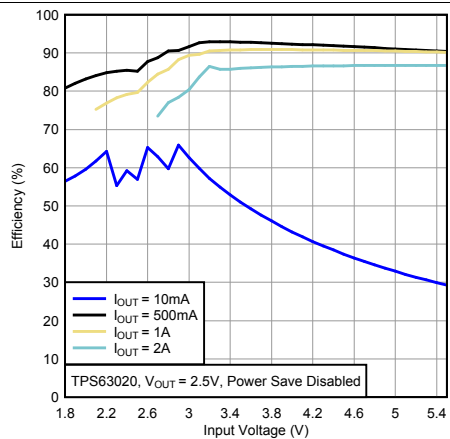

PS/SYNC = High $V_{OUT} = 2.5\text{ V}$

Figure 9. Efficiency vs Input Voltage, Power Save Disabled

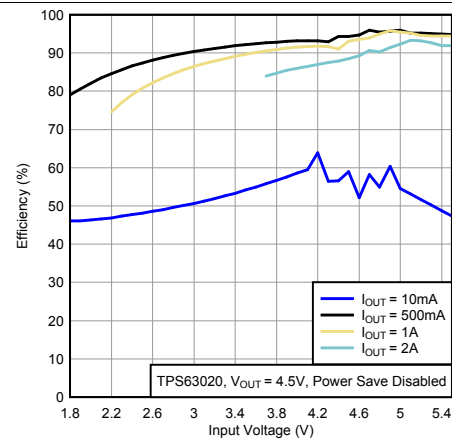

PS/SYNC = High $V_{OUT} = 4.5\text{ V}$

Figure 10. Efficiency vs Input Voltage, Power Save Disabled

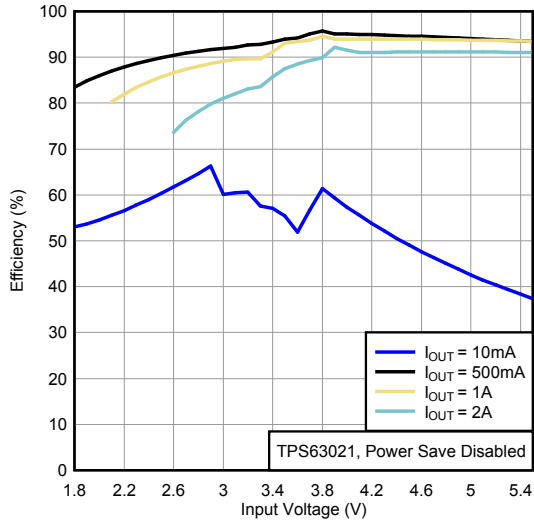

PS/SYNC = High $V_{OUT} = 2.5\text{ V}, 4.5\text{ V}$

Figure 11. Efficiency vs Input Voltage, Power Save Disabled

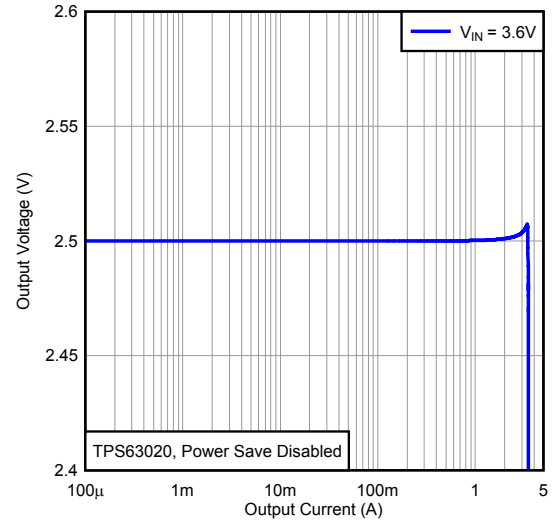

PS/SYNC = High $V_{OUT} = 2.5\text{ V}$

Figure 12. Load Transient Response

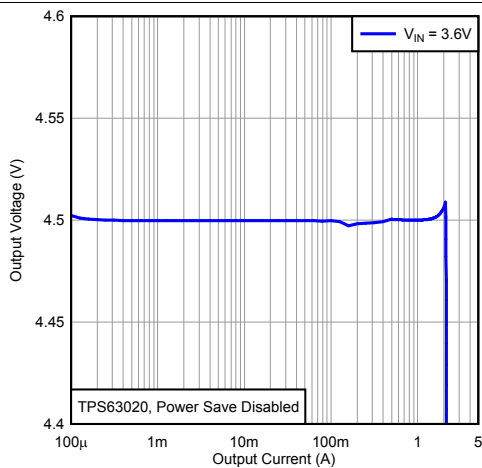

PS/SYNC = High $V_{OUT} = 4.5\text{ V}$

Figure 13. Load Transient Response

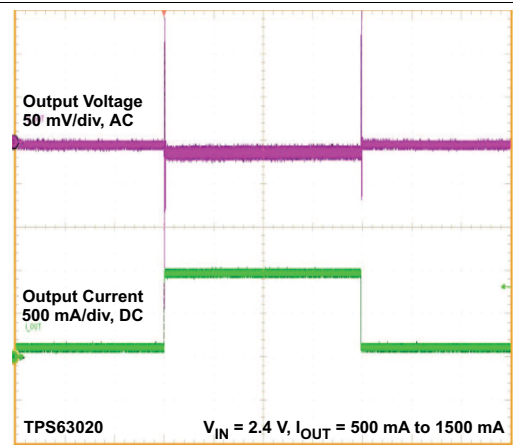

PS/SYNC = High $V_{OUT} = 3.3\text{ V}$

Figure 14. Load Transient Response

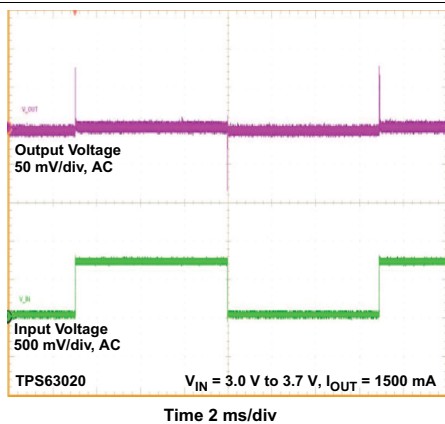

PS/SYNC = High $V_{OUT} = 3.3\text{ V}$

Figure 15. Load Transient Response

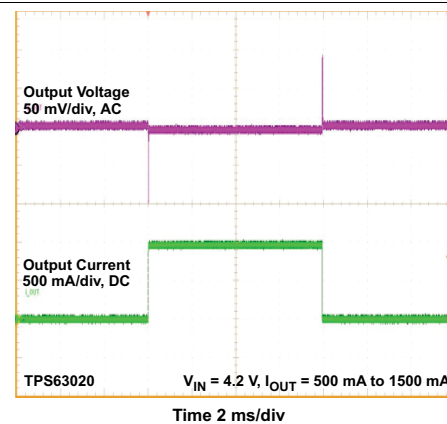

PS/SYNC = High $V_{OUT} = 3.3\text{ V}$

Figure 16. Line Transient Response

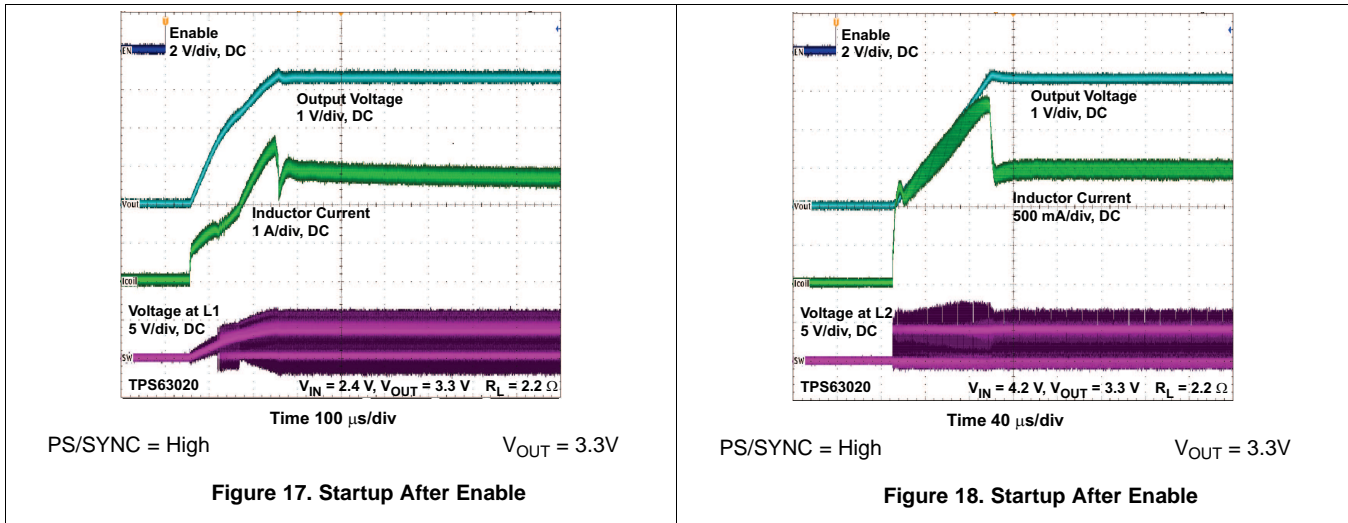

10.3 System Examples

10.3.1 2-A Load Current

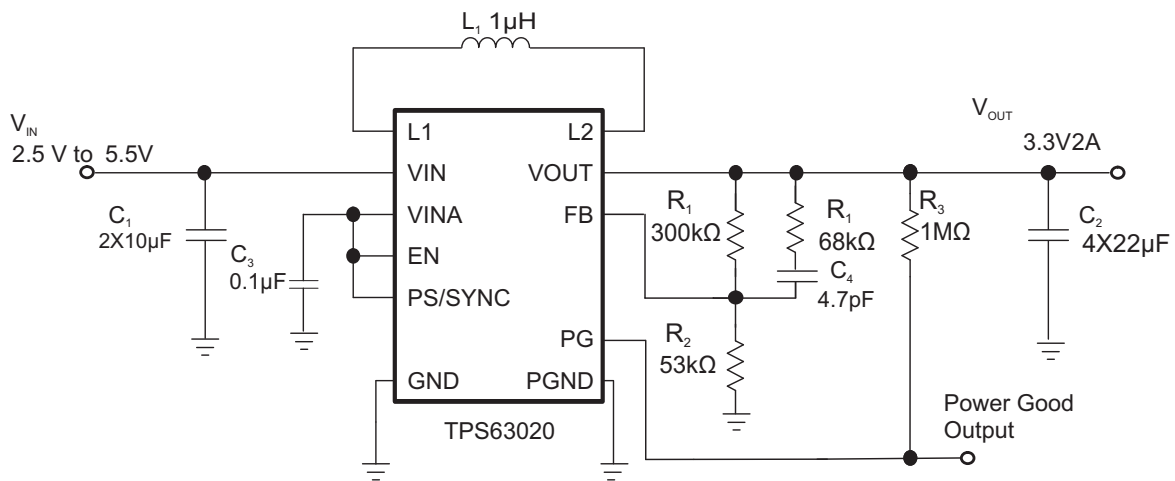

Figure 19. Application Circuit for 2A Load Current

Capacitor C4 and resistor R1 are added for improved load transient performance..

11 Power Supply Recommendations

The TPS63020-Q1 device has no special requirements for its input power supply.

The output current of the power supply must be rated according to the supply voltage, output voltage and output current of the TPS63020-Q1.

12 Layout

12.1 Layout Guidelines

For all switching power supplies, the layout is an important step in the design, especially at high peak currents and high switching frequencies. If the layout is not carefully done, the regulator could show stability problems as well as EMI problems. Therefore, use wide and short traces for the main current path and for the power ground tracks. The input capacitor, output capacitor, and the inductor should be placed as close as possible to the IC. Use a common ground node for power ground and a different one for control ground to minimize the effects of ground noise. Connect these ground nodes at any place close to one of the ground pins of the IC.

The feedback divider should be placed as close as possible to the control ground pin of the IC. To lay out the control ground, short traces are recommended as well, separation from the power ground traces. This avoids ground shift problems, which can occur due to superimposition of power ground current and control ground current.

12.2 Layout Example

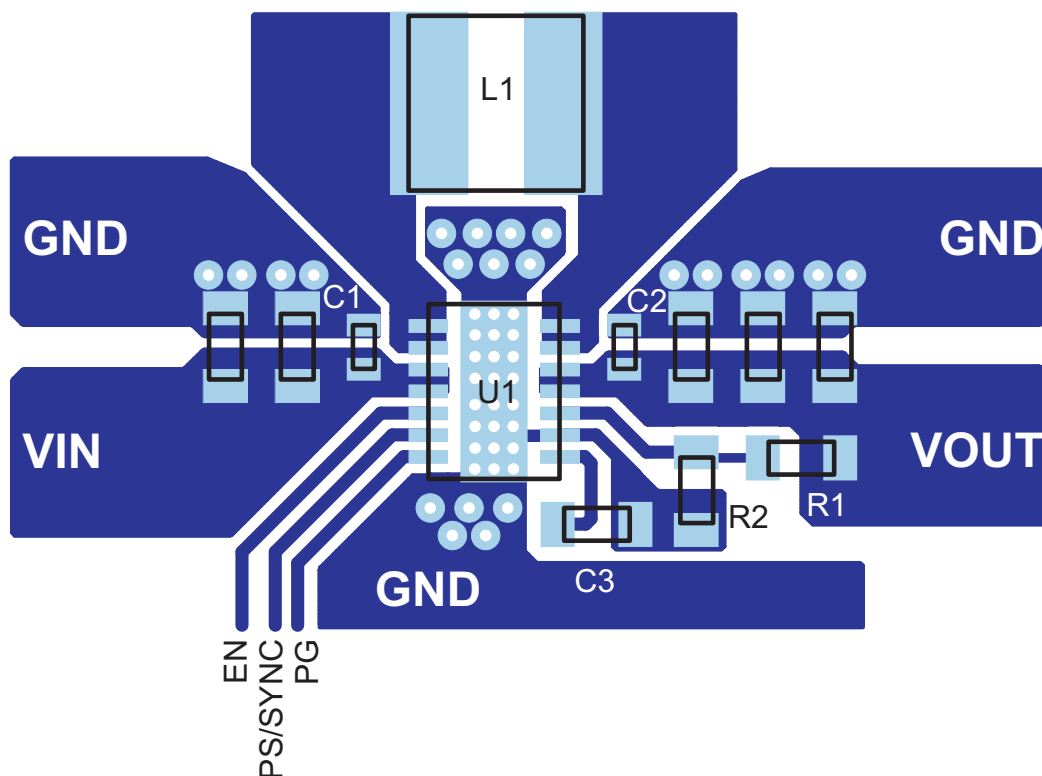

Figure 20. PCB Layout Suggestion

12.3 Thermal Considerations

Implementation of integrated circuits in low-profile and fine-pitch surface-mount packages typically requires special attention to power dissipation. Many system-dependent issues such as thermal coupling, airflow, added heat sinks and convection surfaces, and the presence of other heat-generating components affect the power-dissipation limits of a given component.

Three basic approaches for enhancing thermal performance are listed below:

- Improving the power dissipation capability of the PCB design
- Improving the thermal coupling of the component to the PCB by soldering the exposed thermal pad
- Introducing airflow in the system

For more details on how to use the thermal parameters, see the application notes: *Thermal Characteristics Application Note* ([SZZA017](#)), and *Semiconductor and IC Package Thermal Metrics Application Note* ([SPRA953](#)).

13 Device and Documentation Support

13.1 Device Support

13.1.1 Third-Party Products Disclaimer

TI'S PUBLICATION OF INFORMATION REGARDING THIRD-PARTY PRODUCTS OR SERVICES DOES NOT CONSTITUTE AN ENDORSEMENT REGARDING THE SUITABILITY OF SUCH PRODUCTS OR SERVICES OR A WARRANTY, REPRESENTATION OR ENDORSEMENT OF SUCH PRODUCTS OR SERVICES, EITHER ALONE OR IN COMBINATION WITH ANY TI PRODUCT OR SERVICE.

13.2 Documentation Support

13.2.1 Related Documentation

For related documentation see the following:

- *Thermal Characteristics Application Note*, ([SZZA017](#))
- *IC Package Thermal Metrics Application Note*, ([SPRA953](#))

13.3 Community Resources

The following links connect to TI community resources. Linked contents are provided "AS IS" by the respective contributors. They do not constitute TI specifications and do not necessarily reflect TI's views; see TI's [Terms of Use](#).

TI E2E™ Online Community *TI's Engineer-to-Engineer (E2E) Community*. Created to foster collaboration among engineers. At e2e.ti.com, you can ask questions, share knowledge, explore ideas and help solve problems with fellow engineers.

Design Support *TI's Design Support* Quickly find helpful E2E forums along with design support tools and contact information for technical support.

13.4 Trademarks

PowerPAD, E2E are trademarks of Texas Instruments.
All other trademarks are the property of their respective owners.

13.5 Electrostatic Discharge Caution



These devices have limited built-in ESD protection. The leads should be shorted together or the device placed in conductive foam during storage or handling to prevent electrostatic damage to the MOS gates.

13.6 Glossary

[SLYZ022](#) — *TI Glossary*.

This glossary lists and explains terms, acronyms, and definitions.

14 Mechanical, Packaging, and Orderable Information

The following pages include mechanical, packaging, and orderable information. This information is the most current data available for the designated devices. This data is subject to change without notice and revision of this document. For browser-based versions of this data sheet, refer to the left-hand navigation.

PACKAGING INFORMATION

Orderable Device	Status (1)	Package Type	Package Drawing	Pins	Package Qty	Eco Plan (2)	Lead/Ball Finish (6)	MSL Peak Temp (3)	Op Temp (°C)	Device Marking (4/5)	Samples
TPS63020QDSJRQ1	PREVIEW	VSON	DSJ	14	3000	Pb-Free (RoHS)	CU NIPDAU	Level-1-260C-UNLIM	-40 to 125	63020Q	

(1) The marketing status values are defined as follows:

ACTIVE: Product device recommended for new designs.

LIFEBUY: TI has announced that the device will be discontinued, and a lifetime-buy period is in effect.

NRND: Not recommended for new designs. Device is in production to support existing customers, but TI does not recommend using this part in a new design.

PREVIEW: Device has been announced but is not in production. Samples may or may not be available.

OBSELETE: TI has discontinued the production of the device.

(2) Eco Plan - The planned eco-friendly classification: Pb-Free (RoHS), Pb-Free (RoHS Exempt), or Green (RoHS & no Sb/Br) - please check <http://www.ti.com/productcontent> for the latest availability information and additional product content details.

TBD: The Pb-Free/Green conversion plan has not been defined.

Pb-Free (RoHS): TI's terms "Lead-Free" or "Pb-Free" mean semiconductor products that are compatible with the current RoHS requirements for all 6 substances, including the requirement that lead not exceed 0.1% by weight in homogeneous materials. Where designed to be soldered at high temperatures, TI Pb-Free products are suitable for use in specified lead-free processes.

Pb-Free (RoHS Exempt): This component has a RoHS exemption for either 1) lead-based flip-chip solder bumps used between the die and package, or 2) lead-based die adhesive used between the die and leadframe. The component is otherwise considered Pb-Free (RoHS compatible) as defined above.

Green (RoHS & no Sb/Br): TI defines "Green" to mean Pb-Free (RoHS compatible), and free of Bromine (Br) and Antimony (Sb) based flame retardants (Br or Sb do not exceed 0.1% by weight in homogeneous material)

(3) MSL, Peak Temp. - The Moisture Sensitivity Level rating according to the JEDEC industry standard classifications, and peak solder temperature.

(4) There may be additional marking, which relates to the logo, the lot trace code information, or the environmental category on the device.

(5) Multiple Device Markings will be inside parentheses. Only one Device Marking contained in parentheses and separated by a "~" will appear on a device. If a line is indented then it is a continuation of the previous line and the two combined represent the entire Device Marking for that device.

(6) Lead/Ball Finish - Orderable Devices may have multiple material finish options. Finish options are separated by a vertical ruled line. Lead/Ball Finish values may wrap to two lines if the finish value exceeds the maximum column width.

Important Information and Disclaimer:The information provided on this page represents TI's knowledge and belief as of the date that it is provided. TI bases its knowledge and belief on information provided by third parties, and makes no representation or warranty as to the accuracy of such information. Efforts are underway to better integrate information from third parties. TI has taken and continues to take reasonable steps to provide representative and accurate information but may not have conducted destructive testing or chemical analysis on incoming materials and chemicals. TI and TI suppliers consider certain information to be proprietary, and thus CAS numbers and other limited information may not be available for release.

In no event shall TI's liability arising out of such information exceed the total purchase price of the TI part(s) at issue in this document sold by TI to Customer on an annual basis.

OTHER QUALIFIED VERSIONS OF TPS63020-Q1 :

- Catalog: [TPS63020](#)

NOTE: Qualified Version Definitions:

- Catalog - TI's standard catalog product

MECHANICAL DATA

DSJ (R-PVSON-N14)

PLASTIC SMALL OUTLINE NO-LEAD

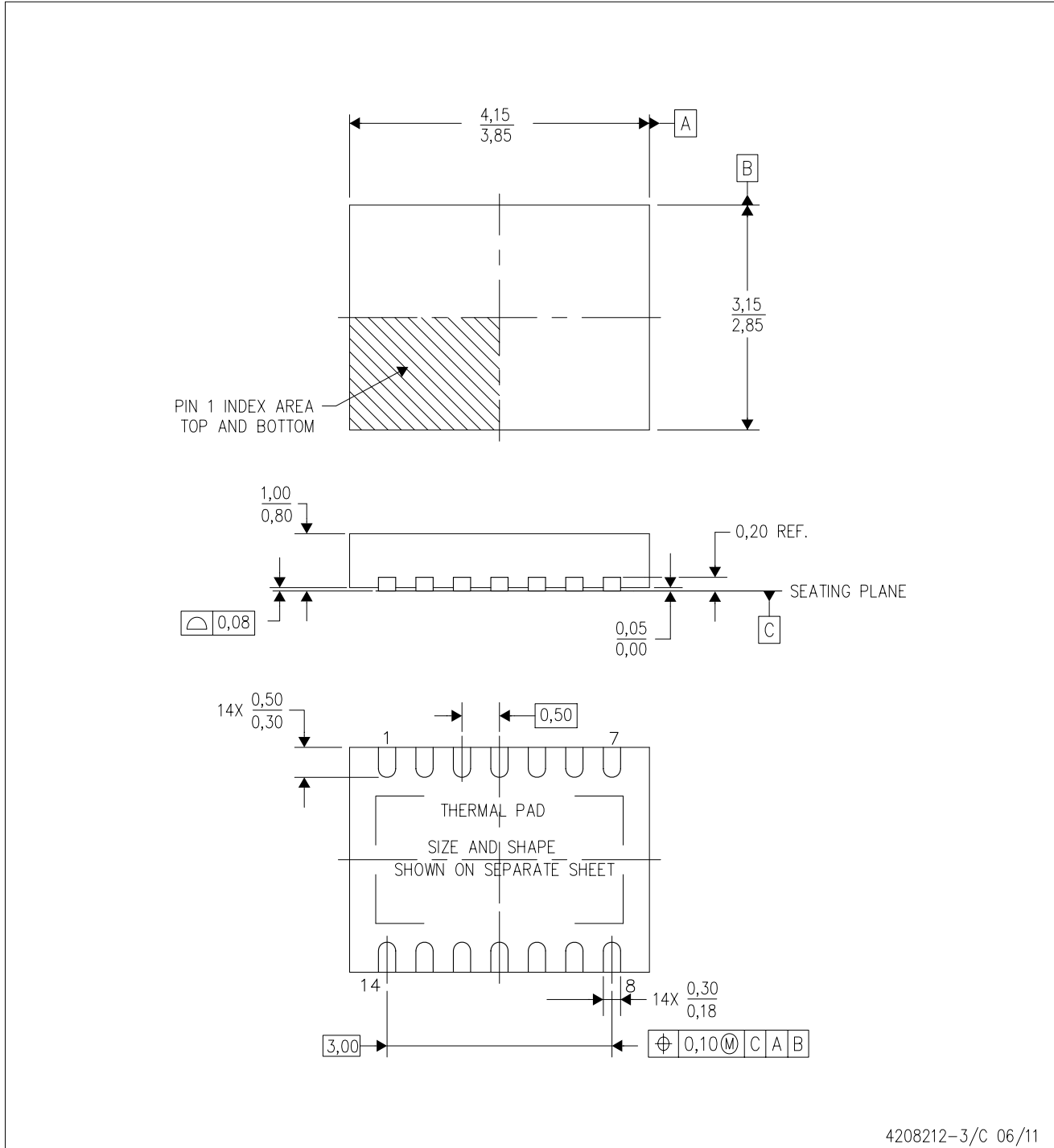

- NOTES:
- A. All linear dimensions are in millimeters. Dimensioning and tolerancing per ASME Y14.5M-1994.
 - B. This drawing is subject to change without notice.
 - C. Quad Flatpack, No-Leads (QFN) package configuration.
 - D. The package thermal pad must be soldered to the board for thermal and mechanical performance.
 - E. See the additional figure in the Product Data Sheet for details regarding the exposed thermal pad features and dimensions.

IMPORTANT NOTICE

Texas Instruments Incorporated and its subsidiaries (TI) reserve the right to make corrections, enhancements, improvements and other changes to its semiconductor products and services per JESD46, latest issue, and to discontinue any product or service per JESD48, latest issue. Buyers should obtain the latest relevant information before placing orders and should verify that such information is current and complete. All semiconductor products (also referred to herein as "components") are sold subject to TI's terms and conditions of sale supplied at the time of order acknowledgment.

TI warrants performance of its components to the specifications applicable at the time of sale, in accordance with the warranty in TI's terms and conditions of sale of semiconductor products. Testing and other quality control techniques are used to the extent TI deems necessary to support this warranty. Except where mandated by applicable law, testing of all parameters of each component is not necessarily performed.

TI assumes no liability for applications assistance or the design of Buyers' products. Buyers are responsible for their products and applications using TI components. To minimize the risks associated with Buyers' products and applications, Buyers should provide adequate design and operating safeguards.

TI does not warrant or represent that any license, either express or implied, is granted under any patent right, copyright, mask work right, or other intellectual property right relating to any combination, machine, or process in which TI components or services are used. Information published by TI regarding third-party products or services does not constitute a license to use such products or services or a warranty or endorsement thereof. Use of such information may require a license from a third party under the patents or other intellectual property of the third party, or a license from TI under the patents or other intellectual property of TI.

Reproduction of significant portions of TI information in TI data books or data sheets is permissible only if reproduction is without alteration and is accompanied by all associated warranties, conditions, limitations, and notices. TI is not responsible or liable for such altered documentation. Information of third parties may be subject to additional restrictions.

Resale of TI components or services with statements different from or beyond the parameters stated by TI for that component or service voids all express and any implied warranties for the associated TI component or service and is an unfair and deceptive business practice. TI is not responsible or liable for any such statements.

Buyer acknowledges and agrees that it is solely responsible for compliance with all legal, regulatory and safety-related requirements concerning its products, and any use of TI components in its applications, notwithstanding any applications-related information or support that may be provided by TI. Buyer represents and agrees that it has all the necessary expertise to create and implement safeguards which anticipate dangerous consequences of failures, monitor failures and their consequences, lessen the likelihood of failures that might cause harm and take appropriate remedial actions. Buyer will fully indemnify TI and its representatives against any damages arising out of the use of any TI components in safety-critical applications.

In some cases, TI components may be promoted specifically to facilitate safety-related applications. With such components, TI's goal is to help enable customers to design and create their own end-product solutions that meet applicable functional safety standards and requirements. Nonetheless, such components are subject to these terms.

No TI components are authorized for use in FDA Class III (or similar life-critical medical equipment) unless authorized officers of the parties have executed a special agreement specifically governing such use.

Only those TI components which TI has specifically designated as military grade or "enhanced plastic" are designed and intended for use in military/aerospace applications or environments. Buyer acknowledges and agrees that any military or aerospace use of TI components which have **not** been so designated is solely at the Buyer's risk, and that Buyer is solely responsible for compliance with all legal and regulatory requirements in connection with such use.

TI has specifically designated certain components as meeting ISO/TS16949 requirements, mainly for automotive use. In any case of use of non-designated products, TI will not be responsible for any failure to meet ISO/TS16949.

Products

Audio	www.ti.com/audio
Amplifiers	amplifier.ti.com
Data Converters	dataconverter.ti.com
DLP® Products	www.dlp.com
DSP	dsp.ti.com
Clocks and Timers	www.ti.com/clocks
Interface	interface.ti.com
Logic	logic.ti.com
Power Mgmt	power.ti.com
Microcontrollers	microcontroller.ti.com
RFID	www.ti-rfid.com
OMAP Applications Processors	www.ti.com/omap
Wireless Connectivity	www.ti.com/wirelessconnectivity

Applications

Automotive and Transportation	www.ti.com/automotive
Communications and Telecom	www.ti.com/communications
Computers and Peripherals	www.ti.com/computers
Consumer Electronics	www.ti.com/consumer-apps
Energy and Lighting	www.ti.com/energy
Industrial	www.ti.com/industrial
Medical	www.ti.com/medical
Security	www.ti.com/security
Space, Avionics and Defense	www.ti.com/space-avionics-defense
Video and Imaging	www.ti.com/video

TI E2E Community

e2e.ti.com