

TPS55332-Q1 2.2-MHz, 60-V Output Step Up DC/DC Converter

1 Features

- Withstands Transients up to 60 V, Boost Input Operating Range of 1.5 V to 40 V (VIN)
- Peak Internal Switch Current: 5.7 A (typ)
- 2.5 V \pm 1.5% Feedback Voltage Reference
- 80 kHz to 2.2 MHz Switching Frequency
- High Voltage Tolerant Enable Input for On/Off State
- Soft Start on Enable Cycle
- Slew Rate Control on Internal Power Switch
- External Clock Input for Synchronization
- External Compensation for Wide Bandwidth Error Amplifier
- Programmable Power on Reset Delay
- Reset Function Filter Time for Fast Negative Transients
- Programmable Undervoltage Output Monitoring, Issuance of Reset if Output Falls Below Set Threshold
- Thermal Shutdown to Protect Device During Excessive Power Dissipation
- ILIM Threshold Protection (Current Limit)
- Operating Junction Temperature Range: -40°C to 150°C
- Thermally Enhanced 20-Pin HTSSOP PowerPAD™ Package

2 Applications

- Lighting
- Battery Powered Applications
- Qualified for Automotive Applications

3 Description

The TPS55332 is a monolithic high-voltage switching regulator with integrated 3-A, 60-V power MOSFET. The device can be configured as a switch mode step-up power supply with voltage supervisor. Once the internal circuits have stabilized with a minimum input supply of 3.6 V, the system can then have an input voltage range from 1.5 V to 40 V, to maintain a fixed boost output voltage. For optimum performance, VIN/Vout ratios should be set such that the minimum required duty cycle pulse > 150 ns. The supervisor circuit monitors the regulated output and indicates when this output voltage has fallen below the set value. The TPS55332 has a switching frequency range from 80 kHz to 2.2 MHz, allowing the use of low profile inductors and low value input and output capacitors. The external loop compensation gives the user the flexibility to optimize the converter response for the appropriate operating conditions. Using the enable pin (EN), the shutdown supply current is reduced to 1 μA . The device has built-in protection features such soft start on enable cycle, pulse-by-pulse current limit, and thermal sensing and shutdown due to excessive power dissipation.

Device Information⁽¹⁾

PART NUMBER	PACKAGE	BODY SIZE (NOM)
TPS55332	HTSSOP (20)	6.50 mm x 4.40 mm

(1) For all available packages, see the orderable addendum at the end of the datasheet.

Simplified Schematic

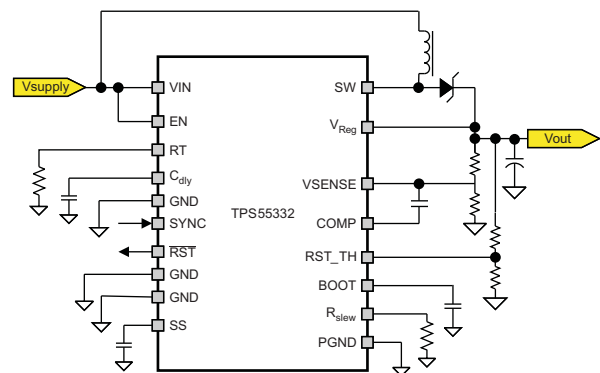

S0401-01



Table of Contents

1 Features	1	7.3 Feature Description	9
2 Applications	1	7.4 Device Functional Modes	13
3 Description	1	8 Application and Implementation	17
4 Revision History	2	8.1 Application Information	17
5 Pin Configuration and Functions	3	8.2 Typical Application	17
6 Specifications	4	9 Power Supply Recommendations	22
6.1 Absolute Maximum Ratings	4	10 Layout	23
6.2 ESD Ratings	4	10.1 Layout Guidelines	23
6.3 Recommended Operating Conditions	4	10.2 Layout Example	24
6.4 Thermal Information	5	10.3 Power Dissipation	26
6.5 Electrical Characteristics	5	11 Device and Documentation Support	28
6.6 Typical Characteristics	7	11.1 Trademarks	28
7 Detailed Description	8	11.2 Electrostatic Discharge Caution	28
7.1 Overview	8	11.3 Glossary	28
7.2 Functional Block Diagram	8	12 Mechanical, Packaging, and Orderable Information	28

4 Revision History

NOTE: Page numbers for previous revisions may differ from page numbers in the current version.

Changes from Revision A (June 2010) to Revision B	Page
<ul style="list-style-type: none"> Added <i>ESD Ratings</i> table, <i>Feature Description</i> section, <i>Device Functional Modes</i>, <i>Application and Implementation</i> section, <i>Power Supply Recommendations</i> section, <i>Layout</i> section, <i>Device and Documentation Support</i> section, and <i>Mechanical, Packaging, and Orderable Information</i> section 	4

Changes from Original (June 2009) to Revision A	Page
<ul style="list-style-type: none"> Changed title from 0.5-A, 60-V STEP UP DC/DC CONVERTER to 2.2-MHz, 60-V OUTPUT STEP UP DC/DC CONVERTER 	1
<ul style="list-style-type: none"> Added Peak Internal Switch Current: 5.7 A (typ) to Features 	1
<ul style="list-style-type: none"> Deleted Asynchronous Switch Mode Regulator with External Components (L and C), Output up to 0.5 A (max) in Boost Mode from Features 	1
<ul style="list-style-type: none"> Added $f_{sw} < f_{ext} < 2 \times f_{sw}$ to SYNC input clock test conditions 	5
<ul style="list-style-type: none"> Changed SYNC input clock max value from 1100 kHz to 2200 kHz 	5
<ul style="list-style-type: none"> Added $V_{out} = 25.5V$ to test conditions 	5
<ul style="list-style-type: none"> Added $V_{out} = 25.5V$ to test conditions 	5
<ul style="list-style-type: none"> Changed Output Voltage (V_{out}) description 	9
<ul style="list-style-type: none"> Changed internal reference V_{ref} from 2.5 V to 0.8 V 	12
<ul style="list-style-type: none"> Added inductor saturation current I_{sat} description 	13

5 Pin Configuration and Functions

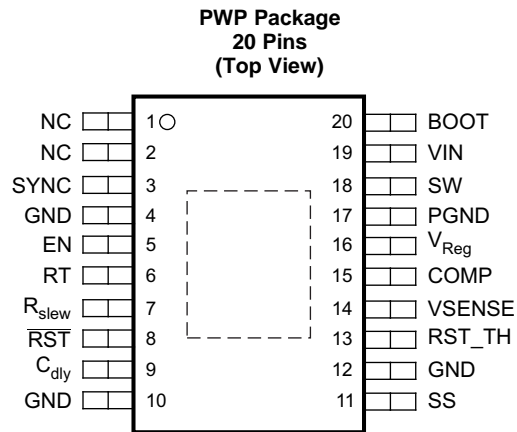

P0021-03

Pin Functions

PIN		I/O	DESCRIPTION
NAME	NO.		
NC	1	NC	Connect to ground
NC	2	NC	Connect to ground
SYNC	3	I	External synchronization clock input, 62-kΩ (typ) pull-down resistor
GND	4	I	Connect to ground
EN	5	I	Enable input, high voltage tolerant
RT	6	O	Resistor to program internal oscillator frequency
R _{slew}	7	O	Internal switch programmable slew rate control
RST	8	O	Reset output open drain (active low)
C _{dly}	9	O	Reset delay timer (programmed by external capacitor)
GND	10	O	Analog ground, DVSS and SUB
SS	11	O	Programmable soft-start. (external capacitor)
GND	12	I	Connect to ground
RST_TH	13	I	Input for RESET circuitry to detect undervoltage on output (adjustable threshold)
VSENSE	14	I	Feedback input for voltage mode control
COMP	15	O	Error amplifier output
V _{Reg}	16	I	Internal low side FET to load output during start up or limit over shoot
PGND	17	O	Power ground connection
SW	18	I/O	Switched drain output/input
VIN	19	I	Unregulated input voltage
BOOT	20	O	Bootstrap capacitor pump

6 Specifications

6.1 Absolute Maximum Ratings

 over operating free-air temperature range (unless otherwise noted) ⁽¹⁾

		MIN	MAX	UNIT
V _I	Unregulated input voltages (VIN, EN) ⁽²⁾ (SW) ⁽²⁾⁽³⁾	-0.3	60	V
	Unregulated input voltages (BOOT)	-0.3	8	V
V _{Reg}	Regulated voltage	-0.3	60	V
	Logic level signals (RT, $\overline{\text{RST}}$, SYNC, VSENSE, RST_TH) ⁽²⁾	-0.3	5.5	V
	Logic level signals (SS, Cdly) ⁽²⁾	-0.3	8	V
	Logic level signals (COMP) ⁽²⁾	-0.3	7	V
T _J	Operating virtual junction temperature range	-40	150	°C
T _{stg}	Storage temperature	-55	165	°C

(1) Stresses beyond those listed under *Absolute Maximum Ratings* may cause permanent damage to the device. These are stress ratings only, which do not imply functional operation of the device at these or any other conditions beyond those indicated under *Recommended Operating Conditions*. Exposure to absolute-maximum-rated conditions for extended periods may affect device reliability.

(2) All voltage values are with respect to GND.

(3) Absolute negative voltage on these pins not to go below -0.6 V.

6.2 ESD Ratings

			VALUE	UNIT	
V _(ESD)	Electrostatic discharge	Human body model (HBM), per AEC Q100-002 ⁽¹⁾	±2000	V	
		Charged device model (CDM), per AEC Q100-011	Corner pins (NC, BOOT, SS, and GND)		±750
			Other pins		±500

(1) AEC Q100-002 indicates HBM stressing is done in accordance with the ANSI/ESDA/JEDEC JS-001 specification.

6.3 Recommended Operating Conditions

		MIN	NOM	MAX	UNIT
V _I	Unregulated buck supply input voltage (VIN, EN)	3.6		40	V
V _{Reg}	Output voltage range	2.5		50	V
	Bootstrap capacitor (BOOT)	3.6		8	V
	Switched outputs (SW)	3.6		52	V
	Logic level inputs ($\overline{\text{RST}}$, VSENSE, RST_TH, Rslew, SYNC, RT)	0		5.25	V
	Logic level inputs (SS, Cdly, COMP)	0		6.5	V
θ _{JA}	Thermal resistance, junction to ambient ⁽¹⁾			35	°C/W
θ _{JC}	Thermal resistance, junction to case ⁽²⁾			10	°C/W
T _J	Operating junction, temperature range ⁽³⁾	-40		150	°C

(1) This assumes a JEDEC JESD 51-5 standard board with thermal vias and high-K profile – See PowerPAD section and application note from Texas Instruments ([SLMA002](#)) for more information.

(2) This assumes junction to exposed PAD.

(3) This assumes $T_A = T_J - \text{power dissipation} \times \theta_{JA}$ (junction to ambient).

6.4 Thermal Information

THERMAL METRIC ⁽¹⁾		TPS55332-Q1	UNIT
		PWP 20 PINS	
R _{θJA}	Junction-to-ambient thermal resistance	43.8	°C/W
R _{θJC(top)}	Junction-to-case (top) thermal resistance	21.4	
R _{θJB}	Junction-to-board thermal resistance	18.5	
ψ _{JT}	Junction-to-top characterization parameter	0.5	
ψ _{JB}	Junction-to-board characterization parameter	18.3	
R _{θJC(bot)}	Junction-to-case (bottom) thermal resistance	1.2	

(1) For more information about traditional and new thermal metrics, see the *IC Package Thermal Metrics* application report, [SPRA953](#).

6.5 Electrical Characteristics

V_{IN} = 7 V to 40 V, EN = High, T_J = –40°C to 150°C (unless otherwise noted)

TEST	PARAMETER		TEST CONDITIONS	MIN	TYP	MAX	UNIT
INPUT VOLTAGE (VIN)							
Info	V _{IN}	Supply voltage on VIN line	Normal mode – buck mode after start up	1.5		40	V
PT	I _{q-Normal}	Bias current, normal mode			4.2	8	mA
PT	I _{SD}	Shutdown	EN = 0 V, V _{IN} = 12 V, T _A = 25°C		2	4	μA
SWITCH MODE SUPPLY; VReg/Vout							
Info	V _{Reg}	Regulator output	V _{SENSE} = 2.5 V in boost mode ⁽¹⁾	V _{in} × 1.05		50	V
CT	V _{SENSE}	Feedback voltage	V _{IN} = 12 V	2.463	2.5	2.538	V
PT	R _{DS(on)}	Internal switch resistance	Measured across V _{SWD} and GND			500	mΩ
Info	I _{CL}	Switch current limit	V _{IN} = 7 V to 28 V		5.7		A
Info	t _{ON-Min}	Duty cycle pulse width	Bench mode = 500 kHz	50	100	150	ns
	t _{OFF-Min}			50	100	150	
PT	f _{sw}	Switch mode frequency	Set using external resistor on RT pin	80		2200	kHz
PT	f _{sw}	Internal oscillator frequency		–10%		10%	
ENABLE (EN)							
PT	V _{IL}	Low input threshold				0.7	V
PT	V _{IH}	High input threshold		1.7			V
PT	I _{Leakage}	Leakage into EN terminal	EN = 24 V		35		μA
RESET DELAY (CDLY)							
PT	I _O	External capacitor charge current	EN = high	1.4	2	2.6	μA
PT	V _{Threshold}	Switching threshold	Output voltage in regulation	1.8	2	2.4	V
RESET OUTPUT (RST)							
Info	t _{rdly}	POR delay timer	Based on Cdly capacitor, Cdly = 4.7 nF	3.6		7	ms
PT	RST_TH	Reset threshold for V _{Reg}	Check RST output	0.768		0.832	V
PT	t _{RSTdly}	Filter time	Once VRST_TH or OV_TH is detected, delay before RST is asserted low	10	20	35	μs
SYNCHRONIZATION (SYNC)							
PT	V _{SYNC}	Low-level input voltage, V _{IL}				0.7	V
PT		High-level input voltage, V _{IH}		1.7			V
PT	I _{Leakage}	Leakage current	SYNC = 5 V		65	95	μA
PT	SYNC	Input clock	V _{IN} = 12 V, f _{sw} < f _{ext} < 2 × f _{sw}	80		2200	kHz
Info	SYNC _{trans}	External clock to internal clock	No external clock, V _{IN} = 12 V		32		μs
Info	SYNC _{trans}	Internal clock to external clock	External clock = 500 kHz, V _{IN} = 12 V		2.5		μs
CT	SYNC _{CLK}	Minimum duty cycle		30%			

(1) Voltage ratio of input to output in boost mode is 1:10 (max) and up to 50 V output max.

TPS55332-Q1

SLVS939B – JUNE 2009 – REVISED DECEMBER 2014

www.ti.com
Electrical Characteristics (continued)

 VIN = 7 V to 40 V, EN = High, T_J = –40°C to 150°C (unless otherwise noted)

TEST	PARAMETER		TEST CONDITIONS	MIN	TYP	MAX	UNIT
CT	SYNC _{CLK}	Maximum duty cycle				70%	
R_{slew}							
CT	I _{R_{slew}}	Slew current	R _{slew} = 50 kΩ, Calculated not measured		20		μA
CT	I _{R_{slew}}	Slew current	R _{slew} = 50 kΩ, Calculated not measured		100		μA
Soft Start (SS)							
PT	I _{SS}	Soft start current		40	50	60	μA
THERMAL SHUTDOWN							
CT	T _{SD}	Thermal shutdown junction temperature			175	200	°C
CT	T _{HYS}	Hysteresis			30		°C
PT: Production tested CT: Characterization tested only, not production tested Info: User Information only, not production tested							

6.6 Typical Characteristics

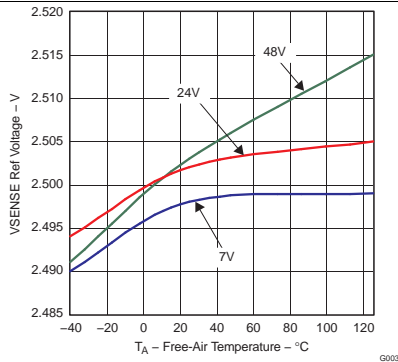

Figure 1. Vsense Ref Voltage (V) vs Temperature (°C)

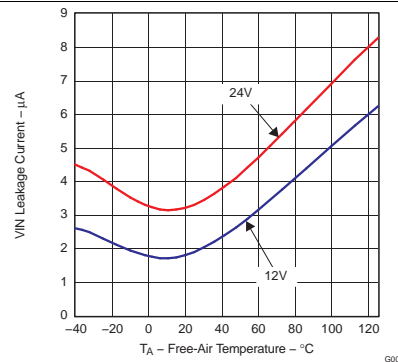

Figure 2. VIN Leakage Current (Ma) vs Temperature (°C)

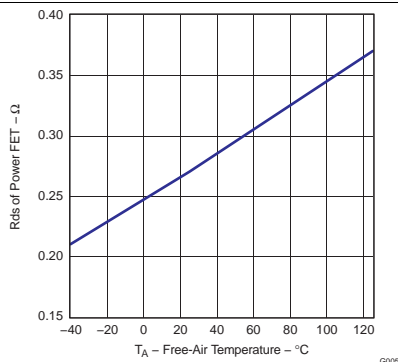

Figure 3. Rds Of Power Fet (Ω) vs Temperature (°C)

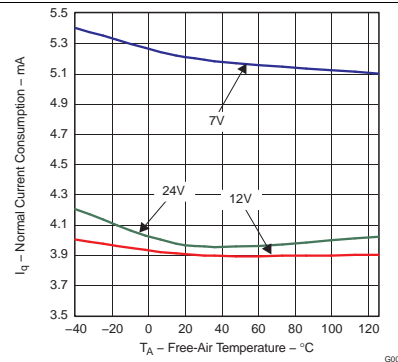

Figure 4. Normal Current Consumption (mA) vs Temperature (°C)

7 Detailed Description

7.1 Overview

The TPS55332 operates as a step up (boost) converter; the feedback concept is voltage mode control using the VSENSE terminal, with cycle-by-cycle current limit.

The voltage supervisory function for power-on-rest during system power-on is monitoring the output voltage, and once this has exceeded the threshold set by RST_TH, a delay of 1.0 ms/nF (based on the capacitor value on the Cdly terminal) is invoked before the RST line is released high. Conversely, on power down, once the output voltage falls below the same set threshold (ignoring hysteresis), RST is pulled low only after a de-glitch filter of approximately 20 μs (typ) expires. This is implemented to prevent RST from being triggered due to fast transient noise on the output supply.

Soft start is activated on every enable cycle and limits the power stored in the inductor by duty cycle control. Soft start duration is set by an external capacitor on the SS terminal.

If thermal shutdown is invoked due to excessive power dissipation, the internal switch is disabled and the regulated output voltage starts to decrease. Depending on the load line, the regulated voltage can decay and the RST_TH threshold may assert RST output low after the output voltage drops below the set threshold.

7.2 Functional Block Diagram

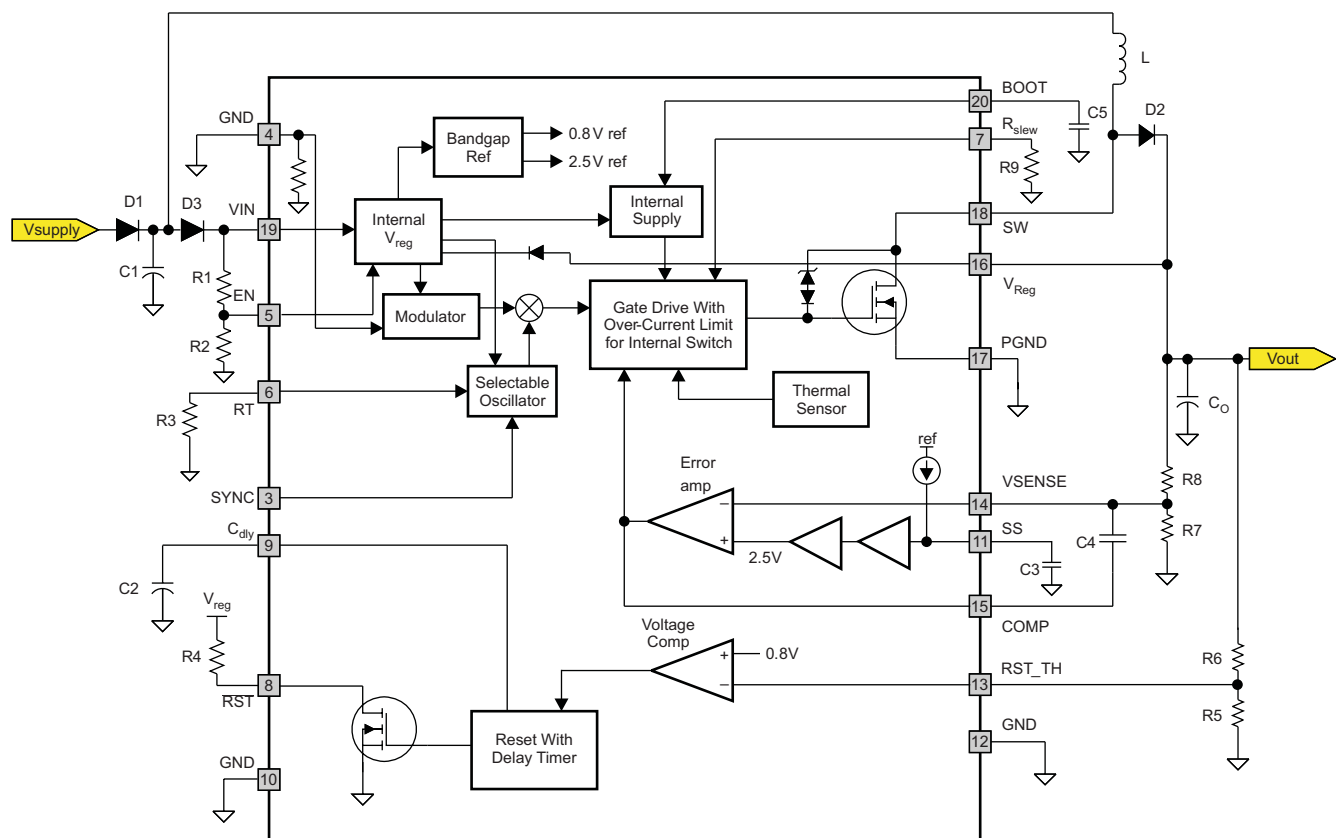

B0354-01

NOTE: An integrated forward biased diode is between VReg and VIN. VReg is tied to Vout and used to bias VIN when Vout > Vsupply. However, the minimum Vsupply operating voltage at power-up (when Vout < Vsupply) is 3.6 V + 2 diode drops. After power-up (when Vout > Vsupply) the minimum Vsupply = 1.5 V + 2 diode drops. VReg < 5.8 V and VIN < 3.6 V. Converter non-operational.

NOTE: VIN is the voltage at VIN before VReg > Vsupply.

7.3 Feature Description

The TPS55332 is a step up (boost) dc/dc converter using voltage-control mode scheme. The following sections include descriptions of the individual pin functions.

7.3.1 Input Voltage (VIN)

The VIN pin is the input power source for the TPS55332. This pin must be externally protected against voltage level transients greater than 60 V and reverse battery. In boost mode the input current drawn from this pin is pulsed, with fast rise and fall times. Therefore, this input line requires a filter capacitor to minimize noise. Additionally, for EMI considerations, an input filter inductor may also be required.

7.3.2 Output Voltage (Vout)

The output voltage, Vout, is generated by the converter supplied from the battery voltage VIN and external components (L, C). The output is sensed through an external resistor divider and compared with an internal reference voltage.

The value of the adjustable output voltage in boost mode is selectable between $V_{IN} \times 1.05$ to 50 V if the minimum ON time (t_{on}) and minimum OFF times are NOT violated by choosing the external resistors, according to the following relationship:

$$V_{out} = V_{ref} \left(1 + \frac{R8}{R7} \right) \quad (\text{Volts}) \quad (1)$$

Where:

R7 and R8 are feedback resistors
 $V_{ref} = 2.5 \text{ V (typ)}$

The internal reference voltage Vref has a $\pm 1.5\%$ tolerance. The overall output voltage tolerance is dependent on the external feedback resistors. To determine the overall output voltage tolerance, use the following relationship:

$$tol_{V_{out}} = tol_{V_{ref}} + \left(\frac{R8}{R8+R7} \right) \times (tol_{R8} + tol_{R7}) \quad (2)$$

Typically, an output capacitor within the range of 10 μF to 400 μF is used. This terminal has a filter capacitor with low ESR characteristics in order to minimize output ripple voltage.

7.3.3 Regulated Supply Voltage (VReg)

There is an integrated forward biased diode between V_{Reg} and VIN. V_{Reg} is tied to Vout and used to bias VIN when $V_{out} > V_{supply}$.

7.3.4 Over-Current Protection (SW)

Over-current protection is implemented by sensing the current through the NMOS switch FET. The sensed current is then compared to a current reference level representing the over-current threshold limit. If the sensed current exceeds the over-current threshold limit, the over-current indicator is set true. The system ignores the over-current indicator for the leading edge blanking time at the beginning of each cycle to avoid any turn-on noise glitches.

Once the over-current indicator is set true, over-current protection is triggered. The MOSFET is turned off for the rest of the cycle after a propagation delay. The over-current protection scheme is called cycle-by-cycle current limiting. If the sensed current continues to increase during cycle-by-cycle current limiting, the temperature of the device starts to rise, and the TSD kicks in and shuts down switching until the device cools down.

7.3.5 Oscillator Frequency (RT)

The oscillator frequency is selectable by means of a resistor placed at the RT pin. The switching frequency (f_{sw}) can be set in the range of 80 kHz to 2.2 MHz. In addition, the switching frequency can be imposed externally by a clock signal (f_{ext}) at the SYNC pin with $f_{sw} < f_{ext} < 2 \times f_{sw}$. In this case the external clock overrides the switching frequency determined by the RT pin, and the internal oscillator is clocked by the external synchronization clock input.

Feature Description (continued)

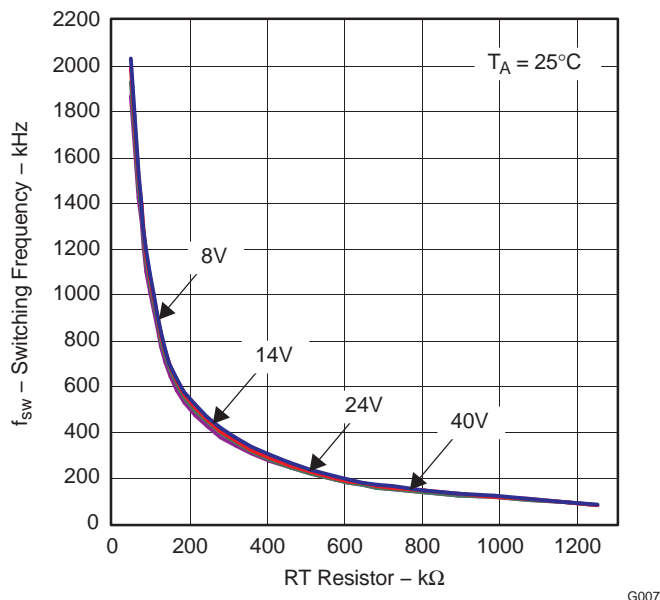

Figure 5. Oscillator Frequency (RT)

7.3.6 Enable / Shutdown (EN)

The Enable pin provides electrical on/off control of the regulator. Once the Enable pin voltage exceeds the threshold voltage, the regulator starts operation and the internal soft start begins to ramp. If the Enable pin voltage is pulled below the threshold voltage, the regulator stops switching and the internal soft start resets. Connecting the pin to ground or to any voltage less than 0.7 V disables the regulator and activates shutdown mode. The quiescent current of the TPS55332 in shutdown mode is typically $< 2 \mu\text{A}$. This pin has to have an external pull up or pull down to change the state of the device.

7.3.7 Reset Delay (C_{dly})

The Reset delay pin sets the desired delay time for asserting the $\overline{\text{RST}}$ pin high after the supply has exceeded the programmed V_{reg_RST} voltage. The delay may be programmed in the range of 2.2 ms to 200 ms using capacitors in the range of 2.2 nF to 200 nF. The delay time is calculated using [Equation 3](#):

$$t_{delay} = t_{rdly} \times C = \left(\frac{1 \text{ ms}}{\text{nF}} \right) \times C, \text{ Where } C = \text{capacitor on } C_{dly} \text{ pin} \quad (3)$$

7.3.8 Reset Pin ($\overline{\text{RST}}$)

The $\overline{\text{RST}}$ pin is an open-drain output. The power-on reset output is asserted low until the output voltage exceeds the programmed V_{reg_RST} voltage threshold and the reset delay timer has expired. Additionally, whenever the Enable pin is low or open, $\overline{\text{RST}}$ is immediately asserted low regardless of the output voltage. There is a reset de-glitch timer to prevent a reset being invoked due to short negative transients on the output line. If a thermal shut down occurs due to excessive thermal conditions this pin is asserted low, where switching is commanded off and the output drops below the rest threshold set on the RST_TH terminal.

Feature Description (continued)

Power On Condition/Reset Line

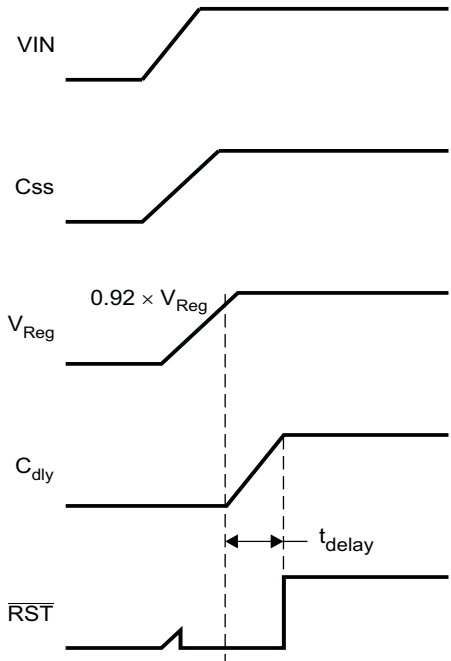

Power Down Condition/Reset Line

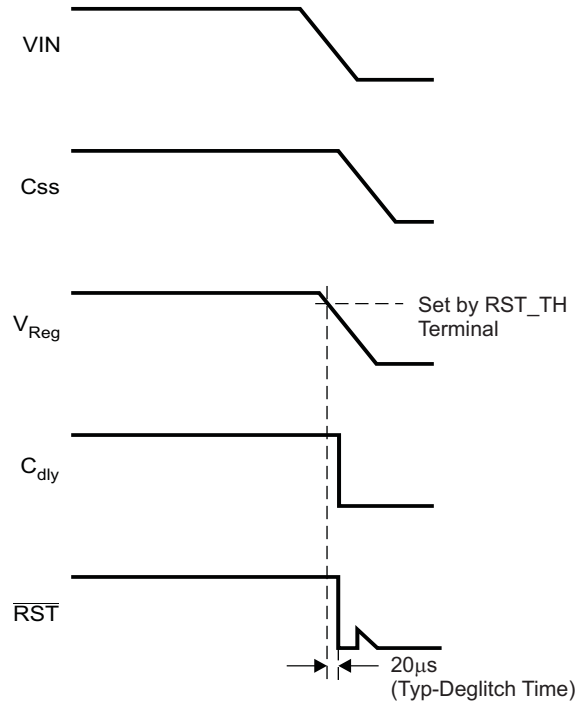

T0435-01

Figure 6. Reset Line Conditions

7.3.9 Boost Capacitor (BOOT)

This capacitor provides gate drive voltage for the Internal MOSFET switch. X7R or X5R grade dielectrics are recommended due to their stable values over temperature.

7.3.10 Soft Start (SS)

To limit the start-up inrush current, an internal soft start circuit is used to ramp up the reference voltage from 0 V to its final value. The switch duty cycle starts with narrow pulses and increases gradually as the voltage on the C_{SS} capacitor ramps up. The output current on this pin charges the capacitor up to 6.6 V (typ).

The boost soft start is dependent on the gain bandwidth (GBW) of the loop. Therefore, in this configuration the C_{SS} equation only holds when:

$$\frac{1}{\text{GBW}} < 10 \times T_{\text{CSS}} \tag{4}$$

GBW is dependent on the compensation technique used. TYPE1 is the slowest.

Where:

T_{CSS} is the time it takes for V_{CSS} to reach ~3.5 V

GBW = f_c of the converter

$$\text{Time } (T_{\text{CSS}}) = \frac{C \times 3.5}{40 \times 10^{-6}} \quad (\text{sec}) \tag{5}$$

Where:

C = Capacitor C_{SS} on the SS pin

Feature Description (continued)

7.3.11 Synchronization (SYNC)

The SYNC pin inputs an external clock signal that synchronizes the switching frequency. The synchronization input over-rides the internally fixed oscillator signal. The synchronization signal has to be valid for approximately 2 clock cycles (pulses) before the transition is made for synchronization with the external frequency input. If the external clock input is does NOT transition low or high for 32 μs (typ), the system defaults to the internal clock set by the **Rosc pin**.

7.3.12 Regulation Voltage (VSENSE)

This pin is used to program the regulated output voltage based on a resistor feedback network monitoring the V_{out} voltage. The selected ratio of R7 and R8 sets the output voltage.

7.3.13 Reset Threshold (RST_TH)

This pin is programmable to set the under-voltage monitoring of the regulated output voltage. The resistor combination of R5 and R6 is used to program the threshold for detection of under-voltage.

$$\text{Reset Threshold} = \text{RST_TH} = V_{\text{ref}} (1 + (R6/R5)), \tag{6}$$

Recommended range: 70% to 92% of the regulation voltage

The internal reference V_{ref} is set at 0.8 V $\pm 1.5\%$

7.3.14 Slew Rate Control (Rslw)

This pin controls the switching slew rate of the internal power NMOS. The slew rate is set by an external resistor with a slew rate range shown for rise and fall times. The range of rise time $t_r = 20$ ns to 60 ns and fall time $t_f = 60$ ns to 250 ns, with R_{slew} range of 5 k Ω to 20 k Ω (see [Figure 7](#) and [Figure 8](#)).

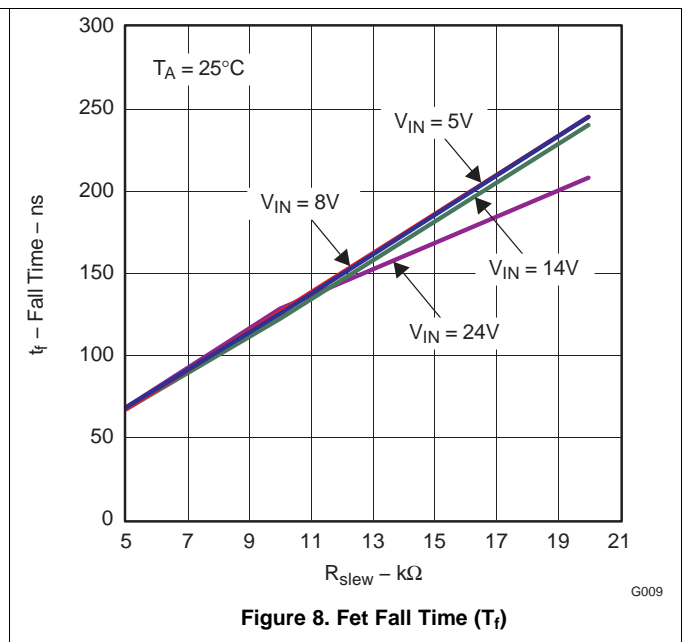
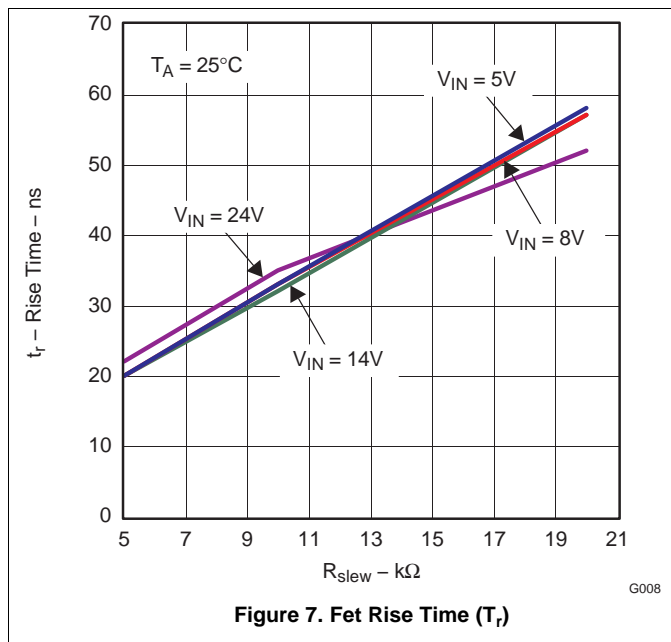

7.3.15 Thermal Shutdown

The TPS55332 device protects itself from overheating with an internal thermal shutdown circuit. If the junction temperature exceeds the thermal shutdown trip point, the MOSFET is turned off. The device is restarted under control of the slow start circuit automatically when the junction temperature drops below the thermal shutdown hysteresis trip point.

Feature Description (continued)

7.3.16 Loop Control Frequency Compensation

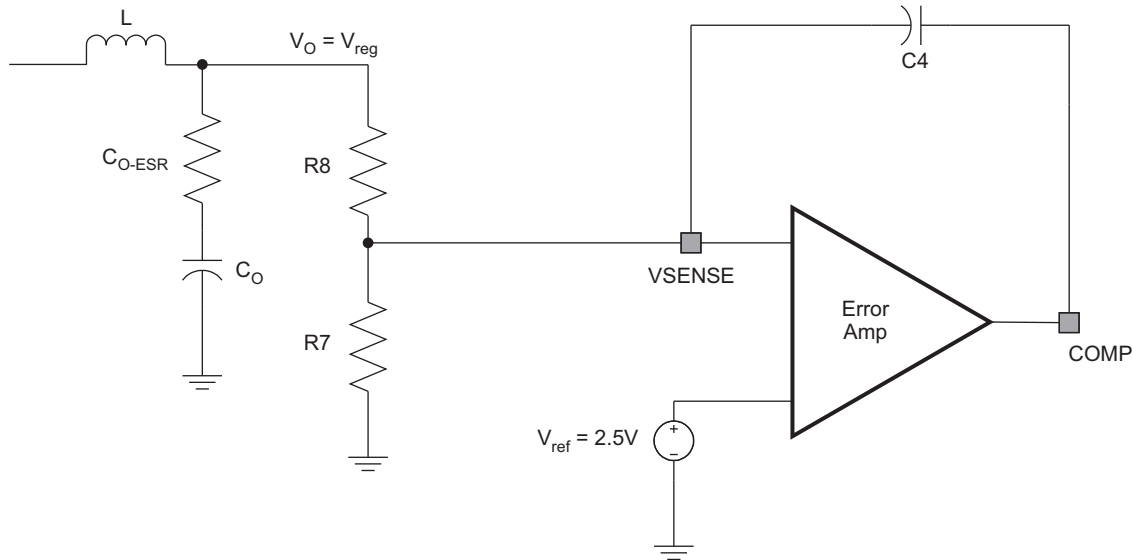

S0402-01

Figure 9. Type 1 Compensation

The boost converter operating in continuous conduction mode (CCM) has a right-half-plane (RHP) zero with the transfer function. The RHP zero causes the converter to respond to a circuit disturbance in the opposite direction to that needed to support the output load transition (positive feedback). This complicates loop compensation and limits the converter bandwidth, and requires an increase in the output filter capacitor.

The converter can be designed to operate in discontinuous conduction mode (DCM) with a smaller inductance value for the inductor over the full range of the operating conditions. This may be difficult to achieve and other issues like instability may occur if the converter enters CCM.

The inductor saturation current I_{sat} must satisfy the following:

$$I_{sat} > \frac{I_{Load}}{D \times \text{efficiency}} + \left(\frac{V_{IN}}{L} \right) \times 15\mu\text{s} \quad (7)$$

Where:

$$D = V_{IN}/V_O$$

The converter designed for CCM with external loop compensation factors the maximum output load current, the ESR of the output filter capacitor, the inductance used for the inductor, the input voltage range, and the output voltage required.

7.4 Device Functional Modes

7.4.1 DCM Operation

The control to output transfer function for the boost in DCM has a single pole. The energy in the inductor is completely discharged during every switching cycle (inductor current is reduced to zero). The small inductor value for DCM compared to CCM operation shifts the RHP zero frequency close to the switching frequency, see [Equation 11](#). In this mode, the RHP is not a factor for compensation of the feedback loop, additionally the frequency of the pole associated with the inductor is also increased to a higher frequency.

The maximum inductance to keep the boost converter running in DCM over the full operating range is given by [Equation 8](#):

Device Functional Modes (continued)

$$L_{\max} = \frac{0.8 \times D_{\text{CCM}} \times (1 - D_{\text{CCM}})^2 \times \left(\frac{V_O}{I_O}\right)}{2 \times f_{\text{sw}}} \quad (\text{Henries}) \quad (8)$$

Where:

$$D_{\text{CCM}} = 1 - \left(\frac{V_{\text{IN}}}{V_O}\right) \quad (9)$$

V_O = Output voltage

I_O = Maximum output current

V_{IN} = Minimum input voltage

Three elements of the output capacitor contribute to the impedance (output voltage ripple), ESR, ESL, and capacitance.

During discontinuous conduction mode operation, the minimum capacitance needed to limit the voltage ripple due to the capacitance of the capacitor is given by [Equation 10](#):

$$C_{\text{dcm-min}} \geq \frac{I_{\text{O(max)}} \times \left[1 - \sqrt{\frac{2 \times L}{R \times T_s}}\right]}{f_{\text{sw}} \times \Delta V_O} \quad (\text{Farads}) \quad (10)$$

Where:

R = min load resistance,

T_s = clock period,

f_{sw} = switching frequency,

ΔV_O = output voltage ripple desired

The ESR of the output capacitor needed to limit the output ripple voltage is given by [Equation 11](#):

$$\text{ESR} \leq \frac{\Delta V_O}{\Delta I_O} \quad (\text{Ohms}) \quad (11)$$

7.4.2 CCM Operation

In continuous conduction mode of operation the RHP zero complicates the loop compensation. This limits the bandwidth of the converter and may require a larger value output filter capacitor to compensate for loop response. The benefit of this mode is a lower switch and inductor current compared to DCM. This results in reduced power dissipation and size of the power switch, input capacitor, and output capacitor. The output filter capacitor value may need to be increased such that

$$f_{\text{LC}} \leq 0.1 f_{\text{RHP}}$$

The following requirements for compensating the loop have to be satisfied for the control-to-output gain of a CCM boost operation.

$$f_{\text{LC}} = 0.1 \times f_{\text{RHP-zero}} \quad (12)$$

$$\frac{f_{\text{RHP-zero}}}{f_{\text{LC}}} > M \quad (13)$$

Where:

$M = 10$ – for tantalum capacitors

$M = 15$ – for ceramic capacitors

$$f_C = 0.33 \times f_{\text{RHP-zero}} \quad (14)$$

$$f_{\text{LC}} = \frac{1}{2\pi \sqrt{LC_O}} \times \frac{V_{\text{IN}}}{V_O} \quad (\text{Hz}) \quad (15)$$

Device Functional Modes (continued)

Where:

L = Inductor value,
 Co = Output capacitor,
 V_{IN} = Input voltage, and
 V_O = Output voltage

$$f_{\text{RHP-zero}} = \frac{R}{2\pi L} \times \left(\frac{V_{\text{IN}}}{V_{\text{O}}} \right)^2 \quad (\text{Hz}) \quad (16)$$

$$f_{\text{ESR}} = \frac{R}{2\pi C_{\text{O}} \times \text{ESR}} \quad (\text{Hz}) \quad (17)$$

The feed-forward compensation network type 1 is calculated using the pole frequency in [Equation 18](#):

$$f_{\text{p}} = \frac{1}{2\pi C_4 R_8} \quad (\text{Hz}) \quad (18)$$

The minimum output capacitor required for a desired output ripple voltage is given by [Equation 19](#):

$$C_{(\text{ccm min})} \geq \frac{I_{\text{O(max)}}}{\Delta V_{\text{O}}} \left(1 - \frac{V_{\text{IN}}}{V_{\text{O}}} \right) \frac{1}{f_{\text{sw}}} \quad (\text{Farads}) \quad (19)$$

The minimum inductor value needed to ensure CCM from maximum to 25% of maximum load is determined by choosing the value of the inductor to have a ripple current of approximately 40% of the maximum output load current at maximum input voltage of the system.

$$\Delta I_{\text{L}} = 0.4 \times I_{\text{O}} \quad (\text{Amperes}) \text{ for } V_{\text{IN-max}} \quad (20)$$

To maintain ccm operation with at least a 10% of maximum load current ($I_{\text{O-DLM}} \geq 0.1 \times I_{\text{O-max}}$) The inductor is given by [Equation 21](#):

$$L = \frac{V_{\text{IN}}}{2 \times I_{\text{O-Dccm}} \times f_{\text{sw}}} \times D_{\text{ccm}} \times (1 - D_{\text{ccm}}) \quad (\text{Henries}) \quad (21)$$

Where:

D_{ccm} = 0.5,
 V_{IN} = Typical operating voltage

Choosing an inductor value less than the one determined by [Equation 21](#) may cause the converter to go into DCM operation during low output currents. This may not be a problem if the loop compensation allows for good phase margin.

The ripple current flowing through the output capacitor ESR causes power dissipation in the capacitor. [Equation 17](#) gives the RMS value of the ripple current flowing through the output capacitance.

$$I_{\text{CRMS}} = I_{\text{O}} \times \sqrt{\frac{D}{1 - D}} \quad (22)$$

Where:

D = Duty cycle

For continuous inductor current mode operation, the ESR needed to limit the ripple voltage ΔV_{O} to volts peak-peak is:

$$\text{ESR} \leq \frac{\Delta V_{\text{O}}}{\frac{I_{\text{O(max)}}}{1 - D_{\text{max}}} + \frac{\Delta I_{\text{O}}}{2}} \quad (\text{Ohms}) \quad (23)$$

Device Functional Modes (continued)

7.4.3 Loop Compensation For Stability Criteria

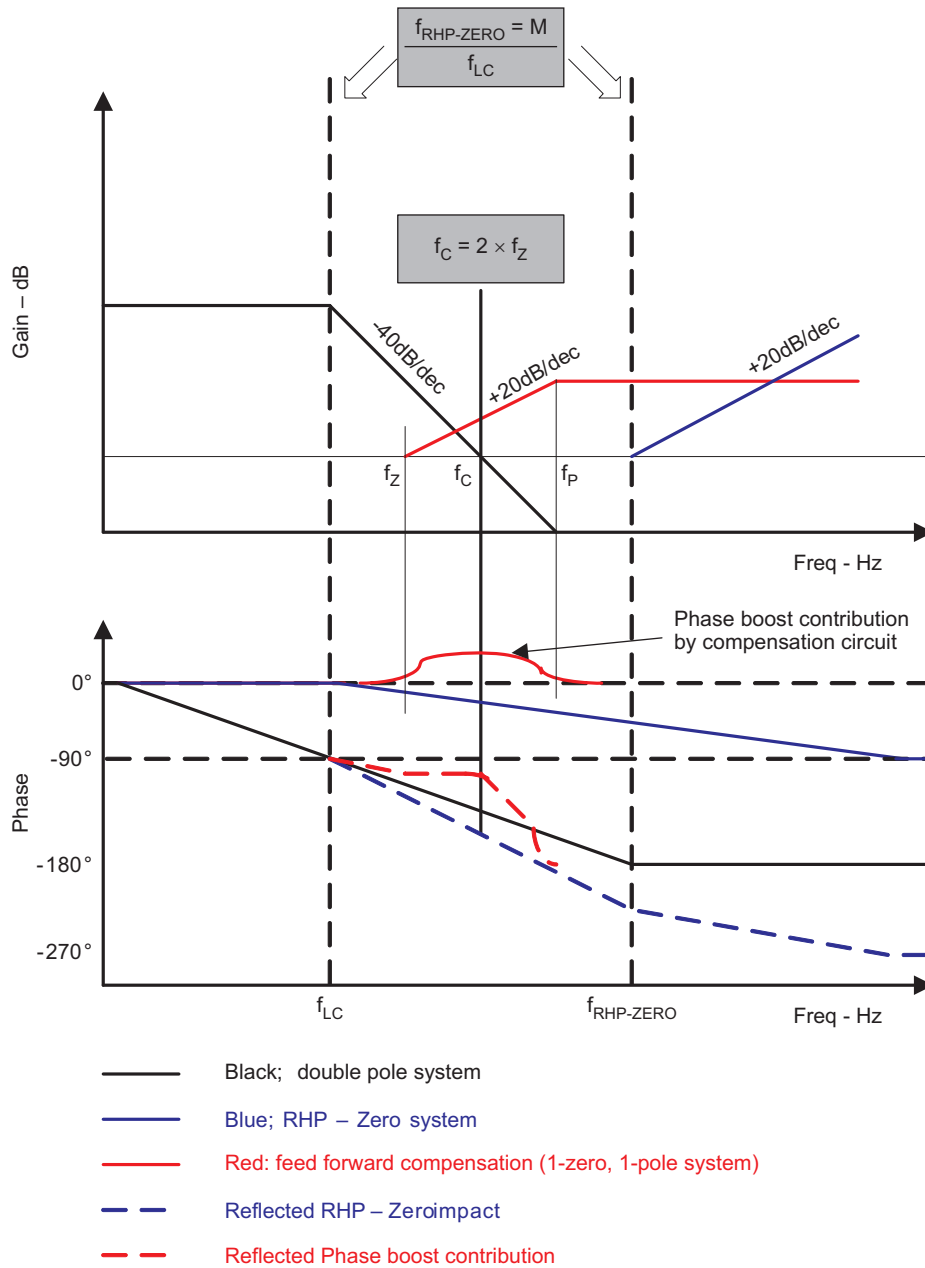

G010

Figure 10. Stability Criteria

Figure 10 is an illustration of stability criteria and is used to ensure converter performance based on the type of loop compensation implemented.

8 Application and Implementation

NOTE

Information in the following applications sections is not part of the TI component specification, and TI does not warrant its accuracy or completeness. TI's customers are responsible for determining suitability of components for their purposes. Customers should validate and test their design implementation to confirm system functionality.

8.1 Application Information

The TPS55332-Q1 device can function as a switch mode boost converter along with voltage supervisor. The system can function at input voltage as low as 1.5 V once the internal circuits have stabilized. The supervisor circuit monitors the regulated output and indicates when the output voltage has fallen below the set value. The variable switching frequency allows use of low profile inductors and low value input and output capacitors.

8.2 Typical Application

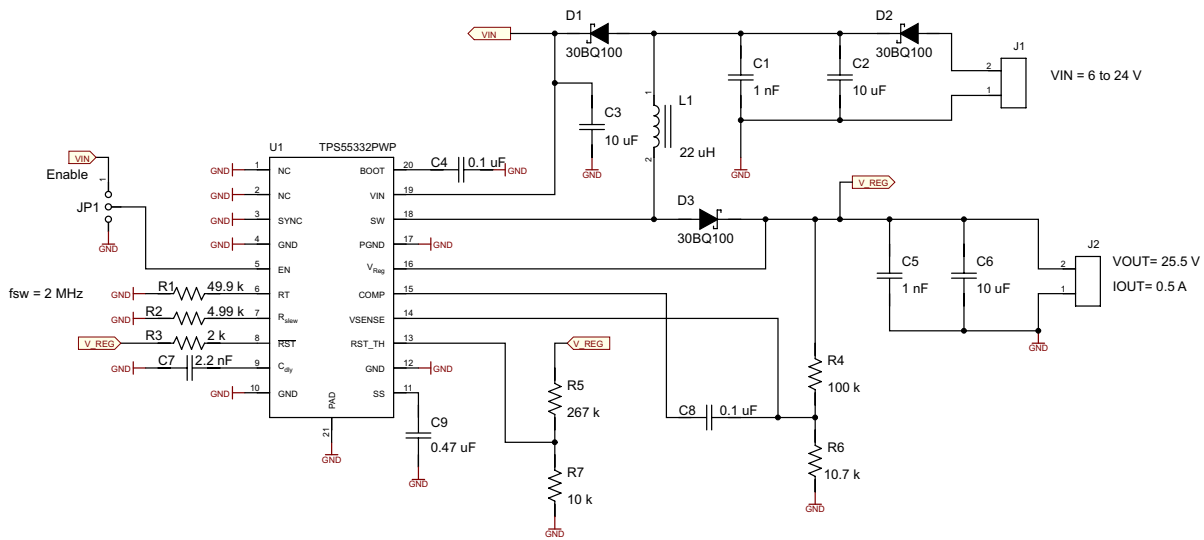

S001

Figure 11. Typical Application Schematic

8.2.1 Design Requirements

Table 1 table lists the requirements of a switching regulator design.

Table 1. Design Parameters

PARAMETER	VALUE
Input voltage, V_{IN}	6 V to 24 V, with typical operating voltage = 14 V
Output voltage, V	25.5 V \pm 2%
Maximum output current, I_O	0.5 A
Transient response 0A to 0.3 A	5%
Switching frequency, f_{sw}	2 MHz
Reset threshold	84% of output voltage
V_O _ripple	520 mV peak to peak at capacitance
V_O _transient	92% of output voltage

8.2.2 Detailed Design Procedure

The design considers the converter to operate in CCM for most of the operating range and in DCM during less than 10% of the maximum load rating. CCM mode has an RHP of zero. Thus, compensation becomes critical under CCM mode. Operating the converter in DCM mode results in higher switch and inductor currents and thereby higher losses. In this design example, we focus on circuit operating mostly under CCM mode.

8.2.2.1 Output Capacitor (Co)

Selection of the output capacitor in CCM using [Equation 19](#) gives a capacitor value of 0.37 μF .

Output ripple voltage is a product of output capacitor ESR and ripple current on the output capacitor Co.

The minimum output capacitor required for a desired output ripple voltage is given by:

$$V_{O_{\text{ripple ESR}}} = I_O \times \text{ESR} \quad (\text{Volts}) \quad (24)$$

$$C_{(\text{min ripple})} = \frac{I_O}{V_{O_{\text{ripple cap}}}} \left(1 - \frac{V_{\text{IN}}}{V_O} \right) \frac{1}{f_{\text{sw}}} \quad (25)$$

The minimum capacitance needed for the output voltage ripple specification, using [Equation 19](#), $C_{\downarrow(\text{min } \downarrow \text{ripple})} = 0.37 \mu\text{F}$.

Using [Equation 20](#), the transient response should be taken into consideration when selecting the output capacitor. The minimum capacitance required for a duration dt with a load transient I_{tran} to allow a maximum output voltage droop of $V_{O_{\text{droop}}}$ is:

$$C_{(\text{min tran})} = \frac{I_{\text{tran}} dt}{V_{O_{\text{droop}}}} = \frac{I_{\text{tran}}}{V_{O_{\text{droop}}}} \times \frac{1}{4 \times f_c} \quad (\text{Farads}) \quad (26)$$

Where,

dt is approximated to $1 / 4 \times f_c$ ($f_c = 10 \text{ kHz}$ bandwidth)

This gives a capacitance of 7.35 μF . Allowing for tolerances and temperature variations, use a 10 μF standard value output capacitor.

8.2.2.2 Output Inductor Selection (Lo) for CCM

Using [Equation 21](#), the minimum lead current for ccm operation is 10% of maximum output current, $I_{O\text{-DCM}} = 50 \text{ mA}$. The inductor value is selected as $L = 22 \mu\text{H}$.

8.2.2.3 Output Diode

The TPS55332 requires an external output diode which conducts when the power switch is turned off. This provides the path for the inductor current to the output capacitor. The important factors in selecting the rectifier are: fast switching, reverse breakdown voltage, current rating, and forward-voltage drop. The breakdown voltage should be greater than the maximum output voltage; the current rating must be two times the maximum switch output current. The forward drop of the diode should be low (schottky rectifier is preferred). The schottky diode is selected based on the appropriate power rating, which factors in the dc conduction losses; this is determined by [Equation 27](#):

$$P_{\text{diode}} = V_{fd} \times I_O \times (1 - D) \quad (\text{Watts}) \quad (27)$$

Where,

V_{fd} = forward conducting voltage of Schottky diode

8.2.2.4 Input Capacitor Ci

The TPS55332 requires an input ceramic de-coupling capacitor type X5R or X7R and bulk capacitance to minimize input ripple voltage. The dc voltage rating of this input capacitance must be greater than the maximum input voltage. The capacitor must have an input ripple current rating higher than the maximum input ripple current of the converter for the application; this is determined by [Equation 28](#).

The input capacitors for power regulators are chosen to have a reasonable capacitance to volume ratio and be fairly stable over the temperature range.

$$I_{L-RMS} = I_O \times \sqrt{\frac{(V_O)}{(V_{L-min})} \times \frac{(V_{L-min} - V_O)}{V_{L-min}}} \quad (\text{Amperes}) \quad (28)$$

8.2.2.5 Output Voltage And Feedback Resistor Selection

In the design example, 100 kΩ was selected for R4, using [Equation 1](#), R6 is calculated as 10.7 kΩ. Higher resistor values help improve converter efficiency at low output currents but may introduce noise immunity problems.

8.2.2.6 Reset Threshold Resistor Selection

Using [Equation 6](#), select resistor R7 as 10 kΩ then calculate R5. This gives a resistor value of 263 kΩ; use a standard value of 267 kΩ. This sets the reset threshold at $0.86 \times 25.5 \text{ V}$.

8.2.2.7 Soft Start Capacitor

The soft start capacitor determines the minimum time to reach the desired output voltage during a power up cycle. This is useful when a load requires a controlled voltage slew rate and helps to limit the current draw from the input voltage supply line. [Equation 4](#) and [Equation 5](#) have to be satisfied in addition to the other conditions stated in the soft start section of this document. In this design a 47-nF capacitor is required to meet these criteria.

8.2.2.8 Loop Compensation Calculation

To make sure the right hand plane zero does not impact converter design in CCM operation based on $V_{IN} = 6 \text{ V}$, $L = 22 \mu\text{H}$, and $C_o = 10 \mu\text{f}$, calculated values using [Equation 16](#), the frequency is set at:

$$f_{RHP} = 20.436 \text{ kHz}$$

The double pole associated with the L and C_o components is given by [Equation 15](#):

$$f_{LC} = 2.526 \text{ kHz}$$

Using [Equation 14](#):

$$f_C = 6.744 \text{ kHz}$$

The zero due to the ESR of the capacitor is beyond the right hand plane zero frequency and can be calculated based on [Equation 17](#) and [Equation 23](#).

So to avoid any instability issues and from the frequency values calculated above the amplifier gain requires a gain roll off much earlier than the double pole of the L and C_o components.

So the pole must be set at a much lower frequency to obtain a reasonable phase margin.

Using [Equation 18](#) and choosing a frequency close to 2.9 Hz for the pole frequency, the capacitor value C8 for this application is:

$$C8 = 0.54 \mu\text{F}$$

If C8 = 0.1 μF standard value, then $f_P = 15.9 \text{ Hz}$.

8.2.2.9 Loop Compensation Response

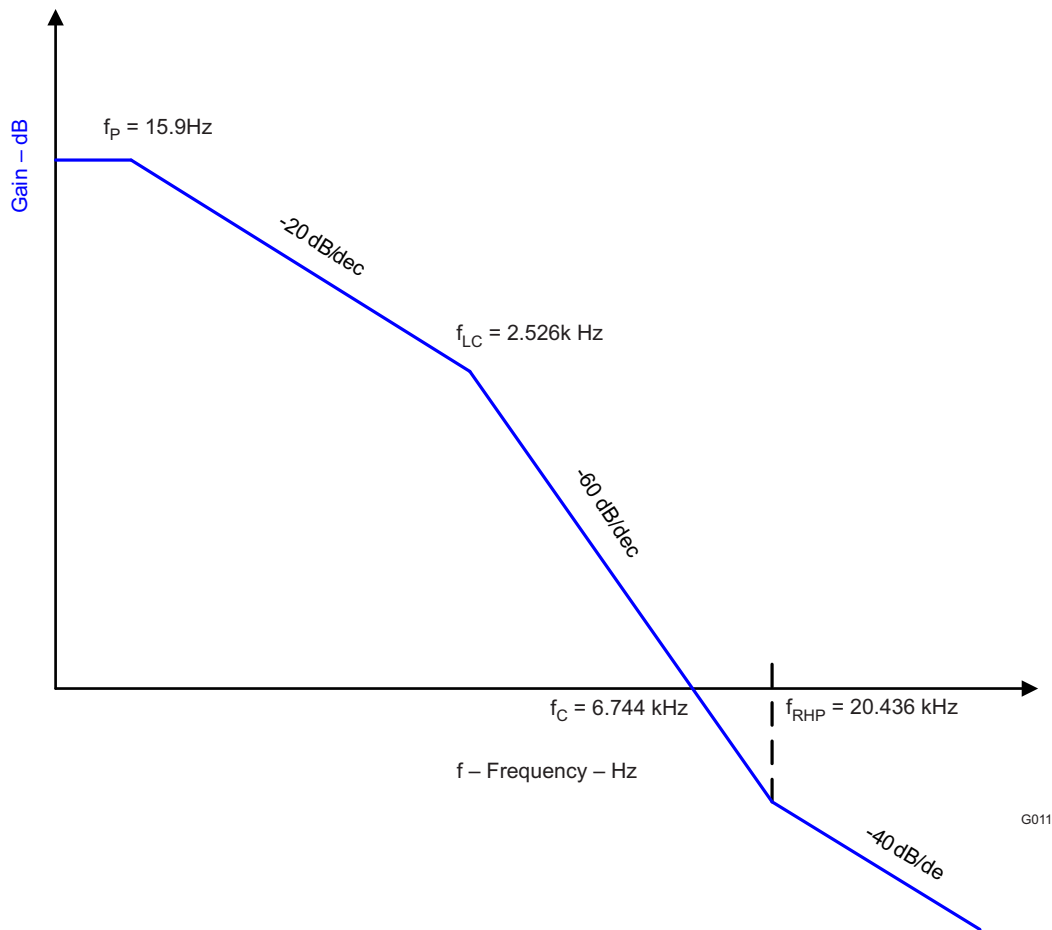

Figure 12. Loop Compensation Response

Since the pole due to the integrating capacitor C4 is dominant in the compensation loop, the frequency of the pole due to the inductor has no consequence in this situation.

8.2.2.10 Output Inductor Selection (LO) For DCM

The maximum inductor value is calculated using [Equation 16](#) and gives a value of $0.532 \mu\text{H}$. This allows the converter to be in DCM mode over the full operating range.

To operate in this mode with the calculated inductor value, the right hand plane zero frequency has moved to 846 kHz and the cut off frequency is 279.1 kHz .

The double pole due to the L and Co values is 16.25 kHz .

To compensate with either type II or type III loop compensation, the Bode Plot stability criteria must be satisfied.

[Figure 14](#) shows the Efficiency readings for TPS55332 running mostly in DCM mode. When the switching frequency is reduced from 2 MHz to 180 kHz , keeping the Inductance and output load fixed, the converter sees higher peak currents in the switch and inductor. Higher currents lead to losses and thus efficiency readings come out to be lower than when the converter runs in CCM mode.

8.2.3 Application Curves

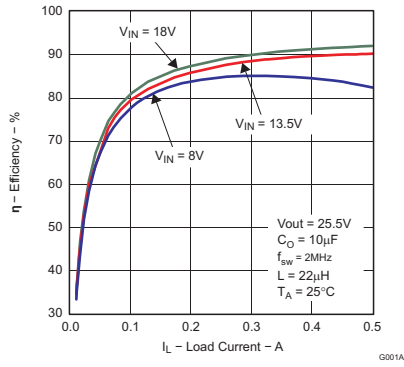

Figure 13. Efficiency (%) vs Load Current (A)

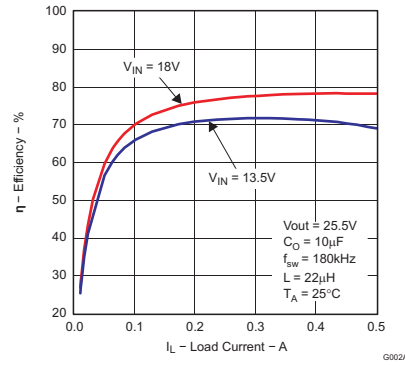

Figure 14. Efficiency (%) vs Load Current (A)

9 Power Supply Recommendations

The TPS55332-Q1 device is designed to operate from an input voltage up to 40 V. Ensure that the input supply is well regulated. Furthermore, if the supply voltage in the application is likely to reach negative voltage (for example, reverse battery) a forward diode must be placed at the input of the supply. For the VIN pin, a small ceramic capacitor with a typical value of 0.1 μ F is recommended. Capacitance de-rating for aging, temperature, and DC bias must be taken into account while determining the capacitor value. Connect a local decoupling capacitor close to the BOOT pin for proper gate drive voltage for the internal MOSFET switch.

10 Layout

10.1 Layout Guidelines

The recommended guidelines for PCB layout of the TPS55332 device are described in the following sections.

10.1.1 Inductor

Use a low EMI inductor with a ferrite type shielded core. Other types of inductors may be used, however they must have low EMI characteristics and be located away from the low power traces and components in the circuit.

10.1.2 Input Filter Capacitors

Input ceramic filter capacitors should be located in close proximity of the VIN terminal. Surface mount capacitors are recommended to minimize lead length and reduce noise coupling. Also low ESR and max input ripple current requirements must be satisfied.

10.1.3 Feedback

Route the feedback trace such that there is minimum interaction with any noise sources associated with the switching components. Recommended practice is to ensure the inductor is placed away from the feedback trace to prevent EMI noise sourcing.

10.1.4 Traces And Ground Plane

All power (high current) traces should be as thick and short as possible. The inductor and output capacitors should be as close to each other as possible. This reduces EMI radiated by the power traces due to high switching currents.

In a two sided PCB it is recommended to have ground planes on both sides of the PCB to help reduce noise and ground loop errors. The ground connection for the input and output capacitors and IC ground should be connected to this ground plane.

In a multi-layer PCB, the ground plane is used to separate the power plane (high switching currents and components are placed) from the signal plane (where the feedback trace and components are placed) for improved performance.

Also arrange the components such that the switching current loops curl in the same direction. Place the high current components such that during conduction the current path is in the same direction. This prevents magnetic field reversal caused by the traces between the two half cycles, helping to reduce radiated EMI.

The power ground terminal for the power FET must also be terminated to the ground plane in the shortest trace possible.

10.2 Layout Example

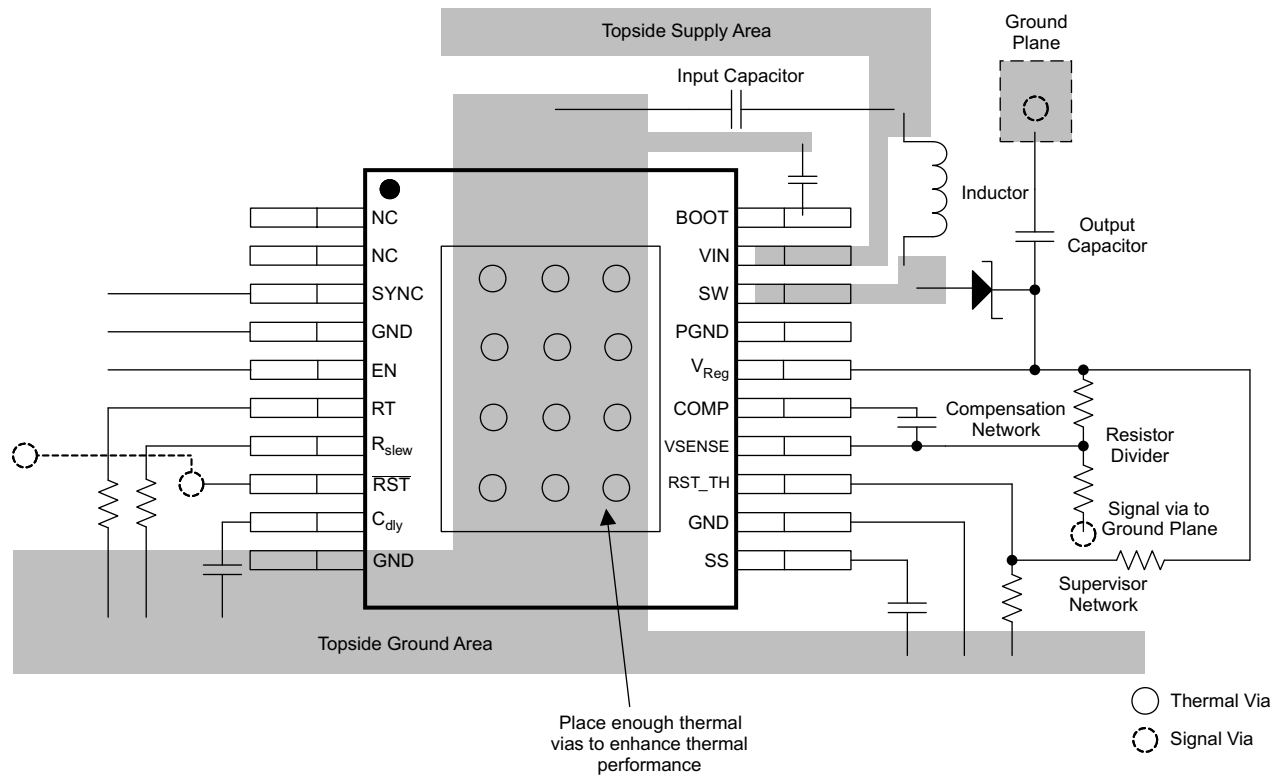

M0148-01

Figure 15. PCB Layout Example

Layout Example (continued)

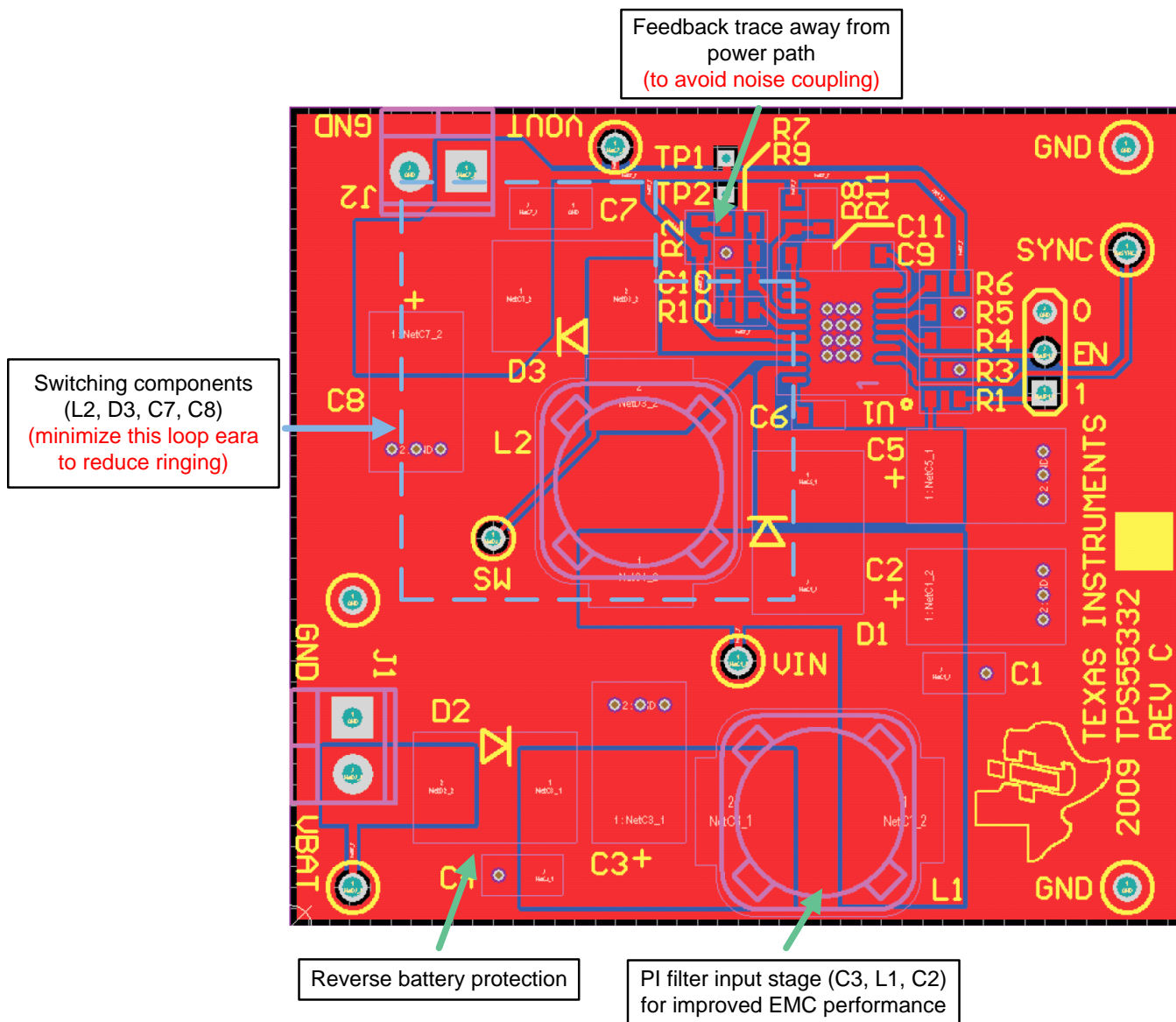
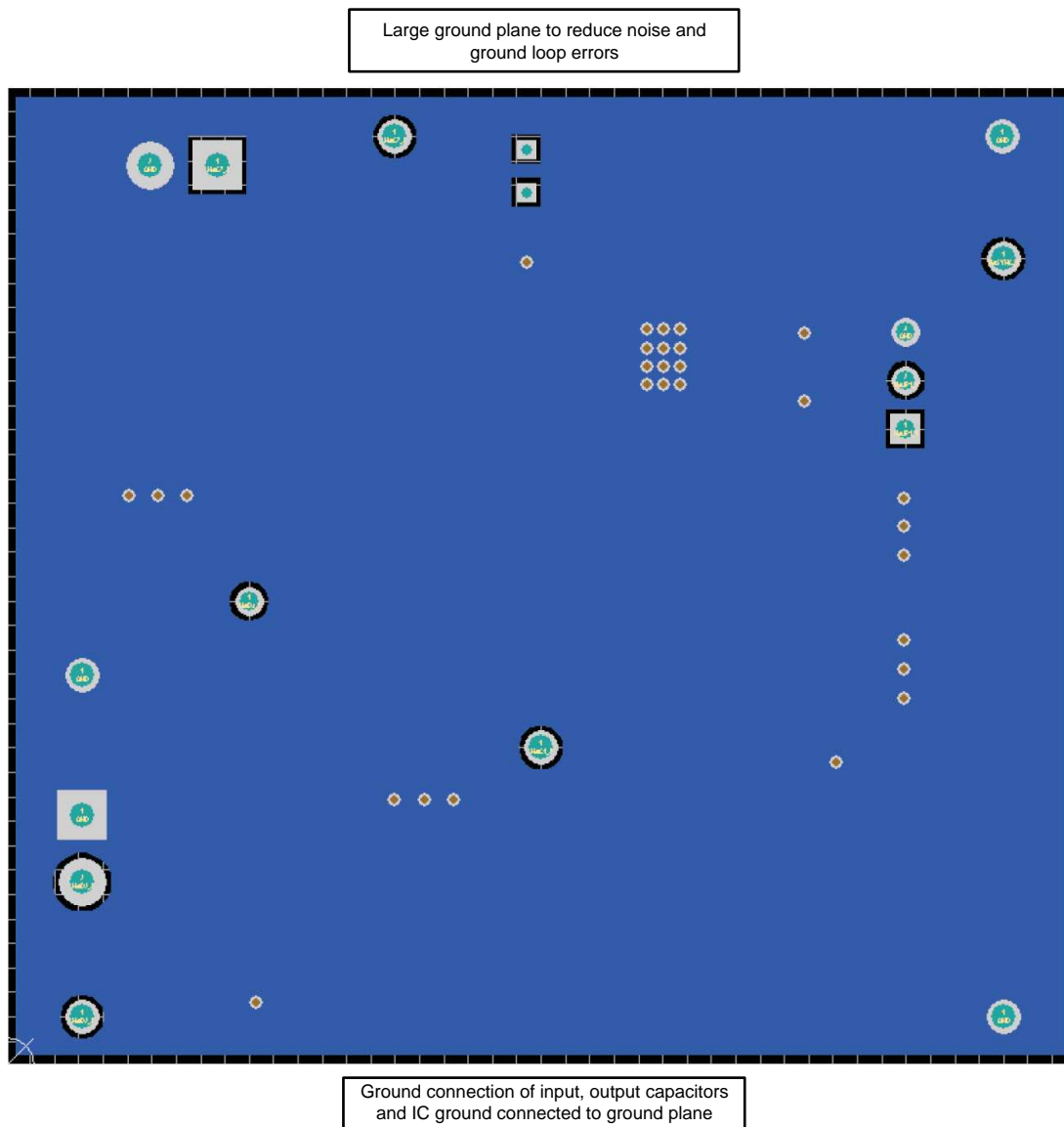

Figure 16. Top Layer

Layout Example (continued)

Figure 17. Bottom Layer
10.3 Power Dissipation

The power dissipation losses are applicable for continuous conduction mode operation (CCM).

$$P_{CON} = I_o^2 \times R_{dsON} \times (1 - V_i/V_o) \quad (\text{conduction losses}) \quad (29)$$

$$P_{SW} = \frac{1}{2} \times V_o \times I_o / (1 - D) \times (t_r + t_f) \times f_{SW} \quad (\text{switching losses}) \quad (30)$$

$$P_{Gate} = V_{drive} \times Q_g \times f_{sw} \quad (\text{gate drive losses}), \text{ where } Q_g = 1 \times 10^{-9} \text{ (nC)} \quad (31)$$

$$P_{IC} = V_i \times I_q\text{-normal} \quad (\text{supply losses}) \quad (32)$$

$$P_{Total} = P_{CON} + P_{SW} + P_{Gate} + P_{IC} \quad (\text{watts}) \quad (33)$$

Where:

V_o = Output voltage

V_i = Input voltage

I_o = Output current

t_r = FET switching rise time ($t_r \text{ max} = 40 \text{ ns}$)

Power Dissipation (continued)

- tf = FET switching fall time
- V_{drive} = FET gate drive voltage (typically V_{drive} = 6 V and V_{drive max} = 8 V)
- f_{sw} = Switching frequency
- D = Duty cycle

For given operating ambient temperature, T_{Amb}:

$$T_J = T_{Amb} + R_{th} \times P_{Total} \tag{34}$$

For a given max junction temperature of T_{J-Max} = 150°C:

$$T_{Amb-Max} = T_{J-Max} - R_{th} \times P_{Total} \tag{35}$$

Where:

- P_{Total} = Total power dissipation (watts)
- T_{Amb} = Ambient temperature in °C
- T_J = Junction temperature in °C
- T_{Amb-Max} = Maximum ambient temperature in °C
- T_{J-Max} = Maximum junction temperature in °C
- R_{th} = Thermal resistance of package in (°C/W)

Other factors NOT included in the information above which affect the overall efficiency and power losses are inductor ac and dc losses, and trace resistance and losses associated with the copper trace routing connection.

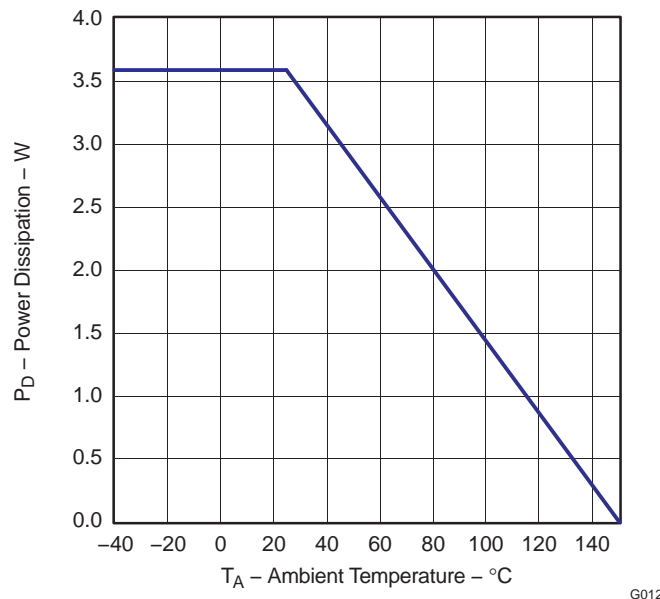

NOTE: Power de-rating based on JEDEC JESD 51-5 standard board with thermal vias and high-k profile.

Figure 18. Power Dissipation

11 Device and Documentation Support

11.1 Trademarks

PowerPAD is a trademark of Texas Instruments.
All other trademarks are the property of their respective owners.

11.2 Electrostatic Discharge Caution



These devices have limited built-in ESD protection. The leads should be shorted together or the device placed in conductive foam during storage or handling to prevent electrostatic damage to the MOS gates.

11.3 Glossary

[SLYZ022](#) — *TI Glossary*.

This glossary lists and explains terms, acronyms, and definitions.

12 Mechanical, Packaging, and Orderable Information

The following pages include mechanical, packaging, and orderable information. This information is the most current data available for the designated devices. This data is subject to change without notice and revision of this document. For browser-based versions of this data sheet, refer to the left-hand navigation.

PACKAGING INFORMATION

Orderable Device	Status (1)	Package Type	Package Drawing	Pins	Package Qty	Eco Plan (2)	Lead/Ball Finish (6)	MSL Peak Temp (3)	Op Temp (°C)	Device Marking (4/5)	Samples
TPS55332QPWRQ1	ACTIVE	HTSSOP	PWP	20	2000	Green (RoHS & no Sb/Br)	CU NIPDAU	Level-3-260C-168 HR	-40 to 125	55332Q1	Samples

(1) The marketing status values are defined as follows:

ACTIVE: Product device recommended for new designs.

LIFEBUY: TI has announced that the device will be discontinued, and a lifetime-buy period is in effect.

NRND: Not recommended for new designs. Device is in production to support existing customers, but TI does not recommend using this part in a new design.

PREVIEW: Device has been announced but is not in production. Samples may or may not be available.

OBSELETE: TI has discontinued the production of the device.

(2) Eco Plan - The planned eco-friendly classification: Pb-Free (RoHS), Pb-Free (RoHS Exempt), or Green (RoHS & no Sb/Br) - please check <http://www.ti.com/productcontent> for the latest availability information and additional product content details.

TBD: The Pb-Free/Green conversion plan has not been defined.

Pb-Free (RoHS): TI's terms "Lead-Free" or "Pb-Free" mean semiconductor products that are compatible with the current RoHS requirements for all 6 substances, including the requirement that lead not exceed 0.1% by weight in homogeneous materials. Where designed to be soldered at high temperatures, TI Pb-Free products are suitable for use in specified lead-free processes.

Pb-Free (RoHS Exempt): This component has a RoHS exemption for either 1) lead-based flip-chip solder bumps used between the die and package, or 2) lead-based die adhesive used between the die and leadframe. The component is otherwise considered Pb-Free (RoHS compatible) as defined above.

Green (RoHS & no Sb/Br): TI defines "Green" to mean Pb-Free (RoHS compatible), and free of Bromine (Br) and Antimony (Sb) based flame retardants (Br or Sb do not exceed 0.1% by weight in homogeneous material)

(3) MSL, Peak Temp. - The Moisture Sensitivity Level rating according to the JEDEC industry standard classifications, and peak solder temperature.

(4) There may be additional marking, which relates to the logo, the lot trace code information, or the environmental category on the device.

(5) Multiple Device Markings will be inside parentheses. Only one Device Marking contained in parentheses and separated by a "~" will appear on a device. If a line is indented then it is a continuation of the previous line and the two combined represent the entire Device Marking for that device.

(6) Lead/Ball Finish - Orderable Devices may have multiple material finish options. Finish options are separated by a vertical ruled line. Lead/Ball Finish values may wrap to two lines if the finish value exceeds the maximum column width.

Important Information and Disclaimer: The information provided on this page represents TI's knowledge and belief as of the date that it is provided. TI bases its knowledge and belief on information provided by third parties, and makes no representation or warranty as to the accuracy of such information. Efforts are underway to better integrate information from third parties. TI has taken and continues to take reasonable steps to provide representative and accurate information but may not have conducted destructive testing or chemical analysis on incoming materials and chemicals. TI and TI suppliers consider certain information to be proprietary, and thus CAS numbers and other limited information may not be available for release.

In no event shall TI's liability arising out of such information exceed the total purchase price of the TI part(s) at issue in this document sold by TI to Customer on an annual basis.

TAPE AND REEL INFORMATION

QUADRANT ASSIGNMENTS FOR PIN 1 ORIENTATION IN TAPE

*All dimensions are nominal

Device	Package Type	Package Drawing	Pins	SPQ	Reel Diameter (mm)	Reel Width W1 (mm)	A0 (mm)	B0 (mm)	K0 (mm)	P1 (mm)	W (mm)	Pin1 Quadrant
TPS55332QPWPRQ1	HTSSOP	PWP	20	2000	330.0	16.4	6.95	7.1	1.6	8.0	16.0	Q1

TAPE AND REEL BOX DIMENSIONS



*All dimensions are nominal

Device	Package Type	Package Drawing	Pins	SPQ	Length (mm)	Width (mm)	Height (mm)
TPS55332QPWPRQ1	HTSSOP	PWP	20	2000	367.0	367.0	38.0

MECHANICAL DATA

PWP (R-PDSO-G20)

PowerPAD™ PLASTIC SMALL OUTLINE

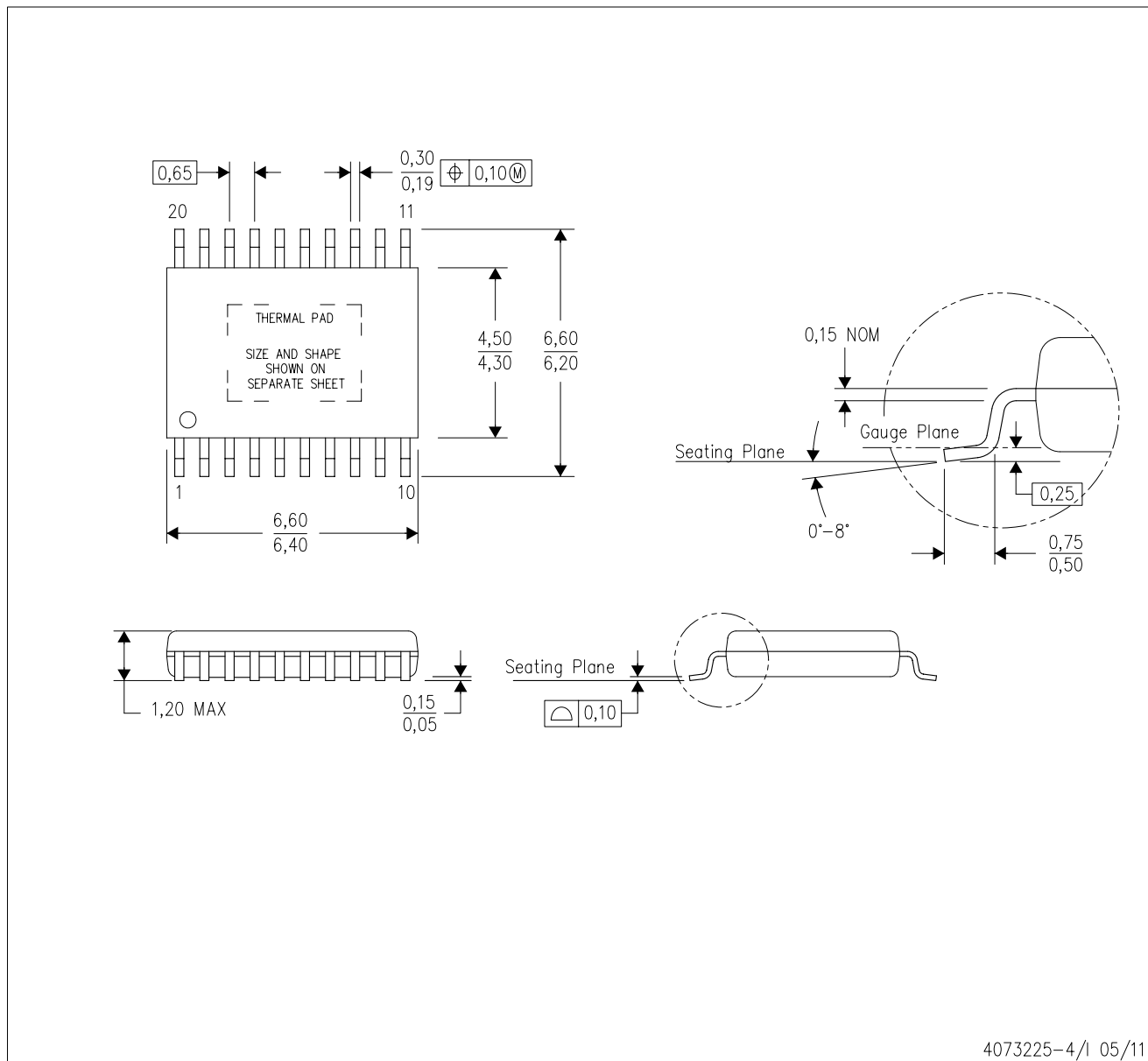

4073225-4/1 05/11

- NOTES:
- All linear dimensions are in millimeters.
 - This drawing is subject to change without notice.
 - Body dimensions do not include mold flash or protrusions. Mold flash and protrusion shall not exceed 0.15 per side.
 - This package is designed to be soldered to a thermal pad on the board. Refer to Technical Brief, PowerPad Thermally Enhanced Package, Texas Instruments Literature No. SLMA002 for information regarding recommended board layout. This document is available at www.ti.com <<http://www.ti.com>>.
 - See the additional figure in the Product Data Sheet for details regarding the exposed thermal pad features and dimensions.
 - Falls within JEDEC MO-153

PowerPAD is a trademark of Texas Instruments.

THERMAL PAD MECHANICAL DATA

PWP (R-PDSO-G20) PowerPAD™ SMALL PLASTIC OUTLINE

THERMAL INFORMATION

This PowerPAD™ package incorporates an exposed thermal pad that is designed to be attached to a printed circuit board (PCB). The thermal pad must be soldered directly to the PCB. After soldering, the PCB can be used as a heatsink. In addition, through the use of thermal vias, the thermal pad can be attached directly to the appropriate copper plane shown in the electrical schematic for the device, or alternatively, can be attached to a special heatsink structure designed into the PCB. This design optimizes the heat transfer from the integrated circuit (IC).

For additional information on the PowerPAD package and how to take advantage of its heat dissipating abilities, refer to Technical Brief, PowerPAD Thermally Enhanced Package, Texas Instruments Literature No. SLMA002 and Application Brief, PowerPAD Made Easy, Texas Instruments Literature No. SLMA004. Both documents are available at www.ti.com.

The exposed thermal pad dimensions for this package are shown in the following illustration.

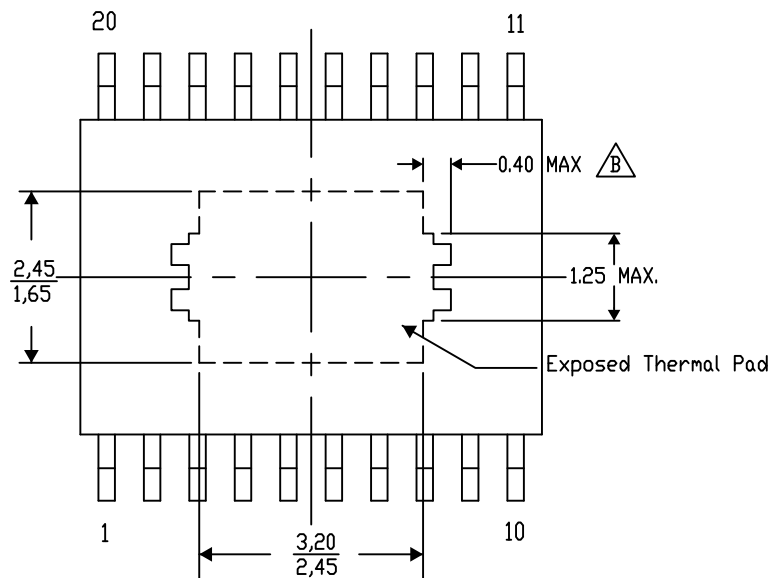

4206332-18/AJ 10/14

NOTE: A. All linear dimensions are in millimeters

 Exposed tie strap features may not be present.

PowerPAD is a trademark of Texas Instruments

PWP (R-PDSO-G20)

PowerPAD™ PLASTIC SMALL OUTLINE

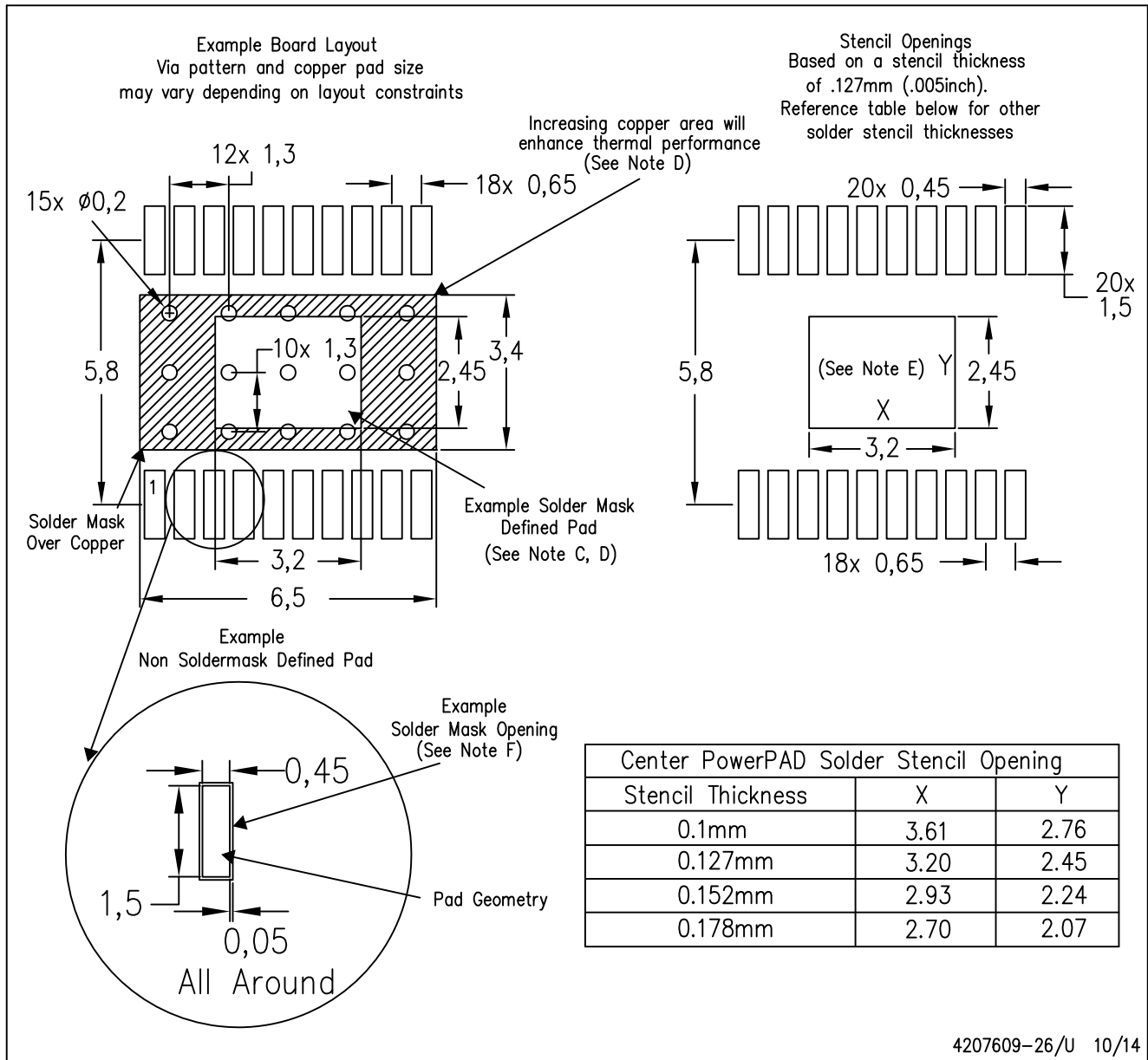

- NOTES:
- All linear dimensions are in millimeters.
 - This drawing is subject to change without notice.
 - Customers should place a note on the circuit board fabrication drawing not to alter the center solder mask defined pad.
 - This package is designed to be soldered to a thermal pad on the board. Refer to Technical Brief, PowerPad Thermally Enhanced Package, Texas Instruments Literature No. SLMA002, SLMA004, and also the Product Data Sheets for specific thermal information, via requirements, and recommended board layout. These documents are available at www.ti.com <<http://www.ti.com>>. Publication IPC-7351 is recommended for alternate designs.
 - Laser cutting apertures with trapezoidal walls and also rounding corners will offer better paste release. Customers should contact their board assembly site for stencil design recommendations. Example stencil design based on a 50% volumetric metal load solder paste. Refer to IPC-7525 for other stencil recommendations.
 - Customers should contact their board fabrication site for solder mask tolerances between and around signal pads.

IMPORTANT NOTICE

Texas Instruments Incorporated and its subsidiaries (TI) reserve the right to make corrections, enhancements, improvements and other changes to its semiconductor products and services per JESD46, latest issue, and to discontinue any product or service per JESD48, latest issue. Buyers should obtain the latest relevant information before placing orders and should verify that such information is current and complete. All semiconductor products (also referred to herein as "components") are sold subject to TI's terms and conditions of sale supplied at the time of order acknowledgment.

TI warrants performance of its components to the specifications applicable at the time of sale, in accordance with the warranty in TI's terms and conditions of sale of semiconductor products. Testing and other quality control techniques are used to the extent TI deems necessary to support this warranty. Except where mandated by applicable law, testing of all parameters of each component is not necessarily performed.

TI assumes no liability for applications assistance or the design of Buyers' products. Buyers are responsible for their products and applications using TI components. To minimize the risks associated with Buyers' products and applications, Buyers should provide adequate design and operating safeguards.

TI does not warrant or represent that any license, either express or implied, is granted under any patent right, copyright, mask work right, or other intellectual property right relating to any combination, machine, or process in which TI components or services are used. Information published by TI regarding third-party products or services does not constitute a license to use such products or services or a warranty or endorsement thereof. Use of such information may require a license from a third party under the patents or other intellectual property of the third party, or a license from TI under the patents or other intellectual property of TI.

Reproduction of significant portions of TI information in TI data books or data sheets is permissible only if reproduction is without alteration and is accompanied by all associated warranties, conditions, limitations, and notices. TI is not responsible or liable for such altered documentation. Information of third parties may be subject to additional restrictions.

Resale of TI components or services with statements different from or beyond the parameters stated by TI for that component or service voids all express and any implied warranties for the associated TI component or service and is an unfair and deceptive business practice. TI is not responsible or liable for any such statements.

Buyer acknowledges and agrees that it is solely responsible for compliance with all legal, regulatory and safety-related requirements concerning its products, and any use of TI components in its applications, notwithstanding any applications-related information or support that may be provided by TI. Buyer represents and agrees that it has all the necessary expertise to create and implement safeguards which anticipate dangerous consequences of failures, monitor failures and their consequences, lessen the likelihood of failures that might cause harm and take appropriate remedial actions. Buyer will fully indemnify TI and its representatives against any damages arising out of the use of any TI components in safety-critical applications.

In some cases, TI components may be promoted specifically to facilitate safety-related applications. With such components, TI's goal is to help enable customers to design and create their own end-product solutions that meet applicable functional safety standards and requirements. Nonetheless, such components are subject to these terms.

No TI components are authorized for use in FDA Class III (or similar life-critical medical equipment) unless authorized officers of the parties have executed a special agreement specifically governing such use.

Only those TI components which TI has specifically designated as military grade or "enhanced plastic" are designed and intended for use in military/aerospace applications or environments. Buyer acknowledges and agrees that any military or aerospace use of TI components which have **not** been so designated is solely at the Buyer's risk, and that Buyer is solely responsible for compliance with all legal and regulatory requirements in connection with such use.

TI has specifically designated certain components as meeting ISO/TS16949 requirements, mainly for automotive use. In any case of use of non-designated products, TI will not be responsible for any failure to meet ISO/TS16949.

Products

Audio	www.ti.com/audio
Amplifiers	amplifier.ti.com
Data Converters	dataconverter.ti.com
DLP® Products	www.dlp.com
DSP	dsp.ti.com
Clocks and Timers	www.ti.com/clocks
Interface	interface.ti.com
Logic	logic.ti.com
Power Mgmt	power.ti.com
Microcontrollers	microcontroller.ti.com
RFID	www.ti-rfid.com
OMAP Applications Processors	www.ti.com/omap
Wireless Connectivity	www.ti.com/wirelessconnectivity

Applications

Automotive and Transportation	www.ti.com/automotive
Communications and Telecom	www.ti.com/communications
Computers and Peripherals	www.ti.com/computers
Consumer Electronics	www.ti.com/consumer-apps
Energy and Lighting	www.ti.com/energy
Industrial	www.ti.com/industrial
Medical	www.ti.com/medical
Security	www.ti.com/security
Space, Avionics and Defense	www.ti.com/space-avionics-defense
Video and Imaging	www.ti.com/video

TI E2E Community

e2e.ti.com