

- Enclosed power supply with screw terminal connection
- Certification according to IEC/EN/ES 60601-1 3rd edition for 2 x MOPP
- Low leakage current <75 µA rated for BF applications
- Risk management process according to ISO 14971 incl. risk management file
- Acceptance criteria for electronic assemblies acc. to IPC-A-610 Level 3
- EMC compliance to IEC 60601-1-2 ed. 4
- Protection class I and II
- Operating up to 5000 m altitude
- Ready to meet ErP directive, <0.15 W no load power consumption
- 5-year product warranty

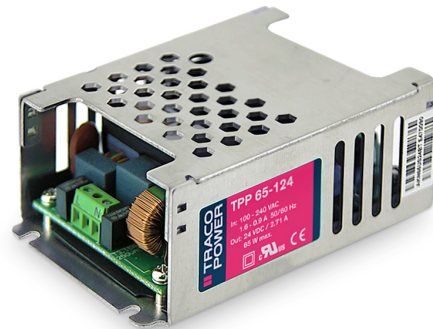

The TPP 65 Series of 65 Watt AC/DC power supplies feature a reinforced double I/O isolation system according to latest medical safety standards (60601-1 3rd edition, 2 x MOPP). The earth leakage current is below 75 µA what makes the units suitable for BF (body floating) applications.

The excellent efficiency of up to 92% allows a high power density for the standard 2.44" x 3.0" packaging format. The full load operating temperature range is -40°C to +60°C while it goes up to 85°C with 50% load derating (for single output models). The EMC characteristic is dedicated for applications in industrial and domestic fields.

High reliability is provided by use of industrial quality grade components and an excellent thermal management. It makes the products an ideal solution for medical devices and for demanding safety and space critical applications.

Models

Order Code	Output Power	Output 1		Output 2		Output 3		Efficiency typ.
		Vnom	I _{max}	Vnom	I _{max}	Vnom	I _{max}	
TPP 65-105	50 W	5 VDC	10'000 mA					90 %
TPP 65-112		12 VDC	5'420 mA					93 %
TPP 65-115		15 VDC	4'340 mA					94 %
TPP 65-124		24 VDC	2'710 mA					94 %
TPP 65-221		+12 VDC	5'420 mA	+5 VDC	8'000 mA			90 %
TPP 65-231		+15 VDC	4'340 mA	+5 VDC	8'000 mA			91 %
TPP 65-251		+24 VDC	2'710 mA	+5 VDC	8'000 mA			89 %
TPP 65-321M2		+12 VDC	5'420 mA	+5 VDC	8'000 mA	-12 VDC	600 mA	89 %
TPP 65-331M3		+15 VDC	4'340 mA	+5 VDC	8'000 mA	-15 VDC	600 mA	90 %
TPP 65-3512	+24 VDC	2'710 mA	+5 VDC	8'000 mA	+12 VDC	600 mA	89 %	

- Note
- Total Power must not exceed 65 W.
 - Other output models are available on request.
 - Multi output models have a common ground.

Input Specifications

Input Voltage	- AC Range - DC Range	85 - 264 VAC (Full Range) 120 - 370 VDC (Designed for, no certification) (DC+: N / DC-: L)
Input Frequency		47 - 63 Hz
Input Current	- Full Load & Vin = 230 VAC - Full Load & Vin = 115 VAC	950 mA max. 1'650 mA max.
Power Consumption	- At no load	150 mW max. (Ready to meet ErP directive)
Input Inrush Current	- At 230 VAC	60 A max.
Input Protection		T 3.15 A / 250 VAC (Internal Fuse in L & N)
Recommended Input Fuse		(The need of an external fuse has to be assessed in the final application.)

Output Specifications

Output Voltage Adjustment		±10% (only Output 1) (By trim potentiometer) Output power must not exceed rated power!
Voltage Set Accuracy		±1% max. (Output 1) ±2% max. (Output 2 and 3)
Regulation	- Input Variation (Vmin - Vmax) - Load Variation (0 - 100%) - Cross Regulation (25% / 100% asym. load)	single output models: 0.2% max. dual output models: 0.2% max. triple output models: 0.2% max. single output models: 0.7% max. (5 VDC model) 0.5% max. (other output models) dual output models: 0.5% max. (Output 1) 1.5% max. (Output 2) triple output models: 0.5% max. (Output 1) 1.5% max. (Output 2) 0.7% max. (Output 3) dual output models: 1.5% max. triple output models: 1.5% max.
Ripple and Noise (20 MHz Bandwidth)	- single output - dual output - triple output	5 VDC model: 75 mVp-p typ. (w/ 10 µF X7R) 12 VDC model: 75 mVp-p typ. (w/ 10 µF X7R) 15 VDC model: 75 mVp-p typ. (w/ 10 µF X7R) 24 VDC model: 75 mVp-p typ. (w/ 1 µF X7R) 12 / 5 VDC model: 120 / 100 mVp-p typ. (w/ 10 µF X7R) 15 / 5 VDC model: 150 / 100 mVp-p typ. (w/ 10 µF X7R) 24 / 5 VDC model: 240 / 100 mVp-p typ. (w/ 10 µF X7R) 12 / 5 / -12 VDC model: 120 / 100 / 120 mVp-p typ. (w/ 10 µF X7R) 15 / 5 / -15 VDC model: 150 / 100 / 150 mVp-p typ. (w/ 10 µF X7R) 24 / 5 / 12 VDC model: 240 / 100 / 120 mVp-p typ. (w/ 10 µF X7R)
Capacitive Load	- single output - dual output - triple output	5 VDC model: 20'000 µF max. 12 VDC model: 4'520 µF max. 15 VDC model: 2'900 µF max. 24 VDC model: 1'130 µF max. 12 / 5 VDC model: 2'500 / 3'000 µF max. 15 / 5 VDC model: 1'200 / 3'000 µF max. 24 / 5 VDC model: 625 / 3'000 µF max. 12 / 5 / -12 VDC model: 2'500 / 3'000 / 500 µF max. 15 / 5 / -15 VDC model: 1'200 / 3'000 / 500 µF max. 24 / 5 / 12 VDC model: 625 / 3'000 / 500 µF max.
Minimum Load		Not required (0.5 W for Vout1 and Vout2 if Vout3 = Full Load)
Temperature Coefficient		±0.02 %/K max.
Hold-up Time	- At 115 VAC	16 ms min.
Start-up Time	- At 230 VAC	1'000 ms max.

All specifications valid at nominal voltage, full load and +25°C after warm-up time unless otherwise stated.

Short Circuit Protection		Continuous, Automatic recovery
Output Current Limitation		120 - 160% of I _{out max} . 145% typ. of I _{out max} . (P _{out 1} + P _{out 2})
Overvoltage Protection		125 - 140% of V _{out nom} . (only Output 1)
Transient Response	- Response Deviation - Response Time	3% max. (50% to 75% Load Step) 600 μs typ. (50% to 75% Load Step) (Only Output 1)

Safety Specifications

Safety Standards	- Medical Equipment - Certification Documents	EN 60601-1 IEC 60601-1 ANSI/AAMI ES 60601-1 2 x MOPP (Means Of Patient Protection) www.tracopower.com/overview/tpp65
Protection Class		Class I (Prepared): Connection to PE Class II (Prepared): Reinforced Insulation
Pollution Degree		PD 2
Over Voltage Category		OVC II

EMC Specifications

EMI Emissions	- Conducted Emissions - Radiated Emissions - Harmonic Current Emissions - Voltage Fluctuations & Flicker	EN 60601-1-2 edition 4 (Medical Devices) EN 55011 class B (internal filter) EN 55032 class B (internal filter) FCC Part 18 class B (internal filter) EN 55011 class B (internal filter) EN 55032 class B (internal filter) FCC Part 18 class B (internal filter) EN 61000-3-2, class A EN 61000-3-3
EMS Immunity	- Electrostatic Discharge - RF Electromagnetic Field - EFT (Burst) / Surge - Conducted RF Disturbances - PF Magnetic Field - Voltage Dips & Interruptions	EN 60601-1-2 edition 4 (Medical Devices) Air: EN 61000-4-2, ±15 kV, perf. criteria A Contact: EN 61000-4-2, ±8 kV, perf. criteria A EN 61000-4-3, 20 V/m, perf. criteria A EN 61000-4-4, ±2 kV, perf. criteria A L to L: EN 61000-4-5, ±1 kV, perf. criteria A EN 61000-4-6, 20 V _{rms} , perf. criteria A Continuous: EN 61000-4-8, 30 A/m, perf. criteria A 230 VAC / 50 Hz: EN 61000-4-11 30%, 25 periods, perf. criteria A >95%, 0.5 periods, perf. criteria A >95%, 1 period, perf. criteria A >95%, 250 periods, perf. criteria B 115 VAC / 60 Hz: EN 61000-4-11 30%, 25 periods, perf. criteria A >95%, 0.5 periods, perf. criteria A >95%, 1 period, perf. criteria A >95%, 250 periods, perf. criteria B

General Specifications

Relative Humidity		95% max. (non condensing)
Temperature Ranges	- Operating Temperature - Storage Temperature	-40°C to +85°C -40°C to +85°C
Power Derating	- High Temperature - Low Input Voltage	See application note: www.tracopower.com/overview/tpp65 4 %/V below 90 VAC

All specifications valid at nominal voltage, full load and +25°C after warm-up time unless otherwise stated.

Cooling System		Natural convection (20 LFM)
Altitude During Operation		5'000 m max.
Switching Frequency		50 - 140 kHz (PWM) (Output 1) 750 kHz typ. (PWM) (Output 2) 510 kHz typ. (PWM) (Output 3)
Insulation System		Reinforced Insulation
Working Voltage (rated)		258 VAC
Isolation Test Voltage	- Input to Output, 60 s - Input to Case or PE, 60 s - Output to Case or PE, 60 s	4'000 VAC 2'500 VAC 2'500 VAC
Creepage	- Input to Output	8 mm min.
Clearance	- Input to Output	8 mm min.
Isolation Resistance	- Input to Output, 500 VDC	100 MΩ min.
Leakage Current (at 264 VAC)	- Touch Current	75 μA max.
Reliability	- Calculated MTBF	1'500'000 h (for single output models) 1'000'000 h (for multi output models) (MIL-HDBK-217F, ground benign)
Environment	- Vibration - Mechanical Shock	IEC 60068-2-6 IEC 60068-2-27
Housing Material		Aluminium
Connection Type		Screw Terminal
Weight	- single output - dual output - triple output	172 g 221 g 221 g
Environmental Compliance	- Reach - RoHS	www.tracopower.com/info/reach-declaration.pdf www.tracopower.com/info/rohs-declaration.pdf

Supporting Documents

Overview Link (for additional Documents)

www.tracopower.com/overview/tp65

Outline Dimensions

Single Output Models

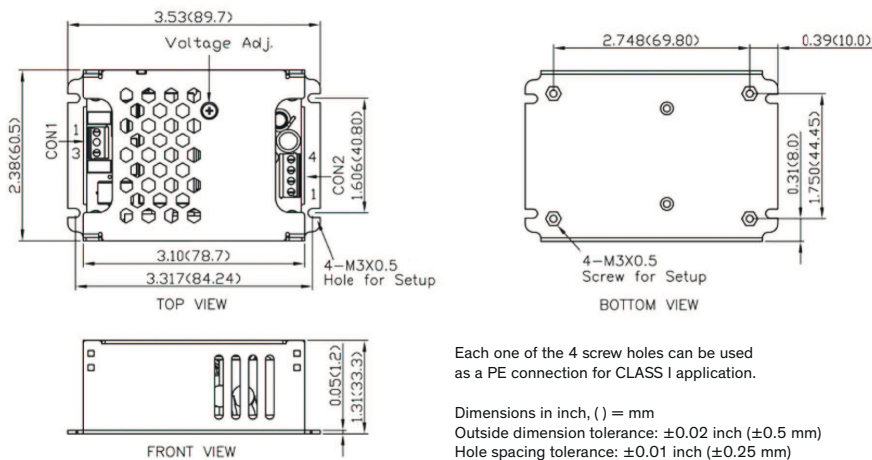

Screw Terminal

Input (CON1)		Output (CON2)	
Pin	Function	Pin*	Function
1	Line	1,2	-Vout
3	Neutral	3,4	+Vout

*Terminal rated for 10 A max.
(at higher current connection has to be split)

CON1: Terminal Block
mates with Screw locked torque MAX 2Kgf.cm/0.2N.m
Wire dimension range: 26 - 16 AWG

CON2: Terminal Block
mates with Screw locked torque MAX 2Kgf.cm/0.2N.m
Wire dimension range: 26 - 16 AWG

All specifications valid at nominal voltage, full load and +25°C after warm-up time unless otherwise stated.

Multi Output Models

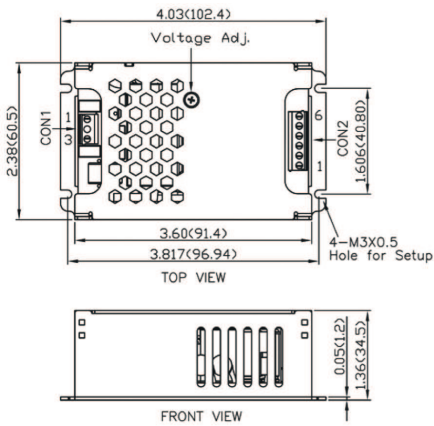

Each one of the 4 screw holes can be used as a PE connection for CLASS I application.

Dimensions in inch, () = mm
 Outside dimension tolerance: ± 0.02 inch (± 0.5 mm)
 Hole spacing tolerance: ± 0.01 inch (± 0.25 mm)

Screw Terminal				
Input (CON1)		Output (CON2)		
Pin	Function	Pin*	Dual	Triple
1	Line	1	NC	Vout 3
3	Neutral	2,3	COM	COM
		4,5	Vout 2	Vout 2
		6	Vout 1	Vout 1

*Terminal rated for 10 A max.
 (at higher current connection has to be split)

CON1: Terminal Block
 mates with Screw locked torque MAX 2Kgf.cm/0.2N.m
 Wire dimension range: 26 - 16 AWG

CON2: Terminal Block
 mates with Screw locked torque MAX 2Kgf.cm/0.2N.m
 Wire dimension range: 26 - 16 AWG