

TPIC6A596 POWER LOGIC 8-BIT SHIFT REGISTER

SLIS094A – MARCH 2000 – REVISED MAY 2005

- Low $r_{DS(on)}$. . . 1 Ω Typ
- Output Short-Circuit Protection
- Avalanche Energy . . . 75 mJ
- Eight 350-mA DMOS Outputs
- 50-V Switching Capability
- Enhanced Cascading for Multiple Stages
- All Registers Cleared With Single Input
- Low Power Consumption

description

The TPIC6A596 is a monolithic, high-voltage, high-current power logic 8-bit shift register designed for use in systems that require relatively high load power. The device contains a built-in voltage clamp on the outputs for inductive transient protection. Power driver applications include relays, solenoids, and other medium-current or high-voltage loads. Each open-drain DMOS transistor features an independent chopping current-limiting circuit to prevent damage in the case of a short circuit.

This device contains an 8-bit serial-in, parallel-out shift register that feeds an 8-bit, D-type storage register. Data transfers through both the shift and storage registers on the rising edge of the shift-register clock (SRCK) and the register clock (RCK), respectively. The storage register transfers data to the output buffer when shift-register clear (\overline{SRCLR}) is high. When \overline{SRCLR} is low, all registers in the device are cleared. When output enable \overline{G} is held high, all data in the output buffers is held low and all drain outputs are off. When \overline{G} is held low, data from the storage register is transparent to the output buffers. The serial output (SER OUT) is clocked out of the device on the falling edge of SRCK to provide additional hold time for cascaded applications. This will provide improved performance for applications where clock signals may be skewed, devices are not located near one another, or the system must tolerate electromagnetic interference.

Outputs are low-side, open-drain DMOS transistors with output ratings of 50 V and a 350-mA continuous sink current capability. When data in the output buffers is low, the DMOS-transistor outputs are off. When data is high, the DMOS-transistor outputs have sink current capability.

Separate power ground (PGND) and logic ground (LGND) terminals are provided to facilitate maximum system flexibility. All PGND terminals are internally connected, and each PGND terminal must be externally connected to the power system ground in order to minimize parasitic impedance. A single-point connection between LGND and PGND must be made externally in a manner that reduces crosstalk between the logic and load circuits.

The TPIC6A596 is offered in a thermally-enhanced dual-in-line (NE) package and a wide-body surface-mount (DW) package. The TPIC6A596 is characterized for operation over the operating case temperature range of -40°C to 125°C .

NE PACKAGE
(TOP VIEW)

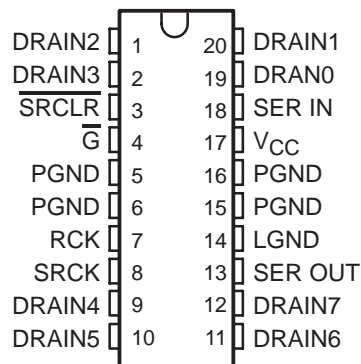

DW PACKAGE
(TOP VIEW)

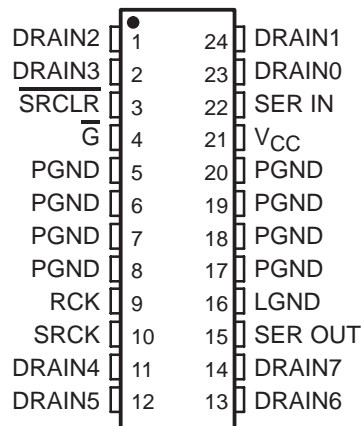

Please be aware that an important notice concerning availability, standard warranty, and use in critical applications of Texas Instruments semiconductor products and disclaimers thereto appears at the end of this data sheet.

PRODUCTION DATA information is current as of publication date. Products conform to specifications per the terms of Texas Instruments standard warranty. Production processing does not necessarily include testing of all parameters.

 **TEXAS
INSTRUMENTS**

POST OFFICE BOX 655303 • DALLAS, TEXAS 75265

Copyright © 2000 – 2005, Texas Instruments Incorporated

TPIC6A596 POWER LOGIC 8-BIT SHIFT REGISTER

SLIS094A – MARCH 2000 – REVISED MAY 2005

logic symbol†

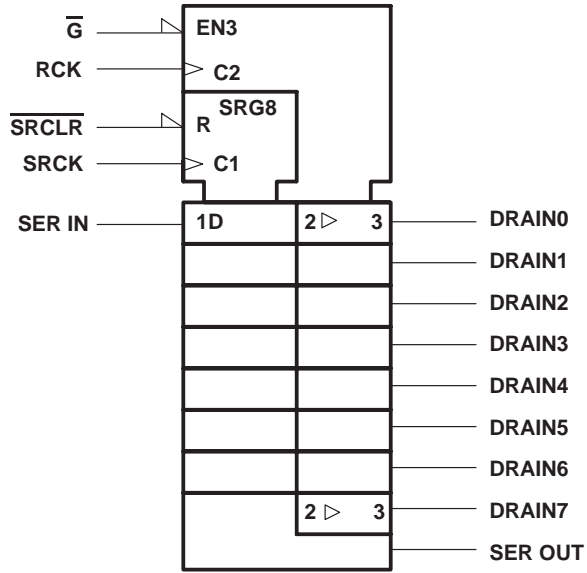

† This symbol is in accordance with ANSI/IEEE Std 91-1984 and IEC Publication 617-12.

logic diagram (positive logic)

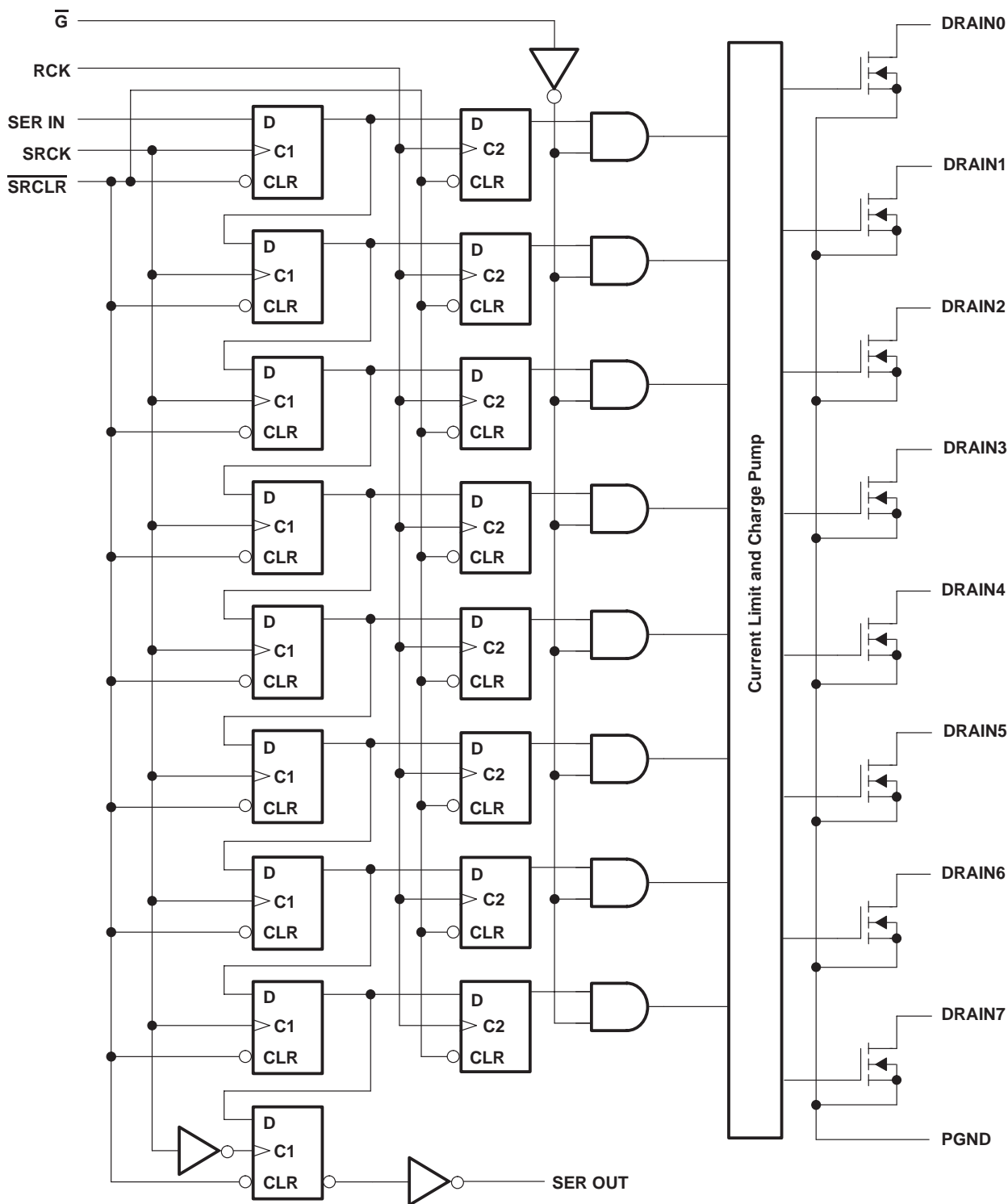

TPIC6A596 POWER LOGIC 8-BIT SHIFT REGISTER

SLIS094A – MARCH 2000 – REVISED MAY 2005

schematic of inputs and outputs

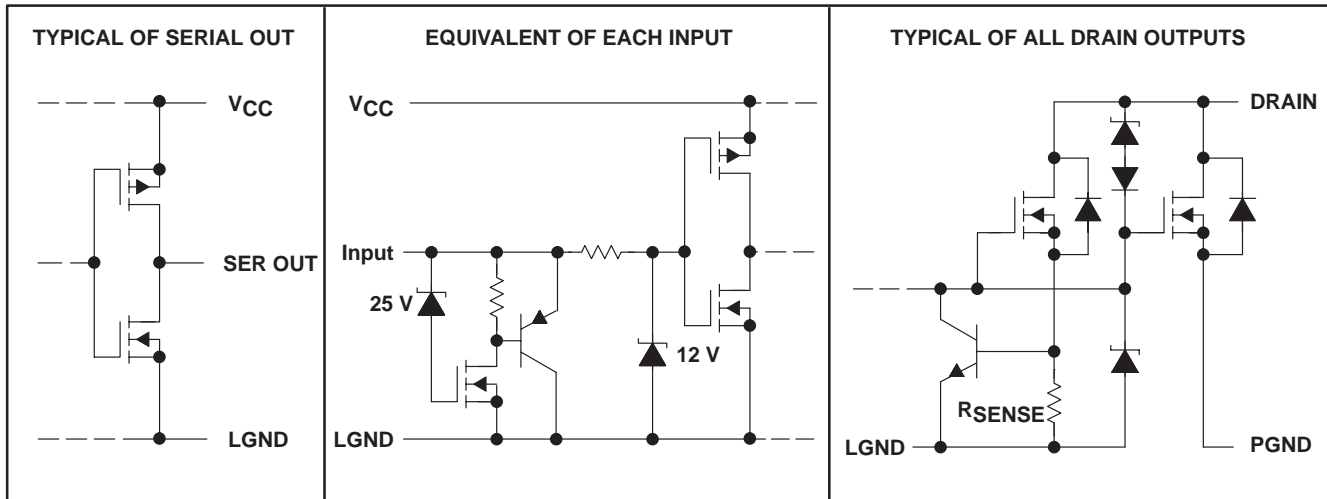

absolute maximum ratings over recommended operating case temperature range (unless otherwise noted)†

Logic supply voltage, V_{CC} (see Note 1)	7 V
Logic input voltage range, V_I	-0.3 V to 7 V
Power DMOS drain-to-source voltage, V_{DS} (see Note 2)	50 V
Continuous source-drain diode anode current	1 A
Pulsed source-drain diode anode current (see Note 3)	2 A
Pulsed drain current, each output, all outputs on, I_{Dn} , $T_A = 25^\circ\text{C}$ (see Note 3)	1.1 A
Continuous drain current, each output, all outputs on, I_{Dn} , $T_A = 25^\circ\text{C}$	350 mA
Peak drain current, single output, $T_A = 25^\circ\text{C}$ (see Note 3)	1.1 A
Single-pulse avalanche energy, E_{AS} (see Figure 6)	75 mJ
Avalanche current, I_{AS} (see Note 4)	600 mA
Continuous total dissipation	See Dissipation Rating Table
Operating case temperature range, T_C	-40°C to 125°C
Operating virtual junction temperature range, T_J	-40°C to 150°C
Storage temperature range, T_{stg}	-65°C to 150°C
Lead temperature 1,6 mm (1/16 inch) from case for 10 seconds	260°C

† Stresses beyond those listed under "absolute maximum ratings" may cause permanent damage to the device. These are stress ratings only, and functional operation of the device at these or any other conditions beyond those indicated under "recommended operating conditions" is not implied. Exposure to absolute-maximum-rated conditions for extended periods may affect device reliability.

- NOTES:
- All voltage values are with respect to LGND and PGND.
 - Each power DMOS source is internally connected to PGND.
 - Pulse duration $\leq 100 \mu\text{s}$ and duty cycle $\leq 2\%$.
 - DRAIN supply voltage = 15 V, starting junction temperature (T_{JS}) = 25°C, $L = 210 \text{ mH}$, $I_{AS} = 600 \text{ mA}$ (see Figure 6).

DISSIPATION RATING TABLE

PACKAGE	$T_C \leq 25^\circ\text{C}$ POWER RATING	DERATING FACTOR ABOVE $T_C = 25^\circ\text{C}$	$T_C = 125^\circ\text{C}$ POWER RATING
DW	1750 mW	14 mW/°C	350 mW
NE	2500 mW	20 mW/°C	500 mW

TPIC6A596 POWER LOGIC 8-BIT SHIFT REGISTER

SLIS094A – MARCH 2000 – REVISED MAY 2005

recommended operating conditions

	MIN	MAX	UNIT
Logic supply voltage, V_{CC}	4.5	5.5	V
High-level input voltage, V_{IH}	$0.85 V_{CC}$	V_{CC}	V
Low-level input voltage, V_{IL}	0	$0.15 V_{CC}$	V
Pulsed drain output current, $T_C = 25^\circ\text{C}$, $V_{CC} = 5\text{ V}$ (see Notes 3 and 5)	-1.8	0.6	A
Setup time, SER IN high before SRCK \uparrow , t_{su} (see Figure 2)	10		ns
Hold time, SER IN high after SRCK \uparrow , t_h (see Figure 2)	10		ns
Pulse duration, t_w (see Figure 2)	20		ns
Operating case temperature, T_C	-40	125	$^\circ\text{C}$

NOTES: 3. Pulse duration $\leq 100\ \mu\text{s}$ and duty cycle $\leq 2\%$.
5. Technique should limit $T_J - T_C$ to 10°C maximum.

electrical characteristics, $V_{CC} = 5\text{ V}$, $T_C = 25^\circ\text{C}$ (unless otherwise noted)

PARAMETER	TEST CONDITIONS	MIN	TYP	MAX	UNIT
$V_{(BR)DSX}$ Drain-to-source breakdown voltage	$I_D = 1\text{ mA}$	50			V
V_{SD} Source-to-drain diode forward voltage	$I_F = 350\text{ mA}$, See Note 3		0.8	1.1	V
V_{OH} High-level output voltage, SER OUT	$I_{OH} = -20\ \mu\text{A}$	$V_{CC} - 0.1$	V_{CC}		V
	$I_{OH} = -4\text{ mA}$	$V_{CC} - 0.5$	$V_{CC} - 0.2$		
V_{OL} Low-level output voltage, SER OUT	$I_{OL} = 20\ \mu\text{A}$		0	0.1	V
	$I_{OL} = 4\text{ mA}$		0.2	0.5	
I_{IH} High-level input current	$V_I = V_{CC}$			1	μA
I_{IL} Low-level input current	$V_I = 0$			-1	μA
$I_{O(chop)}$ Output current at which chopping starts	$T_C = 25^\circ\text{C}$, See Note 5 and Figures 3 and 4	0.6	0.8	1.1	A
I_{CC} Logic supply current	$I_O = 0$, $V_I = V_{CC}$ or 0		0.5	5	mA
$I_{CC(FRQ)}$ Logic supply current at frequency	$f_{SRCK} = 5\text{ MHz}$, $I_O = 0$, $C_L = 30\text{ pF}$, $V_I = V_{CC}$ or 0, $V_{CC} = 5\text{ V}$, See Figure 7		1.3		mA
$I_{(nom)}$ Nominal current	$V_{DS(on)} = 0.5\text{ V}$, $V_{CC} = 5\text{ V}$, $I_{(nom)} = I_D$, $T_C = 85^\circ\text{C}$, See Notes 5, 6, and 7		350		mA
I_D Drain current, off-state	$V_{DS} = 40\text{ V}$, $T_C = 25^\circ\text{C}$		0.1	1	μA
	$V_{DS} = 40\text{ V}$, $T_C = 125^\circ\text{C}$		0.2	5	
$r_{DS(on)}$ Static drain-source on-state resistance	$I_D = 350\text{ mA}$, $T_C = 25^\circ\text{C}$	See Notes 5 and 6 and Figures 10 and 11	1	1.5	Ω
	$I_D = 350\text{ mA}$, $T_C = 125^\circ\text{C}$		1.7	2.5	

NOTES: 5. Technique should limit $T_J - T_C$ to 10°C maximum.
6. These parameters are measured with voltage-sensing contacts separate from the current-carrying contacts.
7. Nominal current is defined for a consistent comparison between devices from different sources. It is the current that produces a voltage drop of 0.5 V at $T_C = 85^\circ\text{C}$.

TPIC6A596 POWER LOGIC 8-BIT SHIFT REGISTER

SLIS094A – MARCH 2000 – REVISED MAY 2005

switching characteristics, $V_{CC} = 5\text{ V}$, $T_C = 25^\circ\text{C}$

PARAMETER		TEST CONDITIONS	MIN	TYP	MAX	UNIT
t_{PHL}	Propagation delay time, high-to-low-level output from \overline{G}	$C_L = 30\text{ pF}$, $I_D = 350\text{ mA}$, See Figures 1, 2, and 12		30		ns
t_{PLH}	Propagation delay time, low-to-high-level output from \overline{G}			125		ns
t_r	Rise time, drain output			60		ns
t_f	Fall time, drain output			30		ns
t_{pd}	Propagation delay time, SRCK \downarrow to SEROUT	$C_L = 30\text{ pF}$, $I_D = 350\text{ mA}$, See Figure 2		20		ns
$f(\text{SRCK})$	Serial clock frequency	$C_L = 30\text{ pF}$, $I_D = 350\text{ mA}$, See Note 8			10	MHz
t_a	Reverse-recovery-current rise time	$I_F = 350\text{ mA}$, $di/dt = 20\text{ A}/\mu\text{s}$, See Notes 5 and 6 and Figure 5		100		ns
t_{rr}	Reverse-recovery time			300		ns

- NOTES: 5. Technique should limit $T_J - T_C$ to 10°C maximum.
 6. These parameters are measured with voltage-sensing contacts separate from the current-carrying contacts.
 8. This is the maximum serial clock frequency assuming cascaded operation where serial data is passed from one stage to a second stage. The clock period allows for SRCK \rightarrow SEROUT propagation delay and setup time plus some timing margin.

thermal resistance

PARAMETER		TEST CONDITIONS	MIN	MAX	UNIT
$R_{\theta JC}$	Thermal resistance, junction-to-case	DW		10	$^\circ\text{C}/\text{W}$
		NE	All eight outputs with equal power	10	
$R_{\theta JA}$	Thermal resistance, junction-to-ambient	DW		50	$^\circ\text{C}/\text{W}$
		NE	All eight outputs with equal power	50	

PARAMETER MEASUREMENT INFORMATION

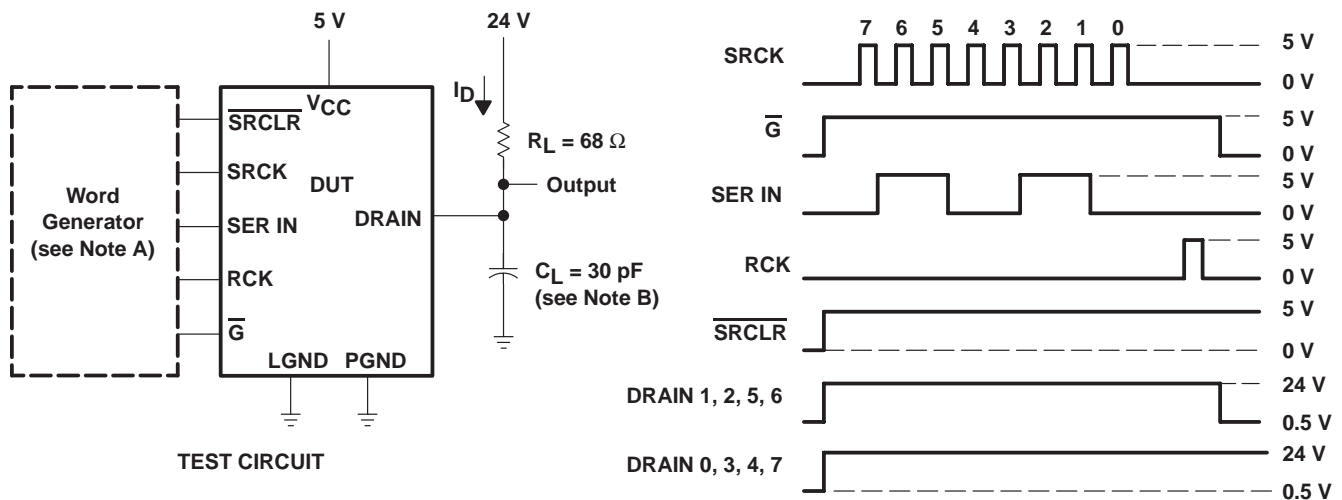

VOLTAGE WAVEFORMS

- NOTES: A. The word generator has the following characteristics: $t_r \leq 10\text{ ns}$, $t_f \leq 10\text{ ns}$, $t_w = 300\text{ ns}$, pulsed repetition rate (PRR) = 5 kHz, $Z_O = 50\ \Omega$.
 B. C_L includes probe and jig capacitance.

Figure 1. Resistive Load Operation

PARAMETER MEASUREMENT INFORMATION

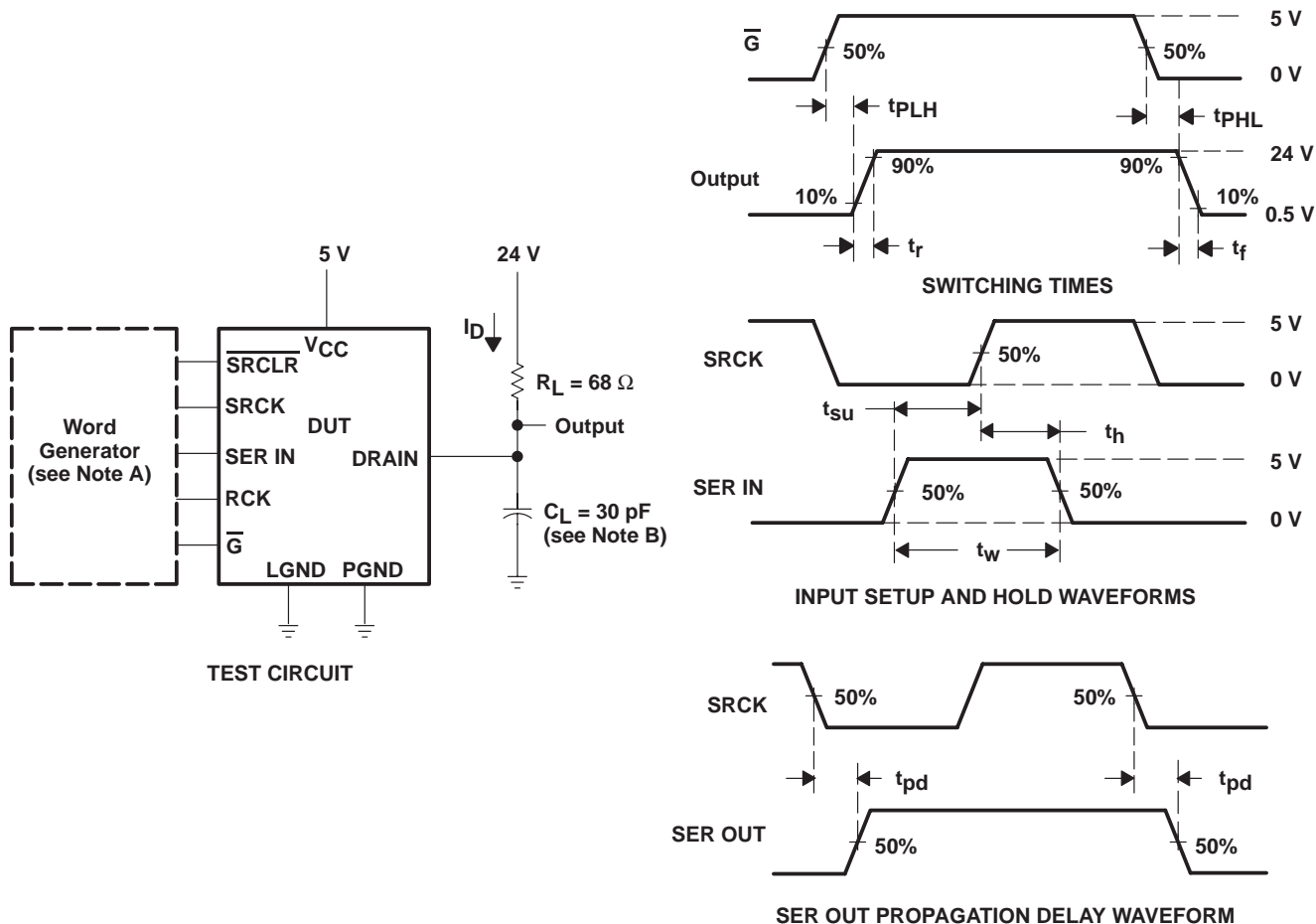

- NOTES: A. The word generator has the following characteristics: $t_r \leq 10 \text{ ns}$, $t_f \leq 10 \text{ ns}$, $t_w = 300 \text{ ns}$, pulsed repetition rate (PRR) = 5 kHz, $Z_O = 50 \Omega$.
B. C_L includes probe and jig capacitance.

Figure 2. Test Circuit, Switching Times, and Voltage Waveforms

TPIC6A596 POWER LOGIC 8-BIT SHIFT REGISTER

SLIS094A – MARCH 2000 – REVISED MAY 2005

PARAMETER MEASUREMENT INFORMATION

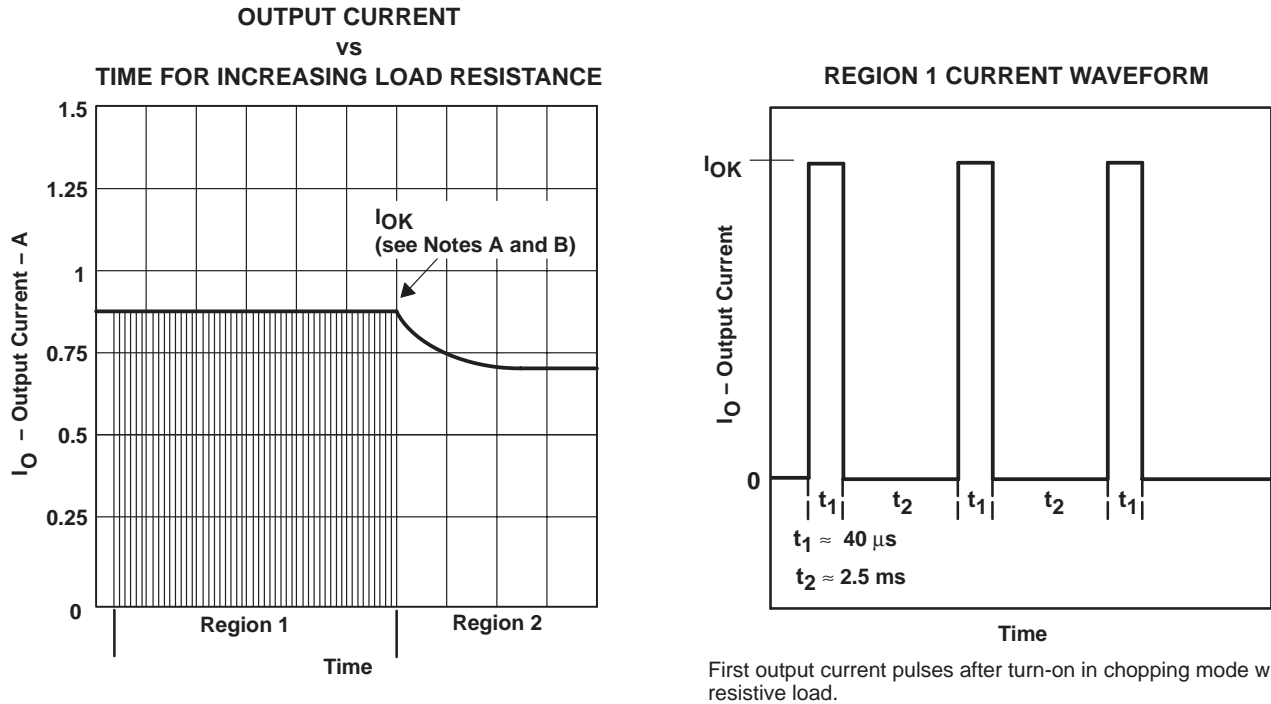

- NOTES: A. Figure 3 illustrates the output current characteristics of the device energizing a load having initially low, increasing resistance, e.g., an incandescent lamp. In region 1, chopping occurs and the peak current is limited to I_{OK} . In region 2, output current is continuous. The same characteristics occur in reverse order when the device energizes a load having an initially high, decreasing resistance.
- B. Region 1 duty cycle is approximately 2%.

Figure 3. Chopping-Mode Characteristics

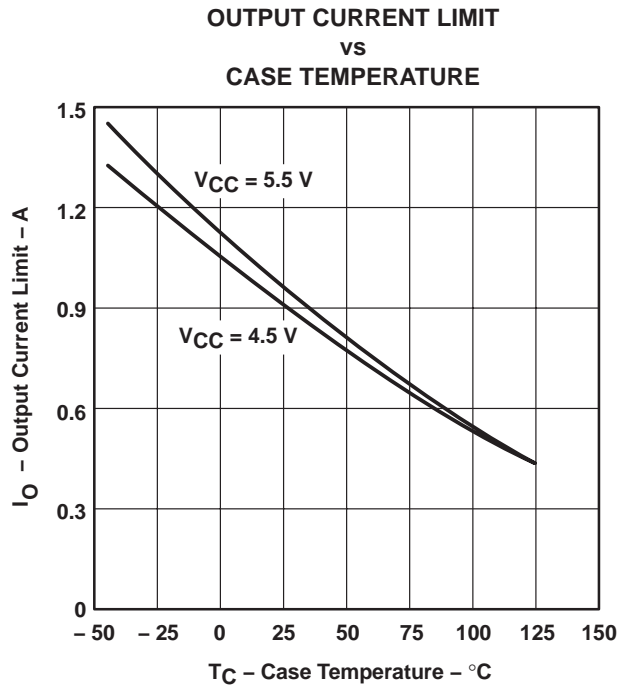
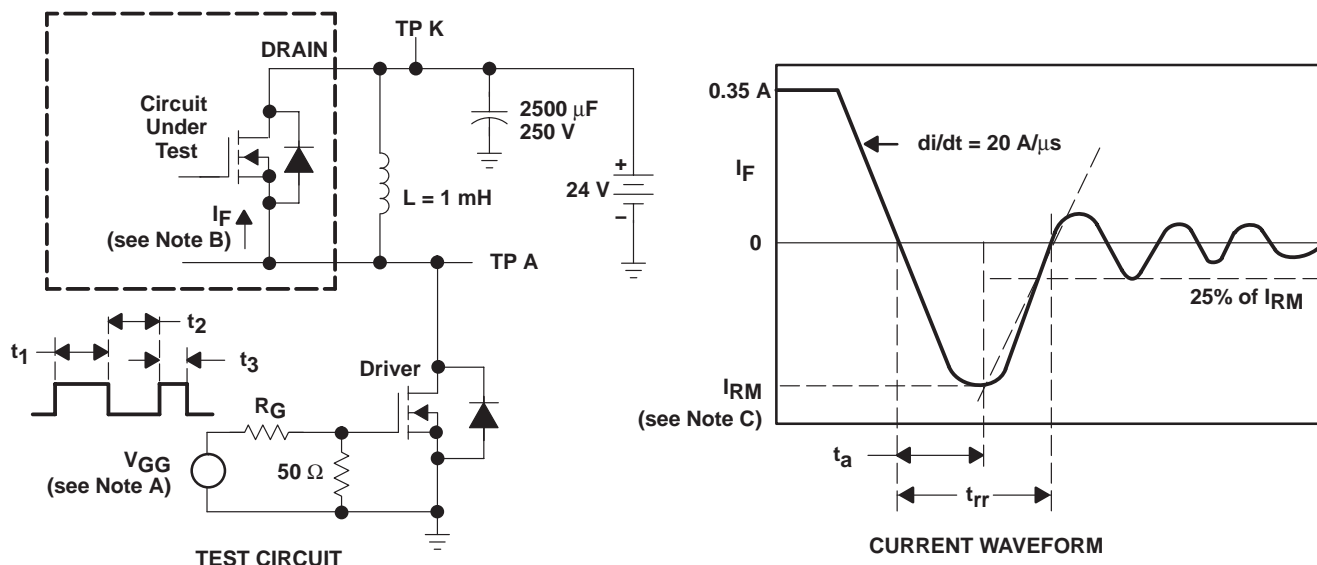

Figure 4



PARAMETER MEASUREMENT INFORMATION



- NOTES: A. The V_{GG} amplitude and R_G are adjusted for $di/dt = 20 \text{ A}/\mu\text{s}$. A V_{GG} double-pulse train is used to set $I_F = 0.35 \text{ A}$, where $t_1 = 10 \mu\text{s}$, $t_2 = 7 \mu\text{s}$, and $t_3 = 3 \mu\text{s}$.
 B. The DRAIN terminal under test is connected to the TP K test point. All other terminals are connected together and connected to the TP A test point.
 C. I_{RM} = maximum recovery current

Figure 5. Reverse-Recovery-Current Test Circuit and Waveforms of Source-Drain Diode

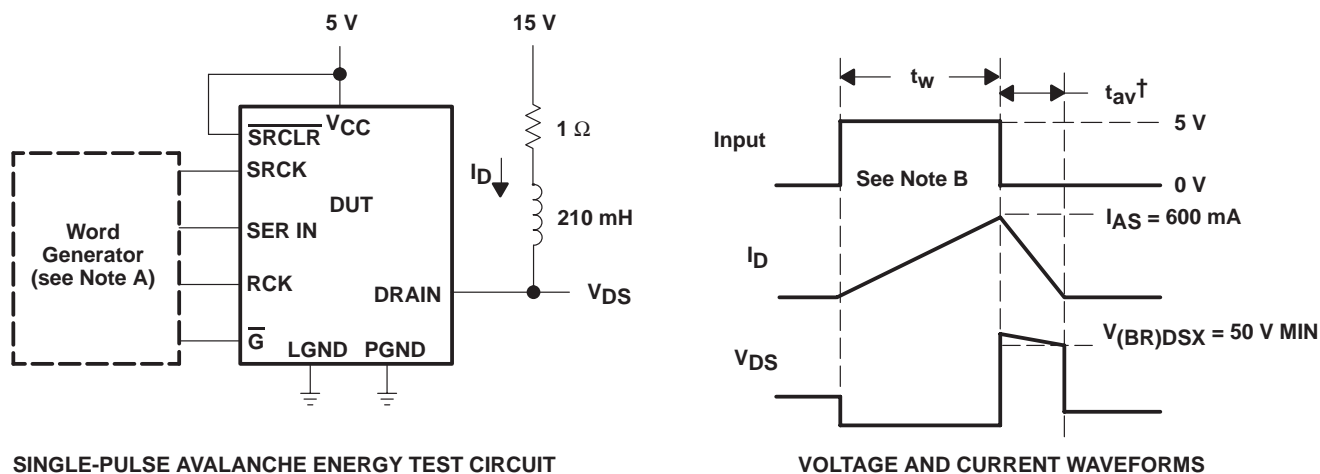

† Non JEDEC symbol for avalanche time.

- NOTES: A. The word generator has the following characteristics: $t_r \leq 10 \text{ ns}$, $t_f \leq 10 \text{ ns}$, $Z_0 = 50 \Omega$.
 B. Input pulse duration, t_w , is increased until peak current $I_{AS} = 600 \text{ mA}$.
 Energy test level is defined as $E_{AS} = (I_{AS} \times V_{(BR)DSX} \times t_{av})/2 = 75 \text{ mJ}$.

Figure 6. Single-Pulse Avalanche Energy Test Circuit and Waveforms

TPIC6A596 POWER LOGIC 8-BIT SHIFT REGISTER

SLIS094A – MARCH 2000 – REVISED MAY 2005

TYPICAL CHARACTERISTICS

**SUPPLY CURRENT
vs
FREQUENCY**

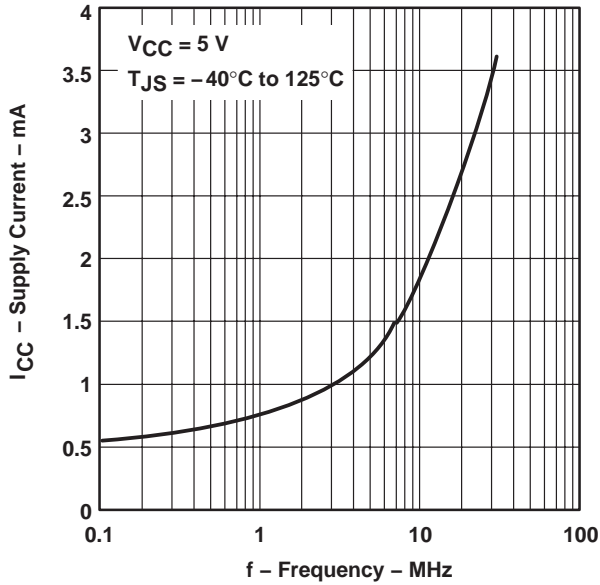

Figure 7

**MAXIMUM CONTINUOUS
DRAIN CURRENT OF EACH OUTPUT
vs
NUMBER OF OUTPUTS CONDUCTING
SIMULTANEOUSLY**

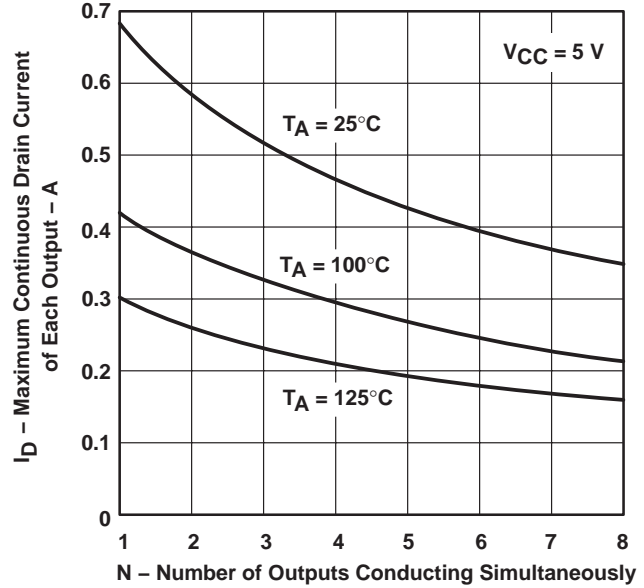

Figure 8

**MAXIMUM PEAK DRAIN CURRENT OF EACH OUTPUT
vs
NUMBER OF OUTPUTS CONDUCTING
SIMULTANEOUSLY**

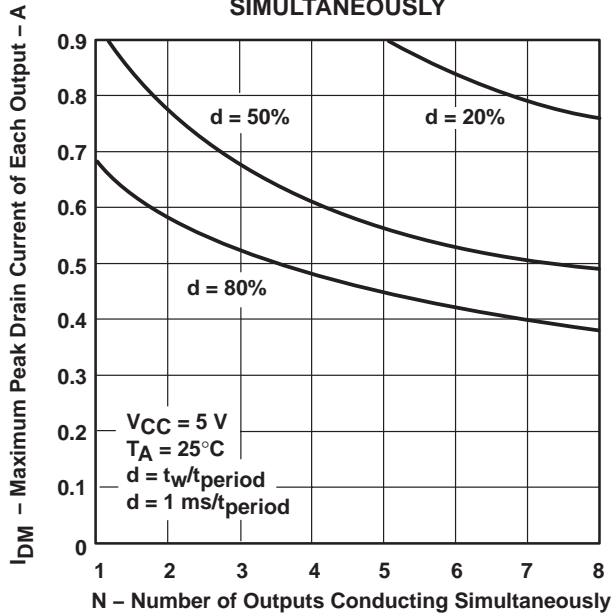

Figure 9

**STATIC DRAIN-SOURCE ON-STATE RESISTANCE
vs
DRAIN CURRENT**

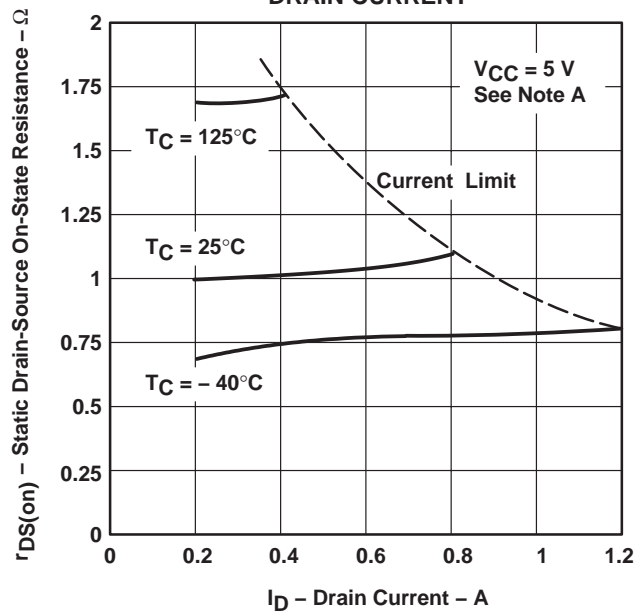

Figure 10

NOTE A: Technique should limit $T_J - T_C$ to 10°C maximum.

TYPICAL CHARACTERISTICS

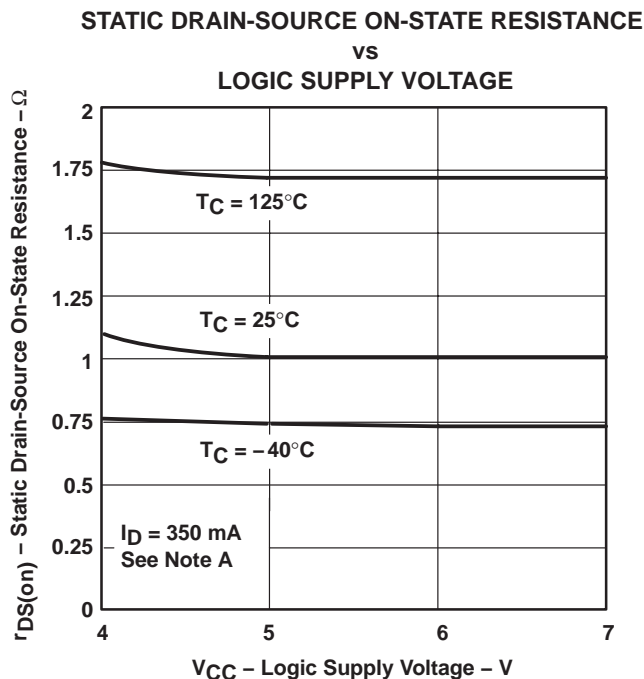

Figure 11

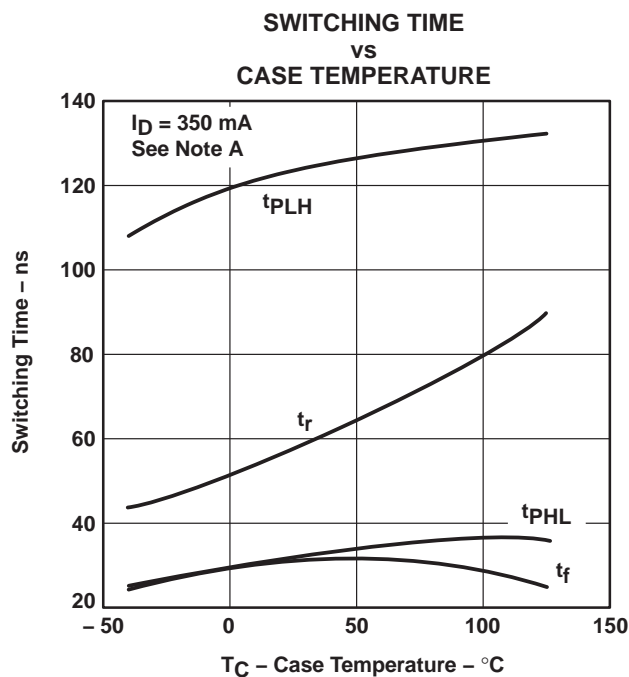

Figure 12

NOTE A: Technique should limit $T_J - T_C$ to 10°C maximum.

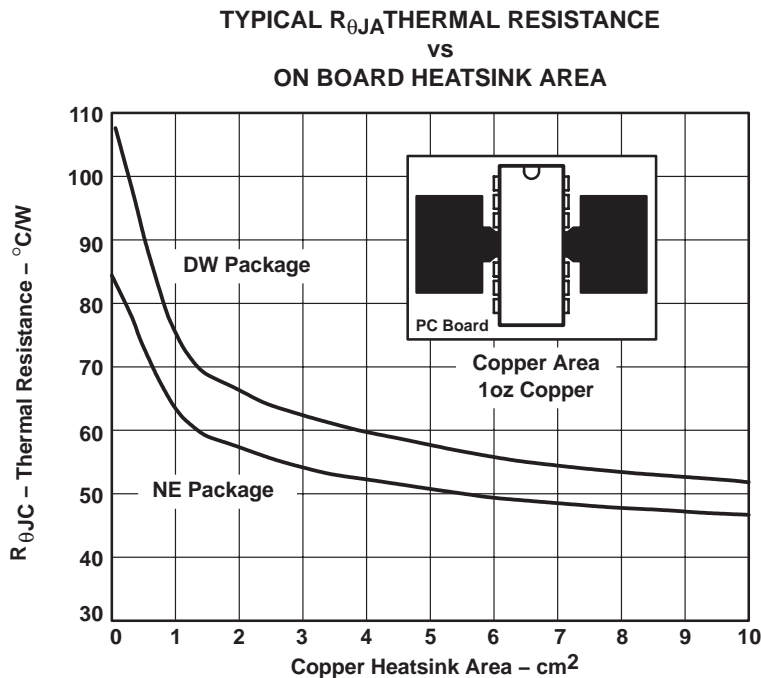
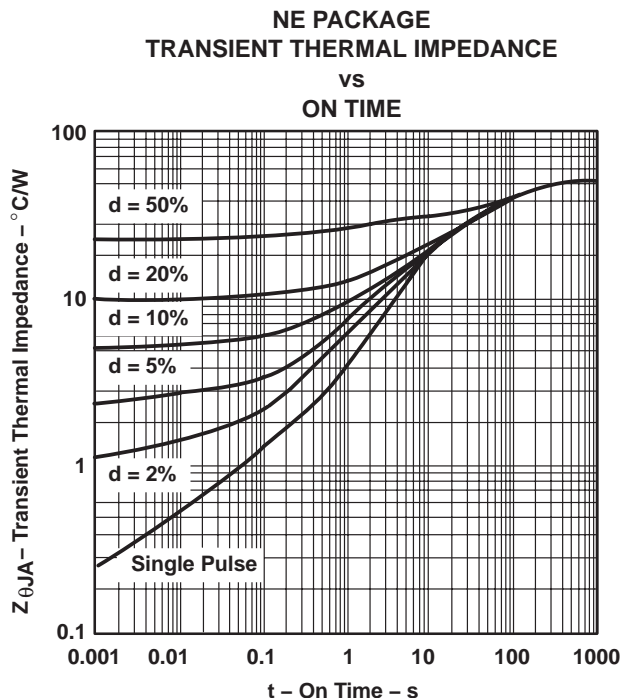

Figure 13

TPIC6A596 POWER LOGIC 8-BIT SHIFT REGISTER

SLIS094A – MARCH 2000 – REVISED MAY 2005

THERMAL INFORMATION



The single-pulse curve represents measured data. The curves for various pulse durations are based on the following equation:

$$Z_{\theta JA} = \left| \frac{t_w}{t_c} \right| R_{\theta JA} + \left| 1 - \frac{t_w}{t_c} \right| Z_{\theta}(t_w + t_c) + Z_{\theta}(t_w) - Z_{\theta}(t_c)$$

Where:

$Z_{\theta}(t_w)$ = the single-pulse thermal impedance for $t = t_w$ seconds

$Z_{\theta}(t_c)$ = the single-pulse thermal impedance for $t = t_c$ seconds

$Z_{\theta}(t_w + t_c)$ = the single-pulse thermal impedance for $t = t_w + t_c$ seconds

$$d = t_w/t_c$$

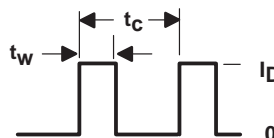

Figure 14

Revision History

DATE	REV	PAGE	SECTION	DESCRIPTION
5/18/05	A	6	Figure 1	Changed \overline{SRCLR} timing diagram and changed title on Drain timing diagrams
3/2000	*			Original reversion

NOTE: Page numbers for previous revisions may differ from page numbers in the current version.

PACKAGING INFORMATION

Orderable Device	Status ⁽¹⁾	Package Type	Package Drawing	Pins	Package Qty	Eco Plan ⁽²⁾	Lead/Ball Finish	MSL Peak Temp ⁽³⁾
TPIC6A596DW	ACTIVE	SOIC	DW	24	25	Green (RoHS & no Sb/Br)	CU NIPDAU	Level-1-260C-UNLIM
TPIC6A596DWG4	ACTIVE	SOIC	DW	24	25	Green (RoHS & no Sb/Br)	CU NIPDAU	Level-1-260C-UNLIM
TPIC6A596DWR	ACTIVE	SOIC	DW	24	2000	TBD	CU NIPDAU	Level-1-220C-UNLIM
TPIC6A596DWRG4	ACTIVE	SOIC	DW	24	2000	Green (RoHS & no Sb/Br)	CU NIPDAU	Level-1-260C-UNLIM
TPIC6A596NE	ACTIVE	PDIP	NE	20	20	Pb-Free (RoHS)	CU NIPDAU	N / A for Pkg Type

⁽¹⁾ The marketing status values are defined as follows:

ACTIVE: Product device recommended for new designs.

LIFEBUY: TI has announced that the device will be discontinued, and a lifetime-buy period is in effect.

NRND: Not recommended for new designs. Device is in production to support existing customers, but TI does not recommend using this part in a new design.

PREVIEW: Device has been announced but is not in production. Samples may or may not be available.

OBSOLETE: TI has discontinued the production of the device.

⁽²⁾ Eco Plan - The planned eco-friendly classification: Pb-Free (RoHS), Pb-Free (RoHS Exempt), or Green (RoHS & no Sb/Br) - please check <http://www.ti.com/productcontent> for the latest availability information and additional product content details.

TBD: The Pb-Free/Green conversion plan has not been defined.

Pb-Free (RoHS): TI's terms "Lead-Free" or "Pb-Free" mean semiconductor products that are compatible with the current RoHS requirements for all 6 substances, including the requirement that lead not exceed 0.1% by weight in homogeneous materials. Where designed to be soldered at high temperatures, TI Pb-Free products are suitable for use in specified lead-free processes.

Pb-Free (RoHS Exempt): This component has a RoHS exemption for either 1) lead-based flip-chip solder bumps used between the die and package, or 2) lead-based die adhesive used between the die and leadframe. The component is otherwise considered Pb-Free (RoHS compatible) as defined above.

Green (RoHS & no Sb/Br): TI defines "Green" to mean Pb-Free (RoHS compatible), and free of Bromine (Br) and Antimony (Sb) based flame retardants (Br or Sb do not exceed 0.1% by weight in homogeneous material)

⁽³⁾ MSL, Peak Temp. -- The Moisture Sensitivity Level rating according to the JEDEC industry standard classifications, and peak solder temperature.

Important Information and Disclaimer:The information provided on this page represents TI's knowledge and belief as of the date that it is provided. TI bases its knowledge and belief on information provided by third parties, and makes no representation or warranty as to the accuracy of such information. Efforts are underway to better integrate information from third parties. TI has taken and continues to take reasonable steps to provide representative and accurate information but may not have conducted destructive testing or chemical analysis on incoming materials and chemicals. TI and TI suppliers consider certain information to be proprietary, and thus CAS numbers and other limited information may not be available for release.

In no event shall TI's liability arising out of such information exceed the total purchase price of the TI part(s) at issue in this document sold by TI to Customer on an annual basis.

TAPE AND REEL BOX DIMENSIONS



*All dimensions are nominal

Device	Package Type	Package Drawing	Pins	SPQ	Length (mm)	Width (mm)	Height (mm)
TPIC6A596DWR	SOIC	DW	24	2000	346.0	346.0	41.0

DW (R-PDSO-G24)

PLASTIC SMALL OUTLINE



- NOTES:
- A. All linear dimensions are in inches (millimeters). Dimensioning and tolerancing per ASME Y14.5M-1994.
 - B. This drawing is subject to change without notice.
 - C. Body dimensions do not include mold flash or protrusion not to exceed 0.006 (0,15).
 - D. Falls within JEDEC MS-013 variation AD.

IMPORTANT NOTICE

Texas Instruments Incorporated and its subsidiaries (TI) reserve the right to make corrections, modifications, enhancements, improvements, and other changes to its products and services at any time and to discontinue any product or service without notice. Customers should obtain the latest relevant information before placing orders and should verify that such information is current and complete. All products are sold subject to TI's terms and conditions of sale supplied at the time of order acknowledgment.

TI warrants performance of its hardware products to the specifications applicable at the time of sale in accordance with TI's standard warranty. Testing and other quality control techniques are used to the extent TI deems necessary to support this warranty. Except where mandated by government requirements, testing of all parameters of each product is not necessarily performed.

TI assumes no liability for applications assistance or customer product design. Customers are responsible for their products and applications using TI components. To minimize the risks associated with customer products and applications, customers should provide adequate design and operating safeguards.

TI does not warrant or represent that any license, either express or implied, is granted under any TI patent right, copyright, mask work right, or other TI intellectual property right relating to any combination, machine, or process in which TI products or services are used. Information published by TI regarding third-party products or services does not constitute a license from TI to use such products or services or a warranty or endorsement thereof. Use of such information may require a license from a third party under the patents or other intellectual property of the third party, or a license from TI under the patents or other intellectual property of TI.

Reproduction of TI information in TI data books or data sheets is permissible only if reproduction is without alteration and is accompanied by all associated warranties, conditions, limitations, and notices. Reproduction of this information with alteration is an unfair and deceptive business practice. TI is not responsible or liable for such altered documentation. Information of third parties may be subject to additional restrictions.

Resale of TI products or services with statements different from or beyond the parameters stated by TI for that product or service voids all express and any implied warranties for the associated TI product or service and is an unfair and deceptive business practice. TI is not responsible or liable for any such statements.

TI products are not authorized for use in safety-critical applications (such as life support) where a failure of the TI product would reasonably be expected to cause severe personal injury or death, unless officers of the parties have executed an agreement specifically governing such use. Buyers represent that they have all necessary expertise in the safety and regulatory ramifications of their applications, and acknowledge and agree that they are solely responsible for all legal, regulatory and safety-related requirements concerning their products and any use of TI products in such safety-critical applications, notwithstanding any applications-related information or support that may be provided by TI. Further, Buyers must fully indemnify TI and its representatives against any damages arising out of the use of TI products in such safety-critical applications.

TI products are neither designed nor intended for use in military/aerospace applications or environments unless the TI products are specifically designated by TI as military-grade or "enhanced plastic." Only products designated by TI as military-grade meet military specifications. Buyers acknowledge and agree that any such use of TI products which TI has not designated as military-grade is solely at the Buyer's risk, and that they are solely responsible for compliance with all legal and regulatory requirements in connection with such use.

TI products are neither designed nor intended for use in automotive applications or environments unless the specific TI products are designated by TI as compliant with ISO/TS 16949 requirements. Buyers acknowledge and agree that, if they use any non-designated products in automotive applications, TI will not be responsible for any failure to meet such requirements.

Following are URLs where you can obtain information on other Texas Instruments products and application solutions:

Products

Audio	www.ti.com/audio
Amplifiers	amplifier.ti.com
Data Converters	dataconverter.ti.com
DLP® Products	www.dlp.com
DSP	dsp.ti.com
Clocks and Timers	www.ti.com/clocks
Interface	interface.ti.com
Logic	logic.ti.com
Power Mgmt	power.ti.com
Microcontrollers	microcontroller.ti.com
RFID	www.ti-rfid.com
RF/IF and ZigBee® Solutions	www.ti.com/lprf

Applications

Communications and Telecom	www.ti.com/communications
Computers and Peripherals	www.ti.com/computers
Consumer Electronics	www.ti.com/consumer-apps
Energy and Lighting	www.ti.com/energy
Industrial	www.ti.com/industrial
Medical	www.ti.com/medical
Security	www.ti.com/security
Space, Avionics and Defense	www.ti.com/space-avionics-defense
Transportation and Automotive	www.ti.com/automotive
Video and Imaging	www.ti.com/video
Wireless	www.ti.com/wireless-apps

TI E2E Community Home Page

e2e.ti.com

Mailing Address: Texas Instruments, Post Office Box 655303, Dallas, Texas 75265
Copyright © 2011, Texas Instruments Incorporated