



TAI-SAW TECHNOLOGY CO., LTD.

No. 3, Industrial 2nd Rd., Ping-Chen Industrial District,
Taoyuan, 324, Taiwan, R.O.C.

TEL: 886-3-4690038 FAX: 886-3-4697532

E-mail: tstsales@mail.taisaw.com Web: www.taisaw.com

Product Specifications Approval Sheet

Product Name: GPS, GLONASS, Beidou and Galileo Front-End Module 1.5x1.1 mm

TST Parts No.: TN0089A (This part is compliant with AEC-Q100)

Customer Part No.: _____

| |
|---------------------|
| Company: _____ |
| Division: _____ |
| Approved by : _____ |
| Date: _____ |

Checked by: _____ Hayley Chou *Hayley Chou*

Approval by: _____ Andy Yu *Andy Yu*

Date: _____ 2018/02/02

1. Customer signed back is required before TST can proceed with sample build and receive orders.
2. Orders received without customer signed back will be regarded as agreement on the specifications.
3. Any specifications changes must be approved upon by both parties and a new revision of specifications shall be released to reflect the changes.



TAI-SAW TECHNOLOGY CO., LTD.

No. 3, Industrial 2nd Rd., Ping-Chen Industrial District,
Taoyuan, 324, Taiwan, R.O.C.

TEL: 886-3-4690038 FAX: 886-3-4697532

E-mail: tstsales@mail.taisaw.com Web: www.taisaw.com

GPS, GLONASS, Beidou and Galileo Front-End Module 1.5x1.1 mm

MODEL NO.: TN0089A

REV. NO.:6.0

A. GENERAL DESCRIPTION:

1. The TN0089A is a front-end module (FEM) designed for GNSS including GPS, GLONASS, BeiDou, and Galileo applications.
2. The TN0089A offers low noise figure, high linearity, and high out-band rejection characteristics brought by included high performance pre-SAW filter and low noise amplifier (LNA).
3. The TN0089A offers only two external components, and very small package that is 1.5x1.1mm.

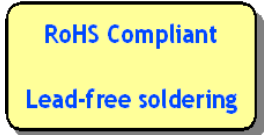

Electrostatic Sensitive Device (ESD)

B. RECOMMENDED OPERATING CONDITION: (Ta=25 °C)

| PARAMETER | SYMBOL | MIN. | TYP. | MAX. | UNIT |
|----------------|-----------------|------|------|------|------|
| Supply Voltage | V _{DD} | 1.5 | - | 3.3 | V |

C. ABSOLUTE MAXIMUM RATINGS:

1. Supply voltage: V_{DD}=5 V
2. Control voltage: V_{CTL}=5 V
3. Input power:
 - P_{IN} (inband): +10 dBm(V_{DD}=2.8 V, f=1575, 1597~1606 MHz)
 - P_{IN} (outband): +25 dBm(V_{DD}=2.8 V, f=50~1460, 1710~4000 MHz)
4. Power dissipation: P_D=500 mW(4-layer FR4 PCB with through-hole(101.5x114.5 mm), T_j=100 °C)
5. Terminating source impedance: Z_s = 50 (Single-ended)
Terminating load impedance: Z_L = 50 (Single-ended)
6. Operating temperature range: -40 °C to +105 °C
7. Storage temperature range: -40 °C to +110 °C

D. FEATURES:

1. Available for GNSS
2. Low supply voltage: 1.8/ 2.8 V typ.
3. Low current consumption:
 - 3.0/3.7mA typ.(at V_{DD}=1.8/ 2.8 V, V_{CTL}=1.8 V)
 - 0.1µA typ.(at V_{DD}=1.8/ 2.8 V, V_{CTL}=0 V (Stand-by mode))
4. High gain: 15.5/16.0dB typ.(at V_{DD}=1.8/2.8 V, V_{CTL}=1.8 V, f=1575 MHz, 1559~1591 MHz)
5. Low noise figure:
 - 1.55/1.50dB typ.(at V_{DD}=1.8/ 2.8 V, V_{CTL}=1.8 V, f=1575 MHz)

- 1.70/1.65dB typ.(at $V_{DD}=1.8/2.8$ V, $V_{CTL}=1.8$ V, $f=1597\sim 1606$ MHz)
 - 1.75/1.70dB typ. (at $V_{DD}=1.8/2.8$ V, $V_{CTL}=1.8$ V, $f=1559\sim 1591$ MHz)
6. High out band rejection(at $V_{DD}=1.8/2.8$ V, $V_{CTL}=1.8$ V):
- 55 dBc typ.($f=704\sim 915$ MHz, relative to 1575 MHz)
 - 43 dBc typ.($f=1710\sim 1980$ MHz, relative to 1575 MHz)
 - 51 dBc typ.($f=2400\sim 2500$ MHz, relative to 1575 MHz)
7. Small package size: HFFP10-CD: 1.5mmx1.1mm (typ.), $t=0.5$ mm (max.)
8. Moisture Sensitivity Level: Level 1

E. ELECTRICAL CHARACTERISTICS 1 (DC):

(General conditions: $T_a=+25$ °C)

| Parameters Description | | Symbol | Unit | Min. | Typ. | Max. |
|------------------------|---|--------------|---------|------|------|------|
| Supply Voltage | | V_{DD} | V | 1.5 | - | 3.3 |
| Control Voltage (High) | | $V_{CTL(H)}$ | V | 1.5 | 1.8 | 3.3 |
| Control Voltage (Low) | | $V_{CTL(L)}$ | V | 0 | 0 | 0.3 |
| Supply Current 1 | RF OFF, $V_{DD}=2.8$ V, $V_{CTL}=1.8$ V | I_{DD1} | mA | - | 3.7 | - |
| Supply Current 2 | RF OFF, $V_{DD}=1.8$ V, $V_{CTL}=1.8$ V | I_{DD2} | mA | - | 3.0 | - |
| Supply Current 3 | RF OFF, $V_{DD}=2.8$ V, $V_{CTL}=0$ V | I_{DD3} | μ A | - | 0.1 | 3.0 |
| Supply Current 4 | RF OFF, $V_{DD}=1.8$ V, $V_{CTL}=0$ V | I_{DD4} | μ A | - | 0.1 | 3.0 |
| Control Current | $V_{CTL}=1.8$ V | I_{CTL} | μ A | - | 5.0 | 12.0 |

F. ELECTRICAL CHARACTERISTICS 2 (RF):

(General conditions: $V_{DD}=2.8$ V, $V_{CTL}=1.8$ V, $f_{RF}=1575$ MHz, 1597~1606, 1559~1591 MHz, $T_a=+25$ °C, $Z_s=Z_l=50$ ohm, with application circuit)

| Parameters Description | | Symbol | Unit | Min. | Typ. | Max. |
|--------------------------------------|--|----------|------|------|------|------|
| Small Signal Gain (GPS)1 | $f=1575$ MHz (GPS) Exclude PCB, Connector Losses(0.17 dB) | GainGPS1 | dB | - | 16.0 | - |
| Small Signal Gain (GLONASS)1 | $f=1597\sim 1606$ MHz (GLONASS) Exclude PCB, Connector Losses(0.17 dB) | GainGLN1 | dB | - | 16.5 | - |
| Small Signal Gain (BeiDou, Galileo)1 | $f=1559\sim 1591$ MHz (BeiDou, Galileo) Exclude PCB, Connector Losses (0.17 dB) | GainBG1 | dB | - | 16.0 | - |
| Noise Figure (GPS)1 | $f=1575$ MHz (GPS)Exclude PCB, Connector Losses (0.09 dB) | NFGPS1 | dB | - | 1.50 | - |
| Noise Figure (GLONASS)1 | $f=1597\sim 1606$ MHz (GLONASS) Exclude PCB, Connector Losses (0.09 dB) | NFGLN1 | dB | - | 1.65 | - |

| | | | | | | |
|---|---|-----------------|-----|---|-------|---|
| Noise Figure (BeiDou, Galileo)1 | f=1559~1591 MHz (BeiDou, Galileo) Exclude PCB, Connector Losses (0.09 dB) | NFBG1 | dB | - | 1.70 | - |
| Input Power at 1dB Gain Compression Point 1 | f=1575, 1597 to 1606, 1559 to 1591 MHz | P-1dB(IN)1 | dBm | - | -10.0 | - |
| Input 3rd Order Intercept Point 1 | f1=1575,1597 to 1606,1559 to 1591 MHz, f2=f1 +/-1 MHz, Pin=-30 dBm | IIP3_1 | dBm | - | -2.0 | - |
| Out of Band Input 2nd Order Intercept Point 1 | f1=824.6 MHz at +15 dBm, f2=2400 MHz at +15 dBm, fmeas=1575.4 MHz | IIP2_OB1 | dBm | - | +80 | - |
| Out of Band Input 3rd Order Intercept Point 1 | f1=1712.7 MHz at +15 dBm, f2=1850 MHz at +15 dBm, fmeas=1575.4 MHz | IIP3_OB1 | dBm | - | +55 | - |
| | Input jammer tone: 787.76 MHz at +15 dBm Measure the harmonic tone at 1575.52 MHz | 2fo1 | dBm | - | -37 | - |
| 700MHz Harmonic1 | fjam=900 MHz, fmeas=1575 MHz at Pin=-40 dBm | P-1dB(IN)_OB1-1 | dBm | - | +24 | - |
| Out-of-Band Input Power 1dB Compression 1 | fjam=1710 MHz, fmeas=1575 MHz at Pin=-40 dBm | P-1dB(IN)_OB1-2 | dBm | - | +24 | - |
| Low Band Rejection 1 | f=704 to 915 MHz, relative to 1575 MHz | BR_L1 | dBc | - | 55 | - |
| High Band Rejection 1 | f=1710 to 1980 MHz, relative to 1575 MHz | BR_H1 | dBc | - | 43 | - |
| WLAN Band Rejection 1 | f=2400 to 2500 MHz, relative to 1575 MHz | BR_W1 | dBc | - | 51 | - |
| RF IN Return Loss (GPS)1 | f=1575 MHz (GPS) | RLiGPS1 | dB | - | 10 | - |
| RF IN Return Loss (GLONASS)1 | f=1597 to 1606 MHz (GLONASS) | RLiGLN1 | dB | - | 15 | - |
| RF IN Return Loss (BeiDou, Galileo)1 | f=1559 to 1591 MHz (BeiDou, Galileo) | RLiBG1 | dB | - | 13 | - |
| RF OUT Return Loss(GPS)1 | f=1575 MHz (GPS) | RLoGPS1 | dB | - | 15 | - |
| RF OUT Return Loss(GLONASS)1 | f=1597 to 1606 MHz (GLONASS) | RLoGLN1 | dB | - | 15 | - |
| RF OUT Return Loss(BeiDou, Galileo)1 | f=1559 to 1591 MHz (BeiDou, Galileo) | RLoBG1 | dB | - | 15 | - |
| Group Delay Time Deviation(GLONASS) 1 | f=1597 to 1606 MHz (GLONASS) | GDTGLN1 | ns | - | 3 | - |
| Group Delay Time Deviation(BeiDou)1 | f=1559 to 1563.2 MHz (BeiDou) | GDTB1 | ns | - | 4 | - |
| Group Delay Time Deviation(Galileo)1 | f=1559 to 1591 MHz (Galileo) | GDTG1 | ns | - | 9 | - |

G. ELECTRICAL CHARACTERISTICS 3 (RF):

(General conditions: $V_{DD}=1.8\text{ V}$, $V_{CTL}=1.8\text{ V}$, $f_{RF}=1575\text{ MHz}$, 1597 to 1606, 1559 to 1591 MHz, $T_a=+25\text{ }^\circ\text{C}$, $Z_s=Z_i=50\text{ ohm}$, with application circuit)

| Parameters Description | | Symbol | Unit | Min. | Typ. | Max. |
|--|--|------------------------|------|------|-------|------|
| Small Signal Gain (GPS) ₂ | f=1575 MHz (GPS) Exclude PCB, Connector Losses (0.17 dB) | GainGPS2 | dB | - | 15.5 | - |
| Small Signal Gain (GLONASS) ₂ | f=1597 to 1606 MHz (GLONASS) Exclude PCB, Connector Losses (0.17 dB) | GainGLN2 | dB | - | 16.0 | - |
| Small Signal Gain (BeiDou, Galileo) ₂ | f=1559 to 1591 MHz (BeiDou, Galileo) Exclude PCB, Connector Losses (0.17 dB) | GainBG2 | dB | - | 15.5 | - |
| Noise Figure (GPS) ₂ | f=1575 MHz (GPS) Exclude PCB, Connector Losses (0.09 dB) | NFGPS2 | dB | - | 1.55 | - |
| Noise Figure (GLONASS) ₂ | f=1597 to 1606 MHz (GLONASS) Exclude PCB, Connector Losses (0.09 dB) | NFGLN2 | dB | - | 1.70 | - |
| Noise Figure (BeiDou, Galileo) ₂ | f=1559 to 1591 MHz (BeiDou, Galileo) Exclude PCB, Connector Losses (0.09 dB) | NFBG2 | dB | - | 1.75 | - |
| Input Power at 1dB Gain Compression Point 2 | f=1575, 1597 to 1606, 1559 to 1591 MHz | P-1dB(IN) ₂ | dBm | - | -13.0 | - |
| Input 3rd Order Intercept Point 2 | f1=1575, 1597 to 1606, 1559 to 1591 MHz, f2=f1 +/-1 MHz, Pin=-30 dBm | IIP3_2 | dBm | - | -5.0 | - |
| Out of Band Input 2nd Order Intercept Point 2 | f1=824.6 MHz at +15 dBm, f2=2400 MHz at +15 dBm, fmeas=1575.4 MHz | IIP2_OB2 | dBm | - | +80 | - |
| Out of Band Input 3rd Order Intercept Point 2 | f1=1712.7 MHz at +15 dBm, f2=1850 MHz at +15 dBm, fmeas=1575.4 MHz | IIP3_OB2 | dBm | - | +55 | - |
| 700MHz Harmonic ₂ | Input jammer tone: 787.76 MHz at +15 dBm Measure the harmonic tone at 1575.52 MHz | 2fo ₂ | dBm | - | -37 | - |
| Out-of-Band Input Power 1dB Compression 2 | fjam=900 MHz, fmeas=1575 MHz at Pin=-40 dBm | P-1dB(IN)_OB2-1 | dBm | - | +24 | - |
| | fjam=1710 MHz, fmeas=1575 MHz at Pin=-40 dBm | P-1dB(IN)_OB2-2 | dBm | - | +24 | - |
| Low Band Rejection 2 | f=704 to 915 MHz, relative to 1575 MHz | BR_L2 | dBc | - | 55 | - |
| High Band Rejection 2 | f=1710 to 1980 MHz, relative to 1575 MHz | BR_H2 | dBc | - | 43 | - |
| WLAN Band Rejection 2 | f=2400 to 2500 MHz, relative to 1575 MHz | BR_W2 | dBc | - | 51 | - |
| RF IN Return Loss (GPS) ₂ | f=1575 MHz (GPS) | RLiGPS2 | dB | - | 10 | - |
| RF IN Return Loss (GLONASS) ₂ | f=1597 to 1606 MHz (GLONASS) | RLiGLN2 | dB | - | 15 | - |

| | | | | | | |
|---------------------------------------|--------------------------------------|---------|----|---|----|---|
| RF IN Return Loss (BeiDou, Galileo)2 | f=1559 to 1591 MHz (BeiDou, Galileo) | RLiBG2 | dB | - | 13 | - |
| RF OUT Return Loss(GPS)2 | f=1575 MHz (GPS) | RLoGPS2 | dB | - | 15 | - |
| RF OUT Return Loss(GLONASS)2 | f=1597 to 1606 MHz (GLONASS) | RLoGLN2 | dB | - | 15 | - |
| RF OUT Return Loss(BeiDou, Galileo)2 | f=1559 to 1591 MHz (BeiDou, Galileo) | RLoBG2 | dB | - | 15 | - |
| Group Delay Time Deviation(GLONASS) 2 | f=1597 to 1606 MHz (GLONASS) | GDTGLN2 | ns | - | 3 | - |
| Group Delay Time Deviation(BeiDou)2 | f=1559 to 1563.2 MHz (BeiDou) | GDTB2 | ns | - | 4 | - |
| Group Delay Time Deviation (Galileo)2 | f=1559 to 1591 MHz (Galileo) | GDTG2 | ns | - | 9 | - |

H. FREQUENCY CHARACTERISTICS 1:

(Conditions: $V_{DD}=2.8$ V, $V_{CTL}=1.8$ V, $T_a=25$ °C, $Z_s=Z_l=50$ ohm, with application circuit.)

Transfer function:

S21 response (span: 250 MHz)

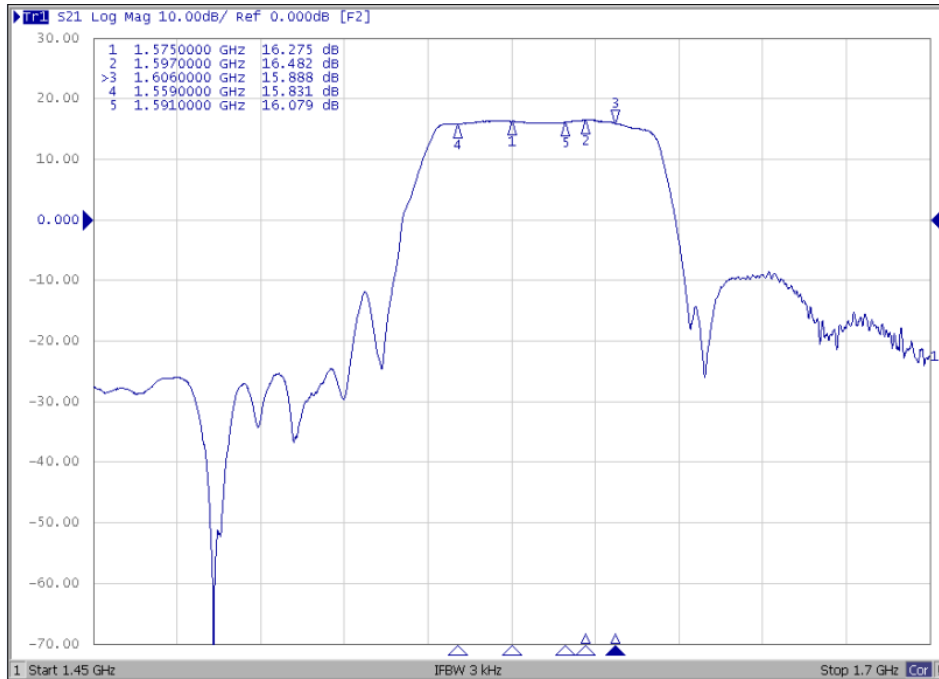

S21 response

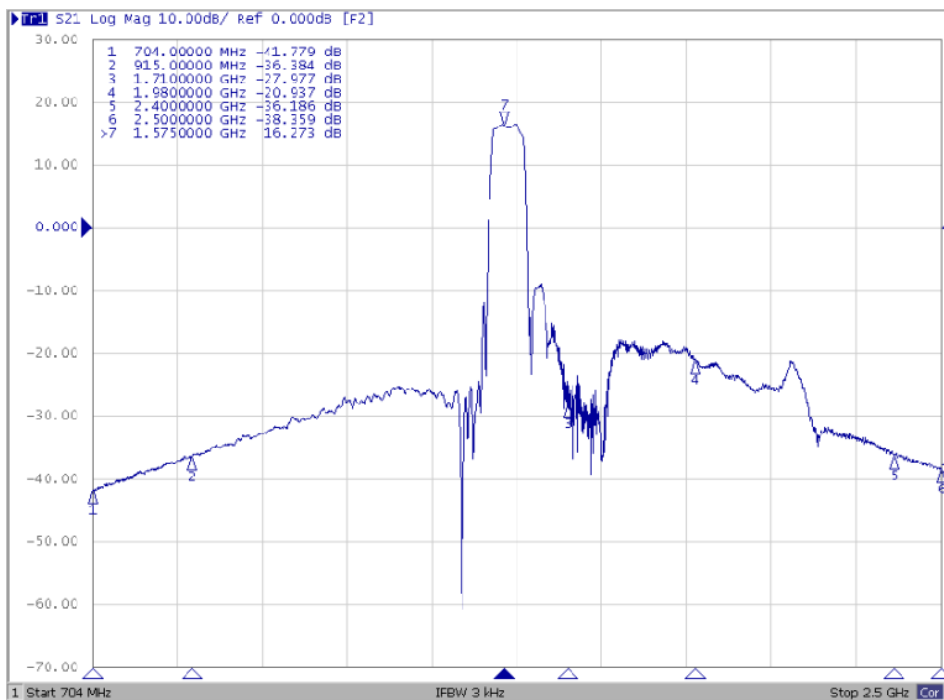

Group Delay

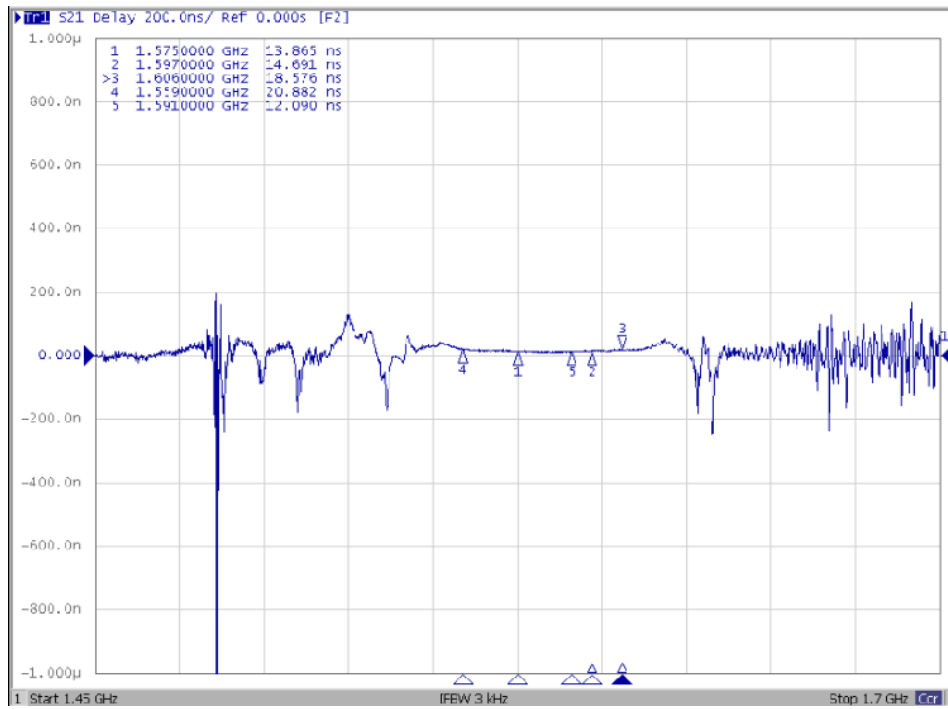

Reflection functions:

S11 VSWR

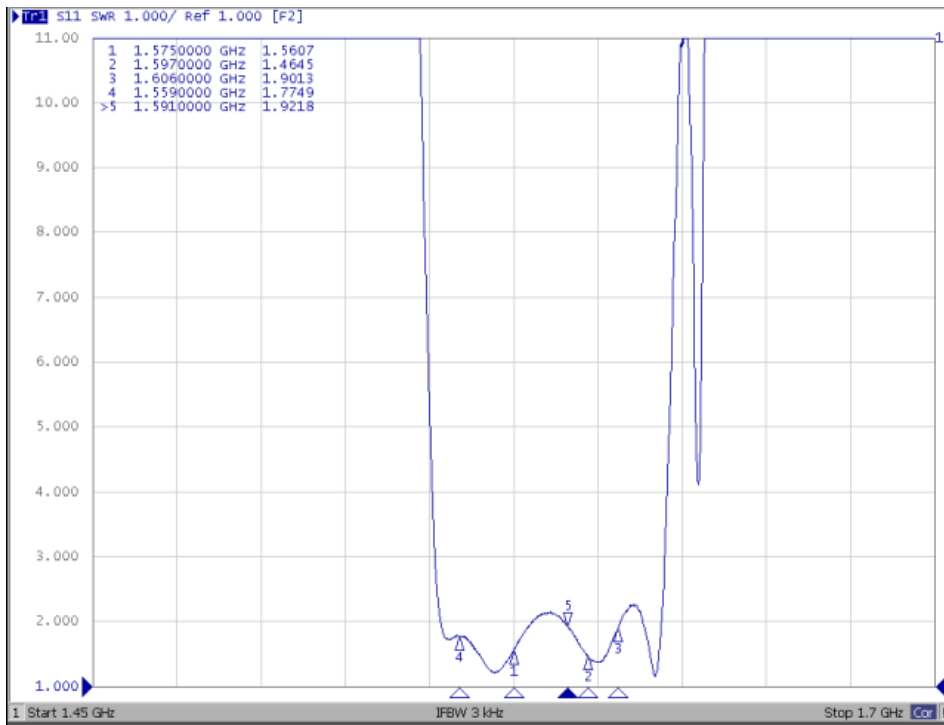

S22 VSWR

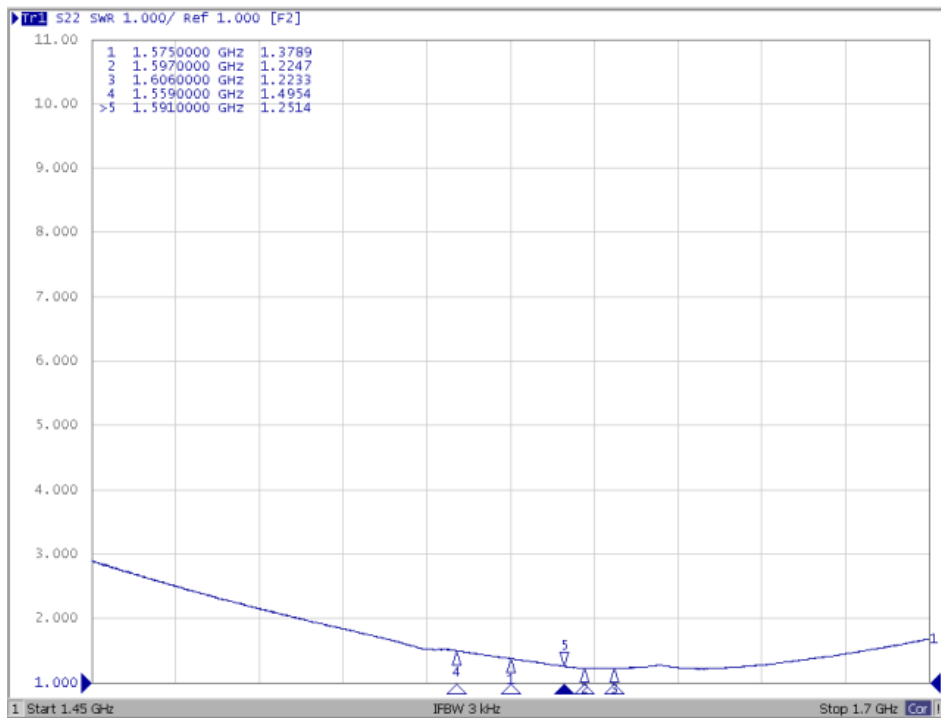

S11 Smith Chart

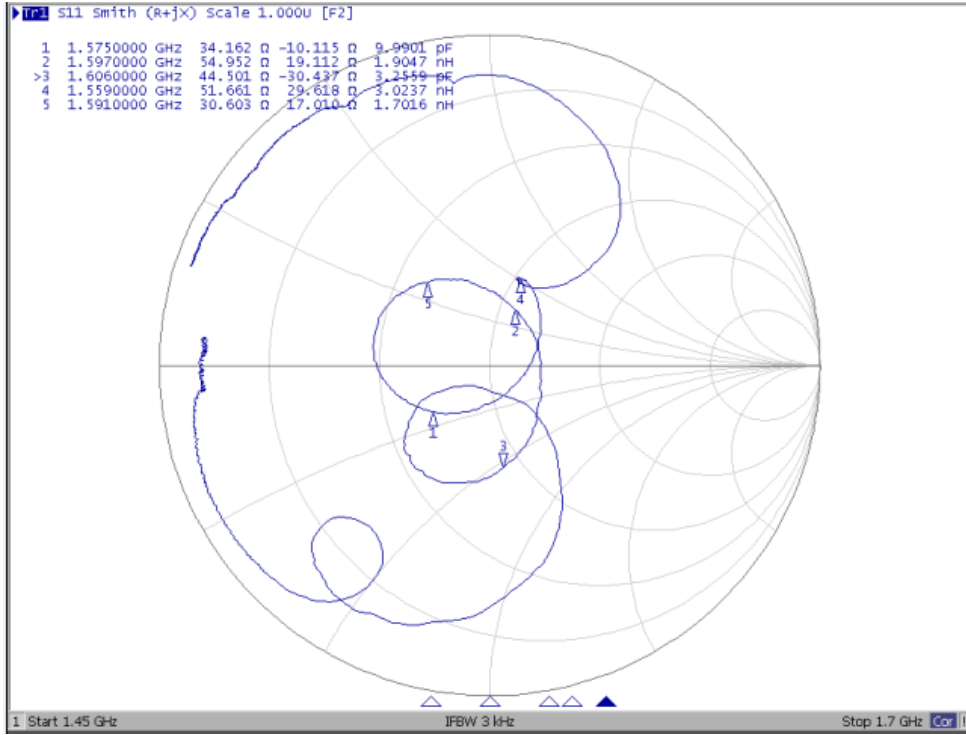

S22 Smith Chart

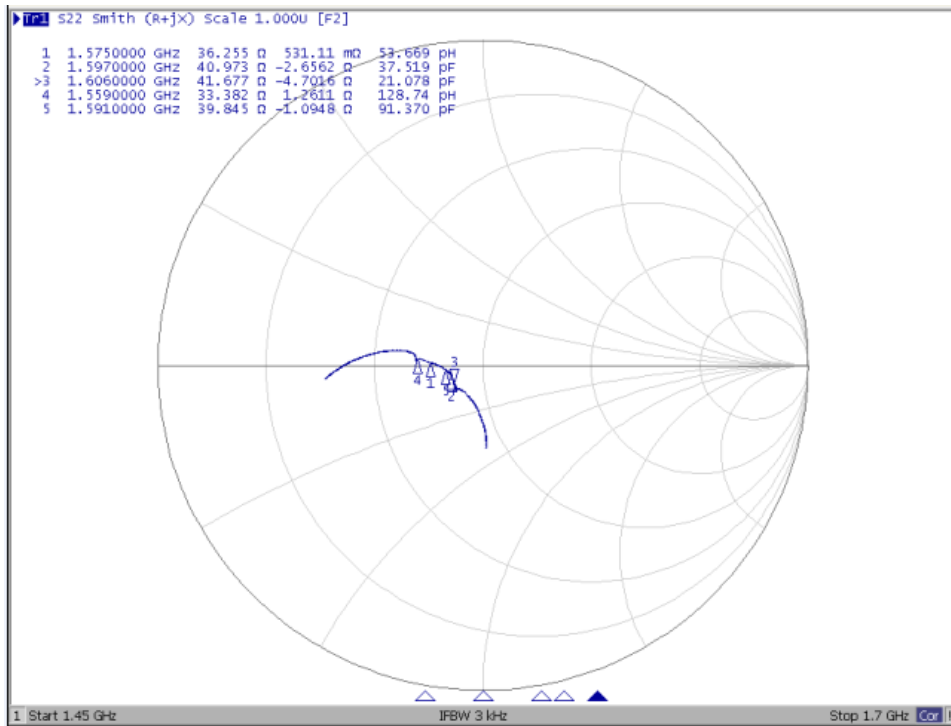

S11 Return Loss

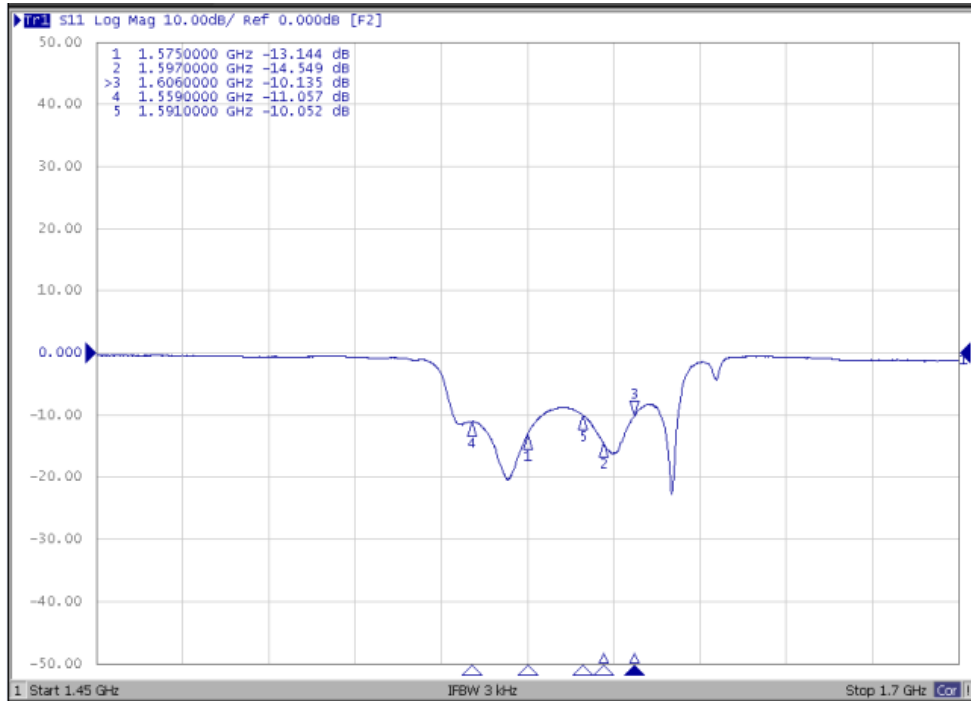

S11 Return Loss

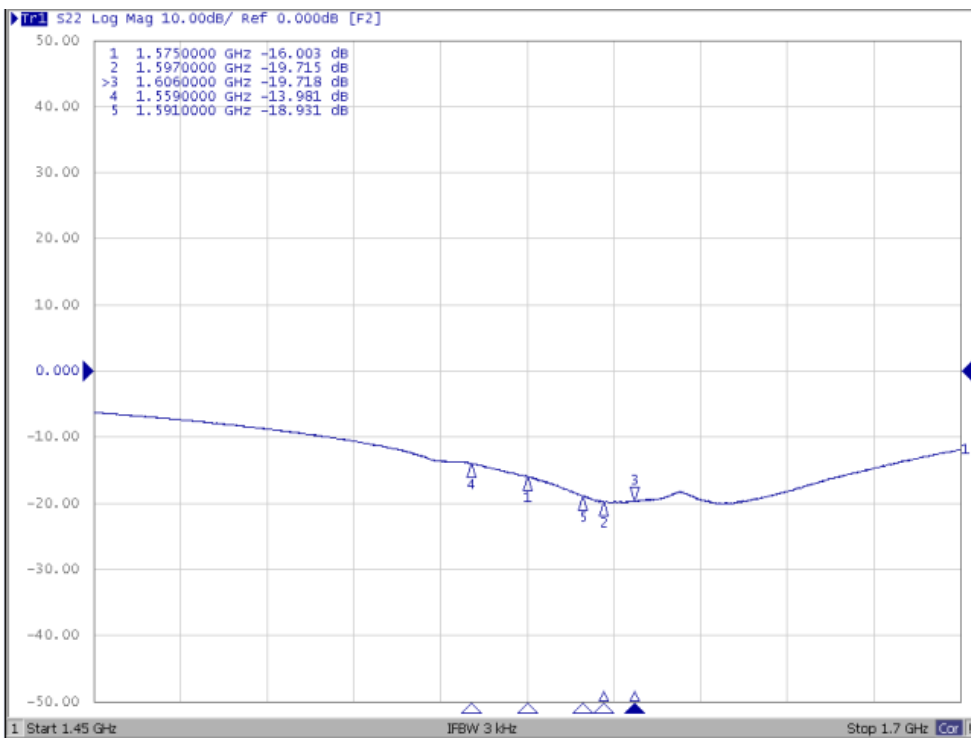

I. FREQUENCY CHARACTERISTICS 2:

(Conditions: $V_{DD}=1.8V$, $V_{CTL}=1.8V$, $T_a=25^{\circ}C$, $Z_s=Z_l=50\text{ ohm}$, with application circuit.)

Transfer function:

S21 response (span: 250 MHz)

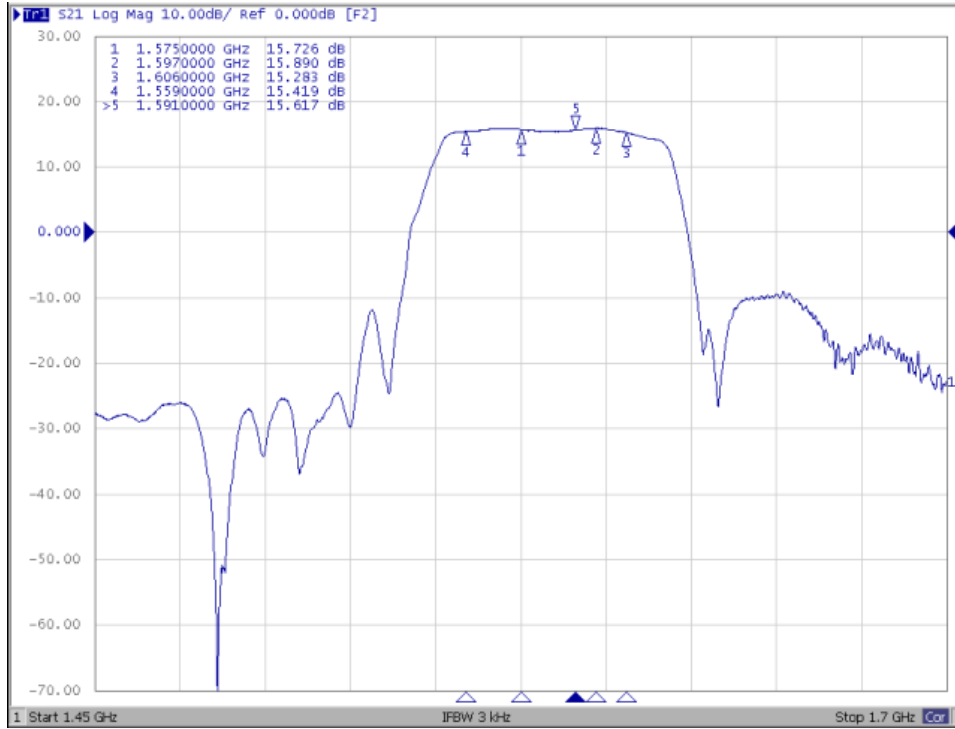

S21 response

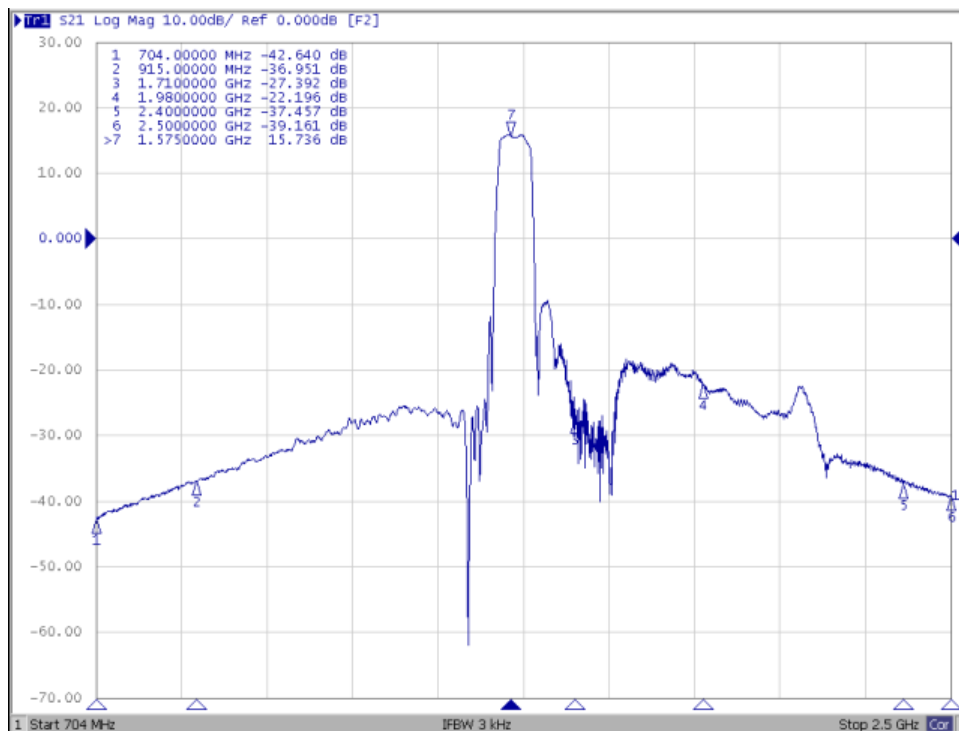

Group Delay

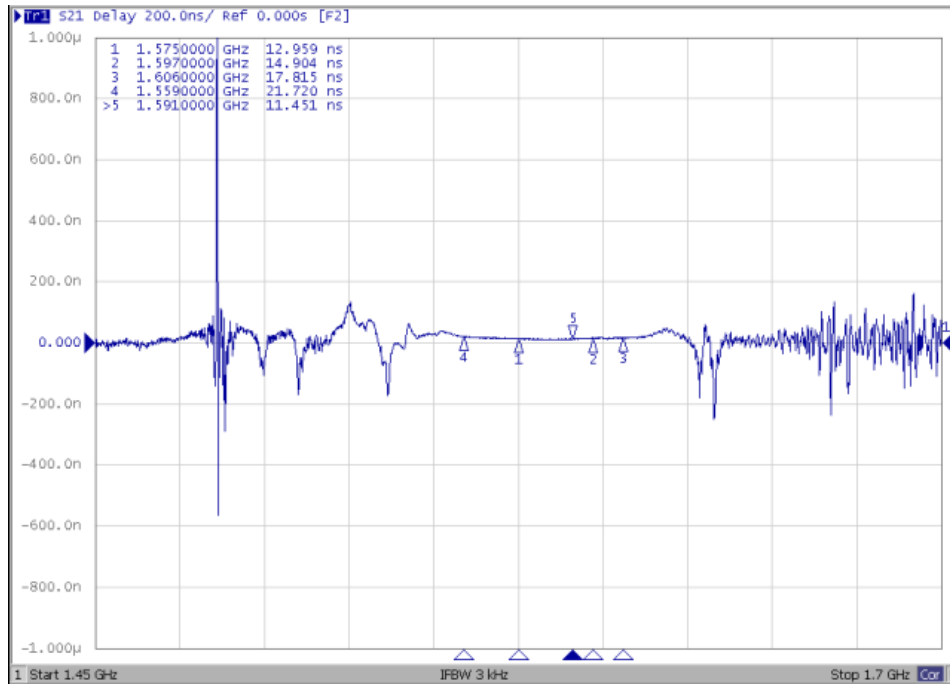

Reflection functions:

S11 VSWR

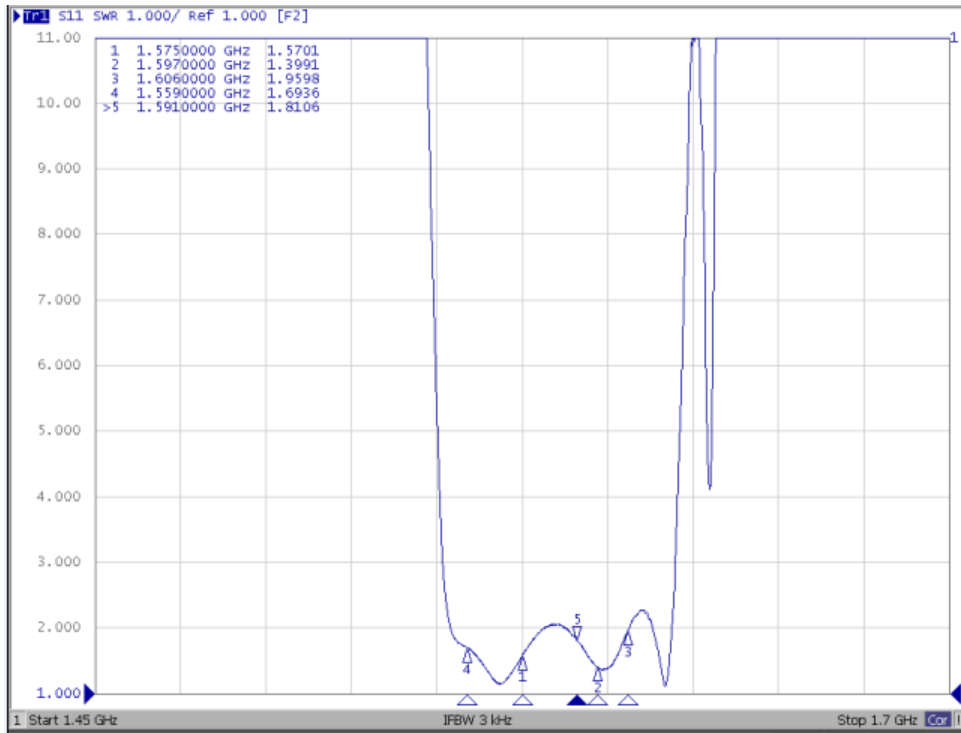

S22 VSWR



S11 Smith Chart

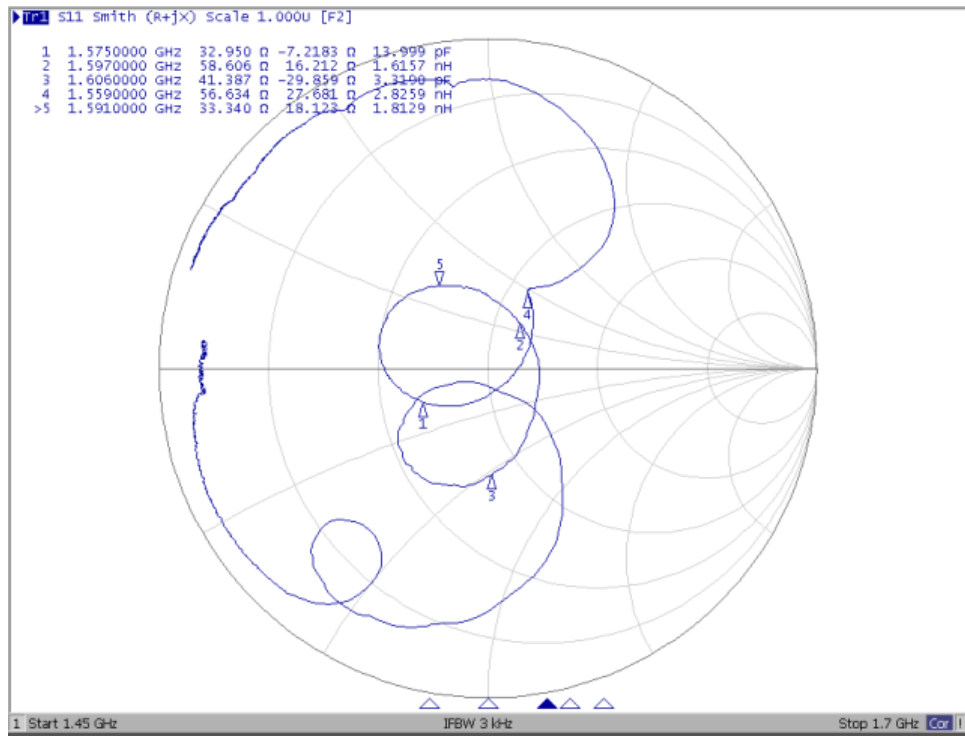

S22 Smith Chart

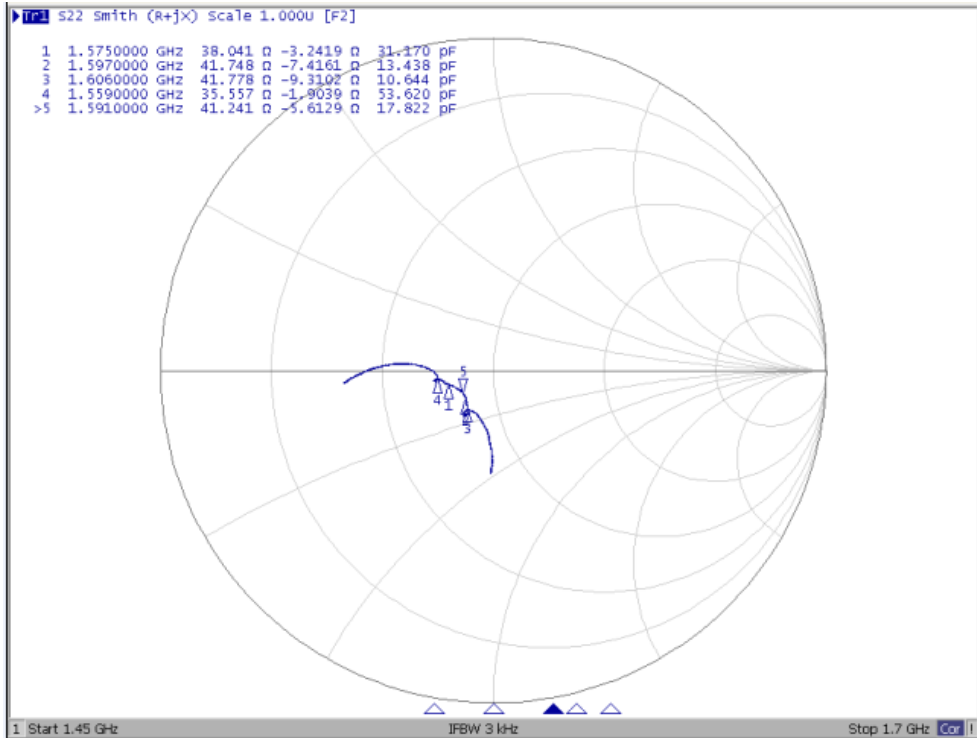

S11 Return Loss

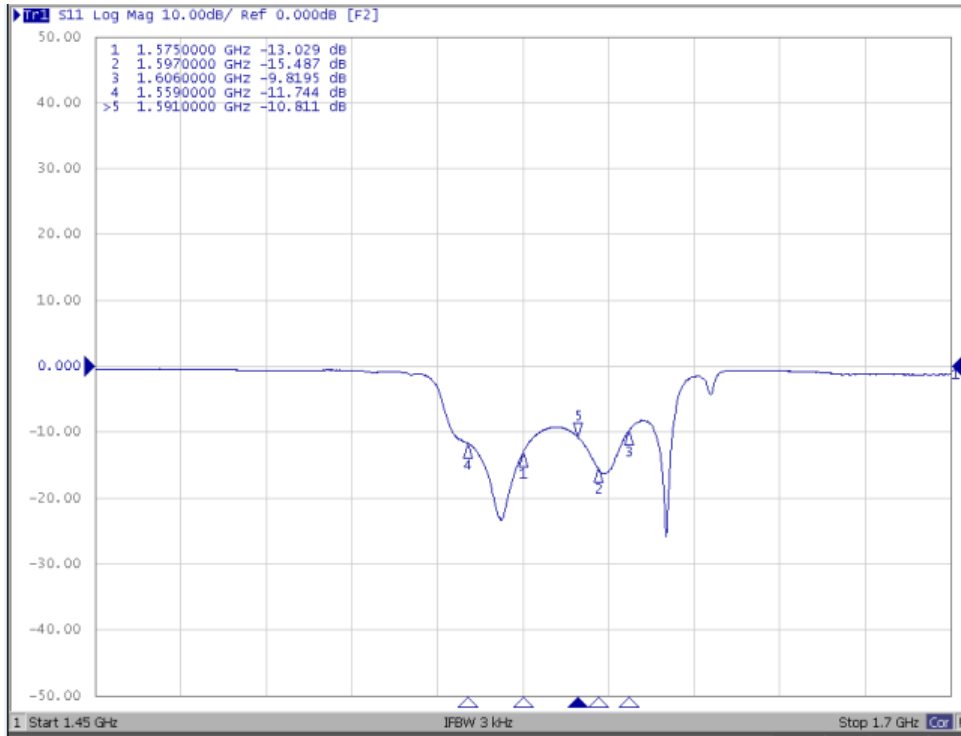

S22 Return Loss

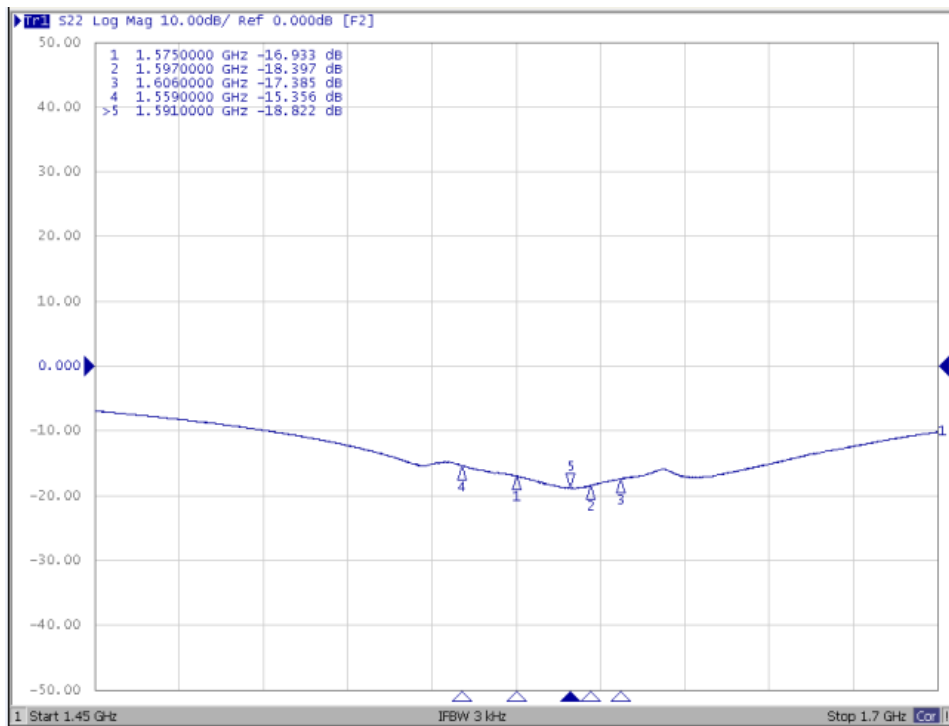

J. MEASUREMENT CIRCUIT:

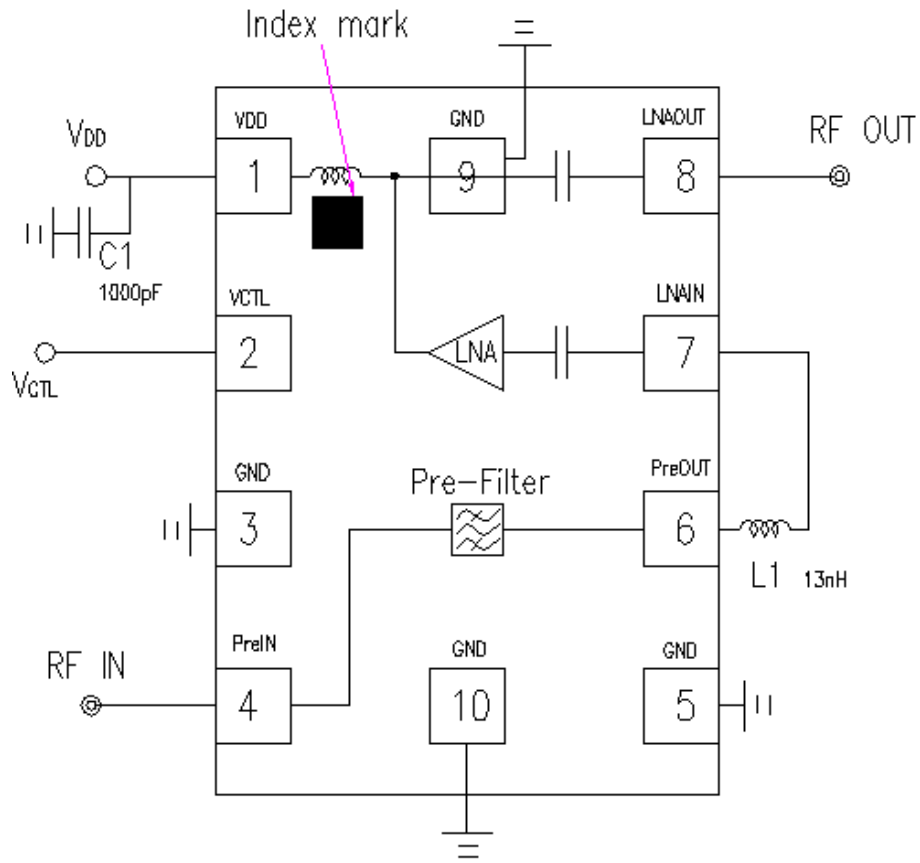

Top View

Parts list

| Parts ID | Manufacture |
|----------|------------------------|
| L1 | LQW15A Series (MURATA) |
| C1 | GRM03 Series (MURATA) |

K. PACKAGE OUTLINE:

UNIT: mm

Top View

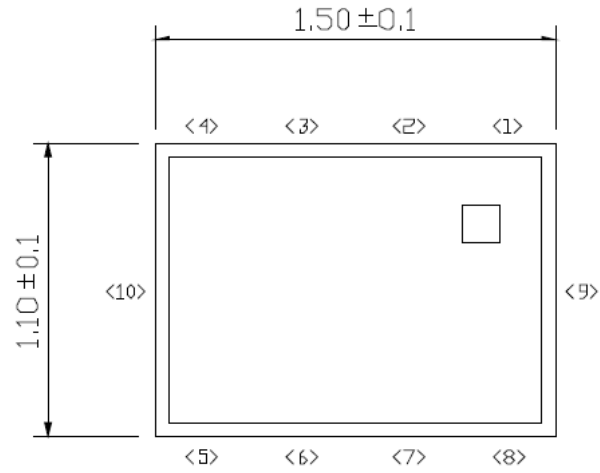

Side View

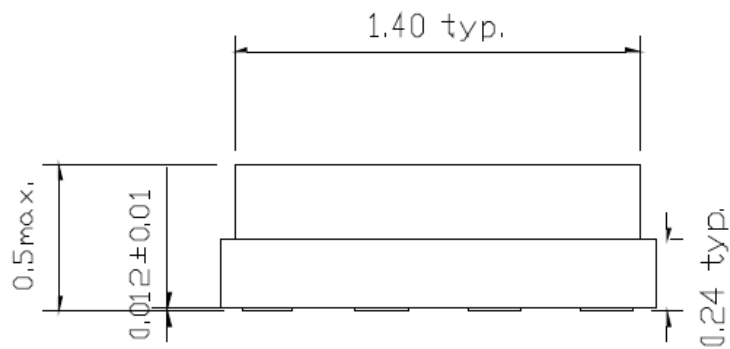

Bottom View

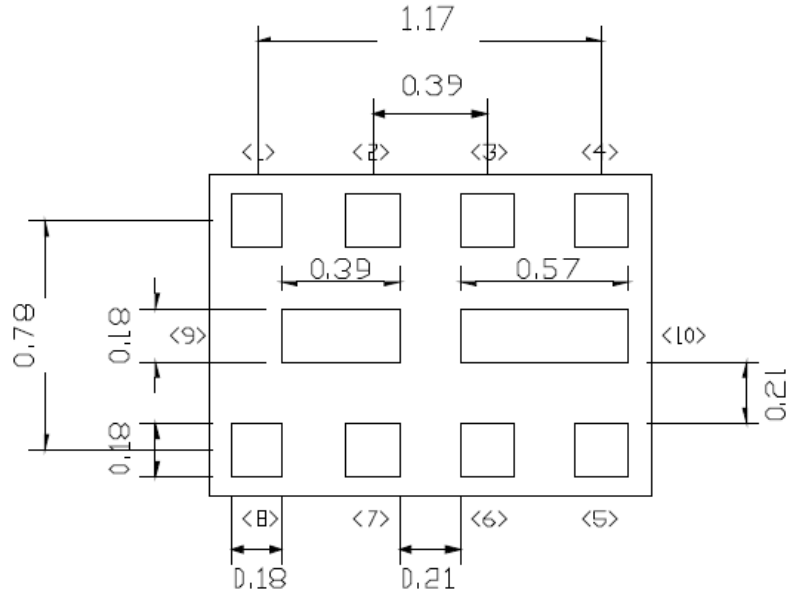

Electrode Dimensions clearance: ± 0.05 mm

Stand-off: 0.1 mm max.

Substrate: Ceramic

Terminal treat: Au

Lid: SnAg/Kovar/Ni

Weight (typ.): 5 mg

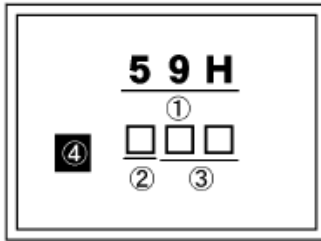

- ① Device No. (59H)
- ② Year-Month of manufacture

| | Jan. | Feb. | Mar. | Apr. | May | Jun. | Jul. | Aug. | Sep. | Oct. | Nov. | Dec. |
|------|------|------|------|------|-----|------|------|------|------|------|------|------|
| 2014 | N | P | Q | R | S | T | U | V | W | X | Y | Z |
| 2015 | a | b | c | d | e | f | g | h | j | k | l | m |
| 2016 | n | p | q | r | s | t | u | v | w | x | y | z |
| 2017 | A | B | C | D | E | F | G | H | J | K | L | M |

- ③ Lot No.
- ④ Index Mark

L. PIN CONFIGURATION:

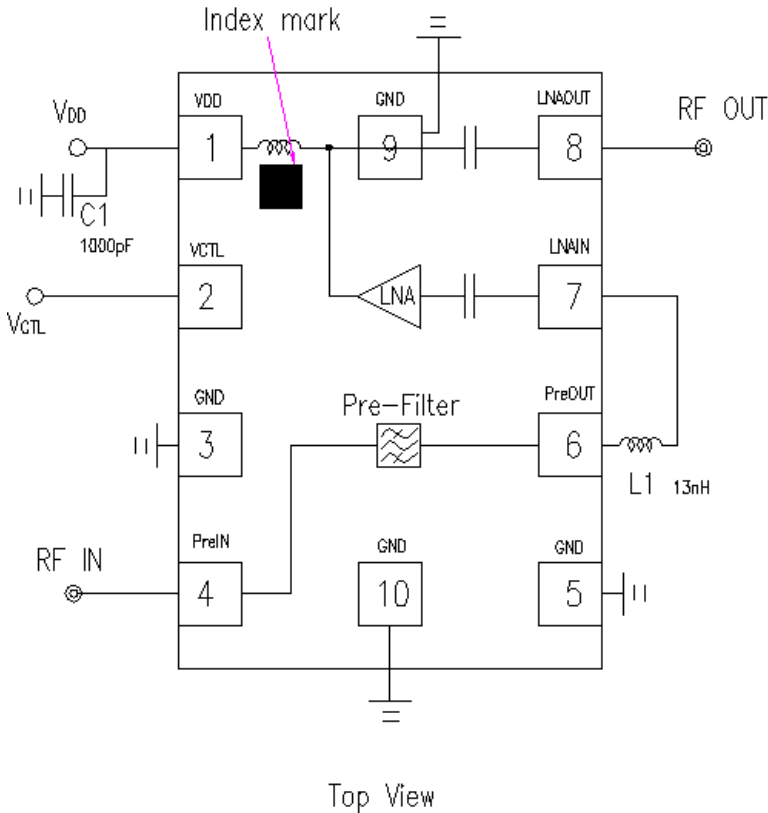

TRUTH TABLE

“H”= $V_{CTL}(H)$, “L”= $V_{CTL}(L)$

| VCTL | Mode |
|------|---------------|
| H | Active mode |
| L | Stand-by mode |

| No. | SYMBOL | DESCRIPTION |
|-----|--------|--|
| 1 | VDD | Supply voltage terminal. Please connect bypass capacitor C1 with ground as close as possible. |
| 2 | VCTL | Control voltage terminal. |
| 3 | GND | Ground terminal. This terminal should be connected to the ground plane as close as possible for excellent RF performance. |
| 4 | PreIN | RF input terminal. This terminal connects to input of pre-SAW filter. |
| 5 | GND | Ground terminal. This terminal should be connected to the ground plane as close as possible for excellent RF performance. |
| 6 | PreOUT | Pre-SAW filter output terminal. This terminal connects to LNAIN with L1. |
| 7 | LNAIN | RF input terminal. This terminal requires only a matching inductor L1, and does not require DC blocking capacitor because of integrated capacitor. |
| 8 | LNAOUT | RF output terminal. This terminal requires no DC blocking capacitor since this terminal has integrated DC blocking capacitor. |
| 9 | GND | Ground terminal. This terminal should be connected to the ground plane as close as possible for excellent RF performance. |
| 10 | GND | Ground terminal. This terminal should be connected to the ground plane as close as possible for excellent RF performance. |



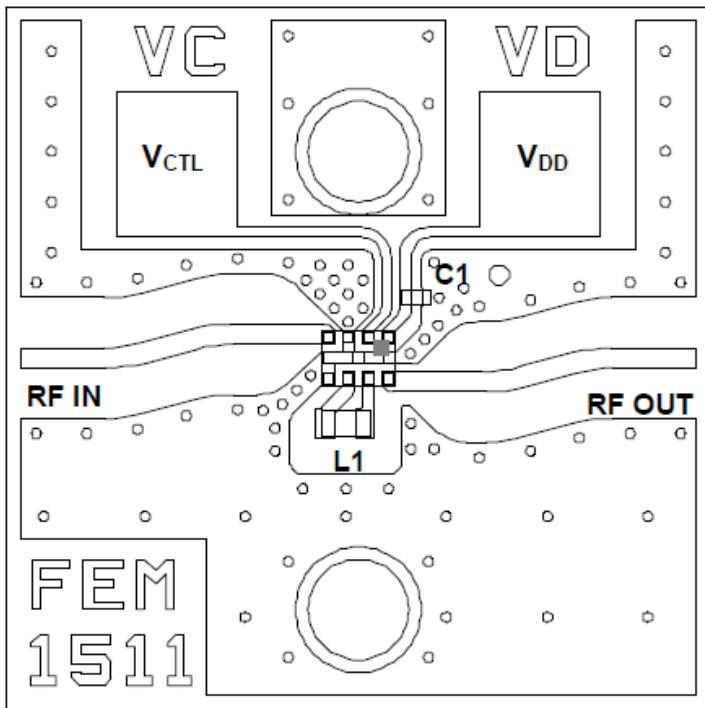

M. EVALUATION BOARD:

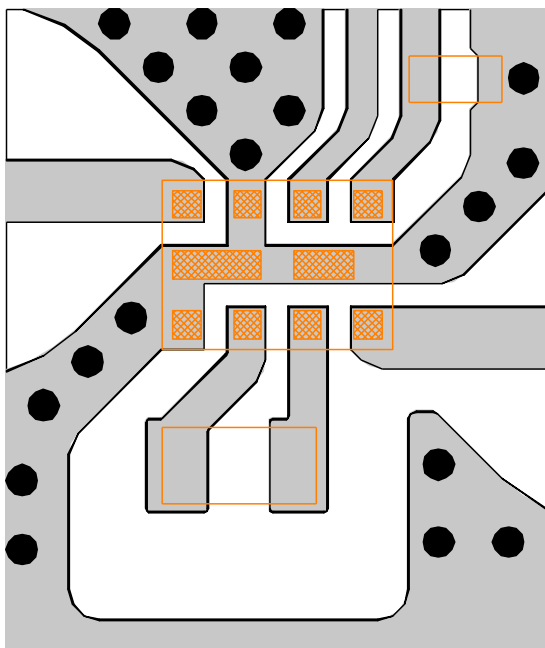

PCB
 Substrate: FR-4
 Thickness: 0.2 mm
 Microstrip line width: 0.4 mm ($Z_0=50 \Omega$)
 Size: 14.0 mm x 14.0 mm

<PCB LAYOUT GUIDELINE>



 PCB
 PKG Terminal
 PKG Outline
 GND Via Hole
 Diameter $\square\square = 0.2 \text{ mm}$

PRECAUTIONS

- Please layout ground pattern under this FEM in order not to couple with RFIN and RFOUT terminal.
- All external parts should be placed as close as possible to the FEM.
- For good RF performance, all GND terminals must be connected to PCB ground plane of substrate, and via-holes for GND should be placed near the FEM.

O. PACKING SPECIFICATION:

【TAPING DIMENSION】

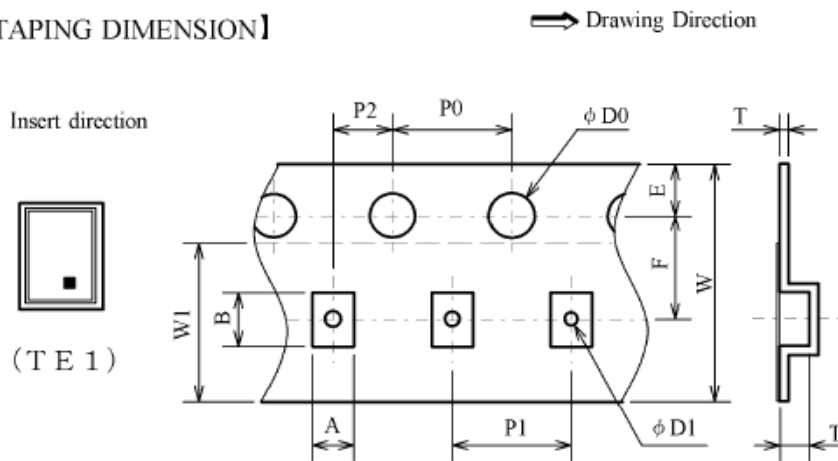

| SYMBOL | DIMENSION | REMARKS |
|--------|------------------------------------|-------------------|
| A | 1.4±0.1 | BOTTOM DIMENSION |
| B | 1.8±0.1 | BOTTOM DIMENSION |
| D0 | 1.5 ^{+0.1} / ₀ | |
| D1 | 0.5±0.05 | |
| E | 1.75±0.1 | |
| F | 3.5±0.05 | |
| P0 | 4.0±0.1 | |
| P1 | 4.0±0.1 | |
| P2 | 2.0±0.05 | |
| T | 0.25±0.05 | |
| T2 | 0.7±0.1 | |
| W | 8.0±0.2 | |
| W1 | 5.3±0.2 | THICKNESS100umMAX |

*Carrier tape material: PS (Anti-static)
Cover tape material: PET (Anti-static)

【REEL DIMENSION】

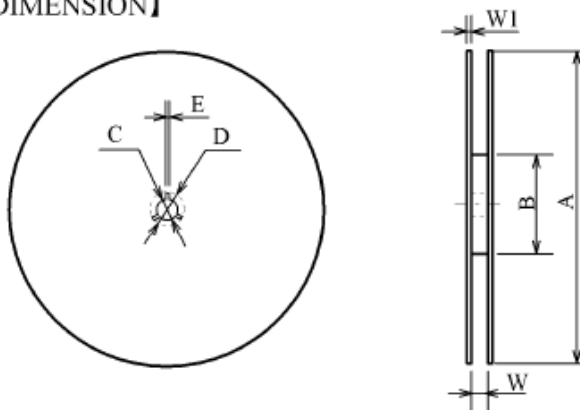

| SYMBOL | DIMENSION |
|--------|---------------------------------------|
| A | φ 180 ⁺⁰ / _{-1.5} |
| B | φ 66±0.5 |
| C | φ 13±0.2 |
| D | φ 21±0.8 |
| E | 2±0.5 |
| W | 9 ^{+1.0} / ₋₀ |
| W1 | 1.2 |

*MATERIAL : PS carbon (Anti-static)

【TAPING STATE】

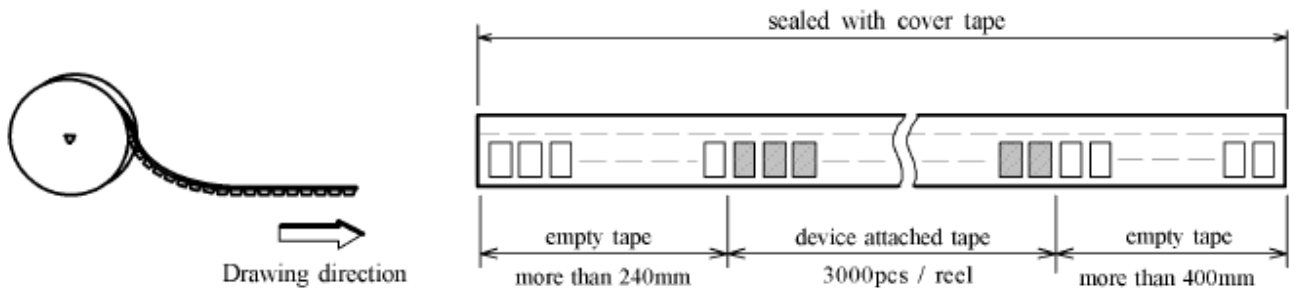

P. RECOMMENDED REFLOW PROFILE:

* Recommended reflow soldering procedure

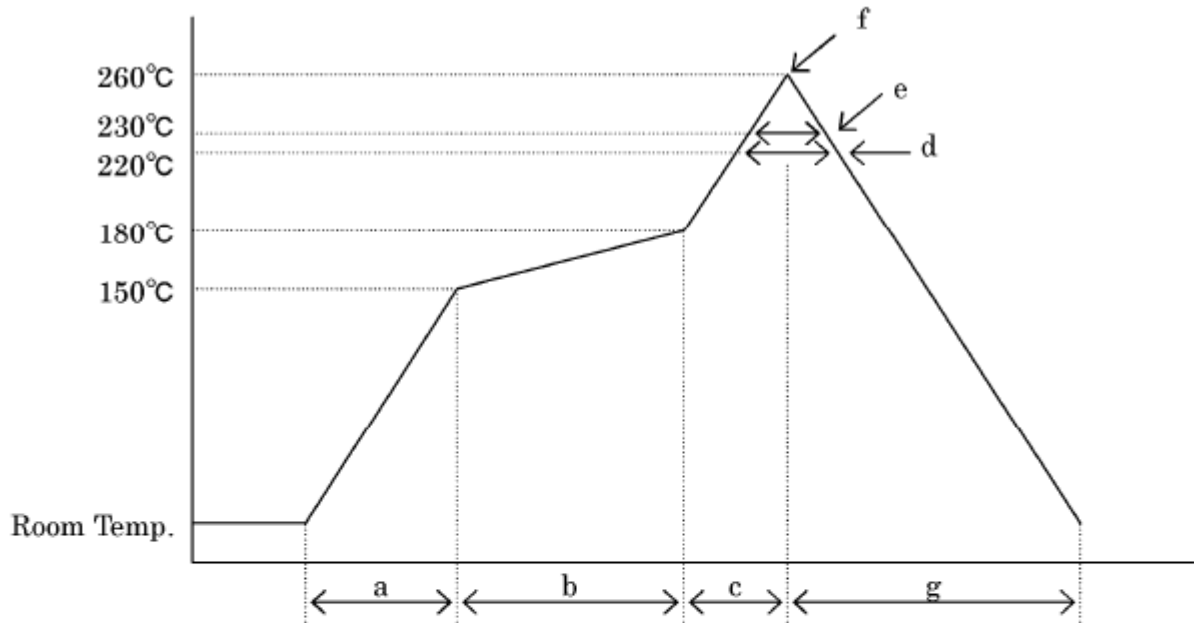

- a: Temperature ramping rate : 1 to 4°C/s
- b: Pre-heating temperature : 150 to 180°C
time : 60 to 120s
- c: Temperature ramp rate : 1 to 4°C/s
- d: 220°C or higher time : Shorter than 60s
- e: 230°C or higher time : Shorter than 40s
- f: Peak temperature : Lower than 260°C
- g: Temperature ramping rate : 1 to 6°C/s

The temperature indicates at the surface of mold package.

Cautions on using this product

This product contains Gallium-Arsenide (GaAs) which is a harmful material.

- Do NOT eat or put into mouth.
- Do NOT dispose in fire or break up this product.
- Do NOT chemically make gas or powder with this product.
- To waste this product, please obey the relating law of your country.

This product may be damaged with electric static discharge (ESD) or spike voltage. Please handle with care to avoid these damages.