

TMP75B-Q1 1.8-V Digital Temperature Sensor with Two-Wire Interface and Alert

1 Features

- Qualified for Automotive Applications
- AEC-Q100 Qualified with the Following Results:
 - Temperature Grade 1: -40°C to 125°C
 - HBM ESD Classification 2
 - CDM ESD Classification C4B
- Digital Output with Two-Wire Serial Interface
- Up to 8 Pin-Programmable Bus Addresses
- Programmable Overtemperature ALERT
- Shutdown Mode for Power Saving
- One-Shot Conversion Mode
- Operating Temperature Range: -40°C to 125°C
- Operating Supply Range: 1.4 V to 3.6 V
- Quiescent Current:
 - 45 μA Active (typ)
 - 0.3 μA Shutdown (typ)
- Accuracy:
 - $\pm 0.5^{\circ}\text{C}$ (typ) from -20°C to 85°C
 - $\pm 1^{\circ}\text{C}$ (typ) from -40°C to 125°C
- Resolution: 12 Bits (0.0625°C)
- Packages: SOIC-8 and VSSOP-8

2 Applications

- Automotive Embedded Systems
- ECU Processor Temperature Monitoring
- TCM Processor Temperature Monitoring
- BCM Processor Temperature Monitoring
- LED Headlight Thermal Control
- Battery Thermal Protection
- Electrical Motor Driver Thermal Protection

3 Description

The TMP75B-Q1 is an integrated digital temperature sensor with a 12-bit analog-to-digital converter (ADC) that can operate at a 1.8-V supply, and is pin and register compatible with the industry-standard LM75 and TMP75. This device is available in SOIC-8 and VSSOP-8 packages, and requires no external components to sense the temperature. The TMP75B-Q1 is capable of reading temperatures with a resolution of 0.0625°C and is specified over a temperature range of -40°C to 125°C .

The TMP75B-Q1 features SMBus and two-wire interface compatibility, and allows up to eight devices on the same bus with the SMBus overtemperature alert function. The programmable temperature limits and the ALERT pin allow the sensor to operate as a stand-alone thermostat, or an overtemperature alarm for power throttling or system shutdown.

The factory-calibrated temperature accuracy and the noise-immune digital interface make the TMP75B-Q1 the preferred solution for temperature compensation of other sensors and electronic components, without the need for additional system-level calibration or elaborate board layout for distributed temperature sensing.

The TMP75B-Q1 is ideal for thermal management and protection of a variety of automotive applications, and is a high-performance alternative to a PCB-mounted NTC thermistor.

Device Information⁽¹⁾

DEVICE NAME	PACKAGE	BODY SIZE (NOM)
TMP75B-Q1	SOIC (8)	4.90 mm x 3.90 mm
	VSSOP (8)	3.00 mm x 3.00 mm

(1) For all available packages, see the package option addendum at the end of the datasheet.

Simplified Schematic

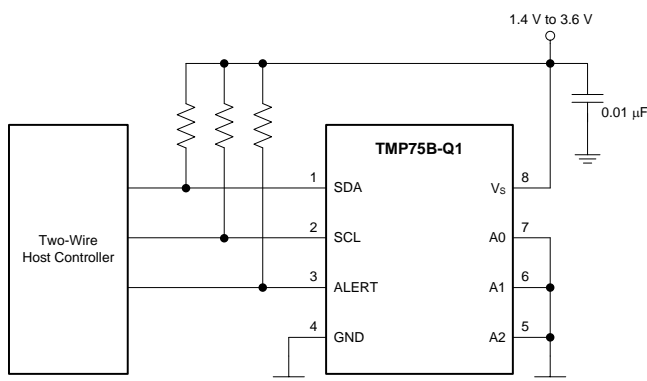

Temperature Accuracy (Error) vs Ambient Temperature

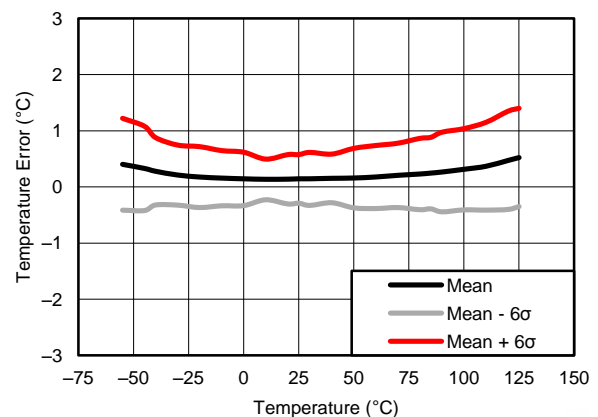

Table of Contents

1 Features	1	7.4 Device Functional Modes.....	15
2 Applications	1	7.5 Programming.....	16
3 Description	1	7.6 Register Map.....	16
4 Revision History	2	8 Application and Implementation	19
5 Pin Configuration and Functions	3	8.1 Application Information.....	19
6 Specifications	4	8.2 Typical Application	19
6.1 Absolute Maximum Ratings	4	9 Power-Supply Recommendations	20
6.2 Handling Ratings.....	4	10 Layout	21
6.3 Recommended Operating Conditions.....	4	10.1 Layout Guidelines	21
6.4 Thermal Information	4	10.2 Layout Example	21
6.5 Electrical Characteristics.....	5	11 Device and Documentation Support	22
6.6 Typical Characteristics.....	6	11.1 Documentation Support	22
7 Detailed Description	7	11.2 Trademarks	22
7.1 Overview	7	11.3 Electrostatic Discharge Caution.....	22
7.2 Functional Block Diagram	7	11.4 Glossary	22
7.3 Feature Description.....	8	12 Mechanical, Packaging, and Orderable Information	22

4 Revision History

DATE	REVISION	NOTES
October 2014	*	Initial release.

5 Pin Configuration and Functions

**D and DGK Packages
SOIC-8 and VSSOP-8
(Top View)**

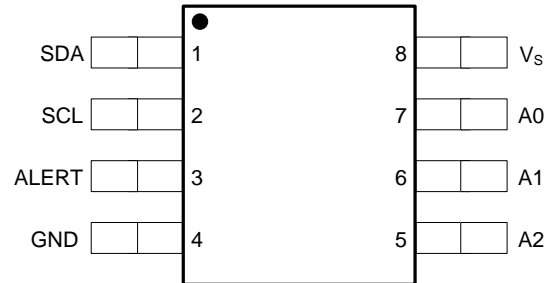

Pin Functions

PIN		I/O	DESCRIPTION
NAME	NO.		
A0	7	I	Address select. Connect to GND or V_S .
A1	6	I	Address select. Connect to GND or V_S .
A2	5	I	Address select. Connect to GND or V_S .
ALERT	3	O	Overtemperature alert. Open-drain output; requires a pull-up resistor.
GND	4	—	Ground
SCL	2	I	Serial clock
SDA	1	I/O	Serial data. Open-drain output; requires a pull-up resistor.
V_S	8	I	Supply voltage, 1.4 V to 3.6 V

6 Specifications

6.1 Absolute Maximum Ratings

over operating free-air temperature range (unless otherwise noted)⁽¹⁾

		MIN	MAX	UNIT
Supply voltage, V_S			4	V
Input voltage	SDA, SCL, ALERT, A2, A1	-0.3	4	V
	A0	-0.3	$(V_S) + 0.3$	V
Sink current	SDA, ALERT		10	mA
Operating junction temperature		-55	150	°C

(1) Stresses beyond those listed under *Absolute Maximum Ratings* may cause permanent damage to the device. These are stress ratings only, which do not imply functional operation of the device at these or any other conditions beyond those indicated under *Recommended Operating Conditions*. Exposure to absolute-maximum-rated conditions for extended periods may affect device reliability.

6.2 Handling Ratings

		MIN	MAX	UNIT		
T_{stg}	Storage temperature range	-60	150	°C		
$V_{(ESD)}$	Electrostatic discharge	Human body model (HBM), per AEC Q100-002 ⁽¹⁾	-2000	2000	V	
		Charged device model (CDM), per AEC Q100-011	Corner pins (1, 4, 5, and 8)	-1000		1000
			Other pins	-1000		1000

(1) AEC Q100-002 indicates HBM stressing is done in accordance with the ANSI/ESDA/JEDEC JS-001 specification.

6.3 Recommended Operating Conditions

over operating free-air temperature range (unless otherwise noted)

		MIN	NOM	MAX	UNIT
Supply voltage		1.4	1.8	3.6	V
Operating free-air temperature, T_A		-40		125	°C

6.4 Thermal Information

THERMAL METRIC ⁽¹⁾		TMP75B-Q1		UNIT
		D (SOIC)	DGK (VSSOP)	
		8 PINS	8 PINS	
$R_{\theta JA}$	Junction-to-ambient thermal resistance	125.4	188.1	°C/W
$R_{\theta JC(top)}$	Junction-to-case (top) thermal resistance	71.5	79.1	
$R_{\theta JB}$	Junction-to-board thermal resistance	65.8	109.6	
Ψ_{JT}	Junction-to-top characterization parameter	21.1	15.3	
Ψ_{JB}	Junction-to-board characterization parameter	65.3	108	
$R_{\theta JC(bot)}$	Junction-to-case (bottom) thermal resistance	N/A	N/A	

(1) For more information about traditional and new thermal metrics, see the *IC Package Thermal Metrics* application report, [SPRA953](http://www.ti.com/lit/zip/Spra953).

6.5 Electrical Characteristics

At $T_A = -40^\circ\text{C}$ to 125°C and $V_S = 1.4\text{ V}$ to 3.6 V , unless otherwise noted. Typical values at $T_A = 25^\circ\text{C}$ and $V_S = 1.8\text{ V}$.

PARAMETER	TEST CONDITIONS	MIN	TYP	MAX	UNIT	
TEMPERATURE INPUT						
Temperature range		-40		125	$^\circ\text{C}$	
Temperature resolution			0.0625		$^\circ\text{C}$	
Temperature accuracy (error)	-20°C to 85°C		± 0.5	± 2	$^\circ\text{C}$	
	-40°C to 125°C		± 1	± 3	$^\circ\text{C}$	
DIGITAL INPUT/OUTPUT						
V_{IH}	High-level input voltage	$0.7(V_S)$		V_S	V	
V_{IL}	Low-level input voltage	-0.3		$0.3(V_S)$	V	
I_{IN}	Input current	$0\text{ V} < V_{IN} < (V_S) + 0.3\text{ V}$		1	μA	
V_{OL}	Low-level output voltage	$V_S \geq 2\text{ V}, I_{OUT} = 3\text{ mA}$		0.4	V	
		$V_S < 2\text{ V}, I_{OUT} = 3\text{ mA}$		$0.2(V_S)$	V	
	ADC resolution		12		Bit	
	Conversion time	One-shot mode	20	27	35	ms
	Conversion modes	CR1 = 0, CR0 = 0 (default)		37	Conv/s	
		CR1 = 0, CR0 = 1		18	Conv/s	
		CR1 = 1, CR0 = 0		9	Conv/s	
		CR1 = 1, CR0 = 1		4	Conv/s	
	Timeout time		38	54	70	ms
POWER SUPPLY						
	Operating supply range		1.4		3.6	V
I_Q	Quiescent current	Serial bus inactive, CR1 = 0, CR0 = 0 (default)		45	89	μA
		Serial bus inactive, CR1 = 0, CR0 = 1		22	48	μA
		Serial bus inactive, CR1 = 1, CR0 = 0		12	30	μA
		Serial bus inactive, CR1 = 1, CR0 = 1		6.5	21	μA
I_{SD}	Shutdown current	Serial bus inactive		0.3	8	μA
		Serial bus active, SCL frequency = 400 kHz		10		μA
		Serial bus active, SCL frequency = 3.4 MHz		80		μA

6.6 Typical Characteristics

At $T_A = 25^\circ\text{C}$ and $V_S = 1.8\text{ V}$ (unless otherwise noted).

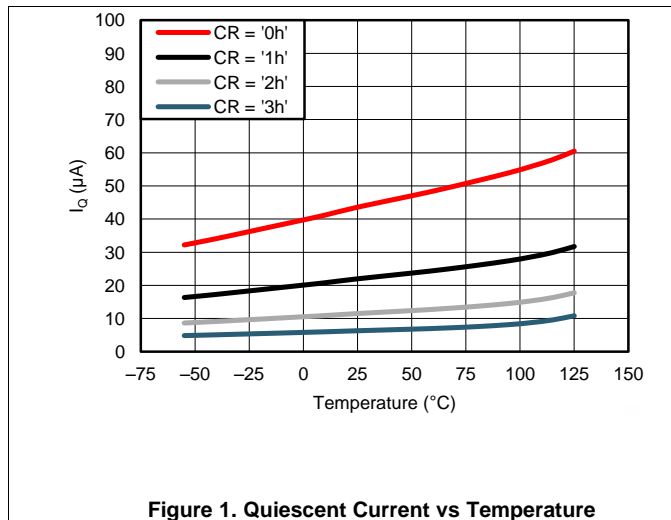

Figure 1. Quiescent Current vs Temperature

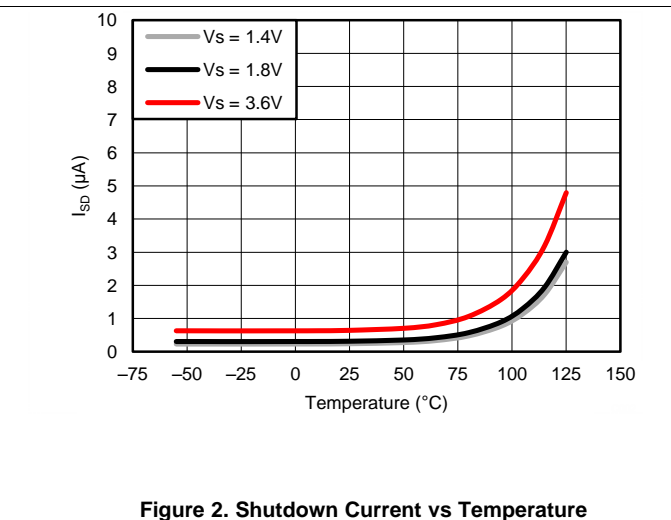

Figure 2. Shutdown Current vs Temperature

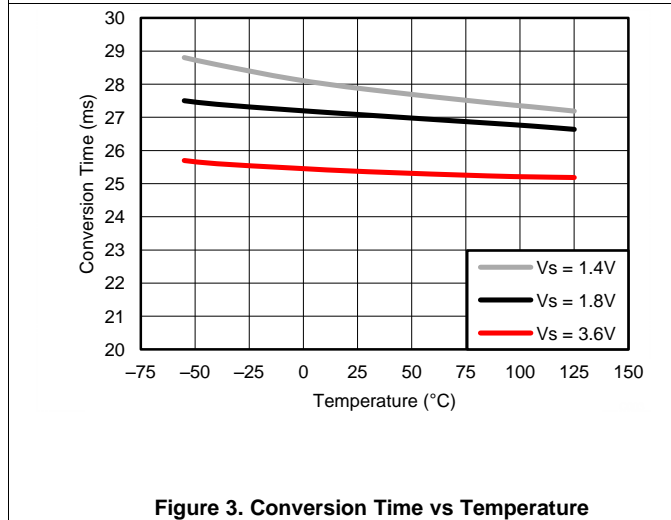

Figure 3. Conversion Time vs Temperature

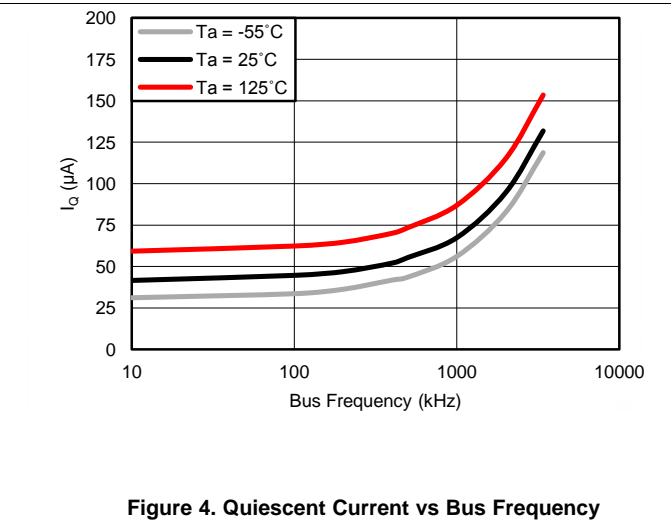

Figure 4. Quiescent Current vs Bus Frequency

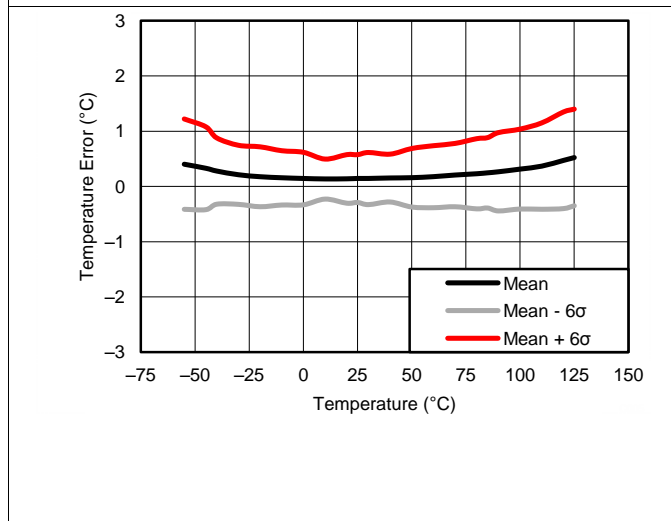

Figure 5. Temperature Error vs Temperature

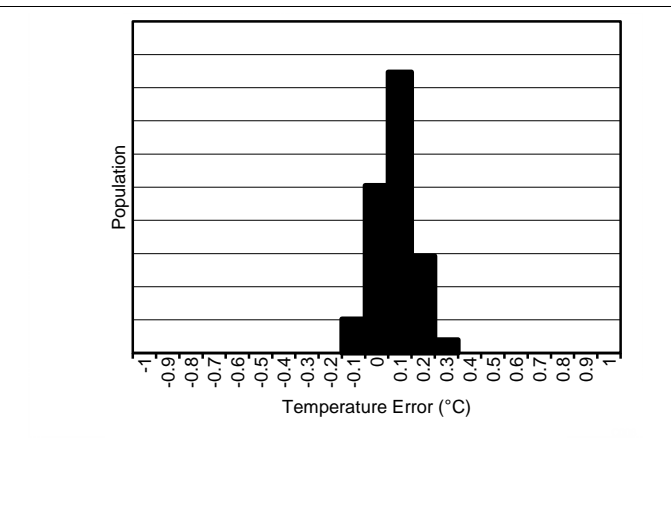

Figure 6. Temperature Error at 25°C

7 Detailed Description

7.1 Overview

The TMP75B-Q1 is a digital temperature sensor optimal for thermal management and thermal protection applications. The TMP75B-Q1 is two-wire and SMBus interface compatible, and is specified over a temperature range of -40°C to 125°C .

The temperature sensing device for the TMP75B-Q1 is the chip itself. A bipolar junction transistor (BJT) inside the chip is used in a band-gap configuration to produce a voltage proportional to the chip temperature. The voltage is digitized and converted to a 12-bit temperature result in degrees Celsius, with a resolution of 0.0625°C . The package leads provide the primary thermal path because of the lower thermal resistance of the metal. Thus, the temperature result is equivalent to the local temperature of the printed circuit board (PCB) where the sensor is mounted.

7.2 Functional Block Diagram

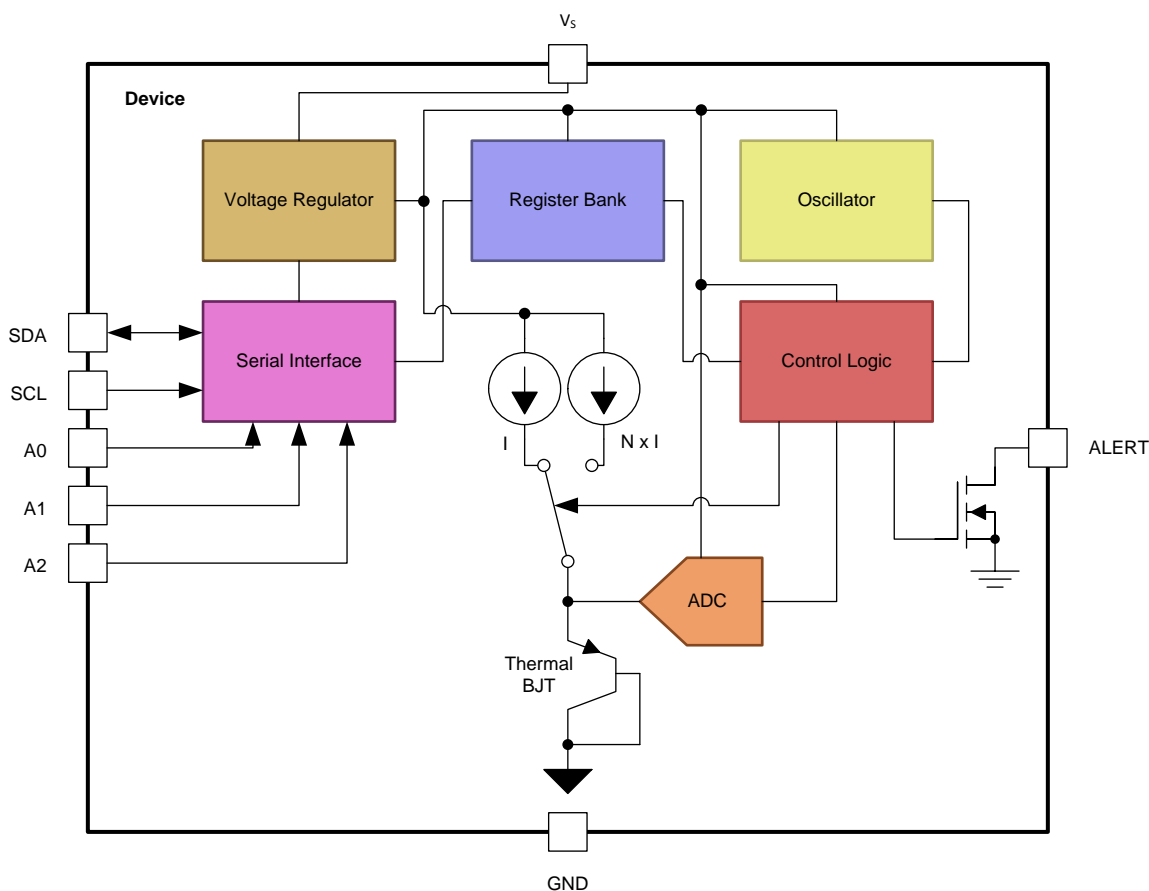

7.3 Feature Description

7.3.1 Digital Temperature Output

The 12-bit digital output from each temperature measurement conversion is stored in the read-only temperature register. Two bytes must be read to obtain the data; see [Figure 15](#). Note that byte 1 is the most significant byte, followed by byte 2, the least significant byte. The temperature result is left-justified with the 12 most significant bits used to indicate the temperature. There is no need to read the second byte if resolution below 1°C is not required. [Table 1](#) summarizes the temperature data format. One LSB equals 0.0625°C. Negative numbers are represented in binary twos complement format.

Table 1. Temperature Data Format⁽¹⁾

TEMPERATURE (°C)	DIGITAL OUTPUT	
	BINARY	HEX
128	0111 1111 1111	7FF
127.9375	0111 1111 1111	7FF
100	0110 0100 0000	640
80	0101 0000 0000	500
75	0100 1011 0000	4B0
50	0011 0010 0000	320
25	0001 1001 0000	190
0.25	0000 0000 0100	004
0	0000 0000 0000	000
-0.25	1111 1111 1100	FFC
-25	1110 0111 0000	E70
-55	1100 1001 0000	C90

(1) The temperature sensor resolution is 0.0625°C/LSB.

[Table 1](#) does not supply a full list of all temperatures. Use the following rules to obtain the digital data format for a given temperature, and vice versa.

To convert positive temperatures to a digital data format:

Divide the temperature by the resolution. Then, convert the result to binary code with a 12-bit, left-justified format, and MSB = 0 to denote a positive sign.

Example: $(50^{\circ}\text{C}) / (0.0625^{\circ}\text{C} / \text{LSB}) = 800 = 320\text{h} = 0011\ 0010\ 0000$

To convert a positive digital data format to temperature:

Convert the 12-bit, left-justified binary temperature result, with the MSB = 0 to denote a positive sign, to a decimal number. Then, multiply the decimal number by the resolution to obtain the positive temperature.

Example: $0011\ 0010\ 0000 = 320\text{h} = 800 \times (0.0625^{\circ}\text{C} / \text{LSB}) = 50^{\circ}\text{C}$

To convert negative temperatures to a digital data format:

Divide the absolute value of the temperature by the resolution, and convert the result to binary code with a 12-bit, left-justified format. Then, generate the twos complement of the result by complementing the binary number and adding one. Denote a negative number with MSB = 1.

Example: $(|-25^{\circ}\text{C}|) / (0.0625^{\circ}\text{C} / \text{LSB}) = 400 = 190\text{h} = 0001\ 1001\ 0000$

Two's complement format: $1110\ 0110\ 1111 + 1 = 1110\ 0111\ 0000$

To convert a negative digital data format to temperature:

Generate the twos complement of the 12-bit, left-justified binary number of the temperature result (with MSB = 1, denoting negative temperature result) by complementing the binary number and adding one. This represents the binary number of the absolute value of the temperature. Convert to decimal number and multiply by the resolution to get the absolute temperature, then multiply by -1 for the negative sign.

Example: $1110\ 0111\ 0000$ has twos complement of $0001\ 1001\ 0000 = 0001\ 1000\ 1111 + 1$

Convert to temperature: $0001\ 1001\ 0000 = 190\text{h} = 400$; $400 \times (0.0625^{\circ}\text{C} / \text{LSB}) = 25^{\circ}\text{C} = (|-25^{\circ}\text{C}|)$; $(|-25^{\circ}\text{C}|) \times (-1) = -25^{\circ}\text{C}$

7.3.2 Temperature Limits and Alert

The temperature limits are stored in the T_{LOW} and T_{HIGH} registers (Table 8 and Table 9) in the same format as the temperature result, and their values are compared to the temperature result on every conversion. The outcome of the comparison drives the behavior of the ALERT pin, which can operate as a comparator output or an interrupt, and is set by the TM bit in the configuration register (Table 7).

In comparator mode (TM = 0, default), the ALERT pin becomes active when the temperature is equal to or exceeds the value in T_{HIGH} (fault conditions) for a consecutive number of conversions as set by the FQ bits of the configuration register. ALERT clears when the temperature falls below T_{LOW} for the same consecutive number of conversions. The difference between the two limits acts as a hysteresis on the comparator output, and a fault counter prevents false alerts as a result of environmental noise.

In interrupt mode (TM = 1), the ALERT pin becomes active when the temperature equals or exceeds the value in T_{HIGH} for a consecutive number of fault conditions. The ALERT pin remains active until a read operation of any register occurs, or the device successfully responds to the SMBus alert response address. The ALERT pin is also cleared if the device is placed in shutdown mode (see the *Shutdown Mode* section for shutdown mode description). After the ALERT pin is cleared, this pin becomes active again only when the temperature falls below T_{LOW} for a consecutive number of fault conditions, and remains active until cleared by a read operation of any register, or a successful response to the SMBus alert response address. After the ALERT pin is cleared, the cycle repeats with the ALERT pin becoming active when the temperature equals or exceeds T_{HIGH} , and so on. The ALERT pin can also be cleared by resetting the device with the general-call reset command. This action also clears the state of the internal registers in the device and the fault counter memory, returning the device to comparator mode (TM = 0).

The active state of the ALERT pin is set by the POL bit in the configuration register. When POL = 0 (default), the ALERT pin is active low. When POL = 1, the ALERT pin is active high. The operation of the ALERT pin in various modes is shown in Figure 7.

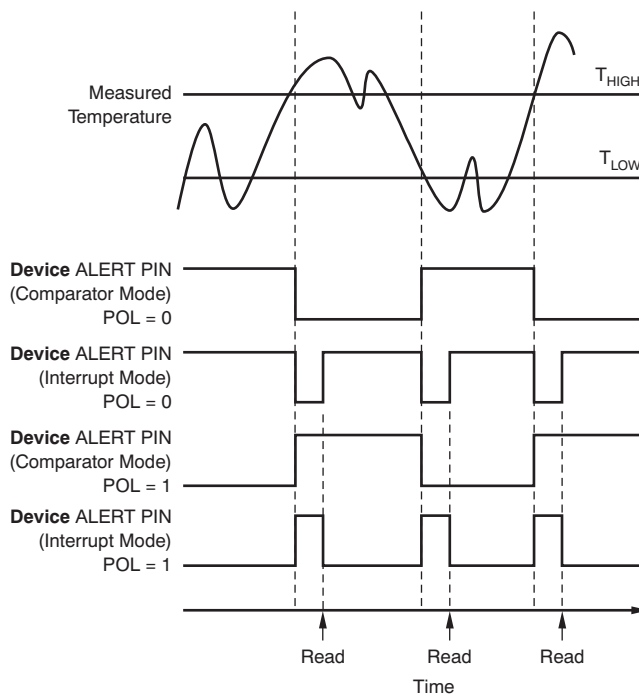

Figure 7. ALERT Pin Modes of Operation

7.3.3 Serial Interface

The TMP75B-Q1 operates as a slave device only on the two-wire bus and SMBus. Connections to the bus are made using the open-drain I/O lines, SDA and SCL. The SDA and SCL pins feature integrated spike-suppression filters and Schmitt triggers to minimize the effects of input spikes and bus noise. The TMP75B-Q1 supports the transmission protocol for both fast (1 kHz to 400 kHz) and high-speed (1 kHz to 3 MHz) modes. All data bytes are transmitted MSB first.

7.3.3.1 Bus Overview

The device that initiates the transfer is called a *master*, and the devices controlled by the master are *slaves*. The bus must be controlled by a master device that generates the serial clock (SCL), controls the bus access, and generates the start and stop conditions.

To address a specific device, initiate a start condition by pulling the data line (SDA) from a high to a low logic level while SCL is high. All slaves on the bus shift in the slave address byte; the last bit indicates whether a read or write operation follows. During the ninth clock pulse, the slave being addressed responds to the master by generating an acknowledge bit and pulling SDA low.

Data transfer is then initiated and sent over eight clock pulses followed by an acknowledge bit. During data transfer, SDA must remain stable while SCL is high because any change in SDA while SCL is high is interpreted as a start or stop signal.

After all data have been transferred, the master generates a stop condition indicated by pulling SDA from low to high, while SCL is high.

7.3.3.2 Serial Bus Address

To communicate with the TMP75B-Q1, the master must first communicate with slave devices using a slave address byte. The slave address byte consists of seven address bits, and a direction bit indicating the intent of executing either a read or write operation. The TMP75B-Q1 features three address pins that allow up to eight devices to be addressed on a single bus. The TMP75B-Q1 latches the status of the address pins at the start of a communication. [Table 2](#) describes the pin logic levels and the corresponding address values.

Table 2. Address Pin Connections and Slave Addresses

DEVICE TWO-WIRE ADDRESS	A2	A1	A0
1001000	GND	GND	GND
1001001	GND	GND	V _S
1001010	GND	V _S	GND
1001011	GND	V _S	V _S
1001100	V _S	GND	GND
1001101	V _S	GND	V _S
1001110	V _S	V _S	GND
1001111	V _S	V _S	V _S

7.3.3.3 Writing and Reading Operation

Accessing a particular register on the TMP75B-Q1 is accomplished by writing the appropriate value to the pointer register. The value for the pointer register is the first byte transferred after the slave address byte with the R/W bit low. Every write operation to the TMP75B-Q1 requires a value for the pointer register (see [Figure 9](#)).

When reading from the TMP75B-Q1, the last value stored in the pointer register by a write operation is used to determine which register is read by a read operation. To change the register pointer for a read operation, a new value must be written to the pointer register. This action is accomplished by issuing a slave address byte with the R/W bit low, followed by the pointer register byte. No additional data are required. The master can then generate a start condition and send the slave address byte with the R/W bit high to initiate the read command. See [Figure 10](#) for details of this sequence. If repeated reads from the same register are desired, there is no need to continually send the pointer register bytes because the TMP75B-Q1 stores the pointer register value until it is changed by the next write operation.

Note that register bytes are sent with the most significant byte first, followed by the least significant byte.

7.3.3.4 Slave-Mode Operations

The TMP75B-Q1 can operate as a slave receiver or slave transmitter.

7.3.3.4.1 Slave Receiver Mode:

The first byte transmitted by the master is the slave address, with the R/W bit low. The TMP75B-Q1 then acknowledges reception of a valid address. The next byte transmitted by the master is the pointer register. The TMP75B-Q1 then acknowledges reception of the pointer register byte. The next byte or bytes are written to the register addressed by the pointer register. The TMP75B-Q1 acknowledges reception of each data byte. The master can terminate data transfer by generating a start or stop condition.

7.3.3.4.2 Slave Transmitter Mode:

The first byte transmitted by the master is the slave address, with the R/W bit high. The slave acknowledges reception of a valid slave address. The next byte is transmitted by the slave and is the most significant byte of the register indicated by the pointer register. The master acknowledges reception of the data byte. The next byte transmitted by the slave is the least significant byte. The master acknowledges reception of the data byte. The master can terminate data transfer by generating a not-acknowledge bit on reception of any data byte, or by generating a start or stop condition.

7.3.3.5 SMBus Alert Function

The TMP75B-Q1 supports the SMBus alert function. When the TMP75B-Q1 operates in interrupt mode ($TM = 1$), the ALERT pin may be connected as an SMBus alert signal. When a master senses that an alert condition is present on the ALERT line, the master sends an SMBus alert command (00011001) to the bus. If the ALERT pin is active, the device acknowledges the SMBus alert command and responds by returning its slave address on the SDA line. The eighth bit (LSB) of the slave address byte indicates whether the alert condition is caused by the temperature exceeding T_{HIGH} or falling below T_{LOW} . The LSB is high if the temperature is greater than T_{HIGH} , or low if the temperature is less than T_{LOW} . See [Figure 11](#) for details of this sequence.

If multiple devices on the bus respond to the SMBus alert command, arbitration during the slave address portion of the SMBus alert command determines which device clears its alert status first. If the TMP75B-Q1 wins the arbitration, its ALERT pin becomes inactive at the completion of the SMBus alert command. If the TMP75B-Q1 loses the arbitration, its ALERT pin remains active.

7.3.3.6 General Call

The TMP75B-Q1 responds to a two-wire general call address (0000000) if the eighth bit is 0. The device acknowledges the general call address and responds to commands in the second byte. If the second byte is 00000100, the TMP75B-Q1 latches the status of the address pin, but does not reset. If the second byte is 00000110, the TMP75B-Q1 internal registers are reset to power-up values.

7.3.3.7 High-Speed (Hs) Mode

In order for the two-wire bus to operate at frequencies above 400 kHz, the master device must issue an SMBus Hs-mode master code (00001xxx) as the first byte after a start condition to switch the bus to high-speed operation. The TMP75B-Q1 does not acknowledge this byte, but does switch its input filters on SDA and SCL and its output filters on SDA to operate in Hs-mode, allowing transfers at up to 3 MHz. After the Hs-mode master code has been issued, the master transmits a two-wire slave address to initiate a data-transfer operation. The bus continues to operate in Hs-mode until a stop condition occurs on the bus. Upon receiving the stop condition, the TMP75B-Q1 switches the input and output filters back to fast-mode operation.

7.3.3.8 Timeout Function

The TMP75B-Q1 resets the serial interface if SCL or SDA are held low for 54 ms (typ) between a start and stop condition. If the TMP75B-Q1 is pulled low, it releases the bus and then waits for a start condition. To avoid activating the timeout function, it is necessary to maintain a communication speed of at least 1 kHz for the SCL operating frequency.

7.3.3.9 Two-Wire Timing

The TMP75B-Q1 is two-wire and SMBus compatible. [Figure 8](#) to [Figure 11](#) describe the various operations on the TMP75B-Q1. Parameters for [Figure 8](#) are defined in [Table 3](#). Bus definitions are:

Bus Idle Both SDA and SCL lines remain high.

Start Data Transfer A change in the state of the SDA line, from high to low, while the SCL line is high defines a start condition. Each data transfer is initiated with a start condition.

Stop Data Transfer A change in the state of the SDA line from low to high while the SCL line is high defines a stop condition. Each data transfer is terminated with a repeated start or stop condition.

Data Transfer The number of data bytes transferred between a start and a stop condition is not limited, and is determined by the master device.

The receiver acknowledges the transfer of data. It is also possible to use the TMP75B-Q1 for single-byte updates. To update only the MS byte, terminate communication by issuing a start or stop condition on the bus.

Acknowledge Each receiving device, when addressed, must generate an acknowledge bit.

A device that acknowledges must pull down the SDA line during the acknowledge clock pulse so that the SDA line is stable low during the high period of the acknowledge clock pulse. Setup and hold times must be taken into account. When a master receives data, the termination of the data transfer can be signaled by the master generating a *not-acknowledge* (1) on the last byte transmitted by the slave.

Table 3. Timing Diagram Requirements

PARAMETER		FAST MODE		HIGH-SPEED MODE		UNIT	
		MIN	MAX	MIN	MAX		
$f_{(SCL)}$	SCL operating frequency	$V_S \geq 1.8\text{ V}$	0.001	0.4	0.001	3	MHz
		$V_S < 1.8\text{ V}$	0.001	0.4	0.001	2.5	MHz
$t_{(BUF)}$	Bus free time between stop and start conditions	$V_S \geq 1.8\text{ V}$	1300		160		ns
		$V_S < 1.8\text{ V}$	1300		260		ns
$t_{(HDSTA)}$	Hold time after repeated start condition. After this period, the first clock is generated.		600		160		ns
$t_{(SUSTA)}$	Repeated start condition setup time		600		160		ns
$t_{(SUSTO)}$	Stop condition setup time		600		160		ns
$t_{(HDDAT)}$	Data hold time	$V_S \geq 1.8\text{ V}$	0	900	0	100	ns
		$V_S < 1.8\text{ V}$	0	900	0	140	ns
$t_{(SUDAT)}$	Data setup time	$V_S \geq 1.8\text{ V}$	100		10		ns
		$V_S < 1.8\text{ V}$	100		20		ns
$t_{(LOW)}$	SCL clock low period	$V_S \geq 1.8\text{ V}$	1300		190		ns
		$V_S < 1.8\text{ V}$	1300		240		ns
$t_{(HIGH)}$	SCL clock high period		600		60		ns
$t_{R(SDA)}, t_{F(SDA)}$	Data rise and fall time			300		80	ns
$t_{R(SCL)}, t_{F(SCL)}$	Clock rise and fall time			300		40	ns
t_R	Clock and data rise time for $SCLK \leq 100\text{ kHz}$			1000			ns

7.3.3.10 Two-Wire Timing Diagrams

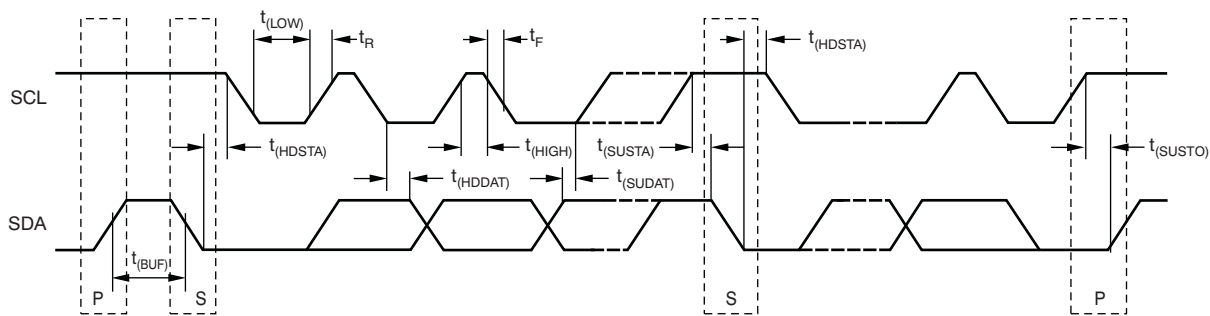
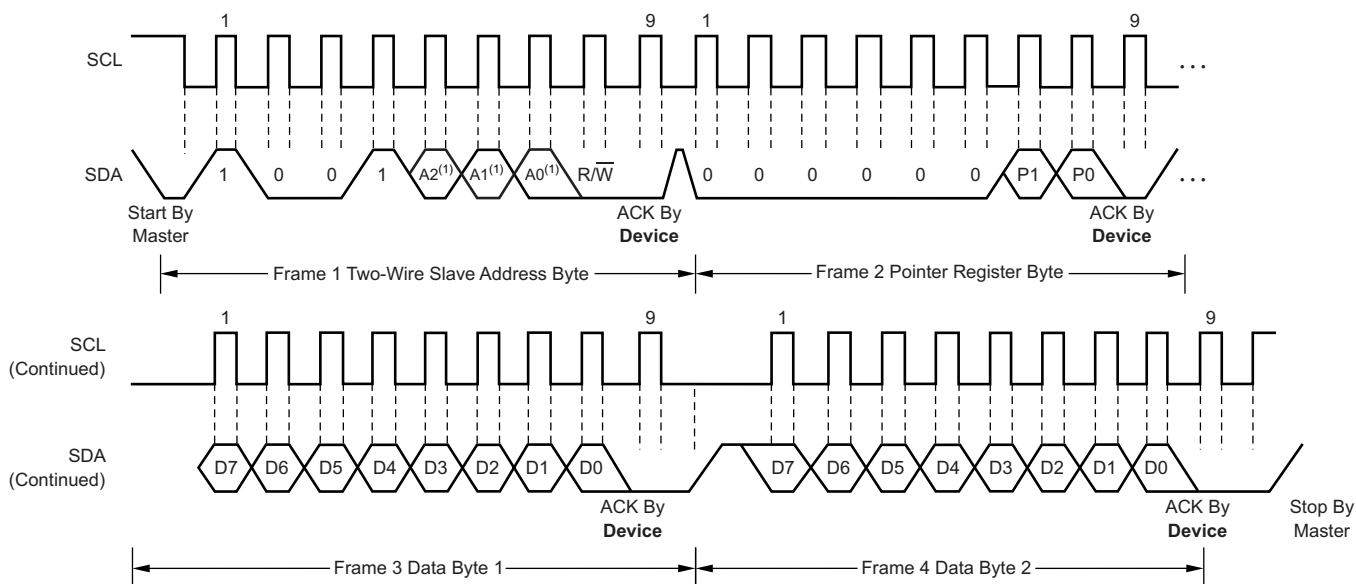
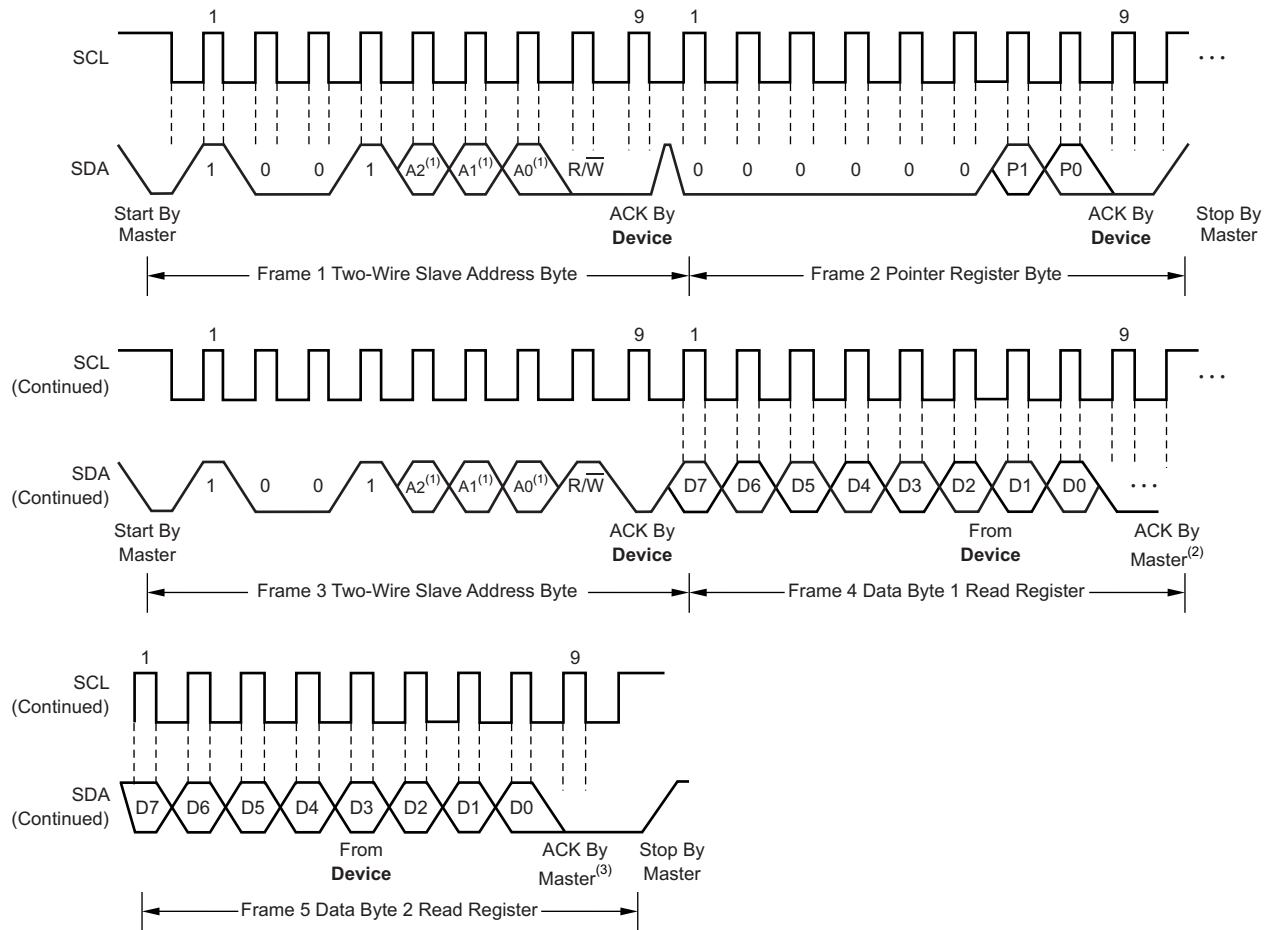

Figure 8. Two-Wire Timing Diagram



(1) The value of A0, A1, and A2 are determined by the connections of the corresponding pins.

Figure 9. Two-Wire Timing Diagram for Write Word Format



- (1) The value of A_0 , A_1 , and A_2 are determined by the connections of the corresponding pins.
- (2) Master should leave SDA high to terminate a single-byte read operation.
- (3) Master should leave SDA high to terminate a two-byte read operation.

Figure 10. Two-Wire Timing Diagram for Read Word Format

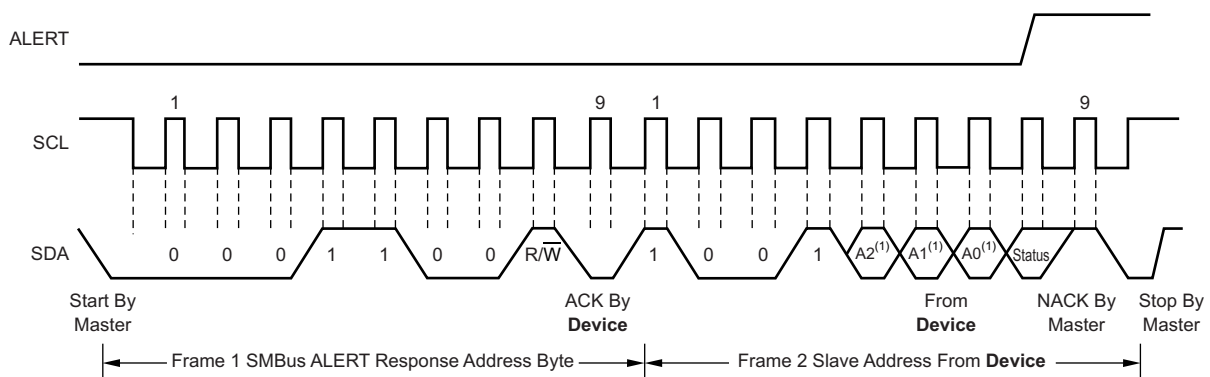

- (1) The value of A_0 , A_1 , and A_2 are determined by the connections of the corresponding pins.

Figure 11. Timing Diagram for SMBus Alert

7.4 Device Functional Modes

7.4.1 Continuous-Conversion Mode

The default mode of the TMP75B-Q1 is continuous conversion, where the ADC performs continuous temperature conversions and stores each result to the temperature register, overwriting the result from the previous conversion. Conversion rate bits CR1 and CR0 in the configuration register configure the TMP75B-Q1 for typical conversion rates of 37 Hz, 18 Hz, 9 Hz, or 4 Hz. The TMP75B-Q1 has a typical conversion time of 27 ms. To achieve different conversion rates, the TMP75B-Q1 makes a conversion, and then powers down and waits for the appropriate delay set by CR1 and CR0. The default rate is 37 Hz (no delay between conversions). Table 4 shows the settings for CR1 and CR0.

Table 4. Conversion Rate Settings

CR1	CR0	CONVERSION RATE (TYP)	I _q (TYP)
0	0	37 Hz (continuous conversion, default)	45 μ A
0	1	18 Hz	22 μ A
1	0	9 Hz	12 μ A
1	1	4 Hz	6.5 μ A

After power-up or a general-call reset, the TMP75B-Q1 immediately starts a conversion, as shown in Figure 12. The first result is available after 27 ms (typical). The active quiescent current during conversion is 45 μ A (typical at 25°C). The quiescent current during delay is 1 μ A (typical at 25°C).

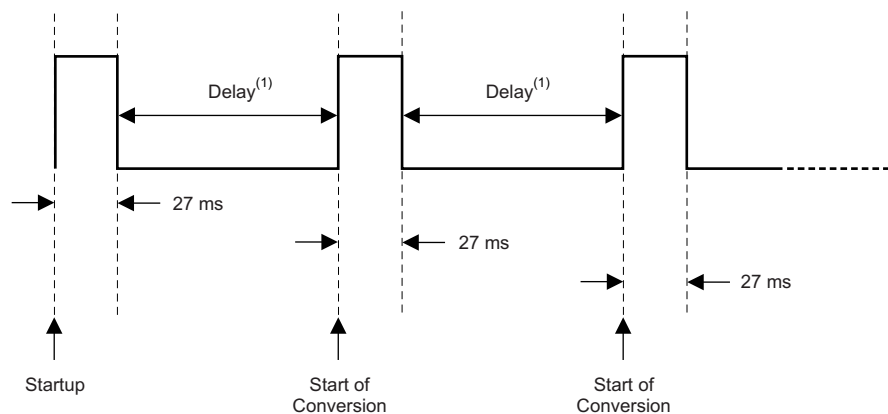

(1) Delay is set by the CR bits in the configuration register.

Figure 12. Conversion Start

7.4.2 Shutdown Mode

Shutdown mode saves maximum power by shutting down all device circuitry other than the serial interface, and reduces current consumption to typically less than 0.3 μ A. Shutdown mode is enabled when the SD bit in the configuration register is set to 1; the device shuts down after the current conversion is completed. When SD is equal to 0, the device operates in continuous-conversion mode. When shutdown mode is enabled, the ALERT pin and fault counter clear in both comparator and interrupt modes; however, this clearing occurs with the rising edge of the shutdown signal. After shutdown is enabled, reprogramming shutdown does not clear the ALERT pin and the fault counter until a rising edge is generated on the shutdown signal.

7.4.3 One-Shot Mode

The TMP75B-Q1 features a *one-shot* temperature measurement mode. When the device is in shutdown mode, writing a 1 to the OS bit starts a single temperature conversion. The device returns to the shutdown state at the completion of the single conversion. This mode reduces power consumption in the TMP75B-Q1 when continuous temperature monitoring is not required. When the configuration register is read, the OS bit always reads zero.

7.5 Programming

Figure 13 shows the internal register structure of the TMP75B-Q1. Use the 8-bit pointer register to address a given data register. The pointer register uses the two LSBs to identify which of the data registers respond to a read or write command. Figure 14 identifies the bits of the pointer register byte.

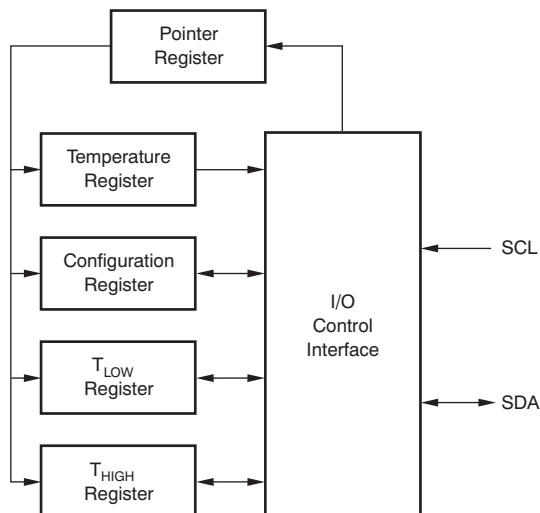

Figure 13. Internal Register Structure

7.6 Register Map

Table 5 describes the registers available in the TMP75B-Q1 with their pointer addresses, followed by the description of the bits in each register.

Table 5. Register Map and Pointer Addresses

P1	P0	REGISTER
0	0	Temperature register (read only, default)
0	1	Configuration register (read/write)
1	0	T _{LOW} register (read/write)
1	1	T _{HIGH} register (read/write)

Figure 14. Pointer Register (pointer = N/A) [reset = 00h]

7	6	5	4	3	2	1	0
Reserved						P1	P0
W-0h						W-0h	W-0h

LEGEND: R/W = Read/Write; R = Read only; W = Write only; -n = value after reset

Figure 15. Temperature Register (pointer = 0h) [reset = 0000h]

15	14	13	12	11	10	9	8
T11	T10	T9	T8	T7	T6	T5	T4
R-0h							
7	6	5	4	3	2	1	0
T3	T2	T1	T0	Reserved			
R-0h				R-0h			

LEGEND: R/W = Read/Write; R = Read only; -n = value after reset

Table 6. Temperature Register Description

Name	Description
T11 to T4	The 8 MSBs of the temperature result (resolution of 1°C)
T3 to T0	The 4 LSBs of the temperature result (resolution of 0.0625°C)

Figure 16. Configuration Register (pointer = 1h) [reset = 00FFh]

15	14	13	12	11	10	9	8
OS	CR		FQ		POL	TM	SD
R/W-0h	R/W-0h		R/W-0h		R/W-0h	R/W-0h	R/W-0h
7	6	5	4	3	2	1	0
Reserved							
R-FFh							

LEGEND: R/W = Read/Write; R = Read only; -n = value after reset

Table 7. Configuration Register Description

Name	Description
OS	One-shot mode In shutdown (SD = 1), write 1 to start a conversion. OS always reads back 0.
CR	Conversion rate control CR = 0h: 37-Hz conversion rate (typ) (default) CR = 1h: 18-Hz conversion rate (typ) CR = 2h: 9-Hz conversion rate (typ) CR = 3h: 4-Hz conversion rate (typ)
FQ	Fault queue to trigger the ALERT pin FQ = 0h: 1 fault (default) FQ = 1h: 2 faults FQ = 2h: 4 faults FQ = 3h: 6 faults
POL	ALERT polarity control POL = 0: ALERT is active low (default) POL = 1: ALERT is active high
TM	ALERT thermostat mode control TM = 0: ALERT is in comparator mode (default) TM = 1: ALERT is in interrupt mode
SD	Shutdown control bit SD = 0: Device is in continuous conversion mode (default) SD = 1: Device is in shutdown mode

Figure 17. T_{LOW}: Temperature Low Limit Register (pointer = 2h) [reset = 4B00h]⁽¹⁾

15	14	13	12	11	10	9	8
L11	L10	L9	L8	L7	L6	L5	L4
R/W-4Bh							
7	6	5	4	3	2	1	0
L3	L2	L1	L0	Reserved			
R/W-0h				R-0h			

LEGEND: R/W = Read/Write; R = Read only; -n = value after reset

(1) 4B00h = 75°C.

Table 8. T_{LOW} Register Description

Name	Description
L11 to L4	The 8 MSBs of the temperature low limit (resolution of 1°C)
L3 to L0	The 4 LSBs of the temperature low limit (resolution of 0.0625°C)

Figure 18. T_{HIGH}: Temperature High Limit Register (pointer = 3h) [reset = 5000h]⁽¹⁾

15	14	13	12	11	10	9	8
H11	H10	H9	H8	H7	H6	H5	H4
R/W-50h							
7	6	5	4	3	2	1	0
H3	H2	H1	H0	Reserved			
R/W-0h				R-0h			

LEGEND: R/W = Read/Write; R = Read only; -n = value after reset

(1) 5000h = 80°C.

Table 9. T_{HIGH} Register Description

Name	Description
H11 to H4	The 8 MSBs of the temperature high limit (resolution of 1°C)
H3 to H0	The 4 LSBs of the temperature high limit (resolution of 0.0625°C)

8 Application and Implementation

NOTE

Information in the following applications sections is not part of the TI component specification, and TI does not warrant its accuracy or completeness. TI's customers are responsible for determining suitability of components for their purposes. Customers should validate and test their design implementation to confirm system functionality.

8.1 Application Information

The TMP75B-Q1 is used to measure the PCB temperature of the location it is mounted. The programmable address options allow up to eight locations on the board to be monitored on a single serial bus. Connecting the ALERT pins together and programming the temperature limit registers to desired values allows for a temperature watchdog operation of all devices, interrupting the host controller only if the temperature exceeds the limits.

8.2 Typical Application

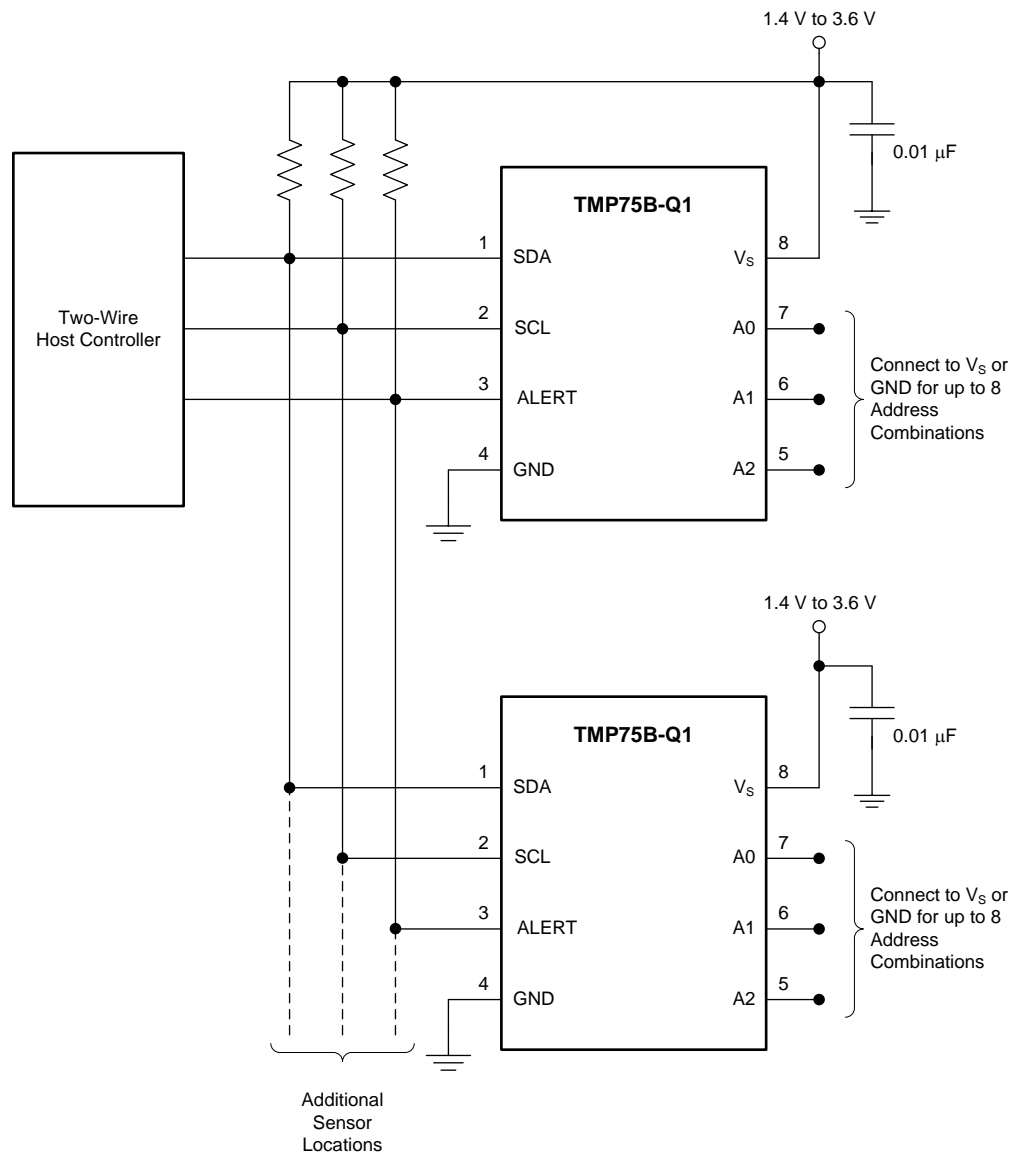

Figure 19. Temperature Monitoring of Multiple Locations on a PCB

Typical Application (continued)

8.2.1 Design Requirements

The TMP75B-Q1 only requires pull-up resistors on SDA and ALERT, although a pull-up resistor is typically present on the SCL as well. A 0.01- μ F bypass capacitor on the supply is recommended, as shown in [Figure 19](#). The SCL, SDA, and ALERT lines can be pulled up to a supply that is equal to or higher than V_S through the pull-up resistors. To configure one of eight different addresses on the bus, connect A0, A1, and A2 to either V_S or GND.

8.2.2 Detailed Design Procedure

The TMP75B-Q1 should be placed in close proximity to the heat source to be monitored, with a proper layout for good thermal coupling. This ensures that temperature changes are captured within the shortest possible time interval.

8.2.3 Application Curve

[Figure 20](#) shows the step response of the TMP75B-Q1 to a submersion in an oil bath of 100°C from room temperature (27°C). The time-constant, or the time for the output to reach 63% of the input step, is 1.5 seconds.

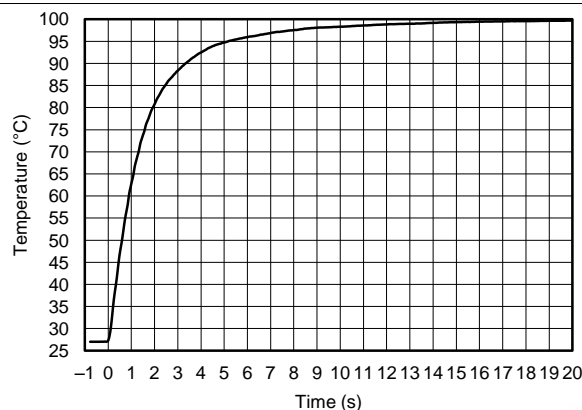

Figure 20. Temperature Step Response

9 Power-Supply Recommendations

The TMP75B-Q1 operates with power supply in the range of 1.4 V to 3.6 V. It is optimized for operation at 1.8-V supply but can measure temperature accurately in the full supply range.

A power-supply bypass capacitor is recommended; place this capacitor as close as possible to the supply and ground pins of the device. A typical value for this supply bypass capacitor is 0.01 μ F. Applications with noisy or high-impedance power supplies may require additional decoupling capacitors to reject power-supply noise.

10 Layout

10.1 Layout Guidelines

Place the temperature sensor as close as possible and run copper planes on the ground or other layers to ensure good thermal coupling to the heat source for fast settling and accurate measurement of the temperature of the hot spot.

Place the power-supply bypass capacitor as close as possible to the supply and ground pins.

Pull up the open-drain output pins (SDA and ALERT) to a supply voltage rail (V_S or higher but up to 3.6 V) through 10-k Ω pull-up resistors. Smaller values of the resistors can be used to compensate for long bus traces that can cause an increase in capacitance and slow rise time for the open-drain outputs; the values should not be less than 1k Ω to avoid self-heating effects due to increased current through the part in the low states of the outputs.

10.2 Layout Example

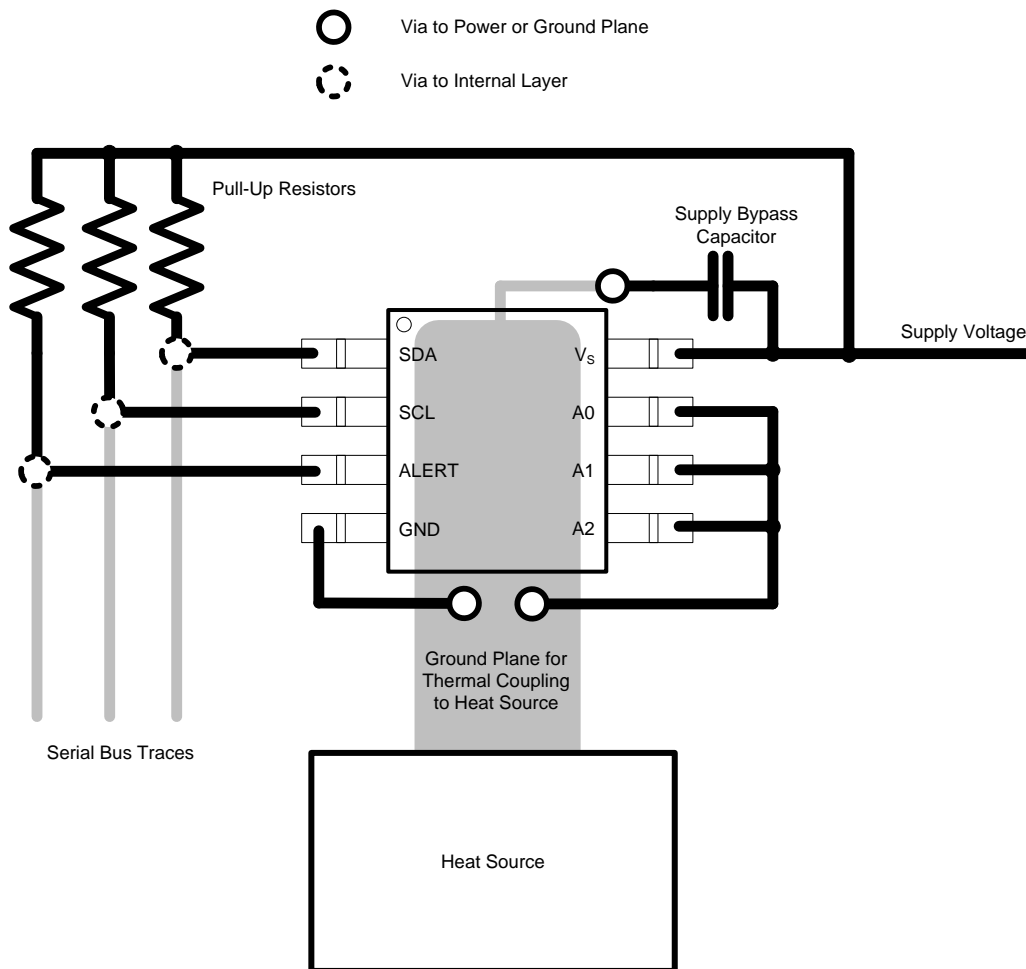

Figure 21. Layout Example

11 Device and Documentation Support

11.1 Documentation Support

11.1.1 Related Documentation

[SBOU141](#) — TMP75xEVM User's Guide

11.2 Trademarks

All trademarks are the property of their respective owners.

11.3 Electrostatic Discharge Caution



This integrated circuit can be damaged by ESD. Texas Instruments recommends that all integrated circuits be handled with appropriate precautions. Failure to observe proper handling and installation procedures can cause damage.

ESD damage can range from subtle performance degradation to complete device failure. Precision integrated circuits may be more susceptible to damage because very small parametric changes could cause the device not to meet its published specifications.

11.4 Glossary

[SLYZ022](#) — *TI Glossary*.

This glossary lists and explains terms, acronyms, and definitions.

12 Mechanical, Packaging, and Orderable Information

The following pages include mechanical, packaging, and orderable information. This information is the most current data available for the designated devices. This data is subject to change without notice and revision of this document. For browser-based versions of this data sheet, refer to the left-hand navigation.

PACKAGING INFORMATION

Orderable Device	Status (1)	Package Type	Package Drawing	Pins	Package Qty	Eco Plan (2)	Lead/Ball Finish (6)	MSL Peak Temp (3)	Op Temp (°C)	Device Marking (4/5)	Samples
TMP75BQDGKRQ1	ACTIVE	VSSOP	DGK	8	2500	Green (RoHS & no Sb/Br)	CU NIPDAUAG	Level-2-260C-1 YEAR	-40 to 125	T75BQ	Samples
TMP75BQDGKTQ1	ACTIVE	VSSOP	DGK	8	250	Green (RoHS & no Sb/Br)	CU NIPDAUAG	Level-2-260C-1 YEAR	-40 to 125	T75BQ	Samples
TMP75BQDQ1	ACTIVE	SOIC	D	8	75	Green (RoHS & no Sb/Br)	CU NIPDAU-DCC	Level-2-260C-1 YEAR	-40 to 125	T75BQ	Samples
TMP75BQDRQ1	ACTIVE	SOIC	D	8	2500	Green (RoHS & no Sb/Br)	CU NIPDAU-DCC	Level-2-260C-1 YEAR	-40 to 125	T75BQ	Samples

(1) The marketing status values are defined as follows:

ACTIVE: Product device recommended for new designs.

LIFEBUY: TI has announced that the device will be discontinued, and a lifetime-buy period is in effect.

NRND: Not recommended for new designs. Device is in production to support existing customers, but TI does not recommend using this part in a new design.

PREVIEW: Device has been announced but is not in production. Samples may or may not be available.

OBSELETE: TI has discontinued the production of the device.

(2) Eco Plan - The planned eco-friendly classification: Pb-Free (RoHS), Pb-Free (RoHS Exempt), or Green (RoHS & no Sb/Br) - please check <http://www.ti.com/productcontent> for the latest availability information and additional product content details.

TBD: The Pb-Free/Green conversion plan has not been defined.

Pb-Free (RoHS): TI's terms "Lead-Free" or "Pb-Free" mean semiconductor products that are compatible with the current RoHS requirements for all 6 substances, including the requirement that lead not exceed 0.1% by weight in homogeneous materials. Where designed to be soldered at high temperatures, TI Pb-Free products are suitable for use in specified lead-free processes.

Pb-Free (RoHS Exempt): This component has a RoHS exemption for either 1) lead-based flip-chip solder bumps used between the die and package, or 2) lead-based die adhesive used between the die and leadframe. The component is otherwise considered Pb-Free (RoHS compatible) as defined above.

Green (RoHS & no Sb/Br): TI defines "Green" to mean Pb-Free (RoHS compatible), and free of Bromine (Br) and Antimony (Sb) based flame retardants (Br or Sb do not exceed 0.1% by weight in homogeneous material)

(3) MSL, Peak Temp. - The Moisture Sensitivity Level rating according to the JEDEC industry standard classifications, and peak solder temperature.

(4) There may be additional marking, which relates to the logo, the lot trace code information, or the environmental category on the device.

(5) Multiple Device Markings will be inside parentheses. Only one Device Marking contained in parentheses and separated by a "~" will appear on a device. If a line is indented then it is a continuation of the previous line and the two combined represent the entire Device Marking for that device.

(6) Lead/Ball Finish - Orderable Devices may have multiple material finish options. Finish options are separated by a vertical ruled line. Lead/Ball Finish values may wrap to two lines if the finish value exceeds the maximum column width.

Important Information and Disclaimer: The information provided on this page represents TI's knowledge and belief as of the date that it is provided. TI bases its knowledge and belief on information provided by third parties, and makes no representation or warranty as to the accuracy of such information. Efforts are underway to better integrate information from third parties. TI has taken and continues to take reasonable steps to provide representative and accurate information but may not have conducted destructive testing or chemical analysis on incoming materials and chemicals. TI and TI suppliers consider certain information to be proprietary, and thus CAS numbers and other limited information may not be available for release.

In no event shall TI's liability arising out of such information exceed the total purchase price of the TI part(s) at issue in this document sold by TI to Customer on an annual basis.

OTHER QUALIFIED VERSIONS OF TMP75B-Q1 :

- Catalog: [TMP75B](#)

NOTE: Qualified Version Definitions:

- Catalog - TI's standard catalog product

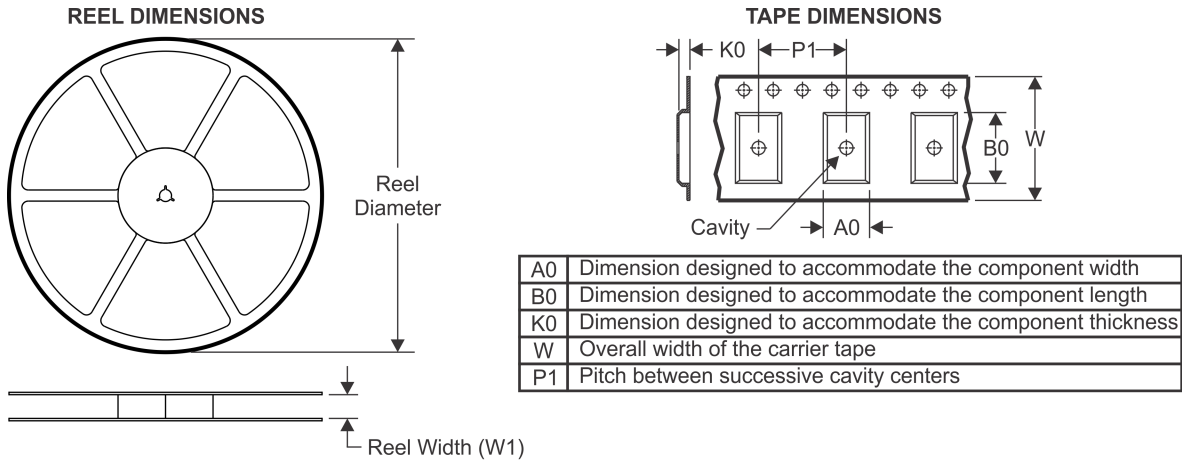
TAPE AND REEL INFORMATION

QUADRANT ASSIGNMENTS FOR PIN 1 ORIENTATION IN TAPE

*All dimensions are nominal

Device	Package Type	Package Drawing	Pins	SPQ	Reel Diameter (mm)	Reel Width W1 (mm)	A0 (mm)	B0 (mm)	K0 (mm)	P1 (mm)	W (mm)	Pin1 Quadrant
TMP75BQDGKRQ1	VSSOP	DGK	8	2500	330.0	12.4	5.3	3.4	1.4	8.0	12.0	Q1
TMP75BQDGKTQ1	VSSOP	DGK	8	250	330.0	12.4	5.3	3.4	1.4	8.0	12.0	Q1

TAPE AND REEL BOX DIMENSIONS



*All dimensions are nominal

Device	Package Type	Package Drawing	Pins	SPQ	Length (mm)	Width (mm)	Height (mm)
TMP75BQDGKRQ1	VSSOP	DGK	8	2500	366.0	364.0	50.0
TMP75BQDGKTQ1	VSSOP	DGK	8	250	366.0	364.0	50.0



- NOTES:
- A. All linear dimensions are in millimeters.
 - B. This drawing is subject to change without notice.
 - C. Publication IPC-7351 is recommended for alternate designs.
 - D. Laser cutting apertures with trapezoidal walls and also rounding corners will offer better paste release. Customers should contact their board assembly site for stencil design recommendations. Refer to IPC-7525 for other stencil recommendations.
 - E. Customers should contact their board fabrication site for solder mask tolerances between and around signal pads.

D (R-PDSO-G8)

PLASTIC SMALL OUTLINE

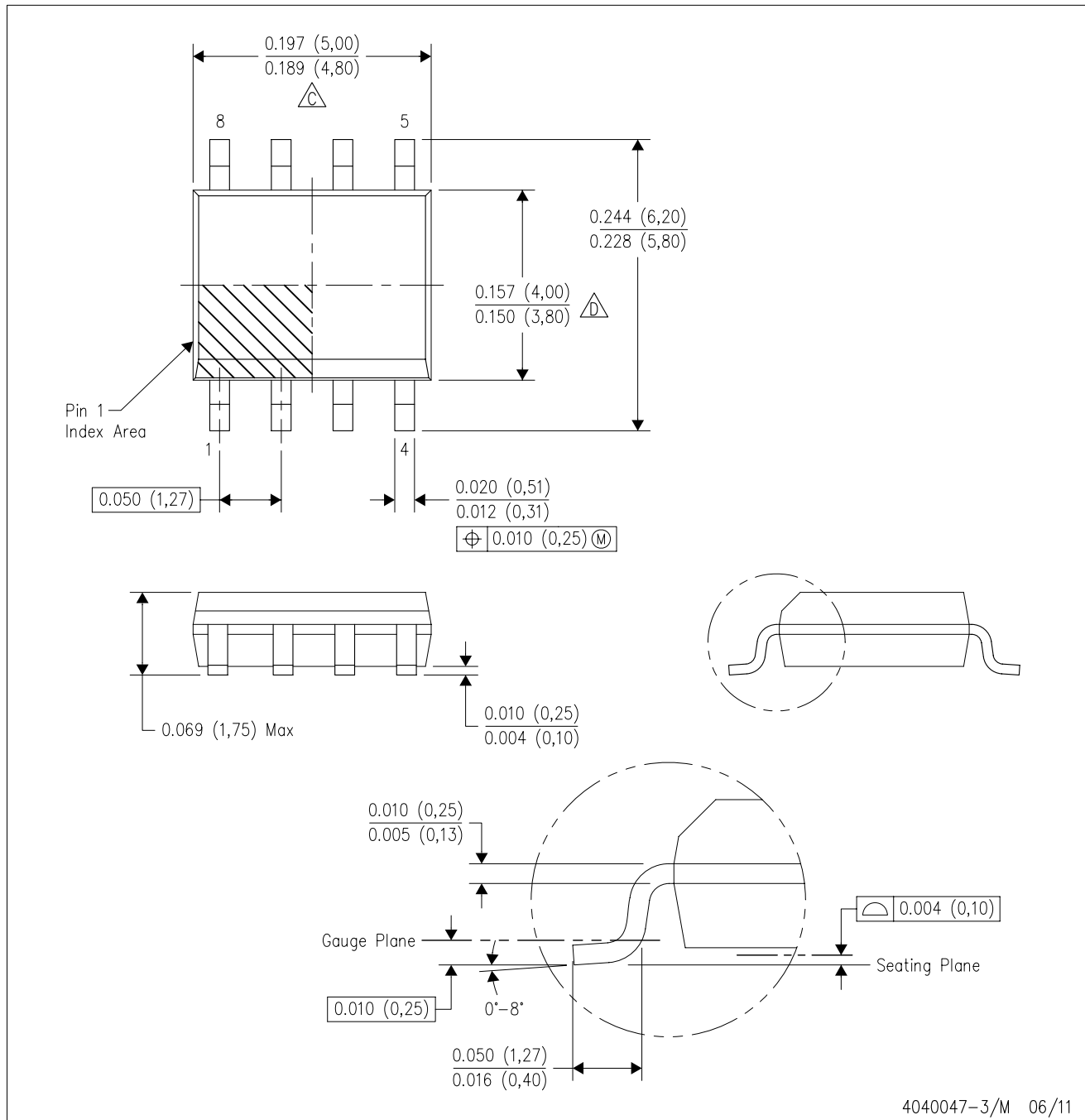

- NOTES:
- A. All linear dimensions are in inches (millimeters).
 - B. This drawing is subject to change without notice.
 - $\triangle C$ Body length does not include mold flash, protrusions, or gate burrs. Mold flash, protrusions, or gate burrs shall not exceed 0.006 (0,15) each side.
 - $\triangle D$ Body width does not include interlead flash. Interlead flash shall not exceed 0.017 (0,43) each side.
 - E. Reference JEDEC MS-012 variation AA.

IMPORTANT NOTICE

Texas Instruments Incorporated and its subsidiaries (TI) reserve the right to make corrections, enhancements, improvements and other changes to its semiconductor products and services per JESD46, latest issue, and to discontinue any product or service per JESD48, latest issue. Buyers should obtain the latest relevant information before placing orders and should verify that such information is current and complete. All semiconductor products (also referred to herein as "components") are sold subject to TI's terms and conditions of sale supplied at the time of order acknowledgment.

TI warrants performance of its components to the specifications applicable at the time of sale, in accordance with the warranty in TI's terms and conditions of sale of semiconductor products. Testing and other quality control techniques are used to the extent TI deems necessary to support this warranty. Except where mandated by applicable law, testing of all parameters of each component is not necessarily performed.

TI assumes no liability for applications assistance or the design of Buyers' products. Buyers are responsible for their products and applications using TI components. To minimize the risks associated with Buyers' products and applications, Buyers should provide adequate design and operating safeguards.

TI does not warrant or represent that any license, either express or implied, is granted under any patent right, copyright, mask work right, or other intellectual property right relating to any combination, machine, or process in which TI components or services are used. Information published by TI regarding third-party products or services does not constitute a license to use such products or services or a warranty or endorsement thereof. Use of such information may require a license from a third party under the patents or other intellectual property of the third party, or a license from TI under the patents or other intellectual property of TI.

Reproduction of significant portions of TI information in TI data books or data sheets is permissible only if reproduction is without alteration and is accompanied by all associated warranties, conditions, limitations, and notices. TI is not responsible or liable for such altered documentation. Information of third parties may be subject to additional restrictions.

Resale of TI components or services with statements different from or beyond the parameters stated by TI for that component or service voids all express and any implied warranties for the associated TI component or service and is an unfair and deceptive business practice. TI is not responsible or liable for any such statements.

Buyer acknowledges and agrees that it is solely responsible for compliance with all legal, regulatory and safety-related requirements concerning its products, and any use of TI components in its applications, notwithstanding any applications-related information or support that may be provided by TI. Buyer represents and agrees that it has all the necessary expertise to create and implement safeguards which anticipate dangerous consequences of failures, monitor failures and their consequences, lessen the likelihood of failures that might cause harm and take appropriate remedial actions. Buyer will fully indemnify TI and its representatives against any damages arising out of the use of any TI components in safety-critical applications.

In some cases, TI components may be promoted specifically to facilitate safety-related applications. With such components, TI's goal is to help enable customers to design and create their own end-product solutions that meet applicable functional safety standards and requirements. Nonetheless, such components are subject to these terms.

No TI components are authorized for use in FDA Class III (or similar life-critical medical equipment) unless authorized officers of the parties have executed a special agreement specifically governing such use.

Only those TI components which TI has specifically designated as military grade or "enhanced plastic" are designed and intended for use in military/aerospace applications or environments. Buyer acknowledges and agrees that any military or aerospace use of TI components which have **not** been so designated is solely at the Buyer's risk, and that Buyer is solely responsible for compliance with all legal and regulatory requirements in connection with such use.

TI has specifically designated certain components as meeting ISO/TS16949 requirements, mainly for automotive use. In any case of use of non-designated products, TI will not be responsible for any failure to meet ISO/TS16949.

Products

Audio	www.ti.com/audio
Amplifiers	amplifier.ti.com
Data Converters	dataconverter.ti.com
DLP® Products	www.dlp.com
DSP	dsp.ti.com
Clocks and Timers	www.ti.com/clocks
Interface	interface.ti.com
Logic	logic.ti.com
Power Mgmt	power.ti.com
Microcontrollers	microcontroller.ti.com
RFID	www.ti-rfid.com
OMAP Applications Processors	www.ti.com/omap
Wireless Connectivity	www.ti.com/wirelessconnectivity

Applications

Automotive and Transportation	www.ti.com/automotive
Communications and Telecom	www.ti.com/communications
Computers and Peripherals	www.ti.com/computers
Consumer Electronics	www.ti.com/consumer-apps
Energy and Lighting	www.ti.com/energy
Industrial	www.ti.com/industrial
Medical	www.ti.com/medical
Security	www.ti.com/security
Space, Avionics and Defense	www.ti.com/space-avionics-defense
Video and Imaging	www.ti.com/video

TI E2E Community

e2e.ti.com