

# Product Document

# TMD2725

## ALS, and Small Aperture Proximity Sensor Module

### General Description

The device features advanced proximity measurement and digital ambient light sensing (ALS). The package has been designed to accommodate a single small aperture approach. The slim module incorporates an IR LED and factory calibrated LED driver. The proximity detection feature provides object detection (e.g. mobile device screen to user's ear) by photodiode detection of reflected IR energy (sourced by the integrated LED). Detect/release events are interrupt driven, and occur when proximity result crosses upper and/or lower threshold settings. The proximity engine features offset adjustment registers to compensate for unwanted IR energy reflection at the sensor. Proximity results are further improved by automatic ambient light subtraction. The ALS detection feature provides photopic light intensity data. The ALS photodiode has UV and IR blocking filters and a dedicated data converter producing 16-bit data. This architecture allows applications to accurately measure ambient light which enables devices to calculate illuminance to control display backlight.

*Ordering Information and Content Guide appear at end of datasheet.*

### Key Benefits & Features

The benefits and features of TMD2725, ALS, and Small Aperture Proximity Sensor Module are listed below:

**Figure 1:**  
Added Value of Using TMD2725

| Benefits  | Features   |
|---|--|
| <ul style="list-style-type: none"> <li>• Small aperture requirements</li> </ul>               | <ul style="list-style-type: none"> <li>• 1.055mm emitter to detector distance</li> </ul>   |
| <ul style="list-style-type: none"> <li>• Single device integrated optical solution</li> </ul> | <ul style="list-style-type: none"> <li>• ALS + proximity</li> <li>• 2mm x 3.65mm x 1mm</li> <li>• Integrated IR LED</li> <li>• Power management features</li> <li>• I<sup>2</sup>C fast mode interface compatible</li> </ul> |
| <ul style="list-style-type: none"> <li>• Accurate ambient light sensing</li> </ul>            | <ul style="list-style-type: none"> <li>• Photopic Ambient Light Sensor (ALS)</li> <li>• UV / IR blocking filters</li> <li>• Programmable gain and integration time</li> </ul>  |
| <ul style="list-style-type: none"> <li>• Reduced power consumption</li> </ul>                 | <ul style="list-style-type: none"> <li>• 1.8V power supply with 1.8V I<sup>2</sup>C bus</li> </ul>   |

### Applications

The TMD2725 applications include:

- Ambient light sensing
- Single hole proximity sensing
- Mobile phone touch screen disable

### Block Diagram

The functional blocks of this device are shown below:

Figure 2:  
Functional Blocks of TMD2725

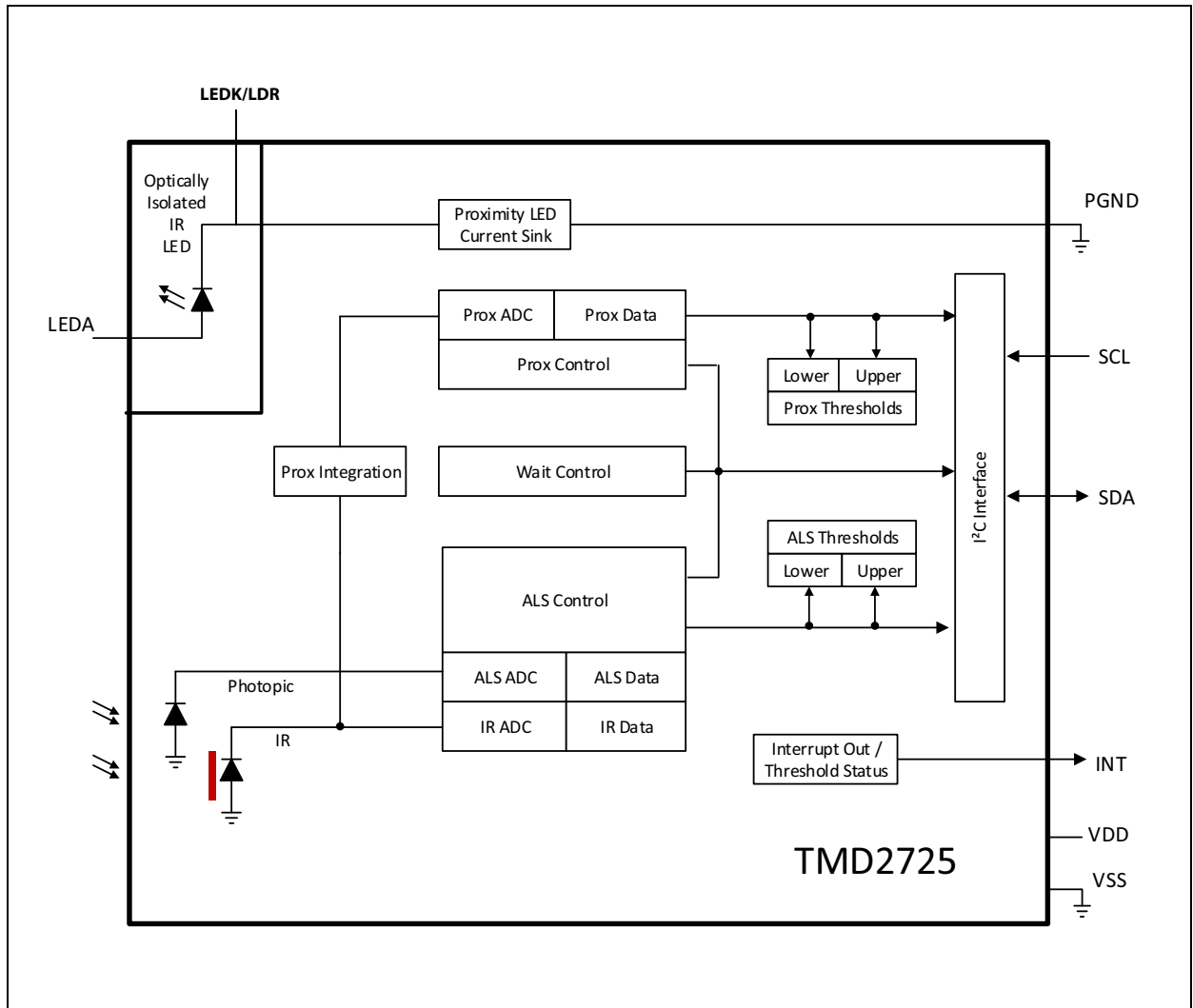

## Pin Assignments

**Figure 3:**  
Pin Diagram of TMD2725

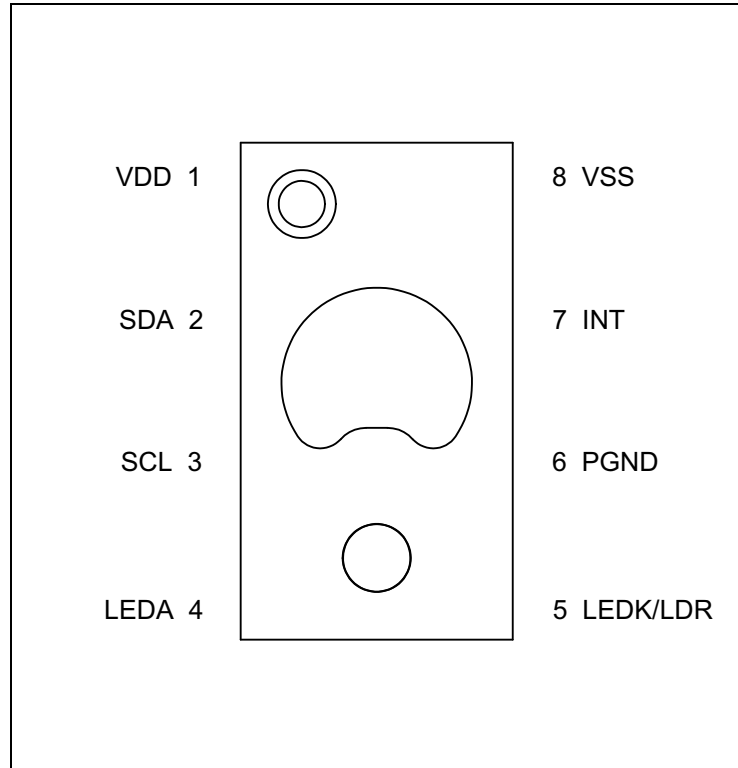

**Figure 4:**  
Pin Description of TMD2725 (8-Pin Module)

| Pin Number | Pin Name | Description   |
|------------|----------|---|
| 1          | VDD      | Supply voltage  |
| 2          | SDA      | I <sup>2</sup> C serial data I/O terminal   |
| 3          | SCL      | I <sup>2</sup> C serial clock input terminal  |
| 4          | LEDA     | LED anode   |
| 5          | LEDK/LDR | This test point is the junction of the LED cathode and internal current source. Do not connect. |
| 6          | PGND     | Ground for LED current sink and digital core  |
| 7          | INT      | Interrupt. Open drain output (active low)   |
| 8          | VSS      | Ground. All voltages are referenced to GND  |

## Absolute Maximum Ratings

Stresses beyond those listed under [Absolute Maximum Ratings](#) may cause permanent damage to the device. These are stress ratings only. Functional operation of the device at these or any other conditions beyond those indicated under [Electrical Characteristics](#) is not implied. Exposure to absolute maximum rating conditions for extended periods may affect device reliability.

**Figure 5:**  
Absolute Maximum Ratings

| Symbol   | Parameter  | Min    | Max | Units | Comments   |
|--|--|--------|-----|-------|--|
| <b>Electrical Parameters</b>                     |  |        |     |       |  |
| VDD  | Supply Voltage to Ground                           | -0.3   | 2.2 | V     |  |
| LEDA   | LED Voltage to PGND                                | -0.3   | 3.6 | V     |  |
| V <sub>IO</sub>                                  | Digital I/O terminal voltage                       | -0.3   | 3.6 | V     |  |
| I <sub>IO</sub>                                  | SDA, INT Output terminal current                   | -1     | 20  | mA    |  |
| <b>Electrostatic Discharge</b>                   |  |        |     |       |  |
| I <sub>SCR</sub>                                 | Input Current (latch up immunity)<br>JEDEC JESD78D | ± 100  |     | mA    | Class II   |
| ESD <sub>HBM</sub>                               | Electrostatic Discharge<br>HBM JS-001-2014         | ± 2000 |     | V     |  |
| ESD <sub>CDM</sub>                               | Electrostatic Discharge<br>CDM JEDEC JESD22-C101F  | ± 500  |     | V     |  |
| <b>Temperature Ranges and Storage Conditions</b> |  |        |     |       |  |
| T <sub>STRG</sub>                                | Storage Temperature Range                          | -40    | 85  | °C    |  |
| T <sub>BODY</sub>                                | Package Body Temperature                           |        | 260 | °C    | IPC/JEDEC J-STD-020<br>The reflow peak soldering temperature (body temperature) is specified according to IPC/JEDEC J-STD-020 "Moisture/Reflow Sensitivity Classification for Non-hermetic Solid State Surface Mount Devices." |
| RH <sub>NC</sub>                                 | Relative Humidity (non-condensing)                 | 5      | 85  | %     |  |
| MSL  | Moisture Sensitivity Level                         | 3      |     |       | Maximum floor life time 168 hours  |

## Electrical Characteristics

All limits are guaranteed. The parameters with min and max values are guaranteed with production tests or SQC (Statistical Quality Control) methods.

**Figure 6:**  
Recommended Operating Conditions

| Parameter  | Min | Typ | Max | Unit |
|--|-----|-----|-----|------|
| V <sub>DD</sub> supply range                                   | 1.7 | 1.8 | 2.0 | V    |
| V <sub>LEDA</sub> , Supply voltage range <sup>(1)</sup>        | 3.0 | 3.3 | 3.6 | V    |
| T <sub>A</sub> , Operating free-air temperature <sup>(2)</sup> | -30 |     | 85  | °C   |

**Note(s):**

- The minimum required supply voltage on the LED anode (V<sub>LEDA</sub>) is the sum of the LED's V<sub>F</sub> and the voltage drop from the LDR pin to PGND pin. The minimum required V<sub>LEDA</sub> can be lowered to 2.8V if the LED's forward current doesn't exceed 102mA (PLDRIVE value of 16 or less).
- While the device is operational across the temperature range, performance will vary with temperature. Operational characteristics are at 25°C, unless otherwise noted.

**Figure 7:**  
Operating Characteristics, V<sub>DD</sub> = 1.8V, T<sub>A</sub> = 25°C (unless otherwise noted)

| Symbol              | Parameter  | Conditions  | Min  | Typ   | Max  | Unit |
|---------------------|--|---|------|-------|------|------|
| f <sub>OSC</sub>    | Oscillator frequency   |   |      | 8.107 |      | MHz  |
| IDD                 | Supply Current <sup>(1)</sup>                                    | Active ALS State<br>(PON=AEN=1, PEN=0) <sup>(2)</sup> |      | 80    | 150  | µA   |
|                     |  | Idle State<br>(PON=1, AEN=PEN=0) <sup>(3)</sup>       |      | 30    | 60   |      |
|                     |  | Sleep State <sup>(4)</sup>                            |      | 0.7   | 5    |      |
| VOL                 | INT, SDA output low voltage                                      | 6mA sink current                                      |      |       | 0.6  | V    |
| I <sub>LEAK</sub>   | Leakage current, SDA,SCL,INT                                     |   | -5   |       | 5    | µA   |
| VIH                 | SCL, SDA input high voltage                                      |   | 1.26 |       | 3.3  | V    |
| VIL                 | SCL, SDA input low voltage                                       |   | 0    |       | 0.54 | V    |
| T <sub>Active</sub> | Time from power-on to ready to receive I <sup>2</sup> C commands |   |      | 1.5   |      | ms   |

**Note(s):**

- Values are shown at the VDD pin and do not include current through the IR LED.
- This parameter indicates the supply current during periods of ALS integration. If Wait is enabled (WEN=1), the supply current is lower during the Wait period.
- Idle state occurs when PON=1 and all functions are not enabled.
- Sleep state occurs when PON = 0 and I<sup>2</sup>C bus is idle. If Sleep state has been entered as the result of operational flow, SAI = 1, PON will remain high.

## Typical Operating Characteristics

Figure 8:  
Optical Characteristics, VDD = 1.8V, T<sub>A</sub> = 25°C (unless otherwise noted)

| Parameter  | Conditions   | Clear Channel |       |       | Unit                                    |
|--|--|---------------|-------|-------|---|
|  |  | Min           | Typ   | Max   |   |
| Re<br>Irradiance responsivity<br><br>Settings:<br>AGAIN = 16x<br>ATIME = 400ms | $\lambda_D = 465 \text{ nm LED}, 53.8 \mu\text{W}/\text{cm}^2$ |               | 58    |       | count/<br>( $\mu\text{W}/\text{cm}^2$ ) |
|  | $\lambda_D = 530 \text{ nm LED}, 43.9 \mu\text{W}/\text{cm}^2$ |               | 490   |       |   |
|  | $\lambda_D = 620 \text{ nm LED}, 37.5 \mu\text{W}/\text{cm}^2$ |               | 405   |       |   |
|  | Warm White LED, 45.6 $\mu\text{W}/\text{cm}^2$                 |               | 363   |       |   |
|  | Warm White LED, 45.6 $\mu\text{W}/\text{cm}^2$                 | 14025         | 16500 | 18975 | counts                                  |
|  | $\lambda_D = 950 \text{ nm LED}, 21.1 \mu\text{W}/\text{cm}^2$ |               | 8     |       | count/<br>( $\mu\text{W}/\text{cm}^2$ ) |

Figure 9:  
ALS Optical Characteristics, VDD = 1.8V, T<sub>A</sub> = 25°C (unless otherwise noted)

| Parameter                                 | Conditions   | Min  | Typ   | Max  | Unit         |
|---|--|------|-------|------|--------------|
| Integration time step size                |  | 2.72 | 2.82  | 2.94 | ms           |
| Dark ADC count value                      | E <sub>e</sub> = 0 $\mu\text{W}/\text{cm}^2$<br>AGAIN: 64x<br>ATIME = 100ms (0x23) | 0    | 1     | 3    | counts       |
| Gain Scaling, relative to 1x gain setting | AGAIN = 1x   |      | 1     |      | x            |
|   | AGAIN = 4x   |      | 4     |      |              |
|   | AGAIN = 16x  |      | 16    |      |              |
|   | AGAIN = 64x  |      | 66    |      |              |
|   | AGAIN = 128x   |      | 140   |      |              |
| ADC noise                                 | AGAIN = 16x  |      | 0.005 |      | % full scale |

**Figure 10:**  
**Proximity Optical Characteristics, VDD = 1.8V, T<sub>A</sub> = 25°C (unless otherwise noted)**

| Parameter                             | Conditions  | Min | Typ | Max | Unit   |
|---------------------------------------|---|-----|-----|-----|--------|
| Part to part variation <sup>(1)</sup> | Conditions:<br>PGAIN = 2 (4x)<br>PLDRIVE = 8 (54mA)<br>PPULSE = 15 (16 pulses)<br>PPULSE_LEN = 1 (8μs)<br>d=23mm round target<br>30mm target distance   | 75  | 100 | 125 | %      |
| Response, absolute                    | Basic proximity measurement <sup>(2)</sup><br>Conditions:<br>PGAIN = 2 (4x),<br>PLDRIVE = 16 (102mA)<br>PPULSE = 15 (16 pulses)<br>PPULSE_LEN = 2 (16μs)<br>Target material:<br>90% reflective surface of Kodak gray card<br>Target Size: 100mm x 100mm<br>Target Distance: 100mm | 128 | 160 | 192 | counts |
| Response, no target                   | PGAIN = 2 (4x)<br>ILEDDRIVE = 16 (102mA)<br>PPULSE = 16 (17 Pulses)<br>Pulse Length = 2 (16μs)  | 0   |     | 20  |        |
| Noise/Signal <sup>(3)</sup>           | PGAIN = 2 (4x)<br>IRLEDDRIVE = 8 (54mA)<br>PPULSE = 15 (16 pulses)<br>PPULSE_LEN = 1 (8μs)<br>d=23mm round target<br>30mm target distance   |     |     | 1.2 | %      |

**Note(s):**

1. Production tested result is the average of 5 readings expressed relative to a calibrated response.
2. Representative result by characterization.
3. Production tested result is the average of 20 readings divided by the maximum proximity value 255.

Figure 11:  
Spectral Responsivity

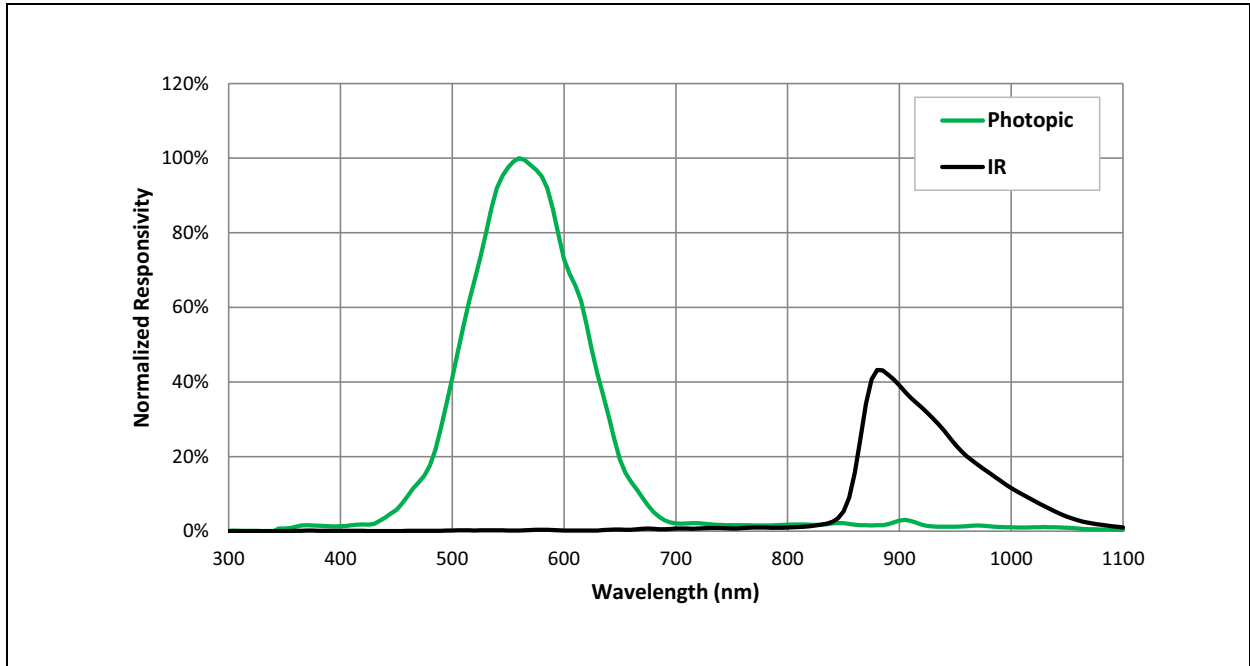
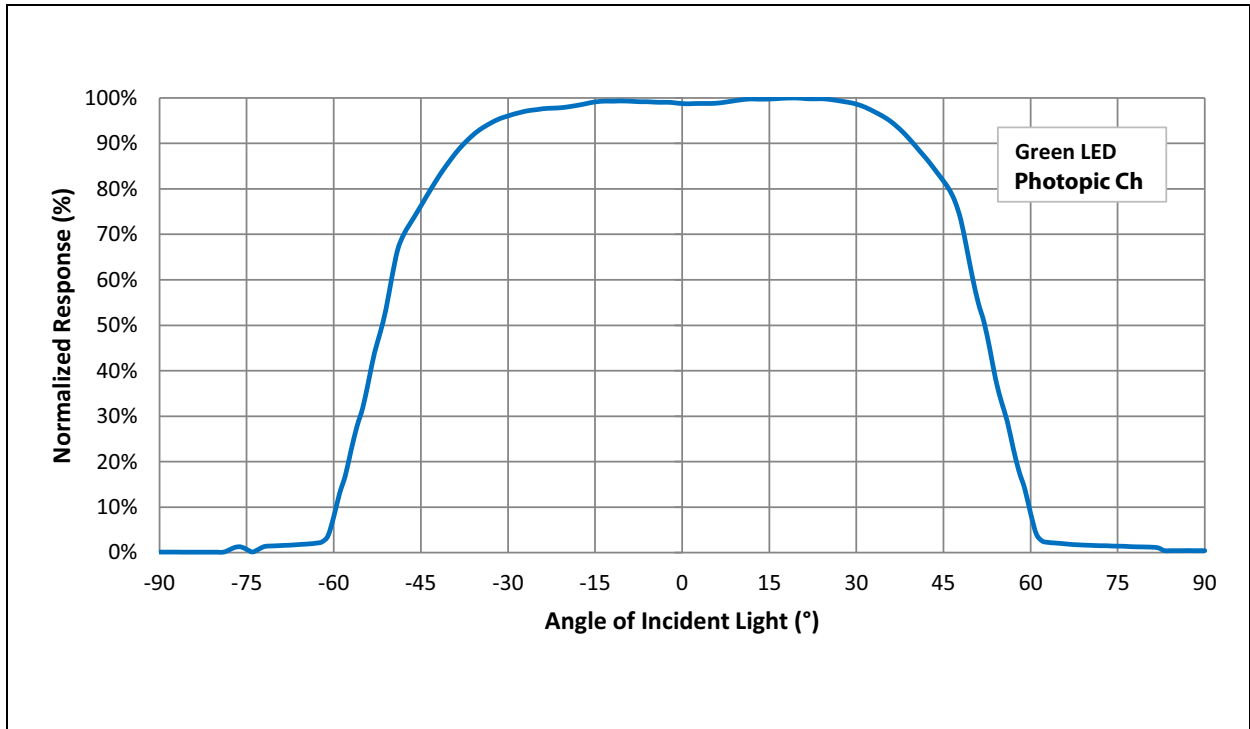
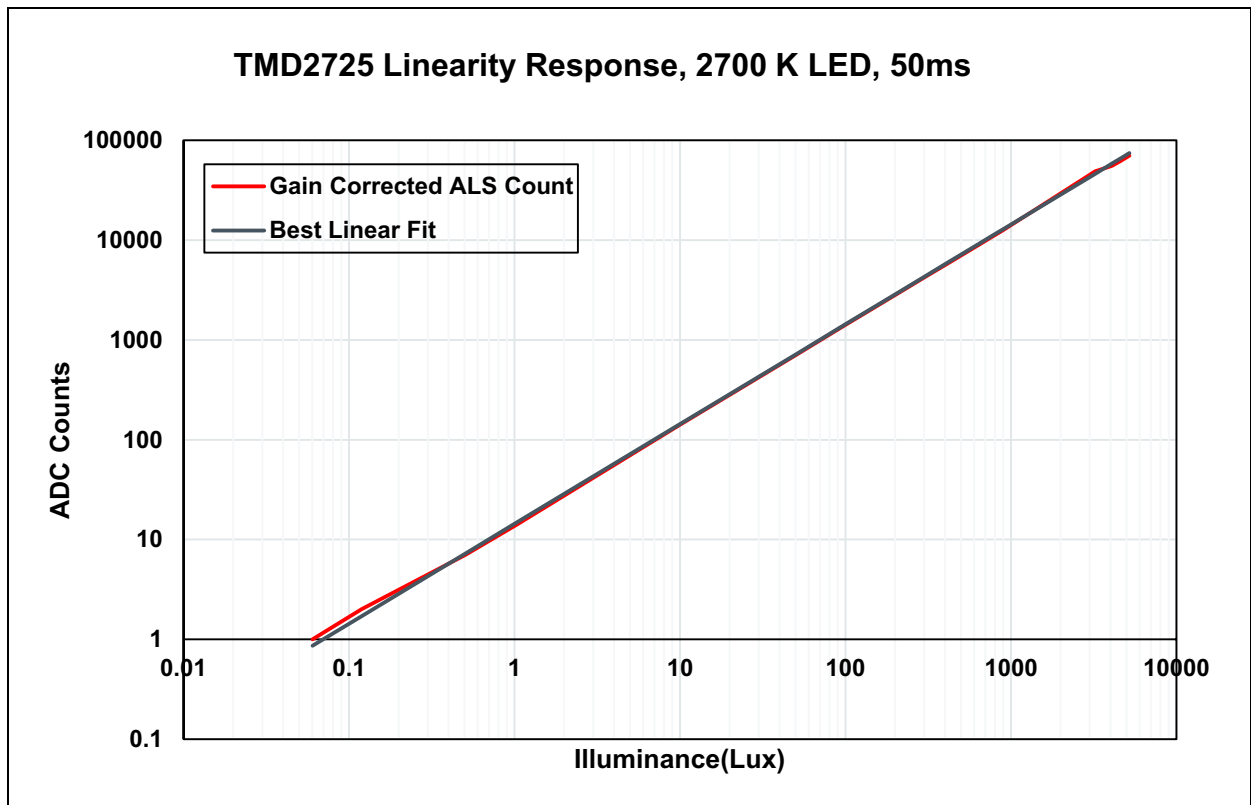

Figure 12:  
ALS Responsivity vs. Angular Displacement



**Figure 13:**  
ALS Linearity



**Figure 14:**  
Proximity Operation of TMD2725

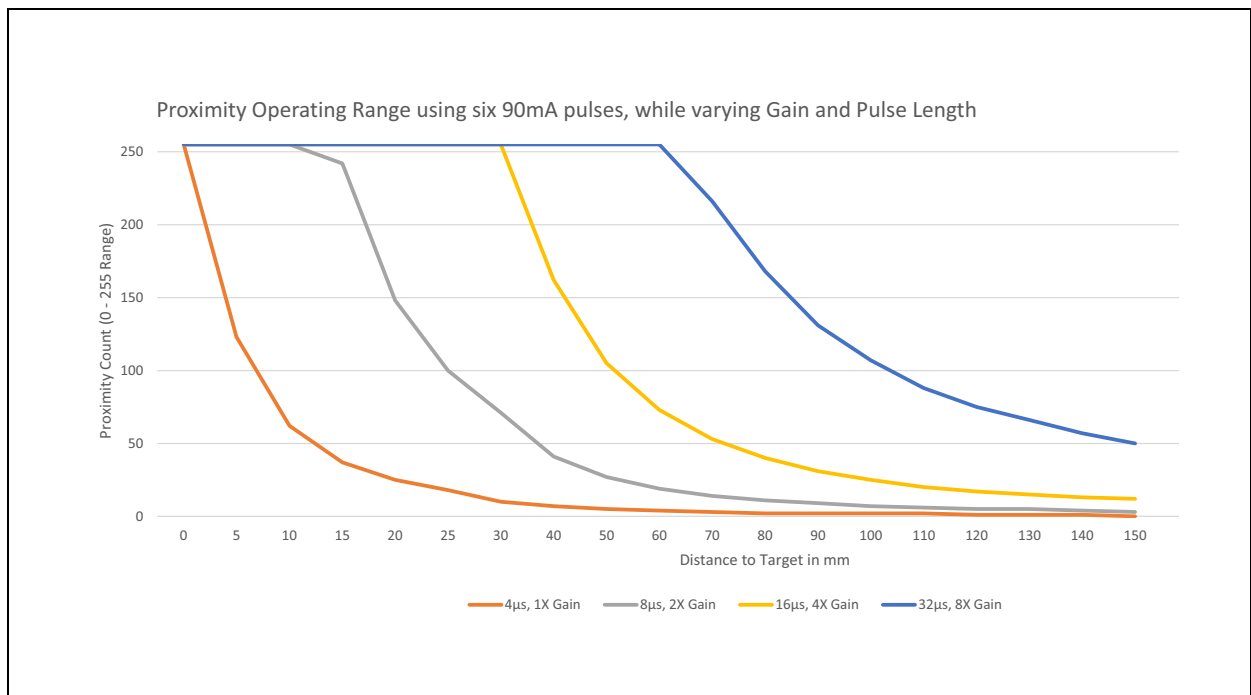

**Proximity Operation:** By varying Gain, LED drive current, number of LED pulses and LED pulse duration the proximity detection range can be adjusted.

## Detailed Description

### Proximity

Proximity results are affected by three fundamental factors: the integrated IR LED emission, IR reception, and environmental factors, including target distance and surface reflectivity.

The IR reception signal path begins with IR detection from a photodiode and ends with the 8-bit proximity result in PDATA register. Signal from the photodiode is amplified, and offset adjusted to optimize performance. Offset correction or cross-talk compensation is accomplished by adjustment to the POFFSET register.

The analog circuitry of the device applies the offset value as a subtraction to the signal accumulation; therefore a positive offset value has the effect of decreasing the results.

### Ambient Light Sensing, ALS

The ALS reception signal path begins as photodiodes receive filtered light and ends with the 16-bit results in the PHOTOPICL/H and ALS\_IRL/H registers. The Photopic photodiode is filtered with a UV and IR filter. The ALS\_IR photodiode is filtered to receive only IR. Signal from the photodiodes simultaneously accumulate for a period of time set by the value in ATIME before the results are available. Gain is adjustable from 1x to 64x to facilitate operation over a wide range of lighting conditions. Custom LUX equations are used to calculate the amount of ambient light, as well as, determine the light type (e.g. LED, fluorescent, incandescent, etc.) using the two ALS results.

### I<sup>2</sup>C Characteristics

The device uses I<sup>2</sup>C serial communication protocol for communication. The device supports 7-bit chip addressing and both standard and fast clock frequency modes with a chip address of 0x39. Read and Write transactions comply with the standard set by Philips (now NXP).

Internal to the device, an 8-bit buffer stores the register address location of the desired byte to read or write. This buffer auto-increments upon each byte transfer and is retained between transaction events (i.e. valid even after the master issues a STOP command and the I<sup>2</sup>C bus is released). During consecutive Read transactions, the future/repeated I<sup>2</sup>C Read transaction may omit the memory address byte normally following the chip address byte; the buffer retains the last register address + 1.

### I<sup>2</sup>C Write Transaction

A Write transaction consists of a START, CHIP-ADDRESS WRITE, REGISTER-ADDRESS, DATA BYTE(S), and STOP. Following each byte (9TH clock pulse) the slave places an ACKNOWLEDGE/ NOT-ACKNOWLEDGE (ACK/NACK) on the bus. If NACK is transmitted by the slave, the master may issue a STOP.

### I<sup>2</sup>C Read Transaction

A Read transaction consists of a START, CHIP-ADDRESS WRITE, REGISTER-ADDRESS, START, CHIP-ADDRESS READ, DATA BYTE(S), and STOP. Following all but the final byte the master places an ACK on the bus (9TH clock pulse). Termination of the Read transaction is indicated by a NACK being placed on the bus by the master, followed by STOP.

Alternately, if the previous I<sup>2</sup>C transaction was a Read, the internal register address buffer is still valid, allowing the transaction to proceed without “re”-specifying the register address. In this case the transaction consists of a START, CHIP-ADDRESS<sub>READ</sub>, DATA BYTE(S), and STOP. Following all but the final byte the master places an ACK on the bus (9TH clock pulse). Termination of the Read transaction is indicated by a NACK being placed on the bus by the master, followed by STOP.

The I<sup>2</sup>C bus protocol was developed by Philips (now NXP). For a complete description of the I<sup>2</sup>C protocol, please review the NXP I<sup>2</sup>C design specification at:

<https://www.i2c-bus.org/references/>

## Timing Diagrams

Figure 15:  
I<sup>2</sup>C Timing

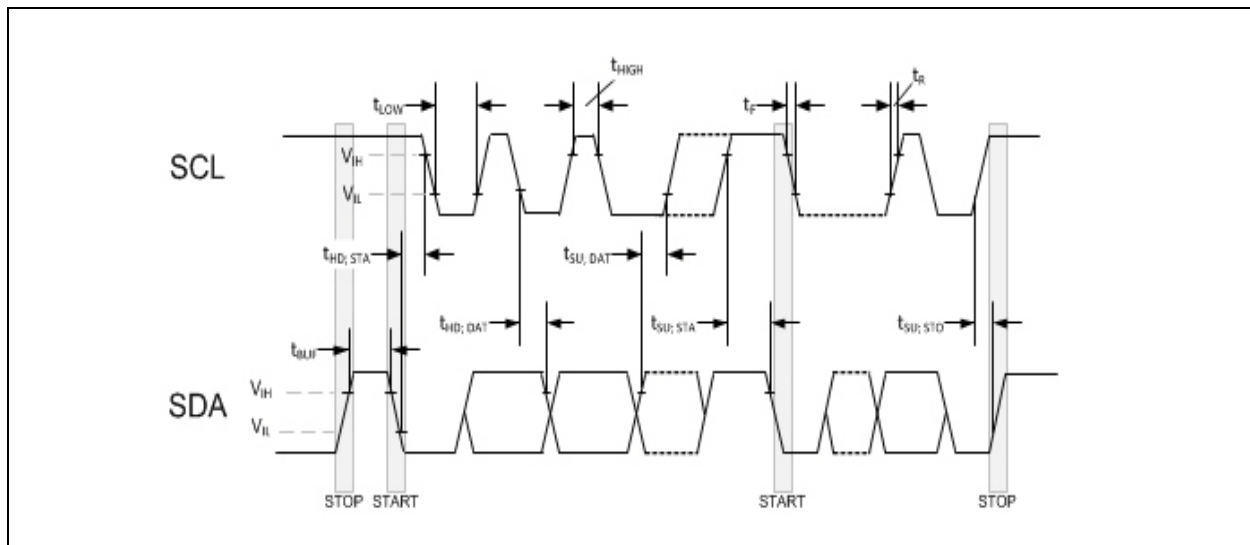

## Principles of Operation

### System State Machine

An internal state machine provides system control of the ALS, proximity detection, and power management features of the device. At power up, an internal power-on-reset initializes the device and puts it in a lowpower Sleep state. When a write on I<sup>2</sup>C bus to the Enable register (0x80) PON bit is set, the device transitions to the Idle state. If PON is disabled, the device will return to the Sleep state to save power. Otherwise, the device will remain in the Idle state until a Proximity or ALS function is enabled. Once enabled, the device will execute the ALS, Proximity and Wait states in sequence as indicated in [Figure 16](#) and [Figure 17](#). Upon completion, the device will automatically begin a new ALS-Prox-Wait cycle as long as PON and either PEN or AEN remain enabled. If the Prox or ALS function generates an interrupt and the Sleep-After-Interrupt (SAI) feature is enabled, the device will transition to the Sleep state and remain in a low-power mode until an I<sup>2</sup>C command is received clearing the interrupts in the STATUS register. See Interrupts for additional information.

**Figure 16:**  
**Detailed State Diagram**

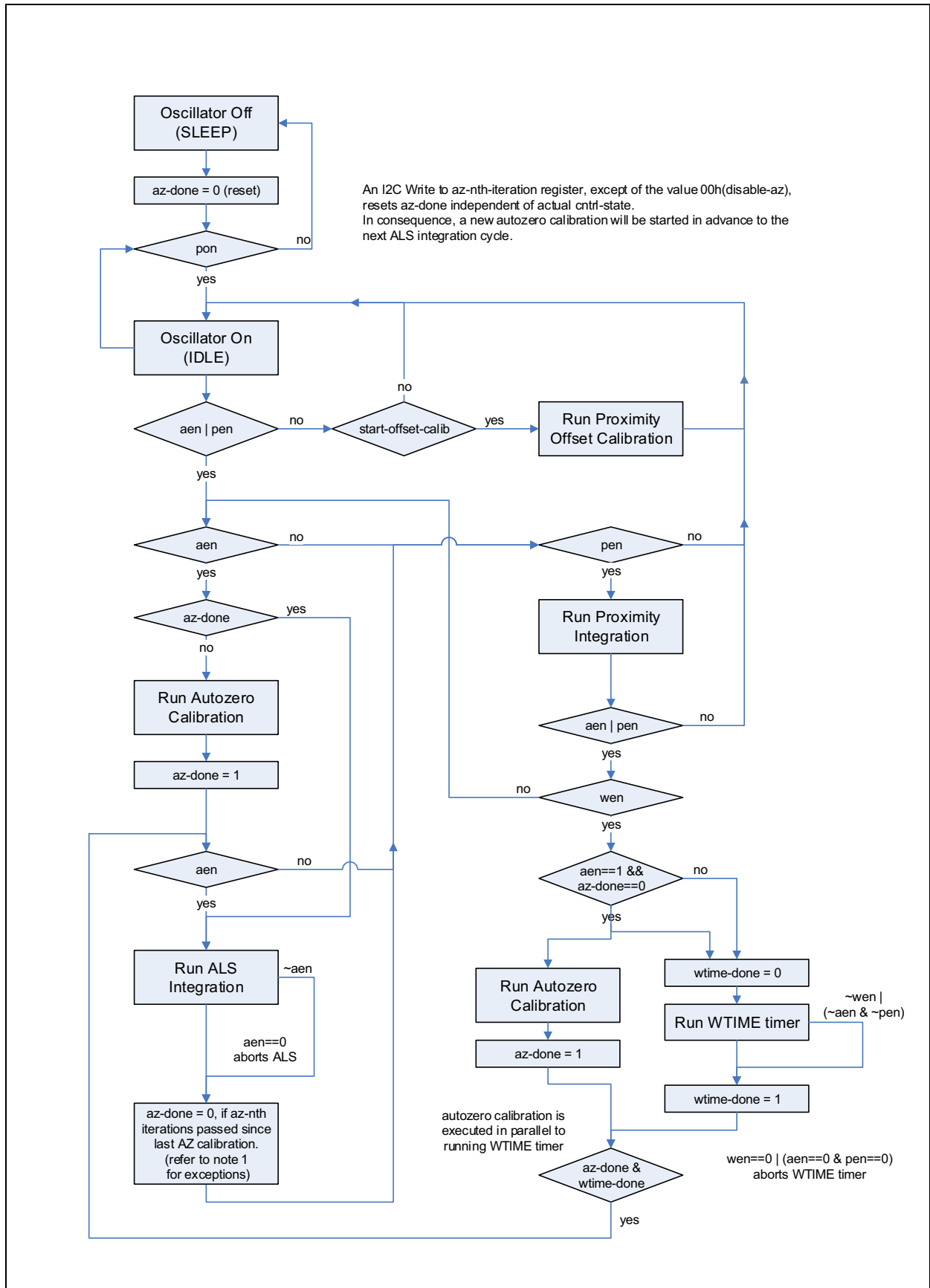
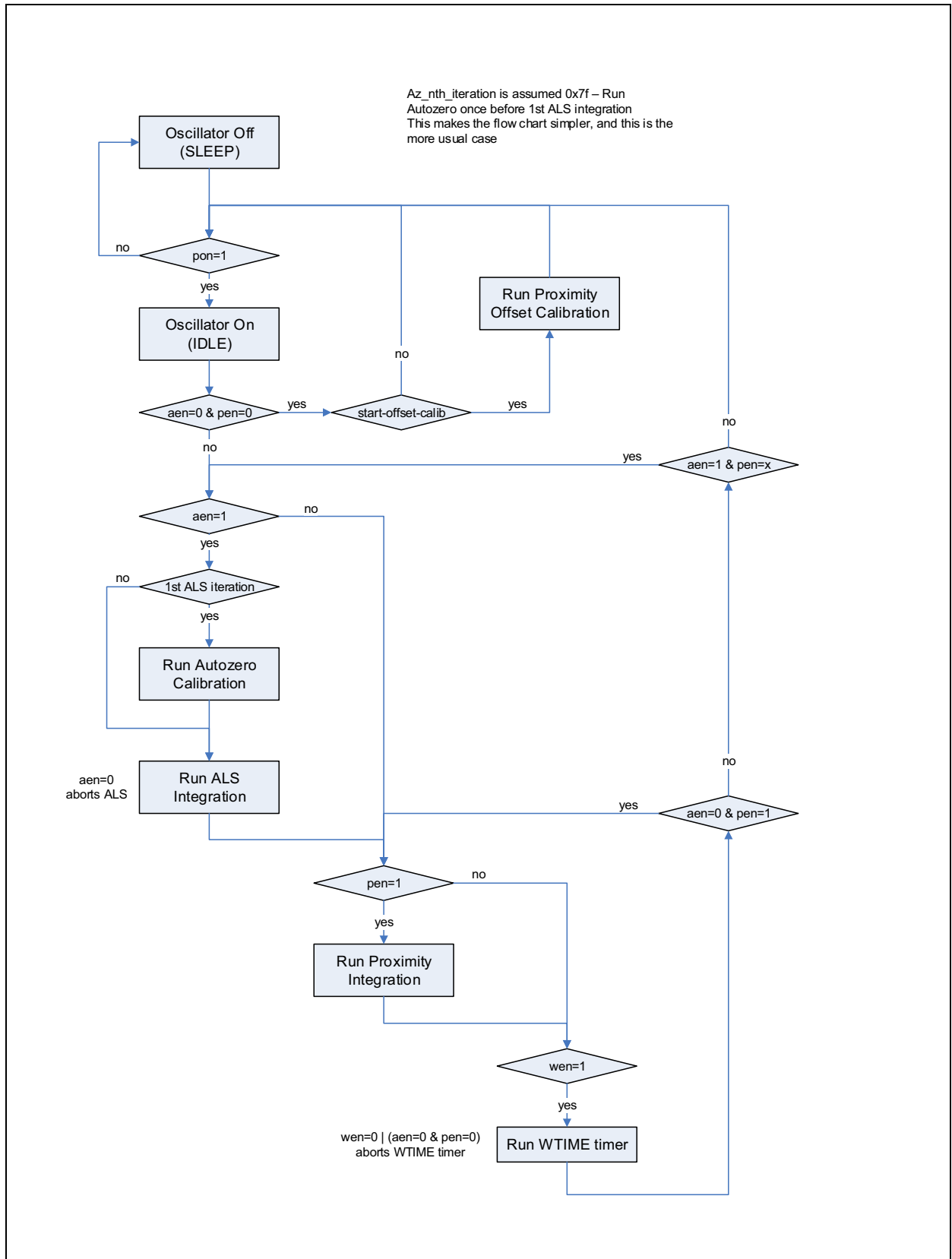

Figure 17:  
Simplified State Diagram



## Register Description

### Register Overview

**Figure 18:**  
Register Overview

| Address | Register Name | R/W | Register Function                      | Reset Value |
|---------|---------------|-----|--|-------------|
| 0x80    | ENABLE        | R/W | Enables states and functions           | 0x00        |
| 0x81    | ATIME         | R/W | ALS integration time                   | 0x00        |
| 0x82    | PRATE         | R/W | Proximity sampling time                | 0x1F        |
| 0x83    | WTIME         | R/W | Wait time                              | 0x00        |
| 0x84    | AILTL         | R/W | ALS interrupt low threshold low byte   | 0x00        |
| 0x85    | AILTH         | R/W | ALS interrupt low threshold high byte  | 0x00        |
| 0x86    | AIHTL         | R/W | ALS interrupt high threshold low byte  | 0x00        |
| 0x87    | AIHTH         | R/W | ALS interrupt high threshold high byte | 0x00        |
| 0x88    | PILT          | R/W | Proximity interrupt low threshold      | 0x00        |
| 0x8A    | PIHT          | R/W | Proximity interrupt high threshold     | 0x00        |
| 0x8C    | PERS          | R/W | Interrupt persistence filters          | 0x00        |
| 0x8D    | CFG0          | R/W | Configuration register zero            | 0x80        |
| 0x8E    | PCFG0         | R/W | Proximity configuration register zero  | 0x4F        |
| 0x8F    | PCFG1         | R/W | Proximity configuration register one   | 0x80        |
| 0x90    | CFG1          | R/W | Configuration register one             | 0x00        |
| 0x91    | REVID         | R   | Revision ID                            | 0x20        |
| 0x92    | ID            | R   | Device ID                              | 0xE4        |
| 0x93    | STATUS        | R   | Device status register                 | 0x00        |
| 0x94    | PHOTOPICL     | R   | Photopic channel data low byte         | 0x00        |
| 0x95    | PHOTOPICH     | R   | Photopic channel data high byte        | 0x00        |
| 0x96    | ALS_IRL       | R   | IR channel data low byte               | 0x00        |
| 0x97    | ALS_IRH       | R   | IR channel data high byte              | 0x00        |
| 0x9C    | PDATA         | R   | Proximity channel data                 | 0x00        |
| 0x9E    | REVID2        | R   | Auxiliary ID                           | 0x00        |
| 0x9F    | CFG2          | R/W | Configuration register two             | 0x04        |
| 0xAB    | CFG3          | R/W | Configuration register three           | 0x4C        |

| Address | Register Name | R/W | Register Function          | Reset Value |
|---------|---------------|-----|----------------------------|-------------|
| 0xC0    | POFFSETL      | R/W | Proximity offset magnitude | 0x00        |
| 0xC1    | POFFSETH      | R/W | Proximity offset sign      | 0x00        |
| 0xD6    | AZ_CONFIG     | R/W | Autozero configuration     | 0x7F        |
| 0xD7    | CALIB         | R/W | Calibration start          | 0x00        |
| 0xD9    | CALIBCFG      | R/W | Calibration configuration  | 0x50        |
| 0xDC    | CALIBSTAT     | R/W | Calibration status         | 0x00        |
| 0xDD    | INTENAB       | R/W | Interrupt enables          | 0x00        |

**Note(s):**

1. Address 0x98 and 0x99 will contain the results for the IR photodiode when controlled by the Green/IR MUX.

Register Access:

R = Read Only

W = Write Only

R/W = Read or Write

SC = Self Clearing after access

## Detailed Register Description

### *Enable Register (Address 0x80)*

**Figure 19:**  
Enable Register

| Addr: 0x80 |          | Enable  |        |   |
|------------|----------|---------|--------|---|
| Bit        | Bit Name | Default | Access | Bit Description   |
| 7:4        | RESERVED | 0000    | RW     | Reserved.   |
| 3          | WEN      | 0       | RW     | This bit activates the wait feature. Active high.   |
| 2          | PEN      | 0       | RW     | This bit activates the proximity detection. Active high.  |
| 1          | AEN      | 0       | RW     | This bit activates the ALS function. Active high.<br>*Set AEN=1 and PON=1 in the same command to ensure auto-zero function is run prior to the first measurement. |
| 0          | PON      | 0       | RW     | This field activates the internal oscillator and ADC channels. Active high.   |

Before activating AEN or PEN, preset each applicable operating mode registers and bits.

**ATIME Register (Address 0x81)**

**Figure 20:**  
ATIME Register

| Addr: 0x81 |          | ATIME   |        |  |                           |                         |                          |
|------------|----------|---------|--------|--|---------------------------|-------------------------|--------------------------|
| Bit        | Bit Name | Default | Access | Bit Description  |                           |                         |                          |
| 7:0        | ATIME    | 0x00    | RW     | ALS value that specifies the integration time in 2.78ms intervals. 0x00 indicates 2.8ms. The maximum ALS value depends on the integration time. For every 2.78ms, the maximum value increases by 1024. This means that to be able to reach ALS full scale, the integration time has to be at least 64*2.8ms. |                           |                         |                          |
|            |          |         |        | <b>Value</b>   | <b>Integration Cycles</b> | <b>Integration Time</b> | <b>Maximum ALS Value</b> |
|            |          |         |        | 0x00   | 1                         | 2.8ms                   | 1023                     |
|            |          |         |        | 0x01   | 2                         | 5.6ms                   | 2047                     |
|            |          |         |        | ...  | ...                       | ...                     | ...                      |
|            |          |         |        | 0x3F   | 64                        | 180ms                   | 65535                    |
|            |          |         |        | ...  | ...                       | ...                     | ...                      |
| 0xFF       | 256      | 719ms   | 65535  |  |                           |                         |                          |

The ATIME register controls the integration time of the ALS ADCs. The timer is implemented with a down counter with 0x00 as the terminal count. The timer is clocked at a 2.8ms nominal rate. Loading 0x00 will generate a 2.8ms integration time, loading 0x01 will generate a 5.6ms integration time, and so forth. The RC oscillator runs at 8MHz nominal rate. This gets divided by 11 to generate the integration clock of 727kHz. One count in ATIME (nominal 2.8ms) are 2.78ms. This is 2048 integration clock cycles:  $125\text{ns} * 11 * 8 * 256 = 2.8\text{ms}$ .

**PTIME Register (Address 0x82)**

**Figure 21:**  
PTIME Register

| Addr: 0x82 |          | PTIME   |        |   |  |
|------------|----------|---------|--------|---|--|
| Bit        | Bit Name | Default | Access | Bit Description   |  |
| 7:0        | PTIME    | 0x1F    | RW     | This register defines the duration of 1 Prox Sample, which is $(PTIME + 1) * 88\mu\text{s}$ . |  |

### WTIME Register (Address 0x83)

Figure 22:  
WTIME Register

| Addr: 0x83 |          | WTIME   |        |   |                   |                  |
|------------|----------|---------|--------|---|-------------------|------------------|
| Bit        | Bit Name | Default | Access | Bit Description   |                   |                  |
| 7:0        | WTIME    | 0x00    | RW     | Value that specifies the wait time between ALS cycles in 2.78ms increments. |                   |                  |
|            |          |         |        | <b>Value</b>  | <b>Increments</b> | <b>Wait Time</b> |
|            |          |         |        | 0x00  | 1                 | 2.8ms (33.8ms)   |
|            |          |         |        | 0x01  | 2                 | 5.6ms (67.6ms)   |
|            |          |         |        | ...   | ...               | ...              |
|            |          |         |        | 0x3F  | 64                | 180ms (2.16s)    |
|            |          |         |        | ...   | ...               | ...              |
|            |          |         |        | 0xFF  | 256               | 719ms (8.65s)    |

The wait timer is implemented using a down counter.  
 Wait time = (value + 1) x 2.8ms. If WLONG is enabled then  
 Wait time = (value + 1) x 2.8ms. x 12.

### AILTL Register (Address 0x84)

Figure 23:  
AILTL Register

| Addr: 0x84 |          | AILTL   |        |   |
|------------|----------|---------|--------|---|
| Bit        | Bit Name | Default | Access | Bit Description   |
| 7:0        | AILTL    | 0x00    | RW     | This register sets the low byte of the LOW ALS threshold. |

The photopic channel is compared against low-going 16-bit threshold value set by AILTL and AILTH.

### ***AILTH Register (Address 0x85)***

**Figure 24:**  
AILTH Register

| Addr: 0x85 |          | AILTH   |        |  |
|------------|----------|---------|--------|--|
| Bit        | Bit Name | Default | Access | Bit Description  |
| 7:0        | AILTH    | 0x00    | RW     | This register sets the high byte of the LOW ALS threshold. |

The photopic channel is compared against low-going 16-bit threshold value set by AILTL and AILTH. The contents of the AILTH and AILTL registers are combined and treated as a sixteen bit threshold value. If the value generated by the photopic channel is below the AILTL/H threshold and the APERS value is reached, the AINT bit is asserted. If AIEN is set, then the INT pin will also assert. When setting the 16-bit ALS threshold AILTL must be written first, immediately follow by AILTH. Internally, the lower 8-bits are buffered until the upper 8-bits are written. As the upper 8-bits are written both the high and low bytes are simultaneously latched as a 16-bit value.

### ***AIHTL Register (Address 0x86)***

**Figure 25:**  
AIHTL Register

| Addr: 0x86 |          | AIHTL   |        |  |
|------------|----------|---------|--------|--|
| Bit        | Bit Name | Default | Access | Bit Description  |
| 7:0        | AIHTL    | 0x00    | RW     | This register sets the low byte of the HIGH ALS threshold. |

The photopic channel is compared against high-going 16-bit threshold value set by AIHTL and AIHTH. The contents of the AIHTH and AIHTL registers are combined and treated as a sixteen bit threshold value. If the value generated by the photopic channel is above the AIHTL/H threshold and the APERS value is reached, the AINT bit is asserted. If AIEN is set, then the INT pin will also assert. When setting the 16-bit ALS threshold AIHTL must be written first, immediately follow by AIHTH. Internally, the lower 8-bits are buffered until the upper 8-bits are written. As the upper 8-bits are written both the high and low bytes are simultaneously latched as a 16-bit value.

### ***AIHTH Register (Address 0x87)***

**Figure 26:**  
**AIHTH Register**

| Addr: 0x87 |          | AIHTH   |        |   |
|------------|----------|---------|--------|---|
| Bit        | Bit Name | Default | Access | Bit Description   |
| 7:0        | AIHTH    | 0x00    | RW     | This register sets the high byte of the HIGH ALS threshold. |

The photopic channel is compared against high-going 16-bit threshold value set by AIHTL and AIHTH.

The contents of the AIHTH and AIHTL registers are combined and treated as a sixteen bit threshold value. If the value generated by the photopic channel is above the AIHTL/H threshold and the APERS value is reached, the AINT bit is asserted. If AIEN is set, then the INT pin will also assert.

When setting the 16-bit ALS threshold AIHTL must be written first, immediately follow by AIHTH. Internally, the lower 8-bits are buffered until the upper 8-bits are written. As the upper 8-bits are written both the high and low bytes are simultaneously latched as a 16-bit value.

### ***PILT Register (Address 0x88)***

**Figure 27:**  
**PILT Register**

| Addr: 0x88 |          | PILT    |        |   |
|------------|----------|---------|--------|---|
| Bit        | Bit Name | Default | Access | Bit Description   |
| 7:0        | PILT     | 0x00    | RW     | This register sets the Proximity ADC channel low threshold. |

The proximity channel is compared against low-going 8-bit threshold value set by PILT.

If the value generated by the Proximity channel is below the PILT threshold and the PPERS value is reached, the PINT bit is asserted. If PIEN is set, then the INT pin will also assert.

### PIHT Register (Address 0x8A)

Figure 28:  
PIHT Register

| Addr: 0x8A |          | PIHT    |        |  |
|------------|----------|---------|--------|--|
| Bit        | Bit Name | Default | Access | Bit Description  |
| 7:0        | PIHT     | 0x00    | RW     | This register sets the Proximity ADC channel high threshold. |

The proximity channel is compared against high-going 8-bit threshold value set by PIHT. If the value generated by the Proximity channel is above the PIHT threshold and the PPERS value is reached, the PINT bit is asserted. If PIEN is set, then the INT pin will also assert.

### PERS Register (Address 0x8C)

Figure 29:  
PERS Register

| Addr: 0x8C |          | PERS    |        |  |  |
|------------|----------|---------|--------|--|--|
| Bit        | Bit Name | Default | Access | Bit Description                                      |  |
| 7:4        | PPERS    | 0000    | RW     | This register sets the Proximity persistence filter. |  |
|            |          |         |        | <b>Value</b>   | <b>Interrupt</b>                             |
|            |          |         |        | 0  | Every Proximity Cycle                        |
|            |          |         |        | 1  | Any value outside PILT/PIHT thresholds       |
|            |          |         |        | 2  | 2 consecutive proximity values out of range  |
|            |          |         |        | 3  | 3 consecutive proximity values out of range  |
|            |          |         |        | ...  | ....   |
|            |          |         |        | 15   | 15 consecutive proximity values out of range |

| Addr: 0x8C |          | PERS    |        |  |  |
|------------|----------|---------|--------|--|--|
| Bit        | Bit Name | Default | Access | Bit Description                                |  |
| 3:0        | APERS    | 0000    | RW     | This register sets the ALS persistence filter. |  |
|            |          |         |        | 0  | Every ALS Cycle                        |
|            |          |         |        | 1  | Any value outside ALS thresholds       |
|            |          |         |        | 2  | 2 consecutive ALS values out of range  |
|            |          |         |        | 3  | 3 consecutive ALS values out of range  |
|            |          |         |        | 4  | 5 consecutive ALS values out of range  |
|            |          |         |        | 5  | 10 consecutive ALS values out of range |
|            |          |         |        | 6  | 15 consecutive ALS values out of range |
|            |          |         |        | 7  | 20 consecutive ALS values out of range |
|            |          |         |        | ...  | ...                                    |
|            |          |         |        | 13   | 50 consecutive ALS values out of range |
|            |          |         |        | 14   | 55 consecutive ALS values out of range |
|            |          |         |        | 15   | 60 consecutive ALS values out of range |

The frequency of consecutive proximity channel results outside of threshold limits are counted; this count value is compared against the PPERS value. If the counter is equal to the PPERS value an interrupt is asserted. Any time a proximity channel result is inside the threshold values the counter is cleared. The frequency of consecutive photopic channel results outside of threshold limits are counted; this count value is compared against the APERS value. If the counter is equal to the APERS setting an interrupt is asserted. Any time a photopic channel result is inside the threshold values the counter is cleared.

**CFG0 Register (Address 0x8D)****Figure 30:**  
CFG0 Register

| Addr: 0x8D |          | CFG0    |        |  |
|------------|----------|---------|--------|--|
| Bit        | Bit Name | Default | Access | Bit Description  |
| 7:3        | Reserved | 10000   | RW     | This field must be set to the default value.   |
| 2          | WLONG    | 0       | RW     | When Wait Long is asserted the wait period as set by WTIME is increased by a factor of 12. |
| 1:0        | Reserved | 00      | RW     | This field must be set to the default value.   |

The wait timer is implemented using a down counter.  
 Wait time = (value +1) x 2.8ms. If WLONG is enabled then  
 Wait time = (value +1) x 2.8ms x 12.

### PCFG0 Register (Address 0x8E)

Figure 31:  
PCFG0 Register

| Addr: 0x8E |            | PCFG0   |        |   |                                 |
|------------|------------|---------|--------|---|---------------------------------|
| Bit        | Bit Name   | Default | Access | Bit Description                                       |                                 |
| 7:6        | PPULSE_LEN | 01      | RW     | Proximity Pulse Length                                |                                 |
|            |            |         |        | <b>Value</b>  | <b>Pulse Length</b>             |
|            |            |         |        | 0   | 4 $\mu$ s                       |
|            |            |         |        | 1   | 8 $\mu$ s                       |
|            |            |         |        | 2   | 16 $\mu$ s                      |
|            |            |         |        | 3   | 32 $\mu$ s                      |
| 5:0        | PPULSE     | 001111  | RW     | Maximum Number of Pulses in a single proximity cycle. |                                 |
|            |            |         |        | <b>Value</b>  | <b>Maximum Number of Pulses</b> |
|            |            |         |        | 0   | 1                               |
|            |            |         |        | 1   | 2                               |
|            |            |         |        | 2   | 3                               |
|            |            |         |        | ...   | ...                             |
|            |            |         |        | 63  | 64                              |

The PPULSE\_LEN field sets the width of all IR LED pulses within the proximity cycle. Longer pulses result in increased proximity range and typically result in less electrical noise generated in the analog front end. However, a setting of 8 $\mu$ s is recommended because less cumulative noise is generated during a proximity cycle.

The PPULSE field sets the maximum number of IR LED pulses that may occur in a proximity cycle. The proximity engine will automatically continue to add IR LED pulses, up to the value set in PPULSE or if a near-saturation condition occurs.

The dynamic range of the sensor is automatically adjusted to detect distant targets as well as prevent saturation from close targets.

This operation also reduces power consumption because proximity integration period is automatically shortened when a target is either too close or far from the sensor.

**PCFG1 Register (Address 0x8F)**
**Figure 32:**  
 PCFG1 Register

| Addr: 0x8F |          | PCFG1   |        |  |                    |                  |
|------------|----------|---------|--------|--|--------------------|------------------|
| Bit        | Bit Name | Default | Access | Bit Description  |                    |                  |
| 7:6        | PGAIN    | 10      | RW     | This field sets the gain of the proximity IR sensor.   |                    |                  |
|            |          |         |        | <b>Gain</b>  | <b>Value</b>       | <b>Bit Field</b> |
|            |          |         |        | 1x   | 0                  | 00b              |
|            |          |         |        | 2x   | 1                  | 01b              |
|            |          |         |        | 4x   | 2                  | 10b              |
| 8x         | 3        | 11b     |        |  |                    |                  |
| 5          | Reserved | 0       | RW     | Reserved   |                    |                  |
| 4:0        | PLDRIVE  | 00000   | RW     | This field sets the drive strength of the IR LED current. Values are approximate; actual current through LED is factory trimmed to normalize IR intensity. |                    |                  |
|            |          |         |        | <b>Value</b>   | <b>LED Current</b> |                  |
|            |          |         |        | 0  | 6mA                |                  |
|            |          |         |        | 1  | 12mA               |                  |
|            |          |         |        | $i_{LED} = 6(PLDRIVE + 1) \text{ mA}$  |                    |                  |
|            |          |         |        | 30   | 186mA              |                  |
| 31         | 192mA    |         |        |  |                    |                  |

**CFG1 Register (Address 0x90)****Figure 33:**  
CFG1 Register

| Addr: 0x90 |          | CFG1    |        |   |             |
|------------|----------|---------|--------|---|-------------|
| Bit        | Bit Name | Default | Access | Bit Description                             |             |
| 7:2        | Reserved | 000000  | RW     | Reserved                                    |             |
| 1:0        | AGAIN    | 00      | RW     | This field sets the gain of the ALS sensor. |             |
|            |          |         |        | <b>Value</b>                                | <b>Gain</b> |
|            |          |         |        | 0   | 1x          |
|            |          |         |        | 1   | 4x          |
|            |          |         |        | 2   | 16x         |
|            |          |         |        | 3   | 64x         |

**REVID Register (Address 0x91)****Figure 34:**  
REVID Register

| Addr: 0x91 |          | REVID   |        |                        |
|------------|----------|---------|--------|------------------------|
| Bit        | Bit Name | Default | Access | Bit Description        |
| 7:3        | Reserved | 00100   | RO     | Reserved               |
| 2:0        | REV_ID   | 000     | RO     | Device revision number |

**ID Register (Address 0x92)****Figure 35:**  
ID Register

| Addr: 0x92 |          | ID      |        |                             |
|------------|----------|---------|--------|-----------------------------|
| Bit        | Bit Name | Default | Access | Bit Description             |
| 7:2        | ID       | 111001  | RO     | Device type identification. |
| 1:0        | Reserved | 00      | RO     | Reserved                    |

**Status Register (Address 0x93)**

**Figure 36:**  
Status Register

| Addr: 0x93 |                 | Status Register |        |  |
|------------|-----------------|-----------------|--------|--|
| Bit        | Bit Name        | Default         | Access | Bit Description  |
| 7          | ASAT            | 0               | R, SC  | The Analog Saturation flag signals that the ALS results may be unreliable due to saturation of the AFE.  |
| 6          | PSAT            | 0               | R, SC  | The Proximity Saturation flag indicates that an ambient- or reflective-saturation event occurred during a previous proximity cycle.              |
| 5          | PINT            | 0               | R, SC  | The Proximity Interrupt flag indicates that proximity results have exceeded thresholds and persistence settings.                                 |
| 4          | AINT            | 0               | R, SC  | The ALS Interrupt flag indicates that ALS results (photopic channel) have exceeded thresholds and persistence settings.                          |
| 3          | CINT            | 0               | R, SC  | The Calibration Interrupt flag indicates that calibration has completed.   |
| 2          | Reserved        | 0               | R, SC  | Reserved   |
| 1          | PSAT_REFLECTIVE | 0               | R, SC  | The Reflective Proximity Saturation Interrupt flag signals that the AFE has saturated during the IR LED active portion of proximity integration. |
| 0          | PSAT_AMBIENT    | 0               | R, SC  | The Ambient Proximity Saturation Interrupt flag signals that the AFE has saturated during the IR LED inactive portion of proximity integration.  |

All flags in this register can be cleared by setting the bit high. Alternatively, if the CFG3.int\_read\_clear bit is set, then simply reading this register automatically clears all eight flags.

**PHOTOPICL Register (Address 0x94)**

**Figure 37:**  
PHOTOPICL Register

| Addr: 0x94 |           | PHOTOPICL |        |  |
|------------|-----------|-----------|--------|--|
| Bit        | Bit Name  | Default   | Access | Bit Description  |
| 7:0        | PHOTOPICL | 0x00      | RO     | This register contains the low byte of the 16-bit photopic channel data. |

**PHOTOPICH Register (Address 0x95)**

**Figure 38:**  
PHOTOPICH Register

| Addr: 0x95 |           | PHOTOPICH |        |   |
|------------|-----------|-----------|--------|---|
| Bit        | Bit Name  | Default   | Access | Bit Description   |
| 7:0        | PHOTOPICH | 0x00      | RO     | This register contains the high byte of the 16-bit photopic channel data. |

**ALS\_IRL Register (Address 0x96)**

**Figure 39:**  
ALS\_IRL Register

| Addr: 0x96 |          | ALS_IRL |        |  |
|------------|----------|---------|--------|--|
| Bit        | Bit Name | Default | Access | Bit Description  |
| 7:0        | ALS_IRL  | 0x00    | RO     | This register contains the low byte of the 16-bit IR channel data. |

**ALS\_IRH Register (Address 0x97)**

**Figure 40:**  
ALS\_IRH Register

| Addr: 0x97 |          | ALS_IRH |        |   |
|------------|----------|---------|--------|---|
| Bit        | Bit Name | Default | Access | Bit Description   |
| 7:0        | ALS_IRH  | 0x00    | RO     | This register contains the high byte of the 16-bit IR channel data. |

**PDATA Register (Address 0x9C)**

**Figure 41:**  
PDATA Register

| Addr: 0x9C |          | PDATA   |        |  |
|------------|----------|---------|--------|--|
| Bit        | Bit Name | Default | Access | Bit Description  |
| 7:0        | PDATA    | 0x00    | RO     | This register contains the 8-bit proximity channel data. |

**REVID2 Register (Address 0x9E)**
**Figure 42:**  
 REVID2 Register

| Addr: 0x9E |          | REVID2  |        |                        |
|------------|----------|---------|--------|------------------------|
| Bit        | Bit Name | Default | Access | Description            |
| 7:4        | Reserved | 0000    | RO     | Reserved               |
| 3:0        | REVID2   | 0000    | RO     | Package Identification |

**CFG2 Register (Address 0x9F)**
**Figure 43:**  
 CFG2 Register

| Addr: 0x9F |          | CFG2    |        |   |
|------------|----------|---------|--------|---|
| Bit        | Bit Name | Default | Access | Bit Description   |
| 7:5        | Reserved | 000     | RW     | Reserved  |
| 4          | AGAINMAX | 0       | RW     | This bit adjusts the overall ALS gain factor. See <a href="#">Figure 44</a> for recommended settings and corresponding overall ALS gain factor. |
| 3          | Reserved | 0       | RW     | Reserved  |
| 2          | AGAINL   | 1       | RW     | This bit adjusts the overall ALS gain factor. See <a href="#">Figure 44</a> for recommended settings and corresponding overall ALS gain factor. |
| 1:0        | Reserved | 00      | RW     | Reserved  |

The ALS gain can be adjusted using by setting the two AGAIN bits as well as the AGAINL bit which yields an overall range from  $\frac{1}{2}x$  to  $128x$ .

**Figure 44:**  
**AGAIN Range**

| AGAIN[1] | AGAIN[0] | AGAINMAX | AGAINL | Overall ALS Gain |
|----------|----------|----------|--------|------------------|
| 0        | 0        | 0        | 0      | ½                |
| 0        | 0        | 0        | 1      | 1                |
| 0        | 1        | 0        | 1      | 4                |
| 1        | 0        | 0        | 1      | 16               |
| 1        | 1        | 0        | 1      | 64               |
| 1        | 1        | 1        | 1      | 128              |

**CFG3 Register (Address 0xAB)**

**Figure 45:**  
**CFG3 Register**

| Addr: 0xAB |                | CFG3    |        |  |            |            |                   |
|------------|----------------|---------|--------|--|------------|------------|-------------------|
| Bit        | Bit Name       | Default | Access | Bit Description  |            |            |                   |
| 7          | INT_READ_CLEAR | 0       | RW     | If the Interrupt-Clear-by-Read bit is set, then all flag bits in the STATUS register will be reset whenever the STATUS register is read over I <sup>2</sup> C. |            |            |                   |
| 6:5        | Reserved       | 10      | RW     | Reserved   |            |            |                   |
| 4          | SAI            | 0       | RW     | The Sleep After Interrupt bit is used to place the device into a low power mode upon an interrupt pin assertion.   |            |            |                   |
|            |                |         |        | <b>PON</b>   | <b>SAI</b> | <b>INT</b> | <b>Oscillator</b> |
|            |                |         |        | 0  | X          | X          | OFF               |
|            |                |         |        | 1  | 0          | X          | ON                |
|            |                |         |        | 1  | 1          | 1          | ON                |
|            |                |         |        | 1  | 1          | 0          | OFF               |
| 3:0        | Reserved       | 1100    | RW     | Reserved   |            |            |                   |

The SAI bit sets the device operational mode following the completion of an ALS or proximity cycle. If AINT and AIEN are both set or if PINT and PIEN are both set, causing an interrupt on the INT pin, and the SAI bit is set, then the oscillator will deactivate. The Device will appear as if PON = 0, however, PON will read as 1. The device can only be reactivated (oscillator enabled) by clearing the interrupts in the STATUS register.

#### ***POFFSETL Register (Address 0xC0)***

**Figure 46:**  
POFFSETL Register

| Addr: 0xC0 |          | POFFSETL |        |  |
|------------|----------|----------|--------|--|
| Bit        | Bit Name | Default  | Access | Bit Description  |
| 7:0        | POFFSETL | 0x00     | RW     | This register contains the magnitude portion of proximity offset adjust value. |

Typically, optical and/or electrical crosstalk negatively influence proximity operation and results. The POFFSETL/POFFSETH registers provide a mechanism to remove system crosstalk from the proximity data. POFFSETL and POFFSETH contains the magnitude and sign of a value which adjusts PDATA generated in the AFE. An offset value in the range of  $\pm 255$  is possible.

#### ***POFFSETH Register (Address 0xC1)***

**Figure 47:**  
POFFSETH Register

| Addr: 0xC1 |              | POFFSETH |        |   |
|------------|--------------|----------|--------|---|
| Bit        | Bit Name     | Default  | Access | Bit Description   |
| 7:1        | Reserved     | 0000000  | RW     | Reserved  |
| 0          | POFFSET_SIGN | 0        | RW     | This register contains the sign portion of proximity offset adjust value. |

### AZ\_CONFIG Register (Address 0xD6)

Figure 48:  
AZ\_CONFIG Register

| Addr: 0xD6 |                  | AZ_CONFIG |        |  |
|------------|------------------|-----------|--------|--|
| Bit        | Bit Name         | Default   | Access | Description  |
| 7          | Reserved         | 0         | RW     | Reserved.  |
| 6:0        | AZ_NTH_ITERATION | 1111111   | RW     | Run autozero automatically before every nth ALS cycle (00h = never, n = every nth ALS cycle, and 7Fh = only before the first ALS cycle). |

### CALIB Register (Address 0xD7)

Figure 49:  
CALIB Register

| Addr: 0xD7 |                        | CALIB   |        |   |
|------------|------------------------|---------|--------|---|
| Bit        | Bit Name               | Default | Access | Bit Description   |
| 7:6        | Reserved               | 00      | RO     | Reserved  |
| 5          | ELECTRICAL_CALIBRATION | 0       | RW     | Selects proximity calibration type.<br>1 = electrical offset only.<br>0 = calibration compensates for electrical and optical crosstalk. |
| 4:1        | Reserved               | 0000    | RW     | Reserved  |
| 0          | START_OFFSET_CALIB     | 0       | RW     | Set to 1 to start a calibration sequence.   |

Proximity response in systems with electrical and optical crosstalk may be improved by using the calibration feature. Optical crosstalk is caused when the photodiode receives a small portion of the LED IR which was unintentionally reflected by a surface other than the target. Electrical offset is caused by electrical disturbance in the sensor AFE, and also influences the proximity result. The calibration routine adjusts the value in registers C0 and C1 until the proximity result is as close to BINSRCH\_TARGET as possible without becoming zero. Optical and electrical calibration function identically, except that during an electrical calibration the proximity photodiode is disconnected from the AFE.

An electrical only calibration can be initiated by setting the ELECTRICAL\_CALIBRATION and START\_OFFSET\_CALB bits. To perform an optical (and electrical) calibration do not set the ELECTRICAL\_CALIBRATION bit when setting the START\_OFFSET\_CALIB. The CINT flag will assert after calibration has

finished.

Upon completion Proximity offset registers are automatically loaded with calibration result.

### **CALIBCFG Register (Address 0xD9)**

**Figure 50:**  
CALIBCFG Register

| Addr: 0xD9 |                 | CALIBCFG |        |  |                     |
|------------|-----------------|----------|--------|--|---------------------|
| Bit        | Bit Name        | Default  | Access | Bit Description  |                     |
| 7:5        | BINSRCH_TARGET  | 010      | RW     | Proximity Result Target  |                     |
|            |                 |          |        | <b>Value</b>   | <b>PDATA Target</b> |
|            |                 |          |        | 0  | 0                   |
|            |                 |          |        | 1  | 1                   |
|            |                 |          |        | 2  | 3                   |
|            |                 |          |        | 3  | 7                   |
|            |                 |          |        | 4  | 15                  |
|            |                 |          |        | 5  | 31                  |
|            |                 |          |        | 6  | 63                  |
| 7          | 127             |          |        |  |                     |
| 4          | Reserved        | 1        | RW     | Reserved   |                     |
| 3          | AUTO_OFFSET_ADJ | 0        | RW     | The Proximity Auto Offset Adjust bit causes the value in POFFSETL register to decrement when PDATA equals zero at the completion of the proximity cycle. |                     |
| 2:0        | PROX_AVG        | 000      | RW     | The Proximity Averaging field defines the number of ADC samples collected and averaged during a cycle which become the proximity result.                 |                     |
|            |                 |          |        | <b>Value</b>   | <b>Sample Size</b>  |
|            |                 |          |        | 0  | Disable             |
|            |                 |          |        | 1  | 2                   |
|            |                 |          |        | 2  | 4                   |
|            |                 |          |        | 3  | 8                   |
|            |                 |          |        | 4  | 16                  |
|            |                 |          |        | 5  | 32                  |
|            |                 |          |        | 6  | 64                  |
| 7          | 128             |          |        |  |                     |

The binary search target field is used by the calibration feature to set the baseline value for PDATA when no target is present. For example, calibration of a device in open air, with no target, and BINSEARCH\_TARGET setting of 4 causes the PDATA value will be approximately 15 counts. This feature is useful because it forces PDATA result to always be above zero.

The PROX\_AVG field sets the number of ADC samples that are averaged to calculate the PDATA result.

### ***CALIBSTAT Register (Address 0xDC)***

**Figure 51:**  
**CALIBSTAT Register**

| Addr: 0xDC |                | CALIBSTAT |        |   |
|------------|----------------|-----------|--------|---|
| Bit        | Bit Name       | Default   | Access | Bit Description   |
| 7:1        | Reserved       | 0000000   | RW     | Reserved  |
| 0          | CALIB_FINISHED | 0         | RW     | This flag indicates that calibration has finished. It can only be cleared by setting this bit high. |

### ***INTENAB Register (Address 0xDD)***

**Figure 52:**  
**INTENAB Register**

| Addr: 0xDD |          | INTENAB |        |                                       |
|------------|----------|---------|--------|---------------------------------------|
| Bit        | Bit Name | Default | Access | Bit Description                       |
| 7          | ASIEN    | 0       | RW     | ALS Saturation Interrupt Enable       |
| 6          | PSIEN    | 0       | RW     | Proximity Saturation Interrupt Enable |
| 5          | PIEN     | 0       | RW     | Proximity Interrupt Enable            |
| 4          | AIEN     | 0       | RW     | ALS Interrupt Enable                  |
| 3          | CIEN     | 0       | RW     | Calibration Interrupt Enable          |
| 2:0        | Reserved | 000     | RW     | Reserved                              |

## Application Information

### Schematic

**Figure 53:**  
Typical Applications Circuit

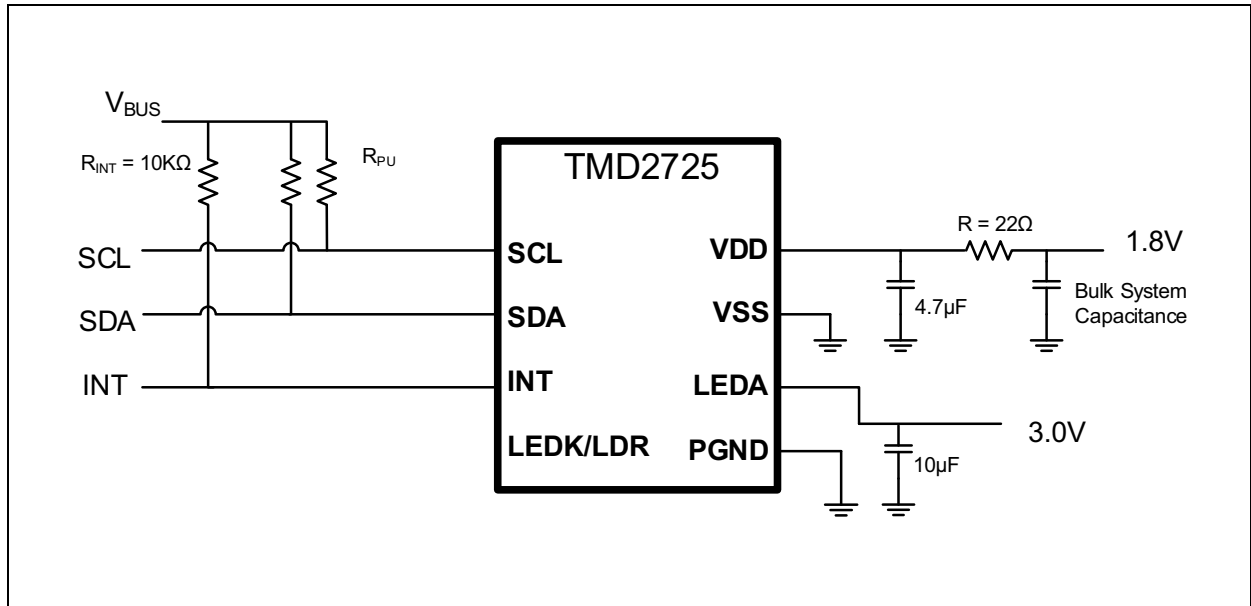

**Typical Applications Circuit:** It is important to place the  $4.7\mu F$  (VDD) and  $10\mu F$  (LEDA) capacitors at the package pins.

## PCB Layout

**Figure 54:**  
Typical Applications Circuit

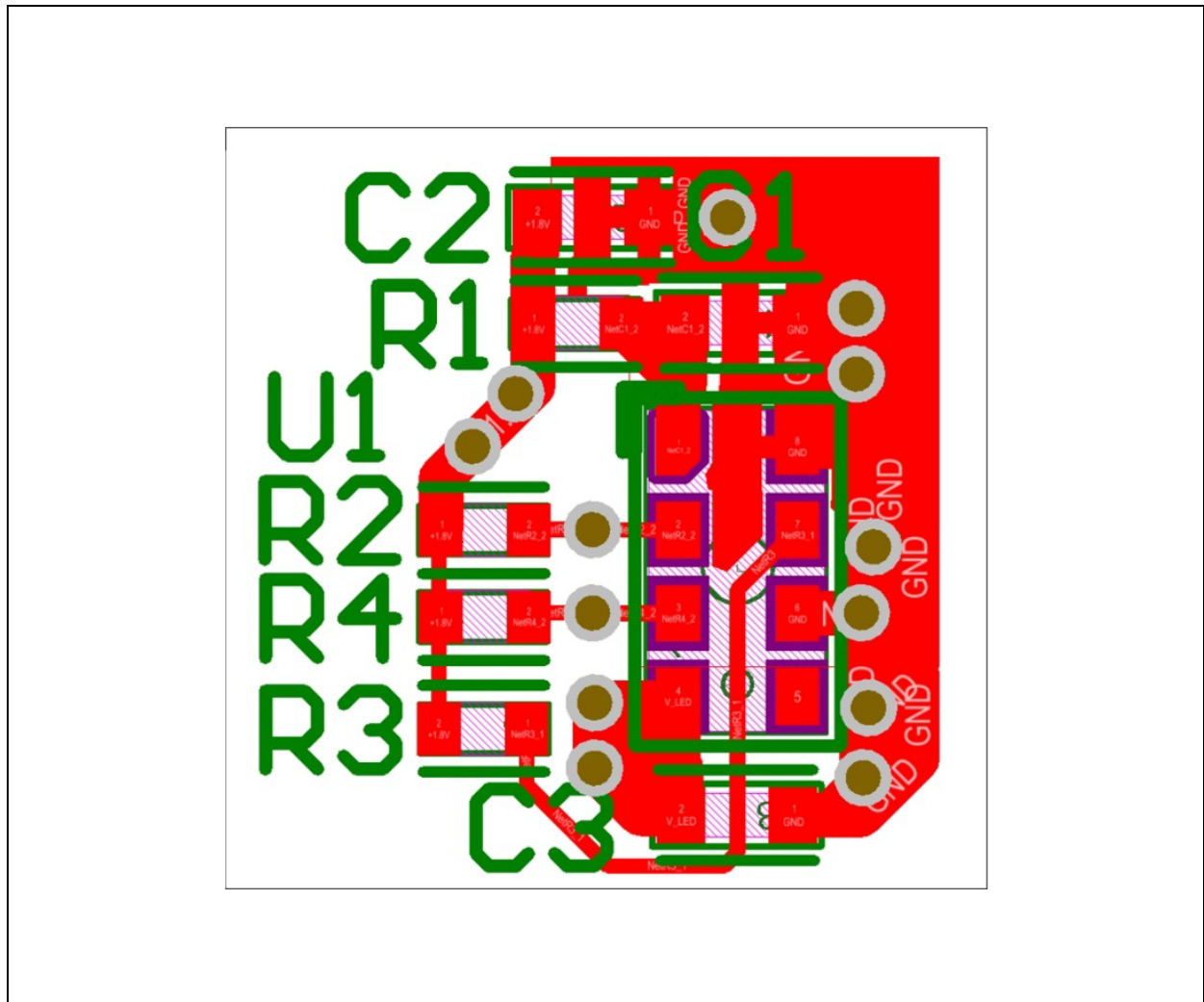

The dominant factor governing device performance is the component placement, not necessarily component value. The placement of the decoupling capacitor, C1, is the most critical. Place the component on the same side of PCB as device as shown in the figure above. Make connection as close as possible to minimize series inductance and resistance. This is critical.

## Package Drawings & Markings

Figure 55:  
Package Drawings

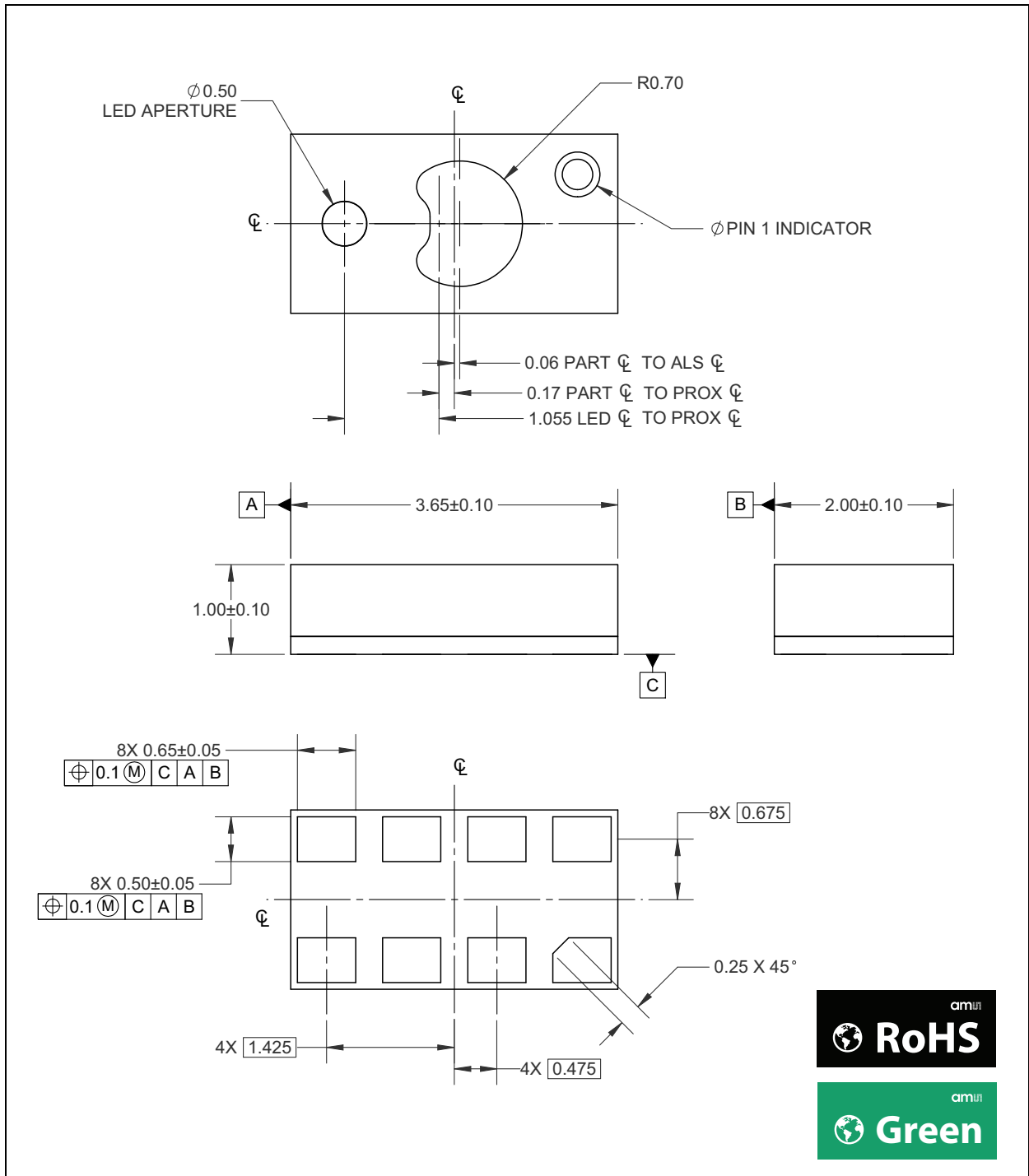

**Note(s):**

1. All linear dimensions are in millimeters.
2. Contact finish is Au.
3. This package contains no lead (Pb).
4. This drawing is subject to change without notice.

**Figure 56:**  
**Recommended PCB Layout**

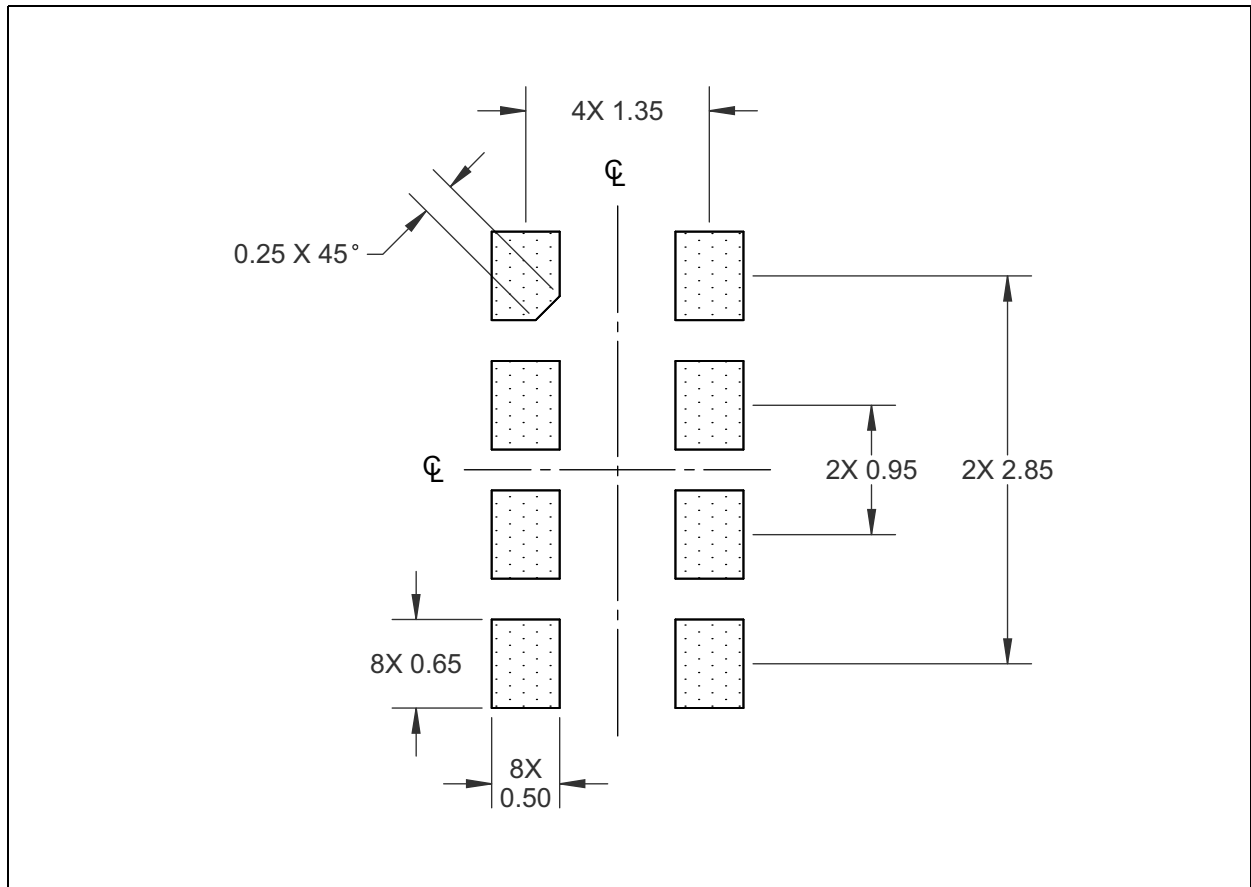

**Note(s):**

1. All dimensions are in millimeters.
2. Dimension tolerances are 0.05mm unless otherwise noted.
3. This drawing is subject to change without notice.

## Tape & Reel Information

**Figure 57:**  
Tape and Reel Information

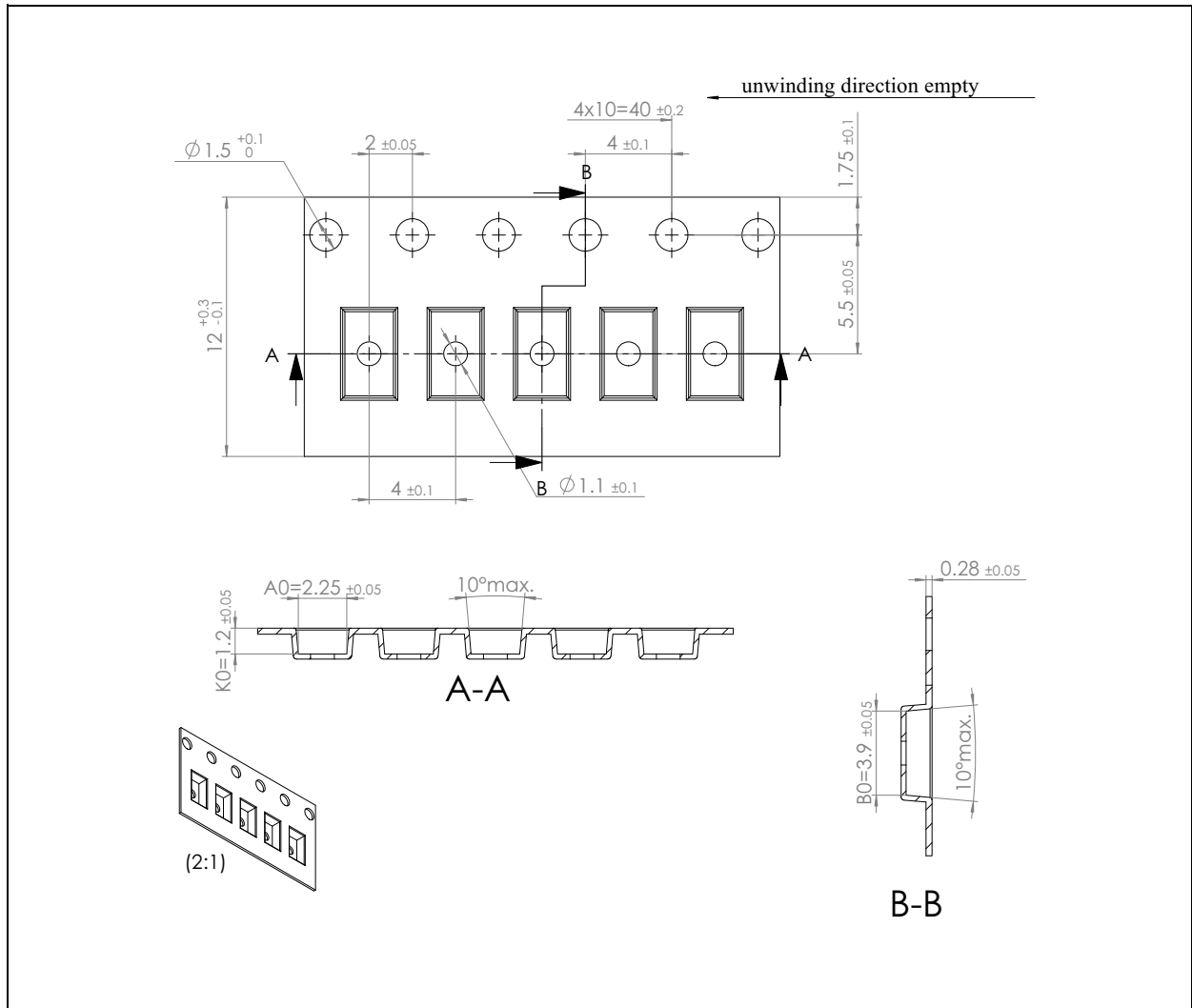

**Note(s):**

1. All linear dimensions are in millimeters.
2. For missing tolerances and dimensions, refer to EIA-481.
3. In accordance with EIA standard, device pin 1 is located next to the sprocket holes in the tape.

## Soldering & Storage Information

The module has been tested and has demonstrated an ability to be reflow soldered to a PCB substrate. The solder reflow profile describes the expected maximum heat exposure of components during the solder reflow process of product on a PCB. Temperature is measured on top of component. The components should be limited to a maximum of three passes through this solder reflow profile.

**Figure 58:**  
Solder Reflow Profile

| Profile Feature<br>Preheat/ Soak  | Sn-Pb Eutectic Assembly   | Pb-Free Assembly  |
|---|---|---|
| Temperature Min ( $T_{smin}$ )  | 100 °C  | 150 °C  |
| Temperature Max ( $T_{smax}$ )  | 150 °C  | 200 °C  |
| Time ( $t_s$ ) from ( $T_{smin}$ to $T_{smax}$ )  | 60-120 seconds  | 60-120 seconds  |
| Ramp-up rate ( $T_L$ to $T_p$ )   | 3 °C/second max.  | 3 °C/second max.  |
| Liquidous temperature ( $T_L$ )<br>Time ( $t_L$ ) maintained above $T_L$                        | 183 °C<br>60-150 seconds  | 217 °C<br>60-150 seconds  |
| Peak package body temperature ( $T_p$ )   | For users $T_p$ must not exceed the Classification temp of 235 °C<br>For suppliers $T_p$ must equal or exceed the Classification temp of 235 °C | For users $T_p$ must not exceed the Classification temp of 260 °C<br>For suppliers $T_p$ must equal or exceed the Classification temp of 260 °C |
| Time ( $t_p$ ) <sup>(1)</sup> within 5 °C of the specified classification temperature ( $T_c$ ) | 20 <sup>(1)</sup> seconds   | 30 <sup>(1)</sup> seconds   |
| Ramp-down rate ( $T_p$ to $T_L$ )   | 6 °C/second max.  | 6 °C/second max.  |
| Time 25 °C to peak temperature  | 6 minutes max.  | 8 minutes max.  |

**Note(s):**

1. Tolerance for peak profile temperature (TP) is defined as a supplier minimum and a user maximum.

Figure 59:  
Solder Reflow Profile Graph

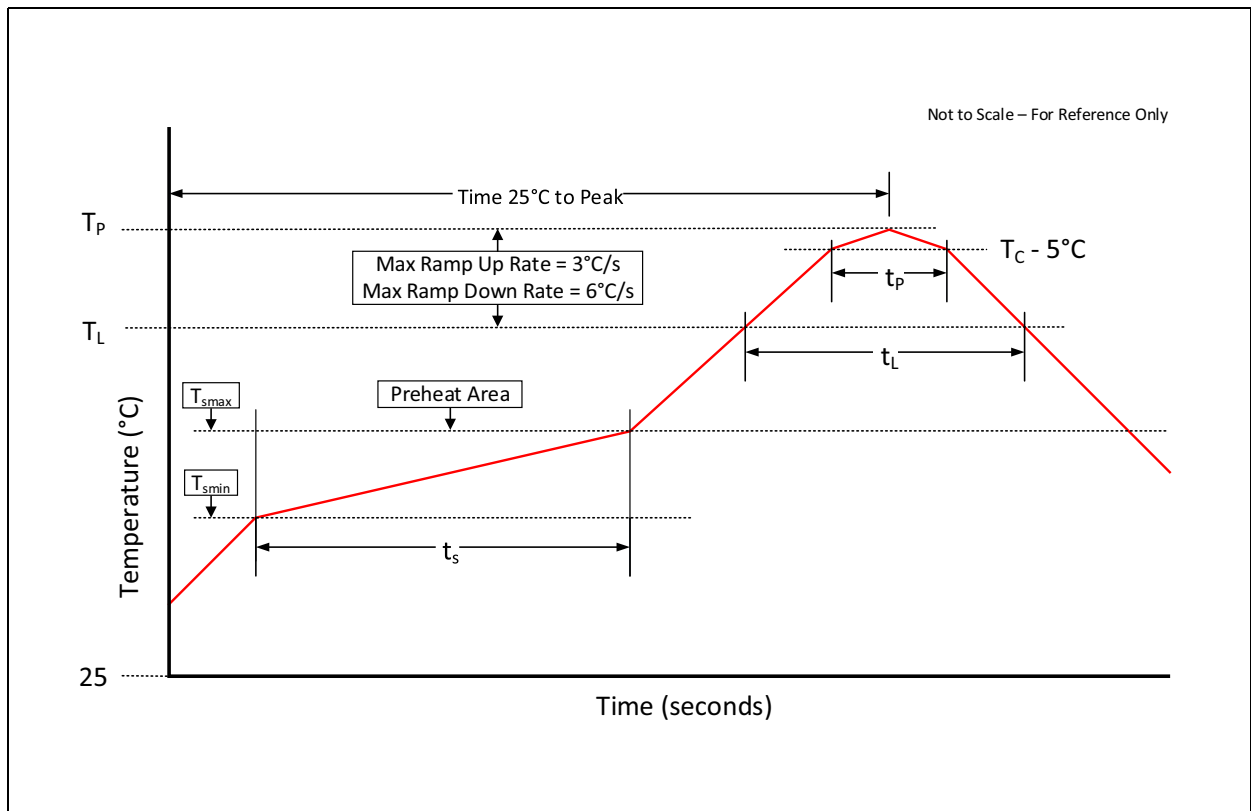

### Storage Information

Moisture Sensitivity Optical characteristics of the device can be adversely affected during the soldering process by the release and vaporization of moisture that has been previously absorbed into the package. To ensure the package contains the smallest amount of absorbed moisture possible, each device is baked prior to being dry packed for shipping. Devices are dry packed in a sealed aluminized envelope called a moisture-barrier bag with silica gel to protect them from ambient moisture during shipping, handling, and storage before use.

### Shelf Life

The calculated shelf life of the device in an unopened moisture barrier bag is 24 months from the date code on the bag when stored under the following conditions:

- Shelf Life: 24 months
- Ambient Temperature:  $<40^\circ C$
- Relative Humidity:  $<90\%$

Rebaking of the devices will be required if the devices exceed the 24 months shelf life and the Humidity Indicator Card shows that the devices were exposed to conditions beyond the allowable moisture region.

### **Floor Life**

The module has been assigned a moisture sensitivity level of MSL 3. As a result, the floor life of devices removed from the moisture barrier bag is 168 hours from the time the bag was opened, provided that the devices are stored under the following conditions:

- Floor Life: 168 hours
- Ambient Temperature: <30°C
- Relative Humidity: <60%

If the floor life or the temperature/humidity conditions have been exceeded, the devices must be rebaked prior to solder reflow or dry packing.

### **Rebaking Instructions**

When the shelf life or floor life limits have been exceeded, rebake at 50°C for 12 hours.

## Ordering & Contact Information

Figure 60:  
Ordering Information

| Ordering Code | I <sup>2</sup> C Bus | I <sup>2</sup> C Address | Delivery Form     | Delivery Quantity |
|---------------|----------------------|--------------------------|-------------------|-------------------|
| TMD27253M     | 1.8V                 | 39h                      | Tape & Reel (7")  | 1000 pcs/reel     |
| TMD27253      |                      |                          | Tape & Reel (13") | 10000 pcs/reel    |

Buy our products or get free samples online at:

[www.ams.com/Products](http://www.ams.com/Products)

Technical Support is available at:

[www.ams.com/Technical-Support](http://www.ams.com/Technical-Support)

Provide feedback about this document at:

[www.ams.com/Document-Feedback](http://www.ams.com/Document-Feedback)

For further information and requests, e-mail us at:

[ams\\_sales@ams.com](mailto:ams_sales@ams.com)

For sales offices, distributors and representatives, please visit:

[www.ams.com/Contact](http://www.ams.com/Contact)

### Headquarters

ams-OSRAM AG  
Tobelbader Strasse 30  
8141 Premstaetten  
Austria, Europe

Tel: +43 (0) 3136 500 0

Website: [www.ams.com](http://www.ams.com)

## RoHS Compliant & ams Green Statement

**RoHS:** The term RoHS compliant means that ams-OSRAM AG products fully comply with current RoHS directives. Our semiconductor products do not contain any chemicals for all 6 substance categories plus additional 4 substance categories (per amendment EU 2015/863), including the requirement that lead not exceed 0.1% by weight in homogeneous materials. Where designed to be soldered at high temperatures, RoHS compliant products are suitable for use in specified lead-free processes.

**ams Green (RoHS compliant and no Sb/Br/Cl):** ams Green defines that in addition to RoHS compliance, our products are free of Bromine (Br) and Antimony (Sb) based flame retardants (Br or Sb do not exceed 0.1% by weight in homogeneous material) and do not contain Chlorine (Cl not exceed 0.1% by weight in homogeneous material).

**Important Information:** The information provided in this statement represents ams-OSRAM AG knowledge and belief as of the date that it is provided. ams-OSRAM AG bases its knowledge and belief on information provided by third parties, and makes no representation or warranty as to the accuracy of such information. Efforts are underway to better integrate information from third parties. ams-OSRAM AG has taken and continues to take reasonable steps to provide representative and accurate information but may not have conducted destructive testing or chemical analysis on incoming materials and chemicals. ams-OSRAM AG and ams-OSRAM AG suppliers consider certain information to be proprietary, and thus CAS numbers and other limited information may not be available for release.

## Copyrights & Disclaimer

Copyright ams-OSRAM AG, Tobelbader Strasse 30, 8141 Premstaetten, Austria-Europe. Trademarks Registered. All rights reserved. The material herein may not be reproduced, adapted, merged, translated, stored, or used without the prior written consent of the copyright owner.

Devices sold by ams-OSRAM AG are covered by the warranty and patent indemnification provisions appearing in its General Terms of Trade. ams-OSRAM AG makes no warranty, express, statutory, implied, or by description regarding the information set forth herein. ams-OSRAM AG reserves the right to change specifications and prices at any time and without notice. Therefore, prior to designing this product into a system, it is necessary to check with ams-OSRAM AG for current information. This product is intended for use in commercial applications. Applications requiring extended temperature range, unusual environmental requirements, or high reliability applications, such as military, medical life-support or life-sustaining equipment are specifically not recommended without additional processing by ams-OSRAM AG for each application. This product is provided by ams-OSRAM AG "AS IS" and any express or implied warranties, including, but not limited to the implied warranties of merchantability and fitness for a particular purpose are disclaimed.

ams-OSRAM AG shall not be liable to recipient or any third party for any damages, including but not limited to personal injury, property damage, loss of profits, loss of use, interruption of business or indirect, special, incidental or consequential damages, of any kind, in connection with or arising out of the furnishing, performance or use of the technical data herein. No obligation or liability to recipient or any third party shall arise or flow out of ams-OSRAM AG rendering of technical or other services.

## Document Status

| Document Status          | Product Status  | Definition   |
|--------------------------|-----------------|--|
| Product Preview          | Pre-Development | Information in this datasheet is based on product ideas in the planning phase of development. All specifications are design goals without any warranty and are subject to change without notice  |
| Preliminary Datasheet    | Pre-Production  | Information in this datasheet is based on products in the design, validation or qualification phase of development. The performance and parameters shown in this document are preliminary without any warranty and are subject to change without notice                  |
| Datasheet                | Production      | Information in this datasheet is based on products in ramp-up to full production or full production which conform to specifications in accordance with the terms of ams-OSRAM AG standard warranty as given in the General Terms of Trade                                |
| Datasheet (discontinued) | Discontinued    | Information in this datasheet is based on products which conform to specifications in accordance with the terms of ams-OSRAM AG standard warranty as given in the General Terms of Trade, but these products have been superseded and should not be used for new designs |

## Revision Information

| Changes from 1-13 (2018-Feb-23) to current revision 2-00 (2023-Feb-22) | Page |
|--|------|
| Updated "Shelf Life" to 24 months                                      | 42   |

**Note(s):**

1. Page and figure numbers for the previous version may differ from page and figure numbers in the current revision.
2. Correction of typographical errors is not explicitly mentioned.

## Content Guide

|           |  |
|-----------|--|
| <b>1</b>  | <b>General Description</b>               |
| 1         | Key Benefits & Features                  |
| 2         | Applications                             |
| 2         | Block Diagram                            |
| <b>3</b>  | <b>Pin Assignments</b>                   |
| <b>4</b>  | <b>Absolute Maximum Ratings</b>          |
| <b>5</b>  | <b>Electrical Characteristics</b>        |
| <b>6</b>  | <b>Typical Operating Characteristics</b> |
| <b>10</b> | <b>Detailed Description</b>              |
| 10        | Proximity                                |
| 10        | Ambient Light Sensing, ALS               |
| 10        | I <sup>2</sup> C Characteristics         |
| 11        | I <sup>2</sup> C Write Transaction       |
| 11        | I <sup>2</sup> C Read Transaction        |
| 11        | Timing Diagrams                          |
| <b>12</b> | <b>Principles of Operation</b>           |
| 12        | System State Machine                     |
| <b>15</b> | <b>Register Description</b>              |
| 15        | Register Overview                        |
| 17        | Detailed Register Description            |
| 17        | Enable Register (Address 0x80)           |
| 18        | ATIME Register (Address 0x81)            |
| 18        | PTIME Register (Address 0x82)            |
| 19        | WTIME Register (Address 0x83)            |
| 19        | AILTL Register (Address 0x84)            |
| 20        | AILTH Register (Address 0x85)            |
| 20        | AIHTL Register (Address 0x86)            |
| 21        | AIHTH Register (Address 0x87)            |
| 21        | PILT Register (Address 0x88)             |
| 22        | PIHT Register (Address 0x8A)             |
| 22        | PERS Register (Address 0x8C)             |
| 24        | CFG0 Register (Address 0x8D)             |
| 25        | PCFG0 Register (Address 0x8E)            |
| 26        | PCFG1 Register (Address 0x8F)            |
| 27        | CFG1 Register (Address 0x90)             |
| 27        | REVID Register (Address 0x91)            |
| 27        | ID Register (Address 0x92)               |
| 28        | Status Register (Address 0x93)           |
| 28        | PHOTOPICL Register (Address 0x94)        |
| 29        | PHOTOPICH Register (Address 0x95)        |
| 29        | ALS_IRL Register (Address 0x96)          |
| 29        | ALS_IRH Register (Address 0x97)          |
| 29        | PDATA Register (Address 0x9C)            |
| 30        | REVID2 Register (Address 0x9E)           |
| 30        | CFG2 Register (Address 0x9F)             |
| 31        | CFG3 Register (Address 0xAB)             |
| 32        | POFFSETL Register (Address 0xC0)         |
| 32        | POFFSETH Register (Address 0xC1)         |
| 33        | AZ_CONFIG Register (Address 0xD6)        |
| 33        | CALIB Register (Address 0xD7)            |