



### Main

Range of product	Logic/motion controller - Modicon M262
Product or component type	Logic controller
[Us] rated supply voltage	24 V DC - 15...20 %
Discrete input number	4, discrete input fast input conforming to IEC 61131-2 Type 1
Discrete output type	Transistor
Discrete output number	4 transistor fast output
Discrete output voltage	24 V DC
Discrete I/O number	8
Communication port protocol	Ethernet IP/Modbus TCP Serial link Modbus RTU and ASCII HTTP HTTPS

### Complementary

Overvoltage protection	With
Discrete output current	0.5 A for transistor output (Q0...Q3) 0.5 A for fast output (Q0...Q3)
Maximum number of I/O expansion module	7 (remote) 7 (local)
Supply voltage limits	20.4...28.8 V DC
Inrush current	40 A
PLC Power Consumption	82 W
Discrete input logic	Sink or source
Discrete input voltage	24 V
Discrete input voltage type	DC
Voltage state 1 guaranteed	$\geq 15$ V for DC
Voltage state 0 guaranteed	$\leq 5$ V for DC
Discrete input current	7.5 mA for input

Disclaimer: This documentation is not intended as a substitute for and is not to be used for determining suitability or reliability of these products for specific user applications

	7.5 mA for fast input
Input impedance	2.81 kOhm for input
Response time	<= 1 µs turn-on, I0...I3 terminal(s) for fast input <= 1 µs turn-off, I0...I3 terminal(s) for fast input <= 1 µs turn-on, Q0...Q3 terminal(s) for fast output <= 1 µs turn-off, Q0...Q3 terminal(s) for fast output
Configurable filtering time	0.5 ms for fast input 0.01 ms for fast input 0.002 ms for fast input 1 ms for fast input 4 ms for fast input 0.1 ms for fast input 0.05 ms for fast input 0.005 ms for fast input 0.001 ms for fast input 12 ms for fast input
Discrete output logic	Source
Output voltage limits	30 V DC
Maximum current per output common	0.5 A with Q0...Q3 for fast output
Maximum output frequency	300 kHz
Accuracy	+/- 0.1 % at 0.02...0.1 kHz for fast output +/- 1 % at 0.1...1 kHz for fast output
Maximum leakage current	10 µA for output
Maximum tungsten load	<1.5 W
Protection type	Short-circuit and overload protection with automatic reset Reverse polarity protection Short-circuit protection
Reset time	200 ms automatic reset fast output
Memory capacity	32 MB for program RAM 32 MB for OS/website RAM 192 MB for system memory RAM
Data backed up	1 GB built-in flash memory for backup of user programs
Data storage equipment	<= 32 GB SDHC card (optional)
Backup time	1000 h at 25 °C
Execution time for 1 KInstruction	0.005 ms
Application structure	8 event tasks 4 cyclic master tasks 3 cyclic master tasks + 1 freewheeling task 8 external event tasks
Realtime clock	With
Clock drift	<= 10 s/month <= 10 s/month at 25 °C
Positioning functions	Libraries axes coordinated function
Integrated connection type	USB type mini B EtherNet port1 Ethernet 1 with RJ45 connector EtherNet port2 / switch Ethernet 2 with 2 RJ45 connector Serial link with RJ45 connector
Transmission rate	115 kbit/s for RS485 115 kbit/s for bus length of 15 m for RS485 115 kbit/s for bus length of 3 m for RS232 480 Mbit/s for bus length of 3 m for USB 10/100 Mbit/s for Ethernet1 115 kbit/s for RS232 1 Gbit/s for Ethernet2 480 Mbit/s for USB 10/100 Mbit/s 1 Gbit/s
Communication service	Ethernet/IP adapter DHCP client IEC VAR ACCESS Modbus TCP client Modbus TCP server SNMP client/server FTP client/server SQL client

Send and receive email from the controller based on TCP/UDP library  
 Web server  
 OPC UA server  
 DNS client  
 Web visu  
 Ethernet RSTP  
 MQTT

Local signalling	1 LED (green/red)PWR: 1 LED (green/red)RUN: 1 LED (green/red)ERROR (fault): 1 LED (green/red)stop forced: 1 LED (green/red)I/O error (I/O): 1 LED (green/orange)Sd card activity: 1 LED (green/orange)SL activity: 1 LED (green/red)ETH1 state: 1 LED (green/red)ETH2 state: 1 LED (green/red)EIP MS: 1 LED (green/red)EIP NS:
Electrical connection	removable spring terminal block removable spring terminal blockfor connecting the 24 V DC power supply
Maximum cable distance between devices	Shielded cable: <3 m for fast input Shielded cable: <3 m for fast output Unshielded cable: <50 m for input Unshielded cable: <50 m for output
Insulation	Between fast input and internal logic at 550 V AC Non-insulated between inputs Between output and internal logic at 500 V AC Between fast output and internal logic at 500 V AC Non-insulated between outputs Between input and output at 500 V AC Between supply and internal logic at 500 V AC Non-insulated between supply and ground
Surge withstand	1 kV power lines (DC) common mode conforming to EN/IEC 61000-4-5 1 kV shielded cable common mode conforming to EN/IEC 61000-4-5 0.5 kV relay output differential mode conforming to EN/IEC 61000-4-5 1 kV input common mode conforming to EN/IEC 61000-4-5 1 kV transistor output common mode conforming to EN/IEC 61000-4-5
Maximum number of connections	64 Ethernet/IP device 64 Modbus TCP device 96
Mounting support	Top hat type TH35-15 rail conforming to IEC 60715 Top hat type TH35-7.5 rail conforming to IEC 60715 plate or panel with fixing kit
Height	100 mm
Depth	90 mm
Width	125 mm
Net weight	0.655 kg

## Environment

Standards	UL 61010-1 UL 61010-2-201 CSA C22.2 No 61010-1 CSA C22.2 No 61010-2-201 CSA C22.2 No 213 ANSI/ISA 12-12-01 EN 61131-2
Product certifications	CE CULus RCM EAC Achilles
Resistance to electrostatic discharge	4 kV on contact conforming to EN/IEC 61000-4-2 8 kV on air conforming to EN/IEC 61000-4-2
Resistance to electromagnetic fields	10 V/m 80 MHz...1 GHz conforming to EN/IEC 61000-4-3 3 V/m 1.4 GHz...2 GHz conforming to EN/IEC 61000-4-3 1 V/m 2 GHz...3 GHz conforming to EN/IEC 61000-4-3
Resistance to fast transients	2 kV (power lines) conforming to EN/IEC 61000-4-4 1 kV (Ethernet line) conforming to EN/IEC 61000-4-4

	1 kV (serial link) conforming to EN/IEC 61000-4-4 1 kV (input) conforming to EN/IEC 61000-4-4 1 kV (transistor output) conforming to EN/IEC 61000-4-4
Resistance to conducted disturbances	10 V 0.15...80 MHz conforming to EN/IEC 61000-4-4 3 V 0.1...80 MHz 10 V spot frequency (2, 3, 4, 6.2, 8.2, 12.6, 16.5, 18.8, 22, 25 MHz)
Electromagnetic emission	Conducted emissions - test level: 120...69 dB $\mu$ V/m QP ( power lines) at 10...150 kHz conforming to EN/IEC 55011 Conducted emissions - test level: 63 dB $\mu$ V/m QP ( power lines) at 1.5...30 MHz conforming to EN/IEC 55011 Radiated emissions - test level: 40 dB $\mu$ V/m at 30...230 kHz conforming to EN/IEC 55011 Conducted emissions - test level: 79...63 dB $\mu$ V/m QP ( power lines) at 150...1500 kHz conforming to EN/IEC 55011 Radiated emissions at 230...1000 MHz conforming to EN/IEC 55011
Immunity to microbreaks	0.01 ms
Ambient air temperature for operation	-20...60 °C (horizontal installation) -20...50 °C (vertical installation) -20...45 °C (flat mounting)
Ambient air temperature for storage	-40...85 °C
Relative humidity	10...95 %, without condensation (in operation) 10...95 %, without condensation (in storage)
IP degree of protection	IP20
Pollution degree	2
Operating altitude	0...2000 m
Storage altitude	0...3000 m
Vibration resistance	3.5 mm at 2...8.4 Hz on symmetrical rail 1 gn at 8.4...200 Hz on symmetrical rail 3.5 mm at 2...8.4 Hz on panel mounting 1 gn at 8.4...200 Hz on panel mounting
Shock resistance	15 gn for 11 ms

## Packing Units

Package 1 Weight	0.600 kg
Package 1 Height	1.000 dm
Package 1 width	0.900 dm
Package 1 Length	1.250 dm

## Offer Sustainability

Sustainable offer status	Green Premium product
EU RoHS Directive	Pro-active compliance (Product out of EU RoHS legal scope) <a href="#">EU RoHS Declaration</a>
Mercury free	Yes
RoHS exemption information	<a href="#">Yes</a>
China RoHS Regulation	<a href="#">China RoHS declaration</a>
Environmental Disclosure	<a href="#">Product Environmental Profile</a>
Circularity Profile	<a href="#">End of Life Information</a>
WEEE	The product must be disposed on European Union markets following specific waste collection and never end up in rubbish bins
PVC free	Yes

Side and Front Views

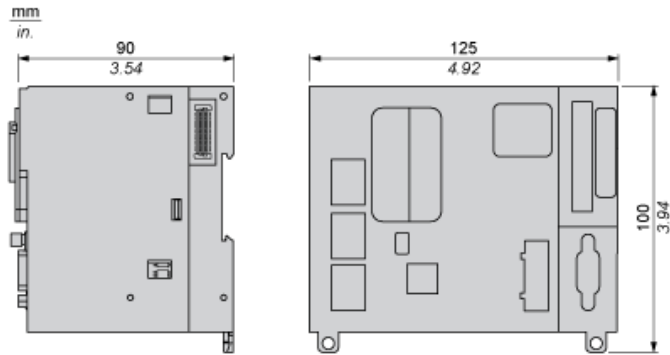

Correct Mounting Position

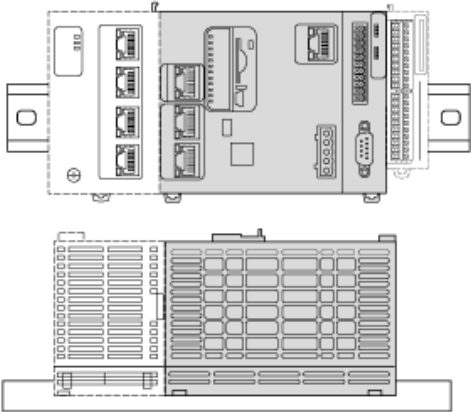

---

Acceptable Mounting Position

---

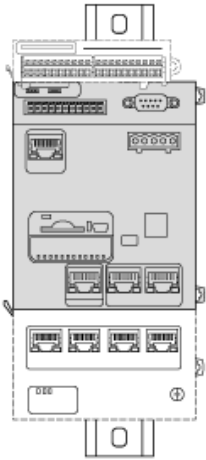

Incorrect Mounting Positions

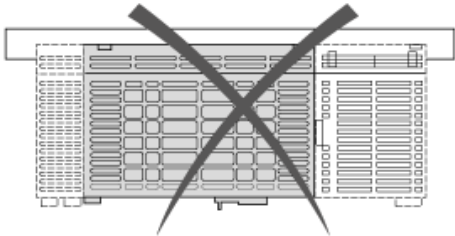
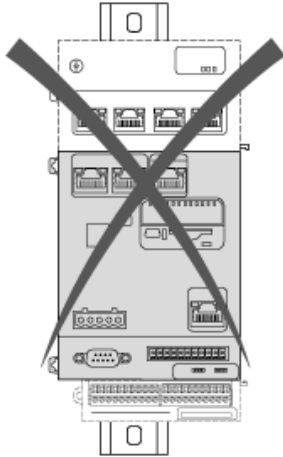
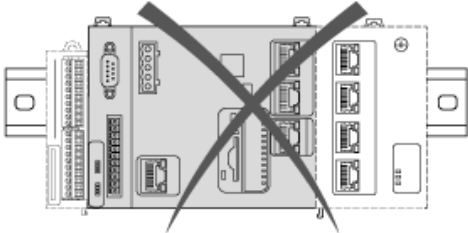

Minimum Clearances

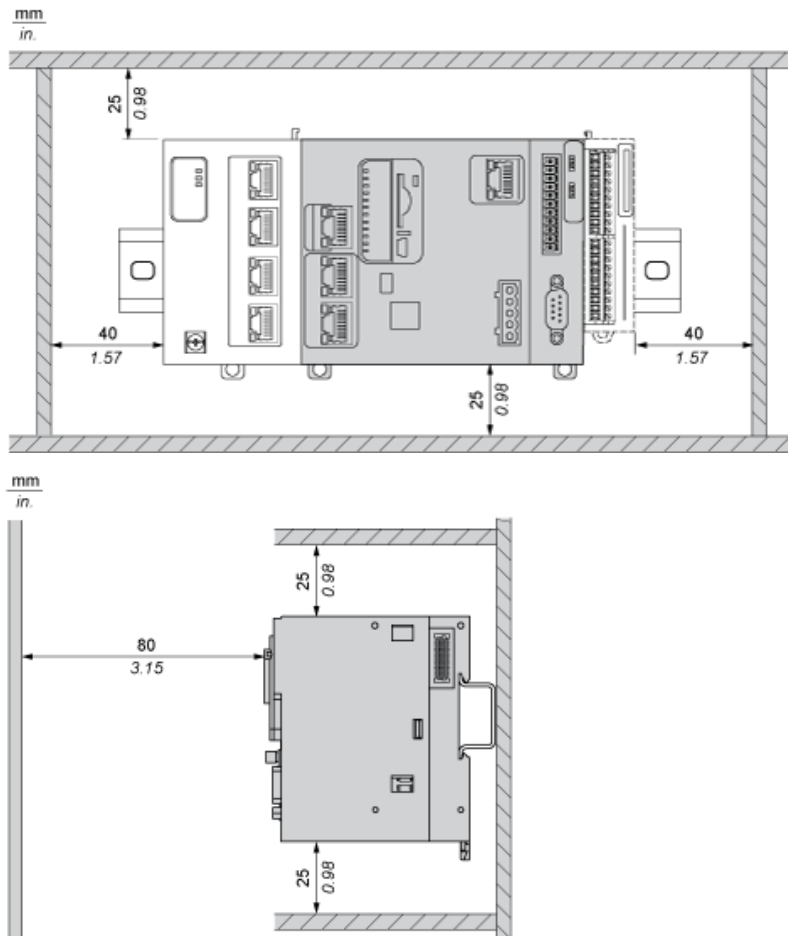

Encoder RS422 / 24 VDC

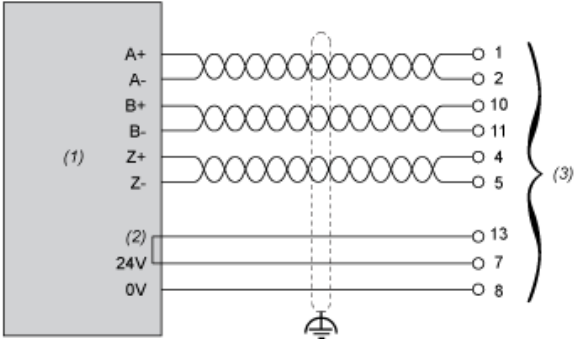

- (1) Encoder
- (2) Return Option
- (3) Encoder Sub-D

Encoder RS422 / 5 VDC or Push Pull

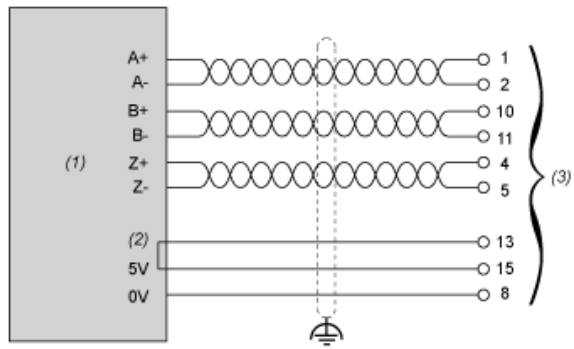

- (1) Encoder
- (2) Return Option
- (3) Encoder Sub-D

Encoder SSI

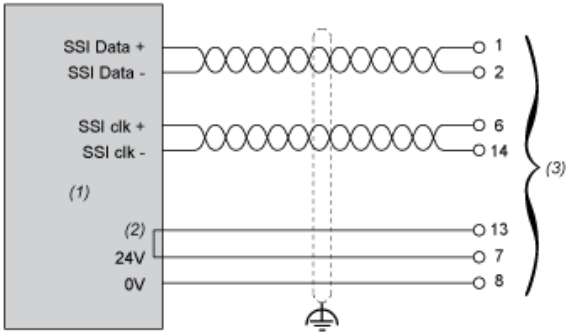

- (1) Encoder
- (2) Return Option
- (3) Encoder Sub-D