



### Main

Range of product	Modicon M241
Product or component type	Logic controller
[Us] rated supply voltage	24 V DC
Discrete input number	14, discrete input 8 fast input conforming to IEC 61131-2 Type 1
Discrete output type	Transistor
Discrete output number	10 transistor 4 fast output
Discrete output voltage	24 V DC for transistor output
Discrete output current	0.5 A for transistor output (Q0...Q9) 0.1 A for fast output (PTO mode) (Q0...Q3)

### Complementary

Discrete I/O number	24
Maximum number of I/O expansion module	7 (local I/O-Architecture) 14 (remote I/O-Architecture)
Supply voltage limits	20.4...28.8 V
Inrush current	50 A
Power consumption in W	32.6...40.4 W (with max number of I/O expansion module)
Discrete input logic	Sink or source
Discrete input voltage	24 V
Discrete input voltage type	DC
Voltage state 1 guaranteed	$\geq 15$ V for input
Voltage state 0 guaranteed	$\leq 5$ V for input
Discrete input current	5 MA for input 10.7 mA for fast input
Input impedance	4.7 kOhm for input 2.81 kOhm for fast input
Response time	50 $\mu$ s turn-on, I0...I13 terminal(s) for input 50 $\mu$ s turn-off, I0...I13 terminal(s) for input $\leq 2$ $\mu$ s turn-on, I0...I7 terminal(s) for fast input $\leq 2$ $\mu$ s turn-off, I0...I7 terminal(s) for fast input $\leq 34$ $\mu$ s turn-on, Q0...Q9 terminal(s) for output $\leq 250$ $\mu$ s turn-off, Q0...Q9 terminal(s) for output $\leq 2$ $\mu$ s turn-on, Q0...Q3 terminal(s) for fast output $\leq 2$ $\mu$ s turn-off, Q0...Q3 terminal(s) for fast output
Configurable filtering time	1 $\mu$ s for fast input 12 ms for fast input 0 ms for input 1 ms for input 4 ms for input 12 ms for input
Discrete output logic	Positive logic (source)
Output voltage limits	30 V DC
Maximum current per output common	2 A with Q0...Q3 for fast output 2 A with Q4...Q7 for output 1 A with Q8...Q9 for output
Maximum output frequency	20 KHz for fast output (PWM mode) 100 KHz for fast output (PLS mode) 1 kHz for output
Accuracy	+/- 0.1 % at 0.02...0.1 kHz for fast output +/- 1 % at 0.1...1 kHz for fast output

The information provided in this documentation contains general descriptions and/or technical characteristics of the performance of the products contained herein. This documentation is not intended as a substitute for and is not to be used for determining suitability or reliability of these products for specific user applications. It is the duty of any such user or integrator to perform the appropriate and complete risk analysis, evaluation and testing of the products with respect to the relevant specific application or use thereof. Neither Schneider Electric Industries SAS nor any of its affiliates or subsidiaries shall be responsible or liable for misuse of the information contained herein.

Maximum leakage current	5 µA for output
Maximum voltage drop	<1 V
Maximum tungsten load	<2.4 W
Protection type	Short-circuit protection Short-circuit and overload protection with automatic reset Reverse polarity protection for fast output
Reset time	10 Ms automatic reset output 12 s automatic reset fast output
Memory capacity	8 MB for program 64 MB for system memory RAM
Data backed up	128 MB built-in flash memory for backup of user programs
Data storage equipment	<= 16 GB SD card (optional)
Battery type	BR2032 lithium non-rechargeable, battery life: 4 year(s)
Backup time	2 years at 25 °C
Execution time for 1 KInstruction	0.3 Ms for event and periodic task 0.7 ms for other instruction
Application structure	8 external event tasks 4 cyclic master tasks 3 cyclic master tasks + 1 freewheeling task 8 event tasks
Realtime clock	With
Clock drift	<= 60 s/month at 25 °C
Positioning functions	PTO function 4 channel(s) (positioning frequency: 100 kHz) PTO function 4 channel(s) for transistor output (positioning frequency: 1 kHz)
Counting input number	4 fast input (HSC mode) at 200 kHz 14 standard input at 1 kHz
Control signal type	A/B at 100 kHz for fast input (HSC mode) Pulse/Direction at 200 kHz for fast input (HSC mode) Single phase at 200 kHz for fast input (HSC mode)
Integrated connection type	Non isolated serial link serial 1 with RJ45 connector and RS232/RS485 interface Non isolated serial link serial 2 with removable screw terminal block connector and RS485 interface USB port with mini B USB 2.0 connector Ethernet with RJ45 connector CANopen J1939 with male SUB-D 9 connector
Supply	(serial 1)serial link supply: 5 V, <200 mA
Transmission rate	1.2...115.2 kbit/s (115.2 kbit/s by default) for bus length of 15 m for RS485 1.2...115.2 kbit/s (115.2 kbit/s by default) for bus length of 3 m for RS232 480 Mbit/s for bus length of 3 m for USB 10/100 Mbit/s for Ethernet 1000 kbit/s for bus length of 20 m for CANopen 800 kbit/s for bus length of 40 m for CANopen 500 kbit/s for bus length of 100 m for CANopen 250 kbit/s for bus length of 250 m for CANopen 125 kbit/s for bus length of 500 m for CANopen 50 kbit/s for bus length of 1000 m for CANopen 20 kbit/s for bus length of 2500 m for CANopen
Communication port protocol	Non isolated serial link: Modbus master/slave
Port Ethernet	10BASE-T/100BASE-TX - 1 port(s) copper cable
Ethernet services	SNMP client/server Modbus TCP slave device Modbus TCP server Modbus TCP client IEC VAR ACCESS FTP client/server SQL client DHCP client Ethernet/IP adapter Send and receive email from the controller based on TCP/UDP library Web server (WebVisu & XWeb system) OPC UA server DNS client

Local signalling	<ul style="list-style-type: none"> <li>1 LED (green) for PWR</li> <li>1 LED (green) for RUN</li> <li>1 LED (red) for module error (ERR)</li> <li>1 LED (red) for I/O error (I/O)</li> <li>1 LED (green) for SD card access (SD)</li> <li>1 LED (red) for BAT</li> <li>1 LED (green) for SL1</li> <li>1 LED (green) for SL2</li> <li>1 LED (red) for bus fault on TM4 (TM4)</li> <li>1 LED per channel (green) for I/O state</li> <li>1 LED (green) for Ethernet port activity</li> <li>1 LED (green) for CANopen run</li> <li>1 LED (green) for CANopen error</li> </ul>
Electrical connection	<ul style="list-style-type: none"> <li>Removable screw terminal blockfor inputs and outputs (pitch 5.08 mm)</li> <li>Removable screw terminal blockfor connecting the 24 V DC power supply (pitch 5.08 mm)</li> </ul>
Maximum cable distance between devices	<ul style="list-style-type: none"> <li>Unshielded cable: &lt;50 m for input</li> <li>Shielded cable: &lt;10 m for fast input</li> <li>Unshielded cable: &lt;50 m for output</li> <li>Shielded cable: &lt;3 m for fast output</li> </ul>
Insulation	<ul style="list-style-type: none"> <li>Between supply and internal logic at 500 V AC</li> <li>Non-insulated between supply and ground</li> <li>Between input and internal logic at 500 V AC</li> <li>Non-insulated between inputs</li> <li>Between fast input and internal logic at 500 V AC</li> <li>Between output and internal logic at 500 V AC</li> <li>Non-insulated between outputs</li> <li>Between fast output and internal logic at 500 V AC</li> </ul>
Marking	CE
Surge withstand	<ul style="list-style-type: none"> <li>1 KV power lines (DC) common mode conforming to EN/IEC 61000-4-5</li> <li>1 KV shielded cable common mode conforming to EN/IEC 61000-4-5</li> <li>0.5 KV power lines (DC) differential mode conforming to EN/IEC 61000-4-5</li> <li>1 KV relay output differential mode conforming to EN/IEC 61000-4-5</li> <li>1 KV input common mode conforming to EN/IEC 61000-4-5</li> <li>1 kV transistor output common mode conforming to EN/IEC 61000-4-5</li> </ul>
Web services	Web server
Maximum number of connections	<ul style="list-style-type: none"> <li>16 Ethernet/IP device</li> <li>8 Modbus server</li> </ul>
CANopen feature profile	<ul style="list-style-type: none"> <li>DS 301 V4.02</li> <li>DR 303-1</li> </ul>
Number of slave	63 CANopen:
Mounting support	<ul style="list-style-type: none"> <li>Top hat type TH35-15 rail conforming to IEC 60715</li> <li>Top hat type TH35-7.5 rail conforming to IEC 60715</li> <li>Plate or panel with fixing kit</li> </ul>
Height	90 mm
Depth	95 mm
Width	150 mm
Net weight	0.53 kg

## Environment

Standards	<ul style="list-style-type: none"> <li>ANSI/ISA 12-12-01</li> <li>CSA C22.2 No 142</li> <li>CSA C22.2 No 213</li> <li>EN/IEC 61131-2:2007</li> <li>Marine specification (LR, ABS, DNV, GL)</li> <li>UL 1604</li> <li>UL 508</li> </ul>
Product certifications	<ul style="list-style-type: none"> <li>IACS E10</li> <li>RCM</li> <li>CULus</li> <li>CSA</li> </ul>
Resistance to electrostatic discharge	<ul style="list-style-type: none"> <li>8 kV in air conforming to EN/IEC 61000-4-2</li> <li>4 kV on contact conforming to EN/IEC 61000-4-2</li> </ul>
Resistance to electromagnetic fields	<ul style="list-style-type: none"> <li>10 V/M 80 MHz...1 GHz conforming to EN/IEC 61000-4-3</li> <li>3 V/M 1.4 GHz...2 GHz conforming to EN/IEC 61000-4-3</li> <li>1 V/m 2 GHz...3 GHz conforming to EN/IEC 61000-4-3</li> </ul>
Resistance to fast transients	<ul style="list-style-type: none"> <li>2 KV (power lines) conforming to EN/IEC 61000-4-4</li> <li>1 KV (Ethernet line) conforming to EN/IEC 61000-4-4</li> <li>1 KV (serial link) conforming to EN/IEC 61000-4-4</li> <li>1 KV (input) conforming to EN/IEC 61000-4-4</li> <li>1 kV (transistor output) conforming to EN/IEC 61000-4-4</li> </ul>

Resistance to conducted disturbances	10 V 0.15...80 MHz conforming to EN/IEC 61000-4-6 3 V 0.1...80 MHz conforming to Marine specification (LR, ABS, DNV, GL) 10 V spot frequency (2, 3, 4, 6.2, 8.2, 12.6, 16.5, 18.8, 22, 25 MHz) conforming to Marine specification (LR, ABS, DNV, GL)
Electromagnetic emission	Conducted emissions - test level: 120...69 dB $\mu$ V/m QP ( power lines) at 10...150 kHz conforming to EN/IEC 55011 Conducted emissions - test level: 63 dB $\mu$ V/m QP ( power lines) at 1.5...30 MHz conforming to EN/IEC 55011 Radiated emissions - test level: 40 dB $\mu$ V/m QP class A at 30...230 MHz conforming to EN/IEC 55011 Conducted emissions - test level: 79...63 dB $\mu$ V/m QP ( power lines) at 150...1500 kHz conforming to EN/IEC 55011 Radiated emissions - test level: 47 dB $\mu$ V/m QP class A at 230...1000 MHz conforming to EN/IEC 55011
Immunity to microbreaks	10 ms
Ambient air temperature for operation	-10...50 °C (vertical installation) -10...55 °C (horizontal installation)
Ambient air temperature for storage	-25...70 °C
Relative humidity	10...95 %, without condensation (in operation) 10...95 %, without condensation (in storage)
IP degree of protection	IP20 with protective cover in place
Pollution degree	2
Operating altitude	0...2000 m
Storage altitude	0...3000 m
Vibration resistance	3.5 mm at 5...8.4 Hz on symmetrical rail 3 gn at 8.4...150 Hz on symmetrical rail 3.5 mm at 5...8.4 Hz on panel mounting 3 gn at 8.4...150 Hz on panel mounting
Shock resistance	15 gn for 11 ms

## Packing Units

Unit Type of Package 1	PCE
Number of Units in Package 1	1
Package 1 Height	11.3 cm
Package 1 Width	13.115 cm
Package 1 Length	18.729 cm
Package 1 Weight	661.0 g
Unit Type of Package 2	S03
Number of Units in Package 2	8
Package 2 Height	30 cm
Package 2 Width	30 cm
Package 2 Length	40 cm
Package 2 Weight	6.16 kg
Unit Type of Package 3	P06
Number of Units in Package 3	64
Package 3 Height	75.0 cm
Package 3 Width	40.0 cm
Package 3 Length	80.0 cm
Package 3 Weight	59 kg

## Offer Sustainability

Sustainable offer status	Green Premium product
REACH Regulation	 <a href="#">REACH Declaration</a>
EU RoHS Directive	Pro-active compliance (Product out of EU RoHS legal scope)  <a href="#">EU RoHS Declaration</a>
Mercury free	Yes
China RoHS Regulation	 <a href="#">China RoHS Declaration</a>
RoHS exemption information	 Yes
Environmental Disclosure	 <a href="#">Product Environmental Profile</a>

---

Circularity Profile	<a href="#">End Of Life Information</a>
WEEE	The product must be disposed on European Union markets following specific waste collection and never end up in rubbish bins
PVC free	Yes

---

### Contractual warranty

---

Warranty	18 Monate
----------	-----------

---

Dimensions

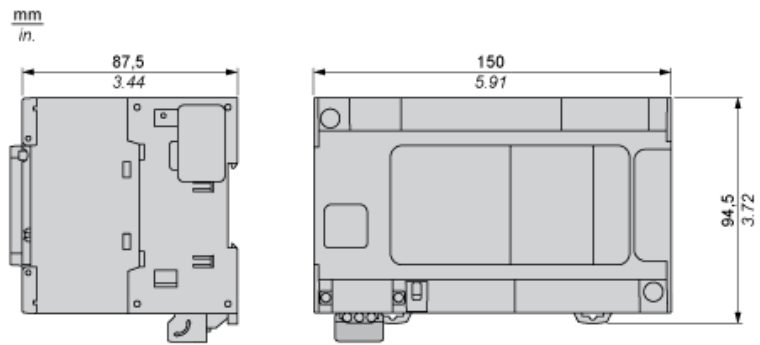

Clearance

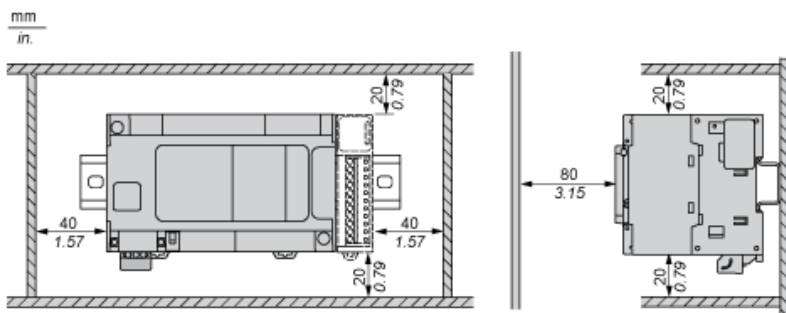

Mounting Position

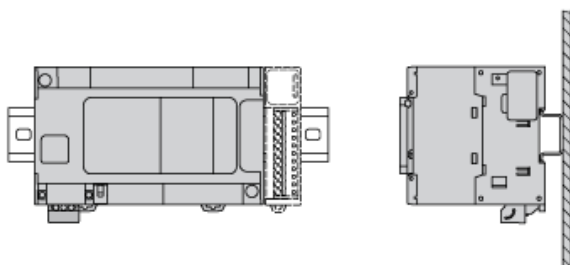

Acceptable Mounting

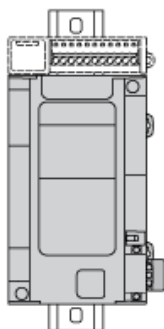

NOTE: Expansion modules must be mounted above the logic controller.

Incorrect Mounting

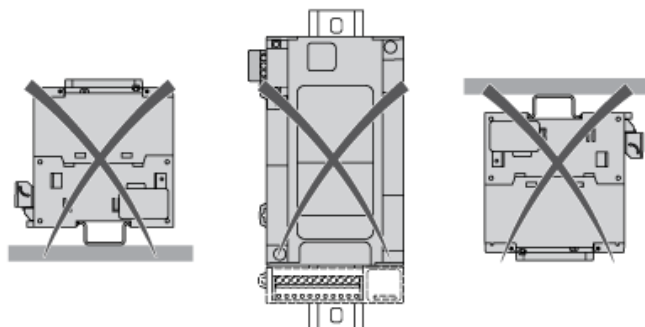

Direct Mounting On a Panel Surface

## Mounting Hole Layout

mm  
in.

M4 x 6/8 mm  
0.24/0.31 in.

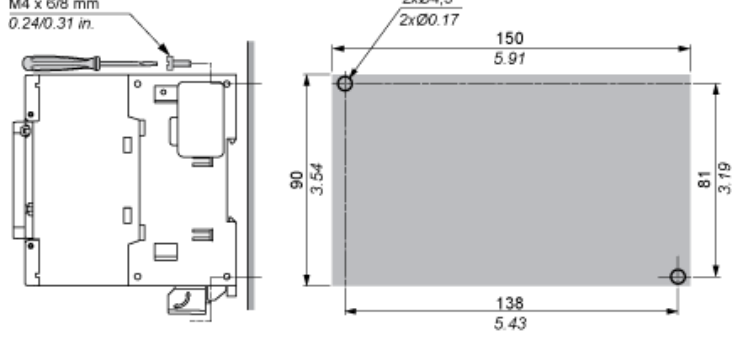

Digital Inputs

Wiring Diagram

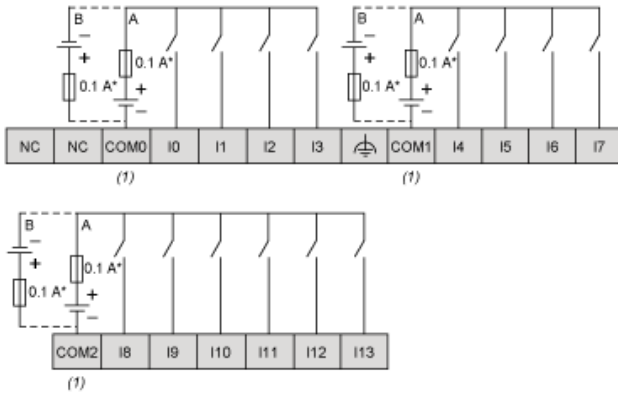

- (\*) : Type T fuse
- (1) : The COM0, COM1 and COM2 terminals are not connected internally
- (A) : Sink wiring (positive logic)
- (B) : Source wiring (negative logic)

Fast Input Wiring (I0...I7)

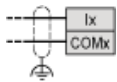

Fast Transistor Outputs

Wiring Diagram

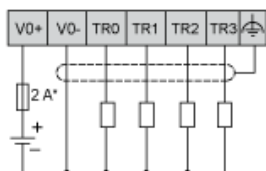

- (\*) : 2 A fast-blow fuse

Transistor Outputs

Wiring Diagram

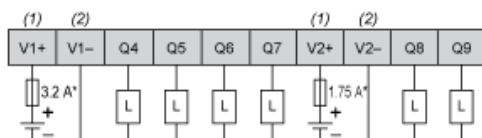

- (\*) : Type T fuse
- (1) : The V1+ and V2+ terminals are not connected internally.
- (2) : The V1- and V2- terminals are not connected internally.

USB Mini-B Connection

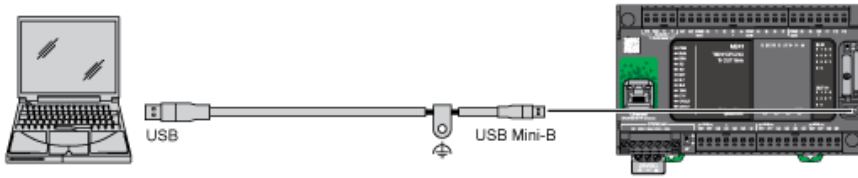

## Ethernet Connection to a PC

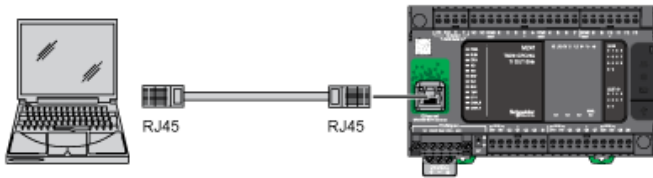

## CANopen Connection

### Wiring Diagram

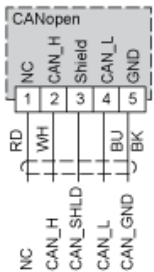

Pin	Signal	Description	Marking	Color of Cable
1	Not used	Reserved	NC	red
2	CAN_H	CAN_H bus line (dominant high)	CAN_H	white
3	CAN_SHLD	Optional CAN shield	Shield	-
4	CAN_L	CAN_L bus line (dominant low)	CAN_L	blue
5	CAN_GND	CAN Ground	GND	black